



Profit from the Eagle Advantage®

Specification Sheet

Short Form Specifications

Eagle Spec-Master® Enclosed Base Worktable, model _____ . Top is 14/304 stainless steel, sides and back are heavy gauge stainless steel. (Open Front, Stainless steel Sliding Doors, or Stainless steel Hinged Door) models with 1½" rolled edge on front and rear, sides turned down. Constructed with uni-lok® patented gusset system, with the gussets recessed into the hat channels to reduce lateral movement. 1½" O.D. stainless steel tubular legs with adjustable bullet feet.



enclosed worktable with sliding doors

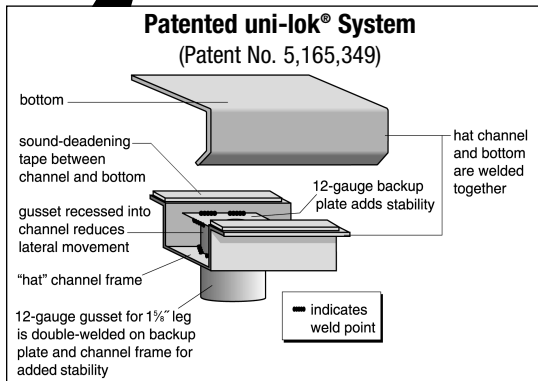

Item No.: _____
 Project No.: _____
 S.I.S. No.: _____

Spec-Master® Enclosed Worktables with Flat Top

MODELS:

- | | | |
|------------------------------------|------------------------------------|-------------------------------------|
| <input type="checkbox"/> OB2436SE | <input type="checkbox"/> CB2436SE | <input type="checkbox"/> CBH2436SE |
| <input type="checkbox"/> OB2448SE | <input type="checkbox"/> CB2448SE | <input type="checkbox"/> CBH2448SE |
| <input type="checkbox"/> OB2460SE | <input type="checkbox"/> CB2460SE | <input type="checkbox"/> CBH2460SE |
| <input type="checkbox"/> OB2472SE | <input type="checkbox"/> CB2472SE | <input type="checkbox"/> CBH2472SE |
| <input type="checkbox"/> OB2484SE | <input type="checkbox"/> CB2484SE | <input type="checkbox"/> CBH2484SE |
| <input type="checkbox"/> OB2496SE | <input type="checkbox"/> CB2496SE | <input type="checkbox"/> CBH2496SE |
| <input type="checkbox"/> OB24120SE | <input type="checkbox"/> CB24120SE | <input type="checkbox"/> CBH24120SE |
| <input type="checkbox"/> OB3036SE | <input type="checkbox"/> CB3036SE | <input type="checkbox"/> CBH3036SE |
| <input type="checkbox"/> OB3048SE | <input type="checkbox"/> CB3048SE | <input type="checkbox"/> CBH3048SE |
| <input type="checkbox"/> OB3060SE | <input type="checkbox"/> CB3060SE | <input type="checkbox"/> CBH3060SE |
| <input type="checkbox"/> OB3072SE | <input type="checkbox"/> CB3072SE | <input type="checkbox"/> CBH3072SE |
| <input type="checkbox"/> OB3084SE | <input type="checkbox"/> CB3084SE | <input type="checkbox"/> CBH3084SE |
| <input type="checkbox"/> OB3096SE | <input type="checkbox"/> CB3096SE | <input type="checkbox"/> CBH3096SE |
| <input type="checkbox"/> OB30120SE | <input type="checkbox"/> CB30120SE | <input type="checkbox"/> CBH30120SE |

Design and Construction Features

- All-welded design.
- Available with open front, sliding doors, or hinged doors.
- Doors are 20 gauge type 430 stainless steel.
- Top mechanically polished to satin finish.
- Sound-deadened between top and frame.
- 1½" (42mm)-diameter type 304 stainless legs.
- 1" (25mm) stainless steel adjustable bullet feet.
- 1½" (38mm) sanitary rolled rim on front and back with square edge on ends for flush fit.
- Optional fixed center shelf available. To order, add suffix "-CS" to model number. Example: OB2436SE-CS

Options / Accessories

- | | |
|--|--|
| <input type="checkbox"/> Lock (for units with doors) | <input type="checkbox"/> Center shelf |
| <input type="checkbox"/> Casters* | <input type="checkbox"/> Sound deadening |
| <input type="checkbox"/> Overshelf | |

* To order table with 4" (102mm)-diameter casters, add suffix "-CA" (ex: OB3048SE-CA). To order table with 5" (127mm)-diameter casters, add suffix "-CAH" (ex: CB3048SE-CAH).

EAGLE GROUP

100 Industrial Boulevard, Clayton, DE 19938-8903 USA
 Phone: 302-653-3000 • 800-441-8440 • Fax: 302-653-2065
 www.eaglegrp.com
 www.eaglehmc.com

For custom configuration or fabrication needs, contact our SpecFAB® Division.
 Phone: 302-653-3000 • Fax: 302-653-2065 • e-mail: quotes@eaglegrp.com



EG10.30 Rev. 11/23

Spec sheets available for viewing, printing or downloading from our online literature library at our websites



Item No.: _____
 Project No.: _____
 S.I.S. No.: _____

Spec-Master® Enclosed Worktables with Open Front

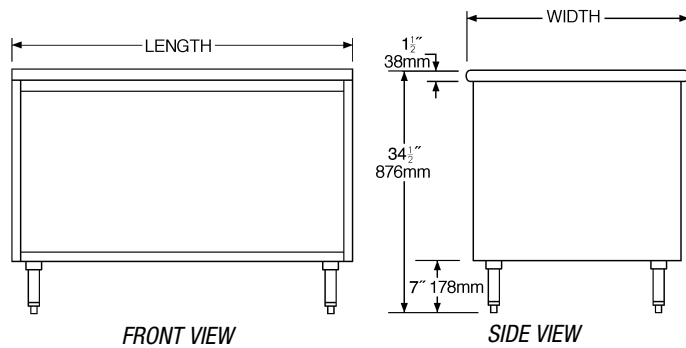

| model # | width | | length | | weight | | no. of legs |
|-----------|-------|-----|--------|------|--------|-------|-------------|
| | in. | mm | in. | mm | lbs. | kg | |
| OB2436SE | 24" | 610 | 36" | 914 | 179 | 81.2 | 4 |
| OB2448SE | 24" | 610 | 48" | 1219 | 238 | 108.0 | 4 |
| OB2460SE | 24" | 610 | 60" | 1524 | 298 | 135.2 | 4 |
| OB2472SE | 24" | 610 | 72" | 1829 | 357 | 161.9 | 4 |
| OB2484SE | 24" | 610 | 84" | 2134 | 417 | 189.2 | 6 |
| OB2496SE | 24" | 610 | 96" | 2438 | 476 | 215.9 | 6 |
| OB24120SE | 24" | 610 | 120" | 3048 | 595 | 269.9 | 6 |
| OB3036SE | 30" | 762 | 36" | 914 | 186 | 84.4 | 4 |
| OB3048SE | 30" | 762 | 48" | 1219 | 248 | 112.5 | 4 |
| OB3060SE | 30" | 762 | 60" | 1524 | 309 | 140.2 | 4 |
| OB3072SE | 30" | 762 | 72" | 1829 | 371 | 168.3 | 4 |
| OB3084SE | 30" | 762 | 84" | 2134 | 431 | 195.5 | 6 |
| OB3096SE | 30" | 762 | 96" | 2438 | 494 | 224.1 | 6 |
| OB30120SE | 30" | 762 | 120" | 3048 | 616 | 279.4 | 6 |

Spec-Master® Enclosed Worktables with Sliding Doors

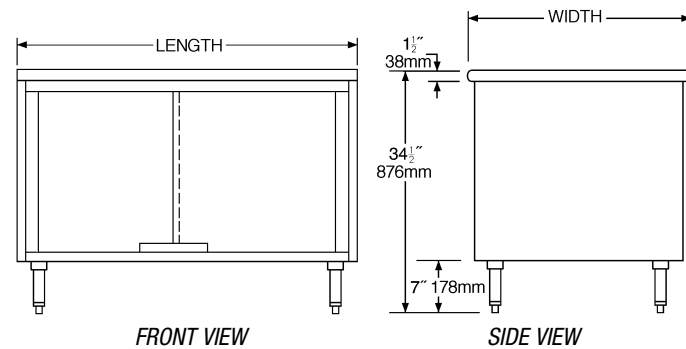

| model # | width | | length | | weight | | no. of legs |
|------------|-------|-----|--------|------|--------|-------|-------------|
| | in. | mm | in. | mm | lbs. | kg | |
| CB2436SE | 24" | 610 | 36" | 914 | 186 | 84.4 | 4 |
| CB2448SE | 24" | 610 | 48" | 1219 | 249 | 113.0 | 4 |
| CB2460SE | 24" | 610 | 60" | 1524 | 311 | 141.1 | 4 |
| CB2472SE | 24" | 610 | 72" | 1829 | 369 | 167.4 | 4 |
| CB2484SE* | 24" | 610 | 84" | 2134 | 435 | 197.3 | 6 |
| CB2496SE* | 24" | 610 | 96" | 2438 | 497 | 225.4 | 6 |
| CB24120SE* | 24" | 610 | 120" | 3048 | 621 | 281.7 | 6 |
| CB3036SE | 30" | 762 | 36" | 914 | 202 | 91.6 | 4 |
| CB3048SE | 30" | 762 | 48" | 1219 | 270 | 122.5 | 4 |
| CB3060SE | 30" | 762 | 60" | 1524 | 336 | 152.4 | 4 |
| CB3072SE | 30" | 762 | 72" | 1829 | 404 | 183.3 | 4 |
| CB3084SE* | 30" | 762 | 84" | 2134 | 471 | 213.7 | 6 |
| CB3096SE* | 30" | 762 | 96" | 2438 | 539 | 244.5 | 6 |
| CB30120SE* | 30" | 762 | 120" | 3048 | 672 | 304.8 | 6 |

* Note: Worktables 84" (2134mm) and longer have two sets of doors.

Spec-Master® Enclosed Worktables with Hinged Doors

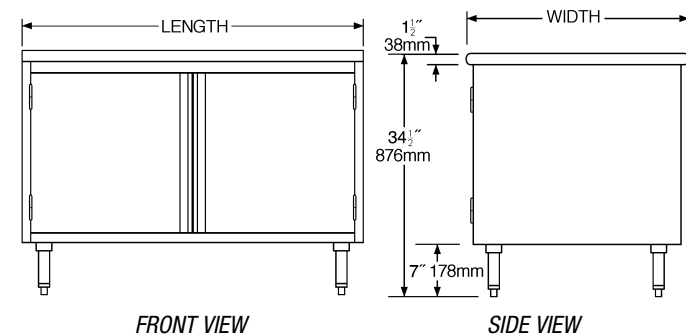

| model # | width | | length | | weight | | no. of legs |
|-------------|-------|-----|--------|------|--------|-------|-------------|
| | in. | mm | in. | mm | lbs. | kg | |
| CBH2436SE | 24" | 610 | 36" | 914 | 197 | 89.4 | 4 |
| CBH2448SE | 24" | 610 | 48" | 1219 | 263 | 119.3 | 4 |
| CBH2460SE | 24" | 610 | 60" | 1524 | 328 | 148.8 | 4 |
| CBH2472SE | 24" | 610 | 72" | 1829 | 394 | 178.7 | 4 |
| CBH2484SE* | 24" | 610 | 84" | 2134 | 459 | 208.2 | 6 |
| CBH2496SE* | 24" | 610 | 96" | 2438 | 525 | 238.1 | 6 |
| CBH24120SE* | 24" | 610 | 120" | 3048 | 656 | 297.6 | 6 |
| CBH3036SE | 30" | 762 | 36" | 914 | 207 | 93.9 | 4 |
| CBH3048SE | 30" | 762 | 48" | 1219 | 276 | 125.2 | 4 |
| CBH3060SE | 30" | 762 | 60" | 1524 | 344 | 156.0 | 4 |
| CBH3072SE | 30" | 762 | 72" | 1829 | 413 | 187.3 | 4 |
| CBH3084SE* | 30" | 762 | 84" | 2134 | 482 | 218.6 | 6 |
| CBH3096SE* | 30" | 762 | 96" | 2438 | 551 | 249.9 | 6 |
| CBH30120SE* | 30" | 762 | 120" | 3048 | 689 | 313.5 | 6 |

* Note: Worktables 84" (2134mm) and longer have two sets of doors.

EAGLE GROUP
 100 Industrial Boulevard, Clayton, DE 19938-8903 USA
 Phone: 302-653-3000 or 800-441-8440 • Fax: 302-653-2065
 www.eaglegrp.com • www.eaglehmc.com

Printed in U.S.A.
 ©2023 by Eagle Group

Rev. 11/23

Spec sheets available for viewing, printing or downloading from our online literature library at our websites

Although every attempt has been made to ensure the accuracy of the information provided, we cannot be held responsible for typographical or printing errors. Information and specifications are subject to change without notice. Please confirm at time of order.

