

Operating instructions Coffee machine



To avoid the risk of accidents or damage to the appliance it is **essential** to read these instructions before it is installed and used for the first time.

Caring for the environment

Disposing of the packaging material

The packaging material is used for handling and protects the appliance from transport damage. The packaging material used is selected from materials which are environmentally friendly for disposal and can generally be recycled.

Recycling the packaging material reduces the use of raw materials. Use material-specific collection points for valuable materials and take advantage of return options.

Disposing of your old appliance

Electrical and electronic appliances contain many valuable materials. They also contain certain materials, compounds and components which were essential for their correct functioning and safety. These could be hazardous to human health and to the environment if disposed of with household waste or if handled incorrectly. Please do not, therefore, dispose of your old appliance with household waste.



Instead, please make use of officially designated collection and disposal points to dispose of and recycle electrical and electronic appliances in your local community, with your dealer or with Miele, free of charge. By law, you are solely responsible for deleting any personal data from the old appliance prior to disposal. You are legally obliged to remove any old batteries which are not securely enclosed by the appliance and to remove any lamps without destroying them, where this is possible. These must be taken to a suitable collection point where they can be handed in free of charge. Please ensure that your old appliance poses no risk to children while being stored for disposal.

Caring for the environment	2
Warning and Safety instructions	7
Guide to the machine	17
Rear of machine	18
Milk flask and milk siphon	19
Unpacking and installing	20
Unpacking the coffee machine	20
Accessories supplied	20
Setting up and connecting the coffee machine	20
Operation	22
Touch display	22
Operation.....	22
Symbols in the display	24
Before using for the first time	26
Fit the descaling cartridge.....	26
Set the water hardness level	27
Set up the bean system	28
Bean system	30
Changing bean system settings (Type of beans).....	31
Renaming type of beans	31
Changing bean type allocation.....	31
Filling the water container	32
Switching on and off	33
Spout adjustment	34
Cup heating	35
Making coffee with and without milk	36
Making a coffee.....	36
Cancelling preparation	36
DoubleShot.....	36
Making two portions ☐	37
Coffee pot: making several cups of coffee one after the other.....	37
Making coffee with milk	39
Using a milk carton with the milk siphon	40
Making drinks with milk.....	41

Contents

Cancelling a drink.....	41
Tea	42
TeaTimer.....	42
Making tea.....	43
Cancelling tea preparation	43
Tea pot: making several cups of tea, one after the other	43
Dispensing hot water	45
Parameters	46
Quantity of coffee.....	46
Brewing temperature	46
Pre-brewing the ground coffee.....	46
Type of beans	47
Grinder setting.....	47
Portion size	48
Resetting drinks	49
Profiles	50
Creating a profile	50
Opening the Profiles menu and selecting a profile.....	50
Processing profiles	50
Profiles: creating and processing drinks	52
Profiles: making drinks	53
Expert mode	54
Settings	55
Opening the Settings menu.....	55
Changing and saving settings.....	55
Language.....	55
Time.....	55
Timer	55
Switch on at	56
Switch off at	56
Switch off after	56
Allocating days of the week	56
Eco mode	57
Lighting.....	57
Water hardness	57
Info (display information)	57

System lock 	58
Miele@home	58
Display brightness	58
Volume	58
Service	58
Evaporate	58
Demo mode	58
Factory default	59
Appliance settings	59
Network configuration	59
Networking	60
Setting up the network (Miele@home)	60
Setting up the network again	61
Remote control	61
MobileStart	62
RemoteUpdate	63
Cleaning and care	64
Overview of cleaning intervals	64
Cleaning by hand or in the dishwasher	65
Unsuitable cleaning agents	66
Clean the drip tray and waste container	67
Cleaning the drip tray cover	68
Cleaning the water container	69
Removing and cleaning the water container filter	69
Cleaning the central spout with integrated Cappuccinatore	70
Removing and cleaning the cup sensor	71
Cleaning the milk siphon	72
Cleaning the milk flask	72
Cleaning the milk pipework manually or using the maintenance programme	72
Cleaning the bean system	73
Ground coffee drawer cleaning	74
Vacuuming out the ground coffee chute	74
Cleaning the casing	75
Maintenance programmes	75
Rinsing the machine	76
Rinsing the milk pipework	76
Cleaning the milk pipework	77
Degreasing the brew unit and cleaning the interior	78
Descaling the machine	80
Automatic descaling	83
Please note before and during automatic descaling:	83

Contents

The Miele descaling cartridge	84
Fitting and removing a descaling cartridge	85
Set the start time for automatic descaling (Descaling timer)	86
Cancelling automatic descaling	86
Switching off automatic descaling	87
Problem solving guide	88
Messages in the display	88
Unusual performance of the coffee machine	91
Faults with automatic descaling	96
Unsatisfactory results	97
Service	99
Contact in the event of a fault	99
Warranty	99
Transporting the machine	100
Evaporate	100
Vacuuming out the ground coffee chute using the attachment and cleaning the interior	101
Packing the machine	101
Accessories	102
Saving energy	103
Electrical connection	104
Dimensions	105
Technical data	106
EU Conformity declaration	107
UK Conformity declaration	108

Warning and Safety instructions

This coffee machine complies with all the stipulated safety requirements. Inappropriate use can, however, lead to personal injury and material damage.

Read the operating instructions carefully before using the coffee machine. They contain important information on the installation, safety, use and maintenance of the appliance. This prevents both personal injury and damage to the coffee machine.

In accordance with standard IEC 60335-1, Miele expressly and strongly advises that you read and follow the instructions in the chapter on installing and connecting the coffee machine as well as the safety instructions and warnings.

Miele cannot be held liable for injury or damage caused by non-compliance with these instructions.

Keep these operating instructions in a safe place and pass them on to any future owner.

Warning and Safety instructions

Correct application

- ▶ This coffee machine is intended for home use.
- ▶ It must only be used as a domestic appliance to make espresso, cappuccino, latte macchiato, tea etc. Any other use is not permitted.
- ▶ This coffee machine is not intended for outdoor use.
- ▶ This coffee machine must not be used at altitudes above 2000 m.
- ▶ This coffee machine can only be used by people with reduced physical, sensory or mental capabilities, or lack of experience and knowledge, if they are supervised whilst using it, or have been shown how to use it in a safe way and recognise and understand the consequences of incorrect operation.

Safety with children

 Danger of burning and scalding on the dispensing spouts.

Children's skin is far more sensitive to high temperatures than that of adults.

Ensure children do not touch hot surfaces of the coffee machine or place parts of their body under the dispensing spouts.

- ▶ Install the coffee machine where it is out of the reach of children.
- ▶ Children under 8 years of age must be kept away from the coffee machine and the mains connection cable and plug/socket.
- ▶ Children aged 8 and older may only use the coffee machine without supervision if they have been shown how to use it in a safe manner.
Children aged 8 and older must be aware of the potential dangers caused by incorrect operation.
- ▶ Please supervise children in the vicinity of the coffee machine and do not allow them to play with it.
- ▶ Young children must not be allowed to clean the coffee machine at all. Cleaning may only be carried out by children 8 years of age or older under the supervision of an adult.
- ▶ Remember that coffee and espresso are not suitable drinks for children.
- ▶ Danger of suffocation! Whilst playing, children may become entangled in packaging material (such as plastic wrapping) or pull the packaging material over their head, presenting the risk of suffocation. Keep packaging material away from children.

Technical safety

- ▶ A damaged coffee machine is dangerous. Check it for any visible damage before setting it up. Never attempt to use a damaged coffee machine.

Warning and Safety instructions

- ▶ To avoid the risk of damage to the machine, make sure the connection data (voltage and frequency) on the data plate corresponds to the household supply, before connecting the machine to the mains supply. Consult a qualified electrician if in any doubt.
- ▶ The electrical safety of this coffee machine can only be guaranteed when correctly earthed. It is essential that this standard safety requirement is met. If in any doubt please have the electrical installation tested by a qualified electrician.
- ▶ Temporary or permanent operation on an autonomous power supply system or a power supply system that is not synchronised with the mains power supply (e.g. island networks, back-up systems) is possible. A prerequisite for operation is that the power supply system complies with the specifications of EN 50160 or an equivalent standard.

The function and operation of the protective measures provided in the domestic electrical installation and in this Miele product must also be maintained in isolated operation or in operation that is not synchronised with the mains power supply, or these measures must be replaced by equivalent measures in the installation. As described, for example, in the current version of BS OHSAS 18001–2 ISO 45001.
- ▶ Do not connect the machine to the mains electricity supply by a multi-socket adapter or an extension lead. These are a fire hazard and do not guarantee the required safety of the appliance.
- ▶ The coffee machine must not be used in a non-stationary location (e.g. on a ship).
- ▶ Unplug the machine from the power supply immediately if you notice any damage or smell scorching, for example.
- ▶ Ensure that the mains connection cable cannot be pinched or damaged by any sharp edges.

Warning and Safety instructions

- ▶ The mains connection cable should not hang down. Someone could trip over it with the risk of injury and damage the machine.
- ▶ Only use the coffee machine in rooms where the ambient temperature is between +16 °C and +38 °C.
- ▶ Do not place the coffee machine near a window in direct sunshine or right next to an appliance that gives off heat. These would subject the machine to ambient temperatures outside its permitted operating range.
- ▶ Position the coffee machine at a height of at least 850 mm from the floor.
- ▶ Danger of overheating. Please ensure that there is adequate ventilation around the coffee machine. Do not cover the coffee machine with tea towels etc. while it is in use.
- ▶ The coffee machine must not be installed in a niche. Heat and moisture can accumulate in a niche. This can result in damage to the appliance and/or furniture unit.
- ▶ Protect the coffee machine from water and water spray. Do not immerse the machine in water.
- ▶ Repairs and other work by unqualified persons to the machine and the connection cable could be dangerous. The manufacturer cannot be held liable for unauthorised work. Repairs may only be carried out by a Miele authorised service technician.
- ▶ While the machine is under warranty, repairs should only be undertaken by a Miele authorised service technician. Otherwise the warranty is invalidated.
- ▶ The coffee machine must be disconnected from the electricity supply during repair work.

Warning and Safety instructions

▶ Never open the outer casing of the machine. Tampering with electrical connections or components and mechanical parts is highly dangerous to the user and can cause operational faults or electric shock.

Correct use

 Danger of burning and scalding on the dispensing spouts. The liquids and steam dispensed are very hot.

Keep well away from the area underneath the spouts when hot liquids and steam are being dispensed.

Do not touch hot components.

Hot liquid or steam could spatter from the spouts. Ensure that the central spout is clean and fitted correctly.

Water in the drip tray can also be very hot. Take care when emptying it.

 Danger of injury to the eyes.

Never look directly at the lighting or use optical instruments to look at it.

► Please note the following regarding water:

- The water quality must conform to the requirements for drinking water in the country in which the coffee machine is being used.
- Only use cold, fresh tap water to fill the water container. Hot or warm water or other liquids can damage the coffee machine.
- Change the water every day to prevent a build-up of bacteria.
- Do not use carbonated water.

► Only fill the bean container with roasted espresso/coffee beans. Do not fill the bean container with coffee beans which have been treated with additives or with ground coffee.

► Do not fill the bean containers with any type of liquid.

► Do not use green (unroasted) coffee beans or mixtures of coffee beans which contain green coffee beans. Green coffee beans are very hard and still contain residual moisture. These can damage the coffee machine grinder as soon as grinding begins.

Warning and Safety instructions

- ▶ Do not use coffee beans which have been treated with caramel, sugar or other substances including sugary liquids. Sugar will damage the coffee machine.
- ▶ Only fill the coffee chute with ground coffee beans.
- ▶ Do not use any caramelised ready ground coffee. The sugar in the coffee will stick to and block the brew unit of the coffee machine. The cleaning tablets for degreasing the brew unit will not remove this type of deposit.
- ▶ If decaffeinated coffee beans are used after dispensing a drink with caffeinated beans, there may still be residues from the caffeinated beans in the grinder or brew chamber. Discard the first coffee drink when using decaffeinated coffee.
- ▶ Only use milk without additives. Additives in milk usually contain sugar and this will stick to the milk pipework.
- ▶ If using dairy milk make sure that it has been pasteurised.
- ▶ When making tea, please follow the instructions on the packaging.
- ▶ Do not place flaming alcohol mixtures underneath the central spout. The flames could ignite plastic components and cause them to melt.
- ▶ Do not use naked flames, e.g. a candle, on or near the coffee machine. The coffee machine could catch fire with the risk of the fire spreading.
- ▶ The machine must not be used for cleaning objects.

Accessories and spare parts

- ▶ Miele can only guarantee the safety of the machine when original Miele spare parts are used. Faulty components must only be replaced by genuine Miele original spare parts.
- ▶ Only use original Miele accessories. If other parts are used, warranty, performance and/or product liability claims will be invalidated.
- ▶ Miele will guarantee to supply functional spare parts for a minimum of 10 years and up to 15 years following the discontinuation of your coffee machine.

Cleaning and care

- ▶ Clean the coffee machine and the milk flask daily, particularly before using for the first time.
- ▶ All parts of the milk system need to be cleaned thoroughly and regularly. Milk contains bacteria which proliferate rapidly with inadequate cleaning.
- ▶ Do not use a steam cleaner to clean this machine. Steam could reach electrical components and cause a short circuit.
- ▶ If you do not utilise automatic descaling, you will need to descale the coffee machine manually on a regular basis. Miele cannot be held liable for damage resulting from not descaling the machine, using the wrong descaling agent or an unsuitable descaling solution concentration.
- ▶ Degrease the brew unit regularly with Miele cleaning tablets. Depending on the natural oil content of the coffee used, the brew unit can become blocked quite quickly.
- ▶ Used coffee grounds should be disposed of with the organic rubbish or on the compost heap. Do not empty them down the sink, as they could block it.

Warning and Safety instructions

For machines with stainless steel surfaces:

- ▶ Do not use sticky notes, adhesive tape, masking tape or other types of adhesive on the stainless steel surfaces.
- ▶ Stainless steel surfaces are susceptible to scratching. Even magnets can cause scratches.

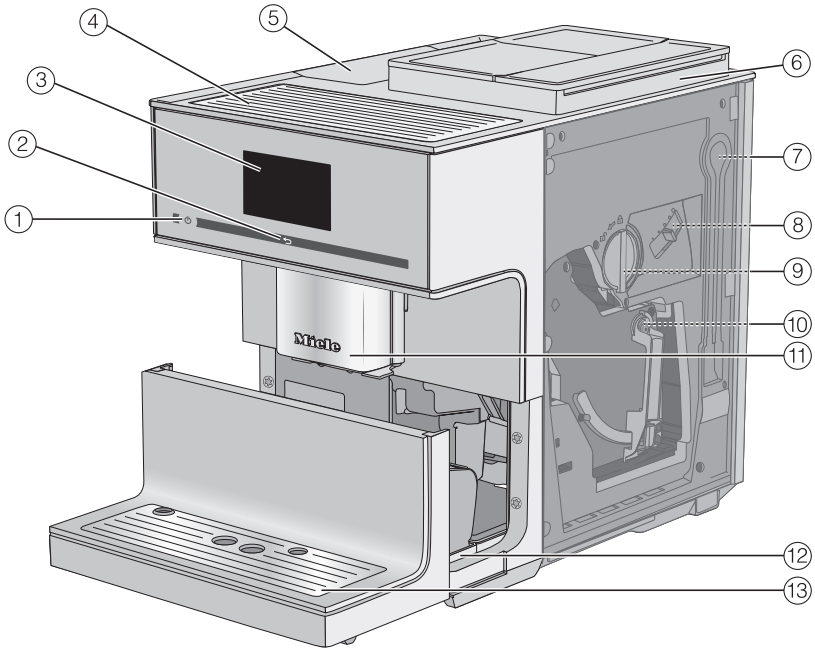

- ① On/Off button ①
- ② “Back” ← sensor
- ③ Touch display
- ④ Cup heating
- ⑤ Water container
- ⑥ Bean system with 3 bean containers
- ⑦ Park position for milk tube
- ⑧ Grinder setting
- ⑨ Ground coffee drawer with integrated coffee scoop
- ⑩ Brew unit
- ⑪ Height-adjustable central spout with lighting
- ⑫ Drip tray with lid and waste container
- ⑬ Lower panel with drip tray cover

Guide to the machine

Rear of machine

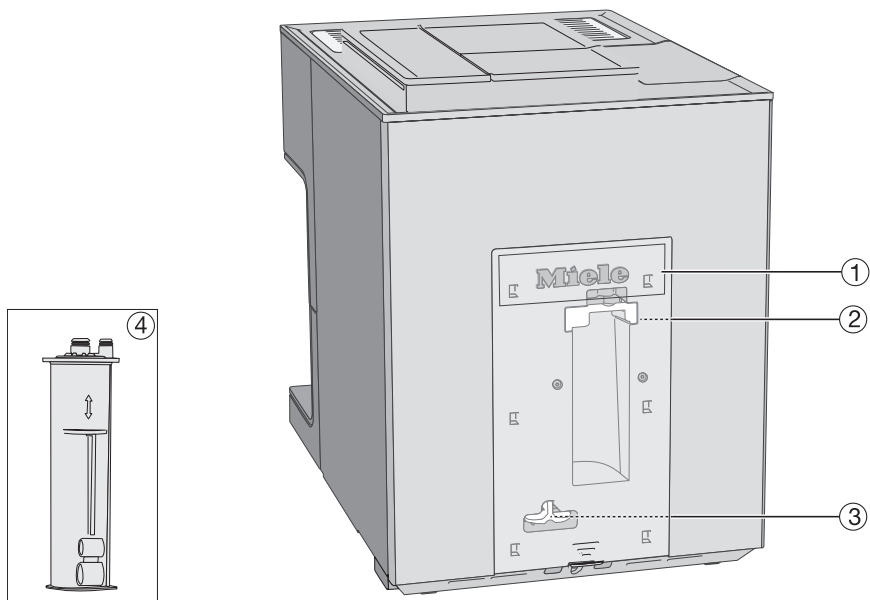

- ① Cover
- ② Descaling cartridge holder
- ③ Adapter
- ④ Miele descaling cartridge

Milk flask and milk siphon

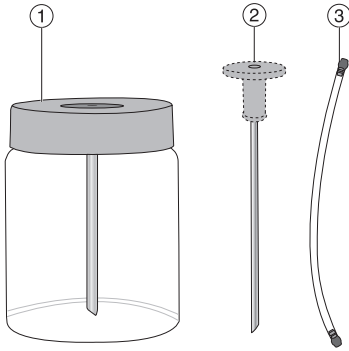

- ① Milk flask
- ② Milk siphon
- ③ Milk pipe

Central spout in detail

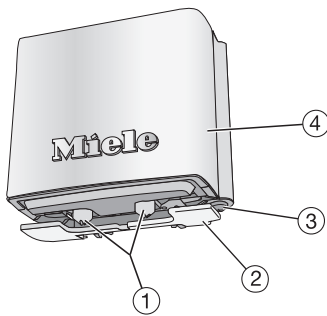

- ① Dispensing spouts for coffee and milk
- ② Cup sensor
- ③ Hot-water spout
- ④ Stainless steel cover

Unpacking and installing

Unpacking the coffee machine

- Unpack the coffee machine.
- Remove any protective foil and notes from the machine.

Tip: Please retain the original box and polystyrene pieces so that you can pack the machine securely, should you need to transport it in the future.

The drip tray cover can be found in the accessories pack.

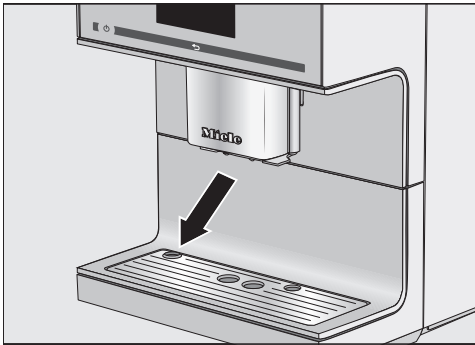

- Remove the protective foil from the drip tray cover and place the drip tray cover into the lower panel.

Accessories supplied

The following accessories are included with your coffee machine. Cleaning products are supplied depending on model.

- Milk flask MB-CM-G (capacity 0.5 l)
- Milk siphon
- Cleaning tablets for degreasing the brew unit (starter set)
- Miele descaling tablets (starter set)
- Miele descaling cartridge
- Cleaning brush

- Vacuum cleaner attachment for cleaning coffee chute

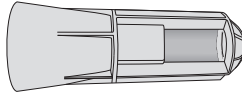

Setting up and connecting the coffee machine

⚠ Danger of overheating due to insufficient ventilation.

If the coffee machine is not sufficiently ventilated, the appliance can overheat.

Please ensure that there is adequate ventilation around the coffee machine.

Do not cover the coffee machine with tea towels etc. while it is in use.

If the coffee machine is installed in a niche, heat and moisture will accumulate inside the niche. This can result in damage to the coffee machine and/or furniture unit. Do not install the appliance in a niche.

Please observe the following installation instructions:

- The location of the machine must be dry and well ventilated.
- The ambient temperature of the room in which the machine is used must be between 16 °C and 38 °C.
- Do not place the coffee machine near a window in direct sunshine or right next to an appliance that gives off heat. These would subject the machine to ambient temperatures outside its permitted operating range.

Unpacking and installing

- The coffee machine must be set up on a level surface. The surface must be water resistant.
- The appliance door must be opened completely to remove the brew unit.
- Place the coffee machine in the location you want to use it.
- Clean the appliance thoroughly before filling it with mains tap water and coffee beans.
- Insert the plug of the coffee machine into the socket (see “Electrical connection”).
- Remove the water container and fill it with fresh, cold tap water. Only fill the water container up to the “max.” marker and then refit it in the machine.

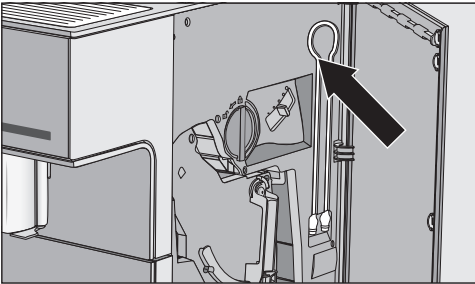

Tip: The milk pipework can be stored behind the service panel when not in use.

Operation

Touch display

The delicate touch display can be scratched by pointed or sharp objects, e.g. pens.
Only touch the display with your fingers.

If your fingers are cold, the touch display may not react.

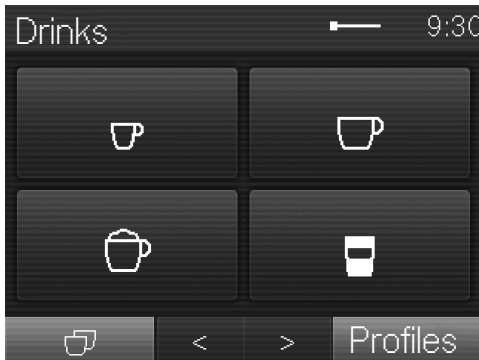

The display is split into three sections.

The menu name is displayed in the top left and the time in the top right of the display. Depending on the number of items in the menu, a scroll bar may also appear in the middle.

The middle row shows the current menu and options. The most popular drinks are depicted with symbols in the *Drinks* menu (see “Symbols in the display” for an explanation of the symbols).

You can scroll to the right or left using the < and > arrows at the bottom of the display. Context-dependent functions and menus can be found to the left and right of the arrow sensors.

Operation

You can only select options which are highlighted in light grey.

Each time you touch a possible option the relevant field lights up partially or completely **orange**.

Selecting or opening a menu

- Touch the field you want with your finger.

Scrolling

You can scroll left or right using the < and > arrow sensors.

- Touch the arrow sensor for the direction you want to go.

Exiting a menu (“Back” ← sensor)

- Touch the ← sensor to return to the previous screen.

Entries made before this which have not been confirmed with *OK* will not be saved.

Entering numbers

Use the numerical keypad to enter numbers, e.g. if you want to set a timer duration. The numerical keypad will appear automatically in the relevant menus.



- Touch the numbers you want.

Once you have entered an accepted value, the *OK* field will light up green.

- Touch *OK*.

You can delete one character at a time using the arrow sensor.

Entering letters

Profile names or the names for your own drinks are entered using a keyboard.

It is best to select short names (max. 8 characters).

Further letters or symbols can be accessed using the < and > arrow sensors. Numbers can be found by touching the 123 sensor.

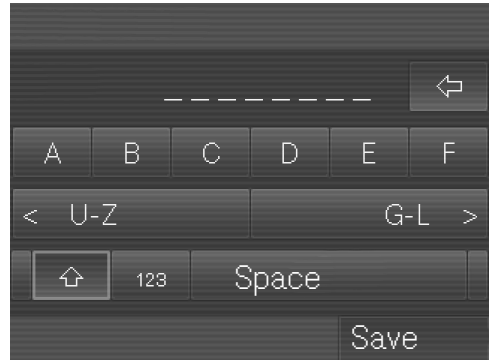















- Select the letters or characters you want.
- Touch *Save*.

Operation

Symbols in the display

The following symbols may also appear in the display in addition to the text:

Symbol	Explanation
	This symbol indicates the “Settings” menu and the “Language” menu option.
	Some settings, e.g. display brightness and buzzer/keypad volume, are selected using a bar chart.
	This symbol indicates that there is additional information and advice about using the coffee machine. Select <i>OK</i> to confirm the information.
	The Switch on at is activated (see “Settings - Timer”). The symbol and the desired switching on time appear in the display 23:59 hours before the coffee machine is due to switch on, as long as <i>On</i> or <i>Night dimming</i> is selected for the time display.
	The TeaTimer minute minder has been started (see “TeaTimer”). The remaining brewing time is shown next to the symbol.
	This symbol appears if the system lock is activated. Operation is locked.
	This symbol appears while the appliance is being descaled. (This symbol can also be found on the water container: fill up to this mark).
	This symbol appears if you call up the Profiles menu.

Symbol	Explanation
	This symbol and a fault code will appear if a fault occurs.
	The strength of the WiFi connection is shown under Settings Miele@home Connection status. Symbols represent the connection strength in increments from strong to not connected.
	Drinks menu symbols:
	Espresso
	Coffee
	Cappuccino
	Latte macchiato
	Two portions

Before using for the first time

When you connect the machine to the mains power, the following message will appear in the display: Miele - Willkommen.

When you switch the coffee machine on for the first time, you will be prompted to set the following:

- Language and country
- Date
- Time
- Clock display
- Automatic descaling
- Water hardness

■ Touch the On/Off sensor ①.

Setting the language

■ Select the language and touch *OK*.

You might also be asked for your location.

Set the date

■ Enter the current date and touch *OK*.

The setting is now saved.

Set the time

■ Enter the current time of day and touch *OK*.

The setting is now saved.

Time of clock display setting

You can choose one of the following options:

- **On:** the time and date are always visible in the display when the machine is switched off.

- **Off:** the display is dark when the machine is switched off.
 - **Night dimming:** the time and the date are displayed from 5:00 to 23:00.
- Select clock display and touch *OK*.

Depending on which option you select, the machine may use more energy. A message appears in the display to inform you of this.

Fit the descaling cartridge

Some information about automatic descaling will appear in the display. Further information and instructions can be found in “Automatic descaling” in these operating instructions.

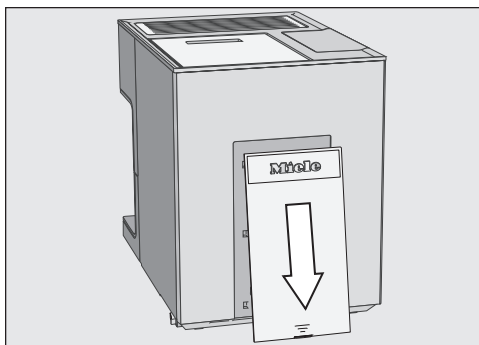

■ Remove the cover at the back of the coffee machine.

Before using for the first time

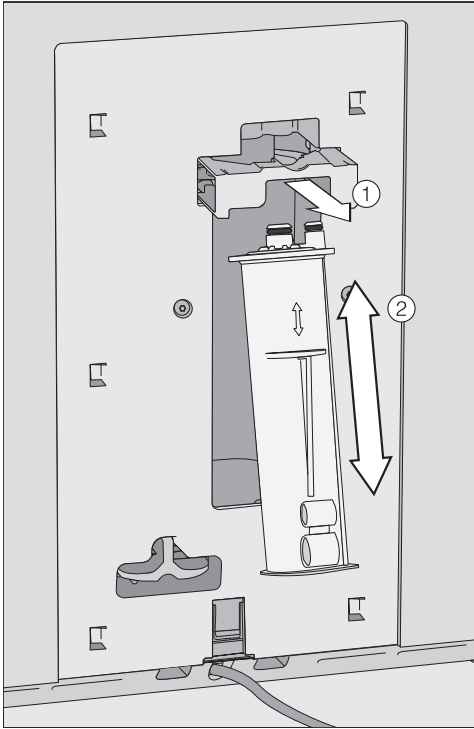

- If you want to change the start time, touch **Start time** and select the required time.

You can also change the start time for automatic descaling to a later time.

Set the water hardness level

Contact your local water supplier to find out your local water hardness range if necessary.

The machine has four programmable levels:

°dH	mmol/l	ppm (mg/l CaCO ₃)	Setting*
0 – 8.4	0 – 1.5	0 – 150	Soft
8.4 – 14	1.5 – 2.5	150 – 250	Medium
14 – 21	2.5 – 3.7	250 – 375	Hard
> 21	> 3.7	> 375	Very hard

* The hardness level shown in the display may differ from the hardness level in your area. You **must** follow the values in the chart to set your machine to your local hardness level.

- Select the hardness level you want and then touch **OK**.

The setting is now saved.

Miele@home communication enabled household appliance will appear in the display. You can connect your coffee machine to your local WiFi network (see “Networking”).

- Confirm the message with **OK**.

The coffee machine is now successfully set up for use. You can now fill the bean system.

- Pull the cartridge holder ① forwards and insert the descaling cartridge ②. Push the cartridge upwards as far as it will go.
- Push the holder back into position and replace the cover.

The next time the coffee machine is switched off, the descaling cartridge will fill with water. You will hear water being pumped into the cartridge at frequent intervals.

When a descaling cartridge is fitted, a message will appear regarding the current start time set for automatic descaling.

- Touch **OK**.

Before using for the first time

Set up the bean system

After setting up the coffee machine, you will be prompted to set up the bean system. The coffee machine will assist you when first filling and naming the bean containers.

- Touch Yes.

If you select No, the assistant for setting up the bean system will not be shown again.

Fill the bean container

Tip: Open one bean container lid at a time to prevent mixing of bean types when filling the bean system.

- Take one of the lids off.
- Fill the first type of beans in this container.
- Replace the lid.
- Repeat the steps for the other two bean containers.

Tip: Make a note of each type of bean if necessary.

After filling the bean containers, you can now name the types of beans.

Name the types of beans

The three bean containers are shown in the display as follows and are pre-named.

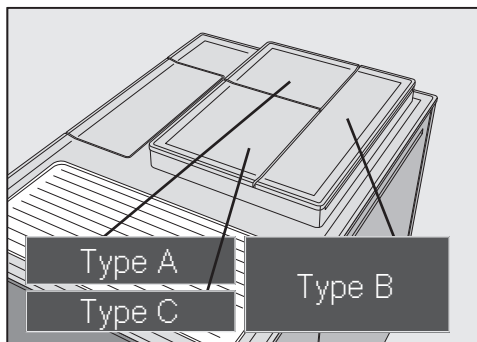

If you rename the bean containers, please note the following:

- Choose concise names (max. 8 characters).
- If you are using the same type of beans in two or three bean containers at the same time (for instance because you only use one type of bean), make sure you name them in the same way exactly.
- Enter the name you want for the Type A bean container and then touch Save.
- Now name the other two bean containers.

Continue will appear in the display. Now allocate bean types to the coffee drinks.

Allocate type of beans

Selected drinks are marked with .

- Select a bean type.
- Now select the drinks that are to be prepared with this type of bean.
- Select the next type of bean and allocate it to other drinks.

Before using for the first time

Any remaining drinks which have not been selected will be allocated to the third bean type.

You have set up the bean system and you can now prepare drinks.

To ensure that any coffee residues from the factory testing process are removed from the brewing system, please throw away the first 2 cups of coffee when using the coffee machine for the first time.

Bean system

Coffee or Espresso can be made from whole roasted coffee beans which are freshly ground for each portion. Your coffee machine has a bean system with three bean containers which can be filled with different types of beans or even just one type. You can allocate bean types to individual coffee drinks as you wish. Alternatively, you can create profiles with your own coffee drinks and allocate other bean types to these drinks which are different to the Miele profiles.

Alternatively, you can make coffee drinks with ready ground coffee (see “Making coffee drinks with ground coffee”).



Risk of damage to the grinder due to incorrect operation.

The coffee machine will be damaged if the bean container is filled with unsuitable substances such as liquids, ground coffee or coffee beans treated with sugar, caramel or similar.

In addition, green (unroasted) coffee beans or mixtures of coffee beans which contain green coffee beans can damage the grinder. Green coffee beans are very hard and still contain residual moisture. These can damage the coffee machine grinder as soon as grinding begins.

Only put roasted coffee beans in the bean container.

Tip: You can use a nut or seed grinder to grind green coffee beans. These types of grinder generally have a rotating stainless steel blade. You can then add the ground green coffee **one portion at a time** to the ground coffee chute and make the desired coffee drink (see “Making coffee drinks with ground coffee”).

If decaffeinated coffee beans are used after dispensing a drink with caffeinated beans, there may still be residues from the caffeinated beans in the grinder or brew chamber.

Please be aware that minimal residues of caffeinated beans may be present in the next drink that you make.

Changing bean system settings (Type of beans)

Start in the Drinks menu.

- Touch ↶.
- Touch Settings  and then Type of beans.
- Select a bean type.

You can now change the name or allocation.

Tip: If you want to allocate another type of bean to a coffee drink, you can also do this under Change parameters (see “Parameters - Type of beans”).

Renaming type of beans

The 3 bean containers are shown in the display as follows and are pre-named.

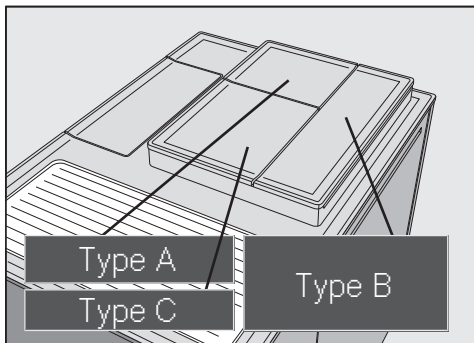

If you rename the bean containers, please note the following:

- Choose concise names (max. 8 characters).
- If you are using the same type of beans in two or three bean containers at the same time (for instance because you only use one type of bean), make sure you name them in the same way exactly.

- Touch Change name.

The editor will open in the display.

- Enter the name you want and then touch Save.

If you give identically named types of beans different names, you will then need to allocate coffee drinks to the newly named beans.

Changing bean type allocation

If you have created additional Profiles with coffee drinks to the Miele standard profile, the bean types can be individually allocated to individual drinks in each Profile.

- Touch Change allocation.

If you have set up one or more Profiles and at least one coffee drink, first select the Profile.

- Select the profile for which you want to allocate the type of beans.

All coffee drinks will be listed. The already allocated drinks will be indicated by a .

- Change the allocation as required and then touch OK.

Tip: If you touch All, you will have highlighted all coffee drinks and you can deselect the ones you do not want.

If you do not allocate a type of bean, you will be asked what type of bean you want to use for the coffee as you make it.

Filling the water container

⚠ Risk to health due to contaminated water.

Bacteria can develop in water which has been sitting in the water container for too long and is a risk to your health.

Change the water in the water container **every day**.

If the water container is not inserted correctly (e.g. sits too high or at an angle), water can leak from the outlet valve.

Check whether the surface that the water container sits on is soiled. If necessary, clean the surface that the water container sits on.

⚠ Risk of damage due to incorrect operation.

Unsuitable liquids such as hot or warm water or other liquids can damage the coffee machine. Bottled mineral water leaves too much limescale in the coffee machine.

Only use cold, fresh tap water to fill the water container.

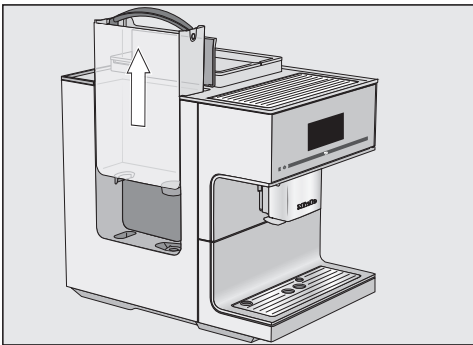

- Open the lid on the left-hand side of the coffee machine.
- Pull the water container up by the handle to remove it.
- Fill the water container with fresh, cold tap water up to the “max.” mark.
- Replace the water container and close the lid.

Switching the coffee machine on

- Touch the On/Off sensor ①.

The machine heats up and rinses the pipework. Hot water will run out of the central spout.

You can now make drinks.

If the coffee machine is already at operating temperature, rinsing will not take place.

While dispensing a drink or during maintenance processes, moisture builds up in the coffee machine. Once a drink has been dispensed or the appliance has been switched off, the internal fan will continue to run until the interior is sufficiently dehumidified. You will hear an accompanying noise.

Switching the coffee machine off

- Touch the On/Off button ①.

If coffee has been dispensed, the coffee machine will rinse the coffee pipework automatically before switching off.

Switching off for longer periods of time

If the coffee machine is not going to be used for a while, e.g. if you are going on holiday, remember to do the following:

- Empty the drip tray, the waste container and the water container.
- Clean all parts thoroughly, including the brew unit.
- If necessary, switch off the coffee machine and unplug it to disconnect it from the power supply.

The time of day set will be saved for a maximum of ten days and after that must be reset. Timer settings, profiles and other settings will be kept.

Spout adjustment

The central spout **cannot** be manually adjusted.

Before making the drink, the central spout moves down and the cup sensor stops it at the optimum height for the cups or glasses being used.

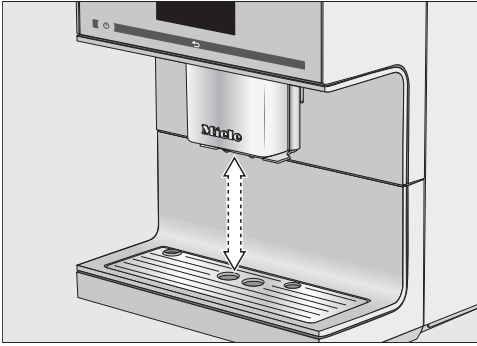

You can switch off spout adjustment. The central spout will then remain in the upper position while drinks are being made. When a maintenance programme is being carried out, the central spout will move to the height of the cleaning containers or into a maintenance position.

Tip: To move the central spout into the maintenance position, touch ↵ for three seconds.

If the coffee machine is switched off, the central spout components can be removed and cleaned at any time. The central spout will be in the middle position when switched off.

Switching the spout adjustment on and off

Start in the *Drinks* menu.

- Touch ↵.
- Touch *Settings* .
- Select *Spout adjustment*.
- Select the required option to switch spout adjustment on or off.
- Touch *OK*.

The setting is now saved.

⚠ Danger of overheating due to insufficient ventilation.

If the coffee machine is not sufficiently ventilated, the appliance can overheat.

Ensure that there is sufficient ventilation around the coffee machine, e.g. do not cover cups on the cup heating surface with a tea towel.

Cups should always be pre-heated to allow the flavour of the coffee to develop and its temperature to be retained.

You can pre-heat cups or glasses on the cup heating surface on the top of the coffee machine.

When the cup heating surface is activated, the cup rest will be heated continually until the coffee machine is switched off.

To switch cup heating on or off

Start in the **Drinks** menu.

- Touch **↶**.
- Select **Settings** and then **Cup heating**.
- Select the required setting to switch cup heating on or off.
- Touch **OK**.

The setting is now saved.

The coffee machine is delivered with cup heating switched off.

Pre-heating cups

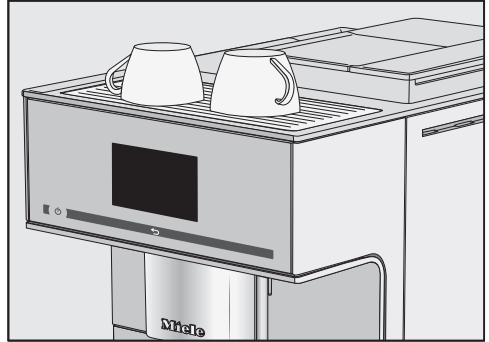

- Arrange the cups or glasses on the cup heating surface on the top of the coffee machine.

Making coffee with and without milk

The following drinks without milk can be made:

- **Ristretto** is a strong, concentrated espresso. It is prepared with the same amount of coffee as for an espresso but with a lot less water.
- **Espresso** is a strong aromatic coffee with a thick hazelnut brown coloured froth – known as the crema – on top. We recommend using espresso-roasted coffee beans to make an espresso.
- **Coffee** differs from espresso by the increased amount of water and the roast of the beans. We recommend using coffee beans of the correct roast to make the coffee.
- **Long coffee** is a coffee with considerably more water.
- **Long black.** This is made with hot water and two shots of espresso.
- **Caffè Americano** consists of espresso and hot water. The espresso is made first, then the hot water is dispensed into the cup.

 Danger of burning and scalding on the dispensing spouts.

The liquids and steam dispensed are very hot and can cause scalding.

Keep well away from the area underneath the spouts when hot liquids and steam are being dispensed.

Do not touch hot components.

Making a coffee

Further drinks can be displayed and selected using the > arrow sensor.

Start in the *Drinks* menu.



- Place a cup under the central spout.
- Touch the symbol or name of the coffee you want to make.

Dispensing will start.

Cancelling preparation

- Touch *Stop* or *Cancel*.

DoubleShot

Select the *DoubleShot* function if you would like a particularly strong and aromatic coffee. In this case, more coffee beans will be ground and brewed halfway through the brewing process.

Making coffee with and without milk

The shorter extraction time means that fewer unwanted aromas and bitter compounds will be released.

DoubleShot will appear while drinks are being made. DoubleShot can be activated for all drinks apart from “Ristretto” and “Long black”.

Making a DoubleShot of coffee

Start in the Drinks menu.

- Place a cup under the central spout.
- Select the type of coffee you want.

Dispensing will start and the following will appear underneath:



- Touch DoubleShot.

Double the quantity of coffee beans will be ground and brewed.

Making two portions

With “Two portions”  you can dispense two portions of a drink at the same time.



- Place a cup under each of the coffee dispensers in the central spout.
- Touch .

- Select a drink.

Two portions of the drink will be dispensed.

Coffee pot: making several cups of coffee one after the other

You can make several cups of coffee one after the other automatically with the Coffee pot function (max. 1 litre), e.g. to fill a coffee pot. Up to eight cups can be made in this way.

Start in the Drinks menu.

You can use the Coffee pot function twice in a row. After this, the coffee machine needs a cooling down time of one hour in order to avoid it being damaged.

- Place a sufficiently large container under the central spout.
- Select Coffee pot.
- Select the number of cups you want (3 to 8).
- Follow the instructions in the display.

Each portion of coffee will be brewed and dispensed individually. You can follow the process in the display.

Cancelling Coffee pot

You can interrupt preparation at any time.

- Touch Cancel.

Making coffee with and without milk

Making coffee drinks with ground coffee

You can make coffee using ready ground coffee. This allows you to make a decaffeinated coffee if the bean container is already filled with regular coffee beans, for example.

To do this, fill the ground coffee drawer with ground coffee. The coffee machine will use all the ground coffee which has been added to the chute to make the next coffee.

Only **one** portion of coffee or espresso can be made at a time.

Adding ground coffee

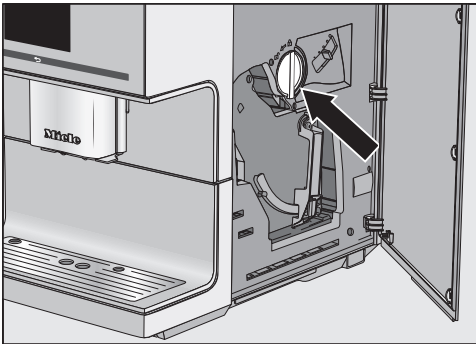

The coffee scoop is integrated into the ground coffee drawer.

- Open the appliance door.
- Turn the handle (see arrow) to the left to remove the ground coffee drawer.

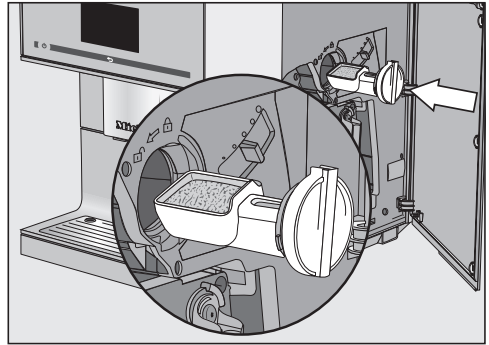

- Fill the coffee scoop with ready ground coffee. Push the ground coffee drawer horizontally into the ground coffee chute.

In order to not overfill the brew unit, place a maximum of **2** level scoops of coffee in the ground coffee chute.

- Turn the handle clockwise to fill the brew unit with the ground coffee and to close the ground coffee chute.
- Close the appliance door.

Use ground coffee? will appear in the display.

Making coffee with ground coffee

- Touch Yes.

You can now select which type of drink you would like to make with ground coffee.

- Place a cup under the central spout.
- Select a drink.

The coffee will now be made.

If you select No, the ground coffee will be disposed of in the waste container without being brewed. The appliance rinses.

Making coffee with milk

The following drinks with milk can be made:

- **Cappuccino** consists of approx. 2 thirds milk froth and 1 third espresso.
- **Latte macchiato** consists of 1 third each of hot milk, milk froth and espresso.
- **Caffè latte** consists of coffee and hot milk.
- **Cappuccino italiano** has the same proportions of milk froth and espresso as a cappuccino. The difference is that the espresso is added first and then the milk froth.
- **Espresso macchiato**. This is an espresso with a small amount of milk froth on top.
Select a cup which can hold at least 100 ml for this drink.
- **Flat white** is a large cappuccino: lots of espresso with plenty of milk froth.
- **Café au lait**. This is an espresso with slightly hotter milk.

Hot milk or **milk froth** can also be made.

Tip: Using cold cow's milk (< 10 °C) with a protein content of at least 3 % will produce the perfect milk froth. You can select milk with a fat content according to preference. With whole milk (at least 3.5 % fat), the milk froth will be slightly creamier than with low-fat milk.

 Danger of burning and scalding on the dispensing spouts.

The liquids and steam dispensed are very hot and can cause scalding.

Keep well away from the area underneath the spouts when hot liquids and steam are being dispensed.

Do not touch hot components.

Milk or milk alternatives (e.g. soy milk) containing added sugar can clog up the milk pipe and the rest of the milk pipework. Residues from unsuitable liquids can interfere with milk preparation.

The milk used must not contain any additives.

Only use pasteurised cow's milk.

As soon as you select a drink containing milk, the machine will start to heat up. The milk will be drawn up into the central spout where it is heated by steam and also frothed for drinks requiring milk froth.

If you have not made any milk drinks for a while, rinse the milk pipework thoroughly before making the first drink.

Tip: The milk pipework is easier to connect to the aperture in the central spout if the central spout is in the maintenance position. Touch the  button for 3 seconds.

Making coffee with milk

You can prepare milk with the milk siphon or milk flask.

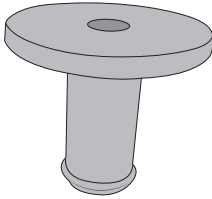

There is one connecting piece included in the scope of delivery which can be inserted either into the milk siphon or into the milk flask lid.

The appliance is supplied with the connecting piece already inserted into the milk flask lid. The connecting piece is easy to push out from the inside of the milk flask lid.

Using a milk carton with the milk siphon

The milk siphon enables you to prepare milk directly from milk cartons or other suitable containers.

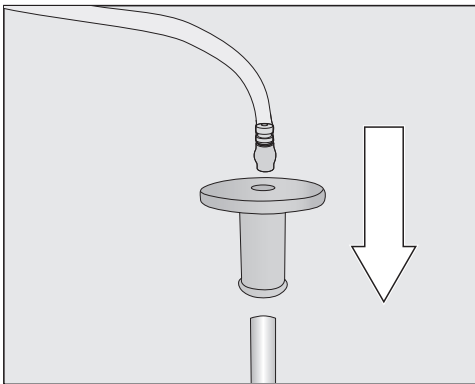

- First insert the connecting piece onto the long stainless steel tube and then connect the milk pipe to the connecting piece.

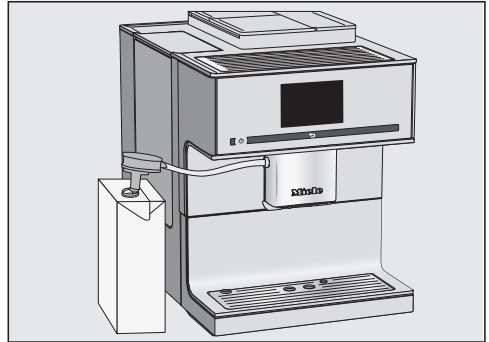

- Open the milk carton and dip the milk siphon into the milk. Place the milk carton next to the coffee machine.
- Connect the milk pipe to the aperture in the central spout.

Tip: Rinse the milk siphon under running water after use.

Making coffee with milk

The milk flask

Milk is **not** cooled in the milk flask. For high-quality milk froth, always use cold milk (< 10 °C).

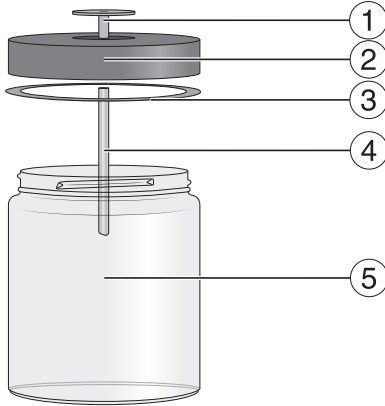

- ① Connecting piece
- ② Lid
- ③ Sealing ring
- ④ Stainless steel tube
- ⑤ Glass

Using the milk flask

- Insert the connecting piece into the lid from above until everything sits flush.
- Connect the stainless steel tube to the inside of the lid. Make sure that the slanted end of the stainless steel tube is pointing downwards.
- Fill the milk flask with milk up to a maximum of 2 cm below the rim. Seal the milk flask with the lid.

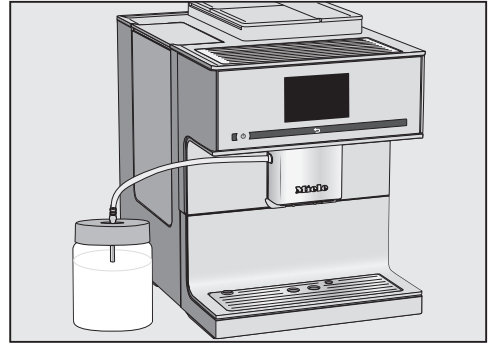

- Place the milk flask next to the coffee machine.
- Insert the milk pipe into the lid of the milk flask and connect the flask to the coffee machine by attaching the pipe to the aperture in the central spout.

Making drinks with milk

The milk pipework must be connected to the central spout and submerged in sufficient cold milk.

Start in the *Drinks* menu.

- Place a suitable container underneath the central spout.
- Select a drink.

Dispensing will start.

Cancelling a drink

You can finish dispensing individual drink components early, e.g. if the cup is not big enough.

Cancelling individual drink components

- Touch *Stop*.

Cancelling the entire drink preparation

- Touch *Cancel*.

Tea

 Danger of burning and scalding on the hot water spout!

The liquids and steam dispensed are very hot and can cause scalding.

Keep well away from the area underneath the hot water spout when hot liquids and steam are being dispensed.

Do not touch hot components.

This machine is not intended for commercial or scientific purposes. Temperatures given are approximate and can vary according to ambient conditions.

To make tea you can select from the following options:

- **Green tea** approx. 80 °C
- **Herbal tea** approx. 90 °C
- **Fruit tea** approx. 90 °C
- **Black tea** approx. 90 °C

The type of tea determines the preset temperature.

The respective dispensing temperatures are recommended by Miele for making black tea, green tea, herbal or fruit tea.

Follow the instructions for making tea on the tea packaging.

The taste of the tea will be affected by the type of water used. Water should be as soft as possible to allow the aroma to develop.

Whether you use loose tea leaves, blended tea or tea bags depends on your own personal preference.

The amount of tea and the brewing time will vary depending on the type of tea. Always follow the recommendations of the manufacturer on the packaging or of the retailer. The amount of hot water used can be adjusted depending on the type of tea and the size of the cup (see “Portion size”)

Tip: Store the tea in a cool, dark place in tightly sealed containers. It is best to buy smaller amounts to prevent loss of aroma.

TeaTimer

You can use the TeaTimer to start a minute minder when making tea. A brewing time of 2 minutes is preset as standard. You can adjust the preset brewing time according to your preferences (between 1:00 and 23:59 minutes).

The TeaTimer can be started twice consecutively.

If you have started a TeaTimer, while the brewing time is counting down you can continue to use the coffee machine as normal. An audible tone will sound after the brewing time has elapsed.

If you have switched off audible tones, you will not be reminded when the brewing time has finished.

Switching the TeaTimer on and off

Start in the **Settings**  menu.

■ Select **Timer** and then **TeaTimer**.

- **On:** the TeaTimer is displayed while the hot water is being prepared. The TeaTimer can be started after preparation.

- Off: the TeaTimer is not displayed.

- Select the setting you want and confirm with **OK**.

Making tea

The hot water spout is located to the right of the central spout.

Use the arrow sensor > to display and select the types of tea. Different types of tea can be found in the drinks menu after Milk froth.

Start in the Drinks menu.

- Pour loose tea into a tea filter or similar or take a tea bag from the packet.
- Place the tea filter or the tea bag in the tea cup.



- Place the cup under the hot water spout.
- Select the type of tea from the display.

Hot water will be dispensed into the cup.

You can now start the minute minder for brewing time if the TeaTimer is switched on.

Starting the TeaTimer

TeaTimer appears in the bottom left of the display.

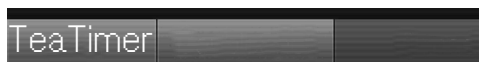

- Touch TeaTimer.

TeaTimer will be selected. After dispensing, the editor will open with a suggested time.

- Adjust the brewing time if necessary and touch **OK**.

An audible tone will sound after the brewing time has elapsed.

- Now remove the tea leaves or the tea bag.

Cancelling tea preparation

- Touch **Stop** or **Cancel**.

Tea pot: making several cups of tea, one after the other

You can make several cups of tea one after the other automatically with the Tea pot function (max. 1 litre), e.g. to fill a tea pot. Up to eight cups can be made in this way.

Start in the Drinks menu.

- Place the tea or tea bag in the tea pot.
- Place a suitably sized tea pot under the hot water spout.
- Select **Tea pot**.
- Select the type of tea you want.
- Select the number of cups you want (3 to 8).
- Follow the instructions in the display.

Tea

The teapot will be filled. You can follow the process in the display.

You can interrupt preparation at any time:

- Touch Cancel.

⚠ Danger of burning and scalding on the hot water spout!

The liquids and steam dispensed are very hot and can cause scalding.

Keep well away from the area underneath the spouts when hot liquids and steam are being dispensed.

Do not touch hot components.

The hot water has a temperature of approx. 90 °C when dispensed.

The amount of hot water used can be adjusted depending on the size of the cup (see “Portion size”).

Start in the Drinks menu.

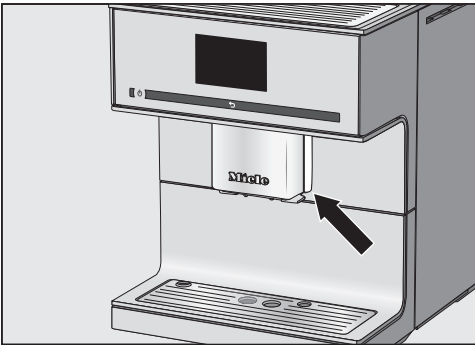

- Place a suitable container underneath the hot water spout.
- Select Hot water.

Dispensing will start.

Cancelling a drink

- Touch Stop or Cancel.

Parameters

You can individually adjust the following parameters for each drink:

- Ground quantity
- Brewing temperature
- Pre-brewing
- Type of beans

Changing drink parameters

Start in the **Drinks** menu.

- **Select** Process.
- **Touch** Change drink.
- **Select** a drink.

Now you can adjust the portion size (see “Portion size”) or set the drink parameters.

- **Touch** Drink parameters.
- **Select** Amount of coffee, Brew temperature, Pre-brewing or Type of beans.
- **Select** the setting you want and touch **OK**.

The overview of drink parameters will appear in the display.

- **Touch** **OK** again to save your changed settings.

Quantity of coffee

The coffee machine can grind and brew 7.5–12.5 g of coffee beans per cup. The greater the quantity, the stronger the coffee.

The quantity of coffee is **too low** if the espresso or coffee lacks body.

Increase the quantity of coffee so that more ground coffee is brewed.

The quantity of coffee is **too high** if the espresso or coffee tastes bitter.

Decrease the quantity of coffee so that less ground coffee is brewed.

Brewing temperature

The brewing temperature must be adapted to the beans you are using and how they are roasted. It also varies depending on whether you are making espresso or coffee.

Some bean types are sensitive to high brewing temperatures, resulting in an impaired taste. If your coffee tastes bitter, the brewing temperature you have selected might be too high.

Espresso is usually brewed at higher temperatures.

Pre-brewing the ground coffee

When the pre-brewing function is turned on, the ground coffee is first moistened with a little hot water. The ground coffee swells a little. The remaining amount of water is then pressed through the moistened coffee grounds shortly after. If your coffee tastes too bland and you want to add some spice and richness, try the “Pre-brewing” function. Depending on the type of coffee used, pre-brewing can intensify the taste.

You can set a short or long duration for pre-brewing or turn the “Pre-brewing” function off completely.

Tip: We particularly recommend using the “Pre-brewing” function to make coffee.

Type of beans

You can display which type of bean is saved for the coffee drink or change the allocation.

Grinder setting

When the beans are ground correctly, the coffee or espresso will flow evenly into the cup with a good crema. The crema should have an even hazelnut brown colour.

The grinder setting you select will be used for all coffee drinks.

There are various ways to tell whether the coffee grinder is set correctly.

The coffee has been **too coarsely** ground if:

- espresso or coffee flows into the cup too quickly,
- the crema is very pale and uneven,

Set a finer grinder setting.

The coffee has been **too finely** ground if:

- espresso or coffee flows into the cup very slowly,
- the crema is dark brown,

Set a coarser grinder setting.

The grinder setting is set for all bean types.

- Open the appliance door.

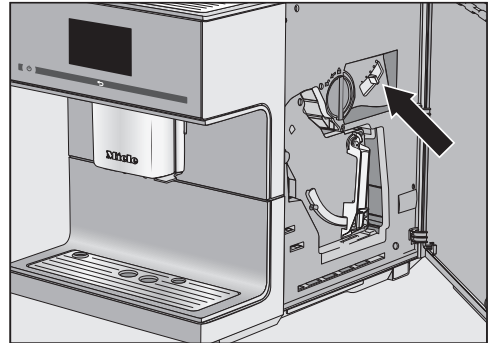

- Push the slide control a maximum of one setting to the left (for finer grinding) or one setting to the right (for coarser grinding).
 - Close the appliance door.
 - Make one cup of coffee.
- Adjust the grinder setting again.

Portion size

The flavour of the coffee produced depends not only on the type of coffee, but also on the amount of water used. You can programme the amount of water for all coffee drinks, tea and hot water to suit the size of your cups and to suit the type of coffee you are using. This does not alter the amount of coffee used.

For coffee drinks with milk you can also set the amount of milk or milk froth to suit your personal taste. You can also set the portion sizes for hot milk and milk froth.

The changed portion size is always saved in the current profile. The name of the current profile is shown in the top left of the display.

If the water container becomes empty whilst making a drink, the machine will stop programming the portion size. The portion size will **not** be saved.

Start in the **Drinks** menu.

- Place the cup you want under the central spout or hot water spout.
- Select **Process**.
- Touch **Change drink**.
- Select the drink and then touch **Portion size**.

If you have selected a drink with milk or tea, portion programming will start immediately. **Portion size** does not need to be opened separately.

The drink will be made and **Save** will appear in the display, as soon as the minimum dispensing amount is reached.

- When the cup is filled to the level you want, touch **Save**.

If the maximum amount is reached, preparation stops and the maximum possible amount is saved.

If you want to change the portion size for coffee drinks made with milk or hot water, the ingredients which make up the drink will be saved one after the other while the drink is being made.

The programmed mix of ingredients and portion sizes will now be dispensed every time that particular drink is selected.

You can reset portion sizes and parameters individually or for all drinks back to their factory default setting.

Start in the Drinks menu.

- Select Process.

Resetting a drink

- Touch Reset drink.

- Select a drink.

Reset drink to default settings? will appear in the display.

- Touch Yes to confirm.

Resetting all drinks

- Touch Reset all drinks.

Reset all drinks to default settings? will appear in the display.

- Touch Yes to confirm.

Profiles

In addition to the Miele drinks menu (Miele profile), you can enter up to 10 individual profiles to cater for different tastes and preferences.

The portion quantities and parameters for coffee and milk drinks, hot water and tea can be adjusted in each profile.

The name of the current profile is shown in the top left of the display.

Creating a profile

- Touch Profiles.
- Touch Create profile.

The editor will open in the display.

- Enter the name you want (max. 8 characters) and then touch Save.

The profile is created. You can now create drinks (see “Profiles: creating and processing drinks”).

Opening the Profiles menu and selecting a profile

Start in the Drinks menu.

- Touch Profiles.
- Select the profile you want.

You can now make drinks from the profile, change the parameters for individual drinks or process profiles.

Processing profiles

When you have created at least one profile you can choose from the following options under Process:

- **Change name** if you want to alter the name of a profile.

- **Delete profile** if you want to delete a profile.
 - **Change profile** to set whether the coffee machine automatically always reverts to the Miele drinks menu or retains the last selected profile.
- Select Process.

Change name

- Touch Change name.
- Select the profile you want.
- Change the name as you wish and then touch Save.

The changed profile name is saved.

Deleting a profile

- Touch Delete profile.
- Touch the profile you want and then touch OK

The profile will be deleted.

Change profile

You can programme the coffee machine so that it changes back to the Miele standard profile automatically after each drink is dispensed or so that it retains the most recently selected profile.

- Touch Change profile.

You now have the following options:

- **Manually:** the selected profile will remain active until you select another profile.
- **After each use:** The machine will change back to the Miele drinks menu automatically after a drink is dispensed.

- **When switched on:** Each time the machine is switched on it will automatically select the Miele drinks menu regardless of which profile was set before the machine was last switched off.
- Select the required option and touch *OK*.

Profiles: creating and processing drinks

You can save frequently made drinks in a profile with your own individual settings (see “Profiles”).

You can also change the names of your drinks and delete any unwanted drinks from your profile. You can save a maximum of 10 drinks in a profile.

Start in the **Drinks** menu. First open the profile you want:

- Touch **Profiles**.
- Select the profile you want.

The name of the current profile is shown in the top left of the display.

Creating a drink

You can create new drinks based on existing drinks.

- Touch **Create drink**.
- Now select a drink.
- Change the portion size or drink parameters for this drink.

Preparation will be begin and you can save the portions of each component as desired.

- Enter a name for the new drink (maximum 8 characters) and touch **Save**.

The newly created drink will appear in the profile.

Changing a drink: changing the portion size(s), drinks parameters and names

The desired profile with the newly created drinks will appear in the display.

- Select **Process drink**.

- Touch **Change drink**.
- Select a drink.

You can now either change the portion size(s), drinks parameters or the names as described.

Delete drink

The desired profile with drinks will appear in the display.

- Select **Process drink**.
- Touch **Delete drink**.
- Select the drink and touch **OK**.

The entry will be deleted.

Start in the Drinks menu.

- Touch Profiles.
- Select the profile you want.

The name of the profile selected will be shown in the top left of the display. Now you can make the drink you want.

- Place a suitable container underneath the central spout.
- Select a drink.

Dispensing will start.

Expert mode

In Expert mode you can change the portion size while the drink is being made. The setting will **not** be saved and will only apply for the current drink.

Expert mode is not available if you have selected DoubleShot or two portions ☞.

Switching Expert mode on and off

Start in the Drinks menu.

- Touch ↶.
- Select Settings ☰ and then Expert mode.
- To switch Expert mode either on or off, select the option you want.
- Touch OK.

If Expert mode has been switched on, you can now change the portion size while the drink is being dispensed.

Expert mode: changing the portion size

Start in the Drinks menu.

The portion size can only be changed when the respective ingredient is being processed while the drink is being made.

Changing portion size

- Select a drink.

Dispensing will start. You can adjust the portion size while it is being dispensed, e.g. individually change the amount of hot milk, milk froth and espresso for Latte macchiato.

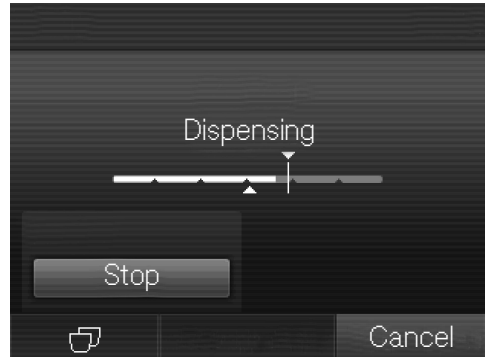

- Touch the segments and adjust the indicator (small triangle) as you wish.

You can use the “Settings” menu to customise the coffee machine to suit your requirements.

Some settings which can be found in the Settings menu are described in their separate sections in the operating instructions.

Opening the Settings menu

Start in the Drinks menu.

- Touch ↩.
- Select Settings .

You can now check or make alterations to settings.

The settings which are currently selected will be marked in colour.

Touching ↩ takes you back to the previous menu.

Changing and saving settings

Start in the Settings  menu.

- Select the option you want to change.
- Select the setting you want and confirm with **OK**.

The setting is now saved.

Language

You can select the language (and location variant of that language) for all display text.

Tip: If you select the wrong language by mistake, you can find the “Language” option again via the  symbol.

Time

You can set the time display, the clock format and the time.

Display (Clock display)

You can choose one of the following options:

- On: the time and date are always visible in the display when the machine is switched off.
- Off: the time and date are not visible in the display when the machine is switched off.
- Night dimming: the time and the date are displayed from 5:00 to 23:00.

Depending on which option you select, the machine may use more energy. A message appears in the display to inform you of this.

Clock format

The options are:

- 24 hour display (24 h)
- 12 hour display (12 h (am/pm))

Setting

Set the hours and the minutes.

If the coffee machine has been connected to a WiFi network and is signed into the Miele app, the time will be synchronised based on the location setting in the Miele app.

Timer

There are two timers with the following functions:

The coffee machine

Settings

- switches on at a particular time, e.g. in the morning for breakfast (Switch on at).
- switches off at a particular time (Switch off at),
- switches off after a particular length of time if none of the sensors has been touched or a drink has not been made (Switch off after; available with Timer 1 only).

You can allocate the timer functions to individual days of the week.

For Switch on at and Switch off at, the timer must be activated and at least one day of the week allocated.

Selecting a timer

The options are:

- **Timer 1:** Switch on at, Switch off at, Switch off after
- **Timer 2:** Switch on at, Switch off at

Switch on at

The coffee machine will **not** switch on at the required time if you have activated the system lock. The timer settings are deactivated.

If the coffee machine has switched itself on automatically **three times** via the Switch on at timer function and no drinks have been dispensed, the machine will not switch itself on again automatically. This prevents the coffee machine from switching itself on unnecessarily, for example, whilst you are away on holiday.

The programmed times will, however,

remain in memory and will be reactivated after manually switching the machine on again.

Switch off at

In the event of a longer absence the programmed times will remain in memory and will be reactivated after manually switching the machine on again (see “Switch on at”).

Switch off after

The Switch off after timer function is only available in Timer 1.

If none of the sensors have been touched or no drink has been made, the coffee machine will switch itself off after 20 minutes to save energy.

You can change this to another time of between 20 minutes and 9 hours.

Allocating days of the week

The selected day of the week will be marked by .

- Select the required day of the week.
- When all required days of the week are marked, touch *OK*.

Activating and deactivating the timer

If you have selected On or Night dimming for the time display:

when Switch on at is activated for the timer, the ☀ symbol and the desired switching on time will appear in the display 23:59 hours before.

If the system lock is activated, the Switch on at option for the timer cannot be selected.

Select the timer function you want to use. The selected timer function will have a next to it.

Eco mode

Eco mode is an energy-saving mode. The system does not heat up until someone starts making a drink.

Eco mode is activated by default.

Lighting

You have the following options:

- The machine is switched on: set the brightness.
- The machine is switched off: set the brightness and set the time the lighting should switch off.

When the coffee machine is switched on, it remains lit up for a certain length of time after the last action. This time cannot be adjusted.

Water hardness

If a descaling cartridge is **not** fitted and you descale the coffee machine using descaling tablets, the machine should be set to the local water hardness. A prompt to descale the machine will then appear in the display at the correct time.

Programme the coffee machine to the water hardness level of your area so that it functions correctly and does not get damaged.

Contact your local water supplier to find out your local water hardness range if necessary.

If you are using bottled drinking water, e.g. mineral water, select settings according to the calcium content. The calcium content is specified on the label of the bottle in mg/l Ca²⁺ or ppm (mg Ca²⁺/l).

Do not use carbonated water.

Tip: If your water hardness is > 21 °dH (3.8 mmol/l), we recommend using bottled drinking water instead (< 150 mg/l Ca²⁺). This will mean your coffee machine will need to be descaled less often and there will be less impact on the environment because less descaling agent will be used.

The machine is programmed ex-works to hardness level 3.

The machine has four programmable levels:

°dH	mmol/l	ppm (mg/l CaCO ₃)	Setting*
0–8.4	0–1.5	0–150	Soft 1
8.4–14	1.5–2.5	150–250	Medium 2
14–21	2.5–3.8	250–375	Hard 3
> 21	> 3.8	> 375	Very hard 4

* The hardness level shown in the display may differ from the hardness level in your area. You **must** follow the values in the chart to set your coffee machine to your local water hardness level.

Info (display information)

The Info option allows you to see the number of portions made for each drink.

Settings

You can also see how many portions can be dispensed before the brew unit needs to be degreased (No. of drinks until).

To return to the previous display, touch ↩.



System lock

You can lock the coffee machine to prevent it being used without your knowledge, by children, for example.

Activating and deactivating the system lock

When the system lock is activated, the timer settings for *Switch on at* are deactivated. The coffee system will **not** switch on at the time set.

Overriding the system lock

If you touch the On/Off  sensor,  will appear.

- Touch  as long as a relevant instruction appears in the display.

As soon as you switch the coffee machine off, the system lock will be activated again and the coffee machine is locked.

Miele@home

The following options may appear under Miele@home:

- Set up: this option only appears if the coffee machine has never been connected to a WiFi network or if the Network configuration has been reset.

- Deactivate*/Activate*: the settings for the WiFi network are retained, but the network is switched on or off.
- Connection status*: information about the WiFi connection is displayed. The symbols indicate the strength of the connection.
- Set up again*: the settings for the current WiFi network will be reset. The WiFi connection will be set up again.

* This menu option appears if Miele@home has been set up and the coffee machine has – where applicable – been connected to a WiFi network.

Display brightness

You can set the display brightness using the bar chart.

Volume

You can set the volume of the buzzer and keypad tones using the bar chart.

Service

Evaporate

The coffee machine should be evaporated before it is stored for a long period of time or transported any distance (see “Transporting the machine”)

Demo mode

Do not activate this setting for domestic use!

The coffee machine can be demonstrated in the showroom using Demo mode. In this mode the machine lights up but drinks cannot be made or actions taken.

Factory default

You can reset the coffee machine to its factory default settings.

Please refer to the “Overview of available settings” chart for the factory settings.

Appliance settings

The following will **not** be reset:

- The number of drinks and the appliance status (No. of portions until appliance needs descaling, ...
Degreasing the brew unit
- Language
- Time and date
- Profiles and their associated drinks (the allocation of bean types to drinks is reset)

The Descaling timer is reset to 22:00.

Network configuration

The settings for the WiFi network will be reset.

The network configuration should be reset whenever the coffee machine is being disposed of or sold, or if a used coffee machine is being put into operation. This is the only way to ensure that all personal data has been removed and the previous owner will no longer be able to access the coffee machine.

Networking

Your coffee machine is WiFi enabled and can be operated via the Miele@mobile app using a mobile device, e.g. smartphone or tablet.

Please ensure you adhere to the warning and safety instructions in these operating instructions even when you are operating the coffee machine via the Miele@mobile app.

Energy consumption increases when the coffee machine is connected to a WiFi network. This applies even when the coffee machine is switched off.

Setting up the network (Miele@home)

Networking is deactivated ex-works.

To connect the coffee machine to a WiFi network, the Miele@mobile app must be installed on a mobile device (e.g. smartphone). You sign in to the app with a user account.

The Miele@mobile app can be downloaded free of charge from the relevant app store. Please ensure you have the required version of your operating system.



- Make sure that the signal of your WiFi network is sufficiently strong in the place where you want to set up your coffee machine.

Start in the Settings  menu.

- Select Miele@home and then Set up.

You can now select the connection method.

- via App
- via WPS

Networking the coffee machine via the Miele@mobile app

Additionally you will require the following to sign in:

- Your WiFi network password
- The password of your coffee machine

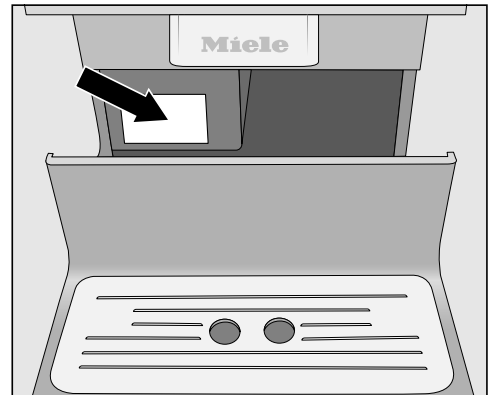

The password of your coffee machine is the serial number located on the data plate.

Note that the first digit you enter must not be "0". Start with the following digit. If your serial number is, for example, "023423585" your password will be "23423585".

- Select the connection method Via App.
- Start the Miele@mobile app and following the instructions in the app.

Connection successfully established appears when the coffee machine is connected to a WiFi network.

- Confirm with **OK**.

Networking the coffee machine via WPS

To use the Via WPS connection method, your router must have the WPS function.

- Select the connection method **Via WPS**.
- Follow the instructions in the display.

Connection successfully established appears when the coffee machine is connected to a WiFi network.

- Confirm with **OK**.

To use the Miele@home functions, you need to sign on your coffee machine in the app as well.

- Follow the prompts in the app.

Setting up the network again

If your WiFi network has changed, you can set up Miele@home for your coffee machine again.

Start in the **Settings**  menu.

- Select **Miele@home** and then **Set up again**.
- Follow the instructions in “Setting up the network”.

Remote control



Remote control is only visible when the coffee machine is connected to a WiFi network.

You can change the coffee machine settings, for example, when remote control is switched on in the Miele@mobile app. To start making a drink via the app, MobileStart must be additionally activated.

Remote control is activated ex-works.

Switching remote control on or off

Start in the **Drinks** menu.

- Touch .
- Select **Settings**  and then **Remote control**.
- Select the required option to switch remote control on or off.

Networking

MobileStart

With MobileStart you can start making a drink, for example, via the Miele@mobile app.

 Danger of burning and scalding on the dispensing spouts.

If liquids or steam are dispensed while the machine is unsupervised, persons may burn themselves if they place body parts under the central spout or touch hot components.

Ensure that no one, especially children, can be harmed if the machine is operated without supervision.

Automatic descaling and activation rinsing will not start if MobileStart is activated.

If the coffee machine is being operated manually, it cannot be operated via the app. Operation on the machine takes precedence.

To start making drinks remotely, MobileStart must be activated. Make sure that the coffee machine is ready to use, for example check that the water container is sufficiently filled. Place a sufficiently large, empty cup under the central spout.

MobileStart will be deactivated after 24 hours.

If you are making a drink with MobileStart, you will be notified of drink dispensing with acoustic and optical signals. These signals cannot be changed or switched off.

Switching MobileStart on and off

If you want to use MobileStart, the Remote control option must be switched on.

Start in the Drinks menu.

- Touch ↶.
- Select MobileStart.
- Select the required option to switch remote control on or off.

You can now starting making a drink via the app. Follow the prompts for doing this.

RemoteUpdate

The RemoteUpdate menu option is only displayed and can only be selected if the requirements for using Miele@home have been met.

The RemoteUpdate function allows the software on your coffee machine to be updated. If an update is available for your coffee machine, it will automatically download it. Updates will not be installed automatically. They must be initiated manually.

If you do not install an update, you can continue to use your coffee machine in the usual way. However, Miele recommends installing updates.

Activating/deactivating

The RemoteUpdate function is activated by default. Available updates will be downloaded automatically but will only be installed if you initiate installation manually.

Deactivate RemoteUpdate if you do not want any updates to be downloaded automatically.

Running RemoteUpdate

Information about the content and scope of an update will be provided in the Miele@mobile app.

A message will appear in your coffee machine display if a software update is available.

You can install the update immediately or postpone this until later. When the coffee machine is switched on again, you will be reminded about the update.

Deactivate RemoteUpdate if you do not want to install the update.

The update may take several minutes to install.

Please note the following information about the RemoteUpdate function:

- You will only receive a message when an update is available.
- Once an update has been installed, it cannot be undone.
- Do not switch off the coffee machine during an update. Otherwise, the update will be aborted and will not be installed.
- Some software updates can only be carried out by the Miele Customer Service Department.

Cleaning and care



Risk to health due to inadequate cleaning

Heat and moisture inside the coffee machine can cause coffee residues to become mouldy and/or milk residues to go off and pose a risk to health.

Carefully clean the coffee machine regularly.

Overview of cleaning intervals

Recommended frequency	What do I have to clean/maintain?
Daily (at the end of the day)	Water container
	Waste container
	Drip tray and drip tray cover
	Milk flask
	Milk siphon
	Cup rim sensor
Once a week (more often if heavily soiled)	Central spout
	Brew unit
	Area underneath the brew unit and the drip tray
	Casing
Once a month	Bean container
	Ground coffee chute and ground coffee drawer
	Water container filter (or as required)
When prompted	Milk pipework
	Degrease the brew unit (using cleaning tablets)
	Descale the machine if prompted to do so in the display

Cleaning by hand or in the dishwasher

The brew unit is **not** dishwasher safe.

Clean the brew unit by hand only under warm running water. **Do not use washing-up liquid or any other cleaning agent.**

The following components must be cleaned **by hand only**:

- Central spout stainless steel cover
- Cup sensor
- Brew unit
- Coffee bean container lid
- Lower panel

 Risk of damage as a result of excessively high dishwasher temperatures.

Components may be ruined (e.g. may become warped) if washed in a dishwasher at temperatures higher than 55 °C.

For dishwasher-safe components, always select dishwasher programmes with a maximum temperature of 55 °C.

Contact with natural dyes such as those found in carrots, tomatoes and ketchup may discolour the plastic parts in the dishwasher. This discolouration does not affect the stability of the parts.

The following components are **dishwasher safe**:

- Drip tray and lid
- Drip tray cover
- Waste container
- Water container
- Central spout (without stainless steel cover)
- Ground coffee drawer
- Milk flask with lid
- Milk siphon

Cleaning and care

 Danger of burning and scalding on hot components or by hot liquids. Components can become very hot during operation. Touching hot components can cause burning. The liquids and steam dispensed are very hot and can cause scalding. Keep well away from the area underneath the spouts when hot liquids and steam are being dispensed. Always allow the coffee machine to cool down before cleaning it. Please be aware that water in the drip tray can also be very hot.

 Risk of damage due to moisture ingress. The steam from a steam cleaning appliance could reach live electrical components and cause a short circuit. Do not use a steam cleaner to clean the coffee machine.

It is important to clean the machine regularly, as the used coffee grounds will soon go mouldy. Milk residues can go off and can block the milk pipework.

Unsuitable cleaning agents

Contact with unsuitable cleaning agents can alter or discolour the external surfaces. All surfaces are susceptible to scratching. Scratches on glass can in some circumstances lead to breakage. Remove all cleaning agent residues immediately. To protect the machine and surrounding surfaces from damage, make sure you remove any spillages or splashes of descaling agent immediately.

To avoid damaging the surfaces, do not use:

- cleaning agents containing soda, ammonia, acids or chlorides
- solvent-based cleaning agents
- cleaning agents containing descaling agents (unsuitable for cleaning the housing)
- stainless steel cleaning agents
- dishwasher cleaners (unsuitable for cleaning the housing)
- glass cleaning agents
- cleaning agents for ceramic hobs
- oven cleaner
- abrasive cleaning agents, e.g. powder cleaners and cream cleaners
- hard, abrasive brushes or sponges, e.g. pot scourers, brushes or sponges which have been previously used with abrasive cleaning agents
- melamine eraser blocks
- sharp metal scrapers
- steel wool or stainless steel wire scourers

Clean the drip tray and waste container

 **Danger of burning and scalding** on hot components or by hot liquids. Components can become very hot during operation. Touching hot components can cause burning. The liquids and steam dispensed are very hot and can cause scalding. If the pipework has just been rinsed, wait a while before removing the drip tray.

Please be aware that water in the drip tray can also be very hot. Do not touch hot components.

Clean the drip tray and waste container **every day** to avoid unpleasant smells and mildew.

The waste container is located in the drip tray. Water from rinsing also collects in the waste container.

A prompt will appear in the display when the drip tray and/or the waste container is full and needs to be emptied. Empty the drip tray **and** the waste container.

Remove the drip tray and the waste container while the coffee machine is switched on. Otherwise the message Empty the drip tray and the waste container will appear in the display even though the drip tray and/or the waste container are not filled to the maximum level.

- Pull the drip tray carefully out of the machine.

- Empty the drip tray **and** the waste container.

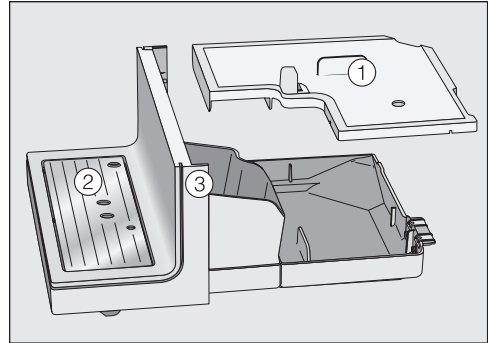

- Remove the drip tray cover ①, the drip tray ② and the lower panel ③.

Clean the lower panel by hand only using hot water, a little washing up liquid and a soft cloth. All other parts are dishwasher-safe.

- Clean all parts thoroughly.

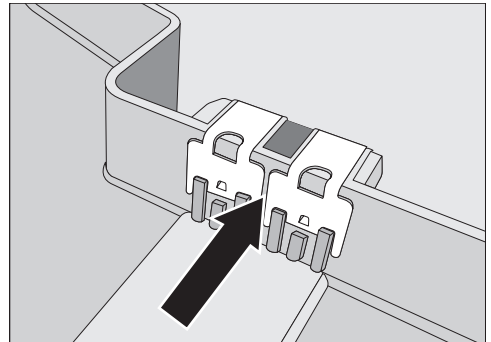

- Clean the contacts (metal discs) and the space between them carefully. Dry everything thoroughly.

The contacts will not be able to detect that the drip tray is full if they are damp or dirty. Check the contacts and the area around them once a week.

Cleaning and care

- Clean the inside of the machine underneath the drip tray.
- Replace the waste container, the lid and the lower panel **before** pushing the drip tray back into the coffee machine. Make sure the drip tray has been pushed right into the machine as far as it will go.

Cleaning the drip tray cover

- Remove the drip tray cover.
- The drip tray cover can be cleaned in the dishwasher, or by hand using warm water and a little washing-up liquid.
- Dry the drip tray.

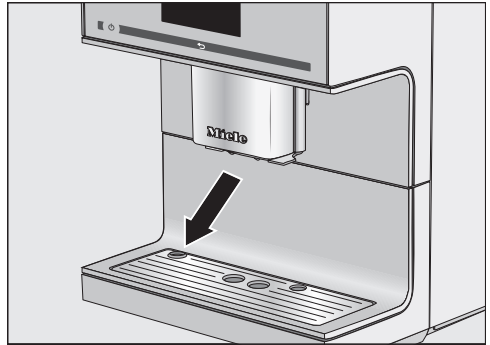

- Refit the drip tray. Make sure that the drip tray cover is correctly fitted (see picture).

Cleaning the water container

Clean the water container every day. You can clean the water container in the dishwasher once a week.

Make sure that the valve, the underside of the water container and the surface the water container sits on are clean. Otherwise, the water container will not sit correctly.

- Remove the water container.
- The water container can be cleaned in the dishwasher, or by hand using hot water and a little washing-up liquid. After cleaning, dry the water container.
- Carefully clean and dry the surface the water container sits on, taking special care to clean the recesses properly.
- Push the water container back into the appliance.

Please note that the automatic descaling programme will only work if the water container has been filled and correctly fitted in the machine.

Removing and cleaning the water container filter

Clean the water container filter once a month.

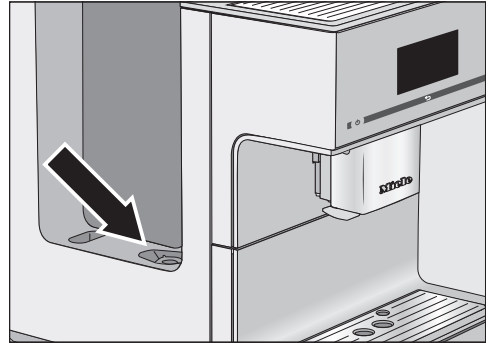

The water container filter is located under the water container.

- Open the lid on the left and remove the water container.

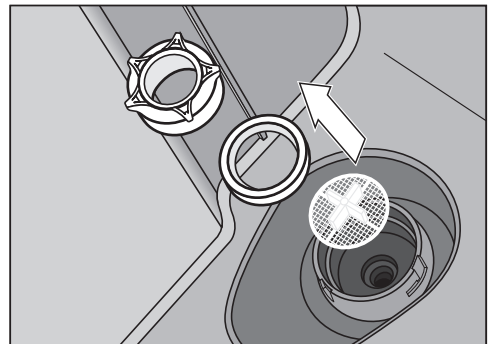

- Unscrew the cap. Remove the seal and the filter.
- Clean all parts thoroughly. Rinse all parts carefully under running water.
- Then replace the filter (with the cross facing upwards) and then the seal. The opening of the seal should face upwards. Finally screw the cap back on tightly.
- Push the water container back into the appliance.

Cleaning and care

Cleaning the central spout with integrated Cappuccinatore

With the exception of the stainless steel cover, all parts of the central spout should be cleaned in the dishwasher at least **once a week**. This will remove coffee deposits and milk residues effectively.

Clean the central spout stainless steel cover **by hand only** using warm water and a little washing-up liquid.

Start in the *Drinks* menu.

If the central spout is in the uppermost position, it cannot be dismantled. The central spout must be moved into the maintenance position to do this.

- Touch ↵ for 3 seconds.

The central spout will move into the maintenance position.

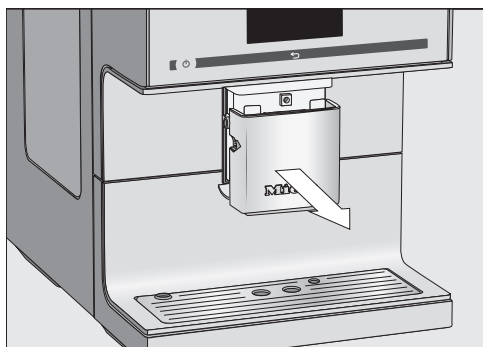

- Carefully pull the stainless steel cover off.

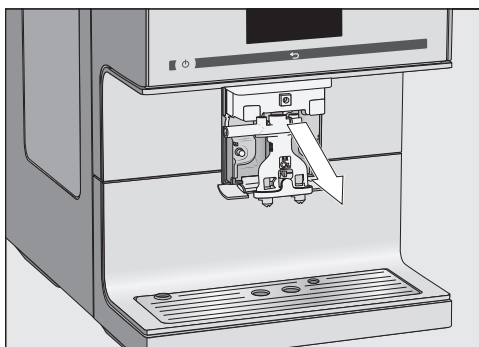

- Remove the dispensing unit to the front.

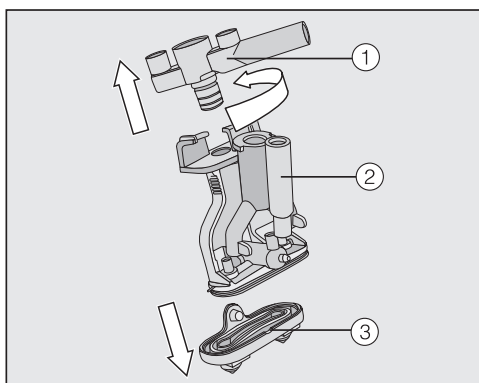

- Twist off the upper section ① with the holder for the milk pipe. Pull the component off. Then pull the Y-shaped piece ② off. Remove the dispensing spouts ③.
- Clean all parts thoroughly.

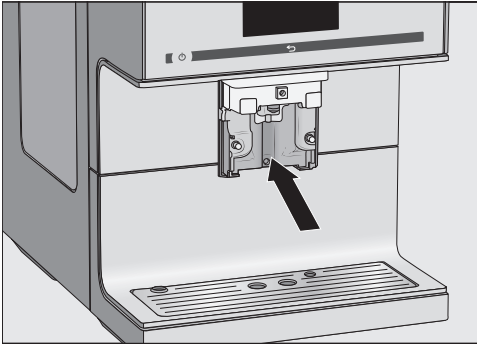

- Clean the surfaces of the central spout with a damp cloth.

Clean any blockages in the milk pipework under running water with the special brush supplied:

- Insert the brush in the pipework. Move it back and forth until all milk residue has been removed.

Reassembling the central spout

The dispensing unit is easier to reassemble if the individual parts are dampened with water beforehand.

- Fit the dispensing unit back together. Push the spouts ③ firmly back onto the dispensing unit.

Make sure that all parts are tightly connected to one another.

- Push the dispensing unit back into the central spout and replace the stainless steel cover.
- Touch *OK*.

Tip: If the coffee machine is switched off, the central spout components can be removed and cleaned at any time.

Removing and cleaning the cup sensor

The cup sensor is located under the central spout.

Clean the cup edge sensor daily by hand with warm water and a little washing-up liquid.

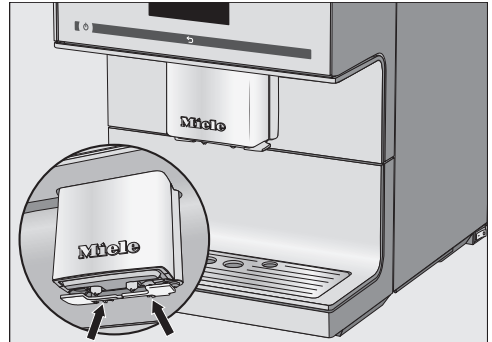

- Press the two retainers together (see arrows).

The cup edge sensor is released.

- Clean the cup edge sensor.

Refitting:

- Press the cup edge sensor from below into the holder on the central spout.

Cleaning and care

Cleaning the milk siphon

Clean the milk siphon every day.

- Rinse the milk siphon under running water.
- Remove the connecting piece from the stainless steel tube.
- Clean the individual components in a dishwasher.

Tip: Alternatively, you can soak the individual components overnight in water and washing-up liquid. Rinse the components under running water afterwards.

Cleaning the milk flask

Clean the milk flask every day in a dishwasher or by hand using warm water and a little washing-up liquid.

- Unscrew the lid from the milk flask and remove the stainless steel tube.
- Place all milk flask components in a dishwasher.

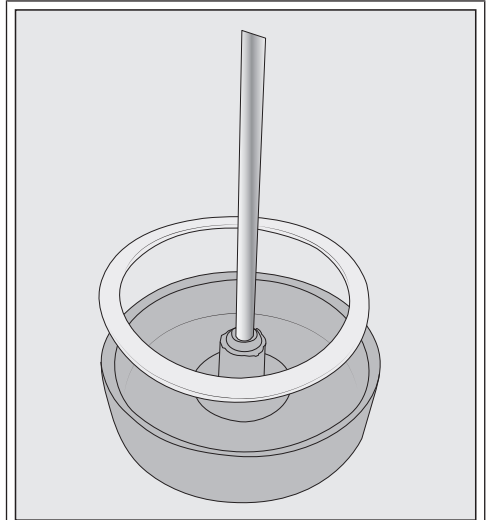

If necessary, you can remove the connecting piece and sealing ring from the milk flask lid. Once you have removed the stainless steel tube, the connecting piece is easy to push out from the inside of the lid. Clean the individual components in a dishwasher.

Cleaning the milk pipework manually or using the maintenance programme

 Risk to health due to inadequate cleaning

Milk naturally contains bacteria. Heat and moisture inside the coffee machine can cause these bacteria to multiply, e.g. milk residues can go off and pose a risk to health.

Clean all components in which milk is transported on a regular basis.

The milk pipework must be cleaned at least once a week. A message in the display will prompt you when this needs to be done.

- Confirm the message with *OK*.

When you confirm the message *Clean the milk pipework* with *OK*, the internal counter for the cleaning interval will be reset. You will **not** be reminded again.

There are two options for cleaning the milk pipework:

- You can remove and dismantle the central spout with its integrated cappuccinatore and either wash it in the dishwasher or by hand with warm water and a little washing-up liquid (see “Cleaning the central spout with integrated cappuccinatore”).
- Or you can clean the milk pipework using the *Clean the milk pipework* maintenance programme together with the Miele Cleaning agent for milk pipework (see “Cleaning the milk pipework”).

Tip: In addition to your weekly cleaning routine we recommend carrying out the alternative cleaning procedure once a month. For example if you manually clean the machine once a week, then you should run the maintenance programme once a month. This combination will ensure optimum cleaning of the milk pipework.

Cleaning the bean system

 Danger of injury on the moving grinder!

If you reach into the grinder or objects such as a spoon are left in the grinder and a grinding process is unintentionally started, you could be injured.

Switch off the machine and disconnect it from the power supply before cleaning the bean system.

Coffee beans contain oils which can deposit on the walls of the bean containers and hinder the flow of the beans. Therefore, clean the bean containers regularly with a soft cloth.

If required, you can clean the lids of the bean containers **by hand** with warm water and a little washing-up liquid. Dry the lids thoroughly before refitting them on the bean containers.

- Remove the lid of each bean container.
- Remove any coffee beans.

Tip: Use a vacuum cleaner to remove any coffee residues from the bean containers.

- Clean the bean container with a dry, soft cloth.

You cannot remove the finger protection grille.

- Refit the lids.

The bean containers can now be refilled individually.

Cleaning and care

Tip: Open one lid at a time to prevent mixing of bean types when filling the bean system.

Ground coffee drawer cleaning

Clean the ground coffee drawer and chute for ground coffee regularly, e.g. when you degrease the brew unit.

- Open the appliance door.

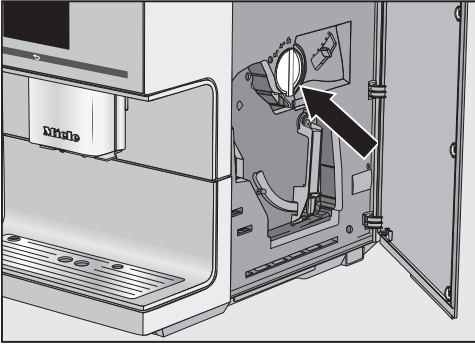

- Turn the handle (see arrow) to the left to remove the ground coffee drawer.
- The ground coffee drawer can be cleaned in the dishwasher, or by hand using hot water and a little washing-up liquid. Dry the ground coffee drawer.
- Remove any ground coffee residues from the ground coffee chute with a soft, dry cloth.
- Refit the ground coffee drawer. Turn the handle to the right to close the ground coffee chute.
- Close the appliance door.

Vacuuming out the ground coffee chute

In order to remove coffee residues properly from the grinder channel, you should vacuum out the ground coffee chute once a year with the vacuum cleaner attachment (supplied).

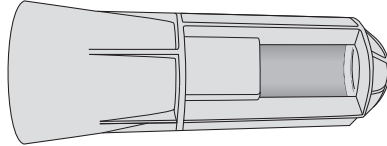

- Open the appliance door and remove the ground coffee drawer.

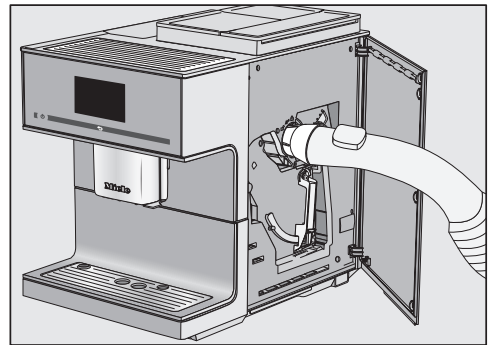

- Fit the attachment to the suction tube on your vacuum cleaner to vacuum out the ground coffee chute.
- Remove the attachment and refit the ground coffee drawer.
- Close the appliance door.

Cleaning the casing

If soiling is allowed to stay on for a long time or there is contact with unsuitable cleaning agents, surfaces can alter or discolour.

Remove any soiling immediately.

Ensure that any splashes of descaler are wiped up immediately.

- Switch the coffee machine off.
- Clean the appliance front with a clean soft sponge and a solution of warm water and washing-up liquid. Then wipe it all dry using a soft cloth.

Tip: You can also clean the appliance casing with the Miele all purpose microfibre cloth.

Maintenance programmes

The coffee machine has the following maintenance programmes:

- Rinsing the machine
- Rinsing the milk pipework
- Cleaning the milk line
- Degreasing the brew unit
- Descaling the machine

Carry out the relevant maintenance programme when the prompt to do so appears in the display. You can also start maintenance programmes at any time so that the coffee machine does not prompt mandatory cleaning at an inconvenient time.

Please note that each maintenance programme must be carried through to the end and cannot be cancelled.

Opening the “Maintenance” menu

Start in the *Drinks* menu.

- Touch ↶.
- Select *Maintenance*.

You can now select a maintenance programme.

Cleaning and care

Rinsing the machine

After a coffee has been dispensed, the machine is rinsed before it switches off. This removes any residual coffee.

You can also rinse the milk pipework manually.

Start in the **Drinks** menu.

- Touch **↶**.
- Select **Maintenance and then Rinse the machine**.

You may also be prompted to insert the end of the milk tube into the drip tray.

Rinsing the milk pipework

The milk pipework can become blocked by milk residues. The milk pipework should therefore be rinsed regularly. If a drink has been made using milk, the prompt to place the milk pipework into the drip tray will appear at the latest when you switch the machine off.

You can also rinse the milk pipework manually.

Start in the **Drinks** menu.

Tip: Place a suitable container underneath the central spout.

- Touch **↶**.
- Select **Maintenance and then Rinse the milk pipework**.

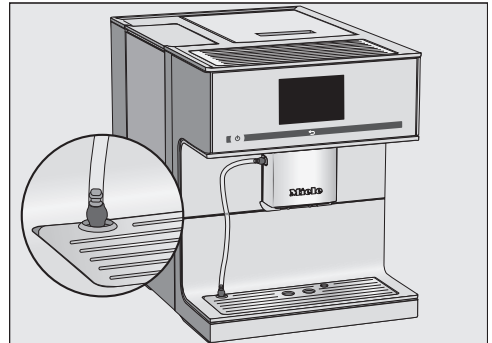

- Place the end of the milk tube into the aperture in the drip tray cover.
- Confirm with **OK**.

The milk pipework will now be rinsed.

Cleaning the milk pipework

For optimal cleaning results, we recommend using the Miele cleaning agent for milk pipework. The cleaning agent for milk pipework has been specially developed for use with Miele coffee machines and prevents subsequent damage.

It is available to order via the Miele webshop, the Miele Customer Service Department (see the end of this booklet for contact details) or from your Miele dealer.

The Clean the milk pipework maintenance programme lasts for approx. 10 minutes.

You need 1 stick of cleaning agent for milk pipework to clean it.

Start in the Drinks menu.

- Touch ↶.

The cleaning process cannot be cancelled. It must be completed through to the end.

- Select Maintenance and then Clean the milk pipework.

The process will start.

- Follow the instructions in the display.

Insert milk pipe in cleaning agent will appear in the display.

Preparing the cleaning solution:

- Dissolve the cleaning agent in a container with 200 ml of lukewarm water. Stir the solution with a spoon until the powder has fully dissolved.

Carrying out the cleaning process:

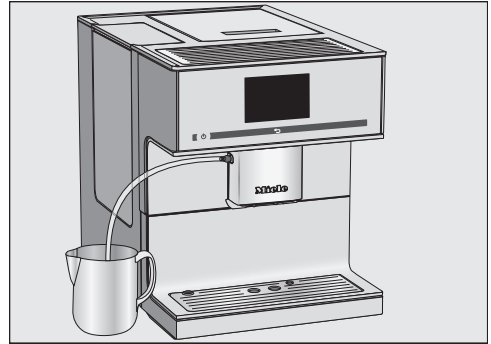

- Place the container next to the coffee machine and hang the milk pipe in the solution. Make sure the milk pipe is placed sufficiently far into the cleaning solution.
- Touch OK.
- Follow the further instructions given in the display.

The cleaning process is finished at the end of the rinsing cycle.

Cleaning and care

Degreasing the brew unit and cleaning the interior

Depending on the natural oil content of the coffee used, the brew unit can become blocked quite quickly. It must be degreased regularly in order to ensure aromatic coffee and trouble-free operation of the coffee machine.

We recommend using Miele cleaning tablets to clean the brew unit. These have been specially developed for degreasing the brew unit in Miele coffee machines and prevent subsequent damage.

The cleaning tablets are available to order via the Miele webshop, the Miele Customer Service Department (see the end of this booklet for contact details) or from your Miele dealer.

The maintenance programme for degreasing the brew unit lasts for approx. 10 minutes.

You need 1 cleaning tablet for the maintenance programme.

After 200 portions have been dispensed, **Degrease the brew unit** will appear in the display.

- Confirm the message with **OK**.

The message will appear at regular intervals. Once the maximum possible number of portions has been reached, the coffee machine will lock out.

You can switch the coffee machine off if you do not want to carry out the maintenance programme at this point in time. You will only be able to make coffee drinks again once the brew unit has been degreased.

Degrease the brew unit when prompted to do so.

No drinks can be made and **Degrease the brew unit** appears in the display.

The maintenance programme cannot be cancelled. It must be completed through to the end.

- Touch **OK**.

The maintenance programme will then start.

- Follow the instructions in the display.

Cleaning the brew unit and interior

To ensure good tasting coffee and to prevent the formation of microbes in the machine, remove and clean the brew unit under running water once a week.

The moving parts of the brew unit are lubricated. Cleaning agents and washing-up liquid will damage the brew unit.

Clean the brew unit by hand only under warm running water. **Do not use washing-up liquid or any other cleaning agent.**

- Open the appliance door.

Cleaning and care

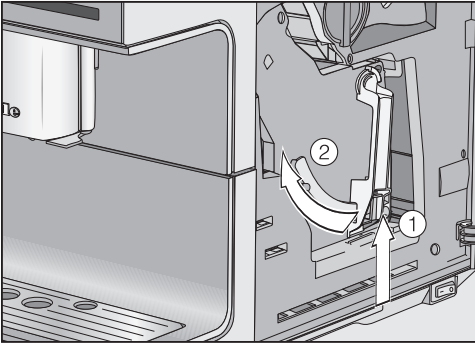

- Dry the funnel to prevent ground coffee sticking to it the next time a coffee is made.

⚠ Risk to health due to inadequate cleaning

Damp coffee residues in the interior of the machine can go mouldy and pose a risk to health.

Remove coffee residues regularly and clean the interior of the machine.

- Press and hold the button under the brew unit handle (1) and, whilst doing so, turn the handle to the left (2).
- Carefully pull the brew unit out of the coffee machine.

When you have removed the brew unit, do **not** change the position of the handle on the brew unit. Otherwise the brew unit cannot be inserted.

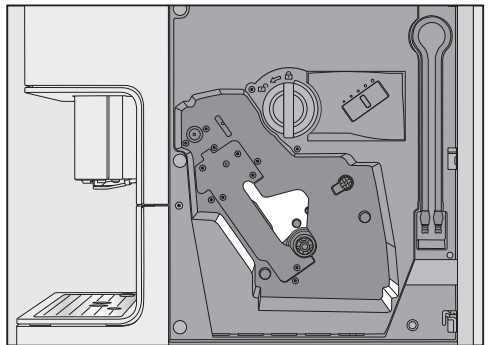

- Clean the brew unit **by hand under warm running water** without using cleaning agent or washing-up liquid.

- Clean the inside of the coffee machine. Make sure that the areas highlighted in the illustration are cleaned especially well.

Tip: Use your vacuum cleaner to remove dry ground coffee residues.

The following will appear in the display:
Fit the brew unit with a cleaning tablet in it.

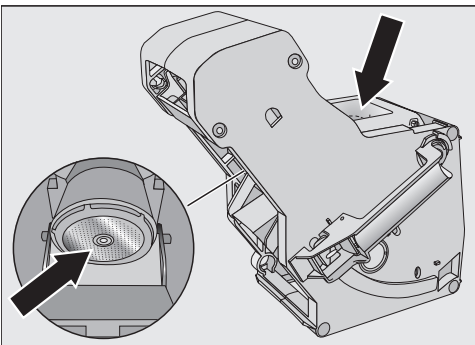

- Wipe any remaining coffee off the two filters (see arrows).

Cleaning and care

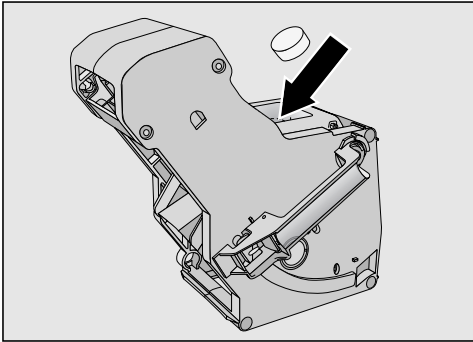

- Drop a cleaning tablet into the top of the brew unit (arrow).
- Push the brew unit with cleaning tablet back into the coffee machine, making sure it goes in straight.

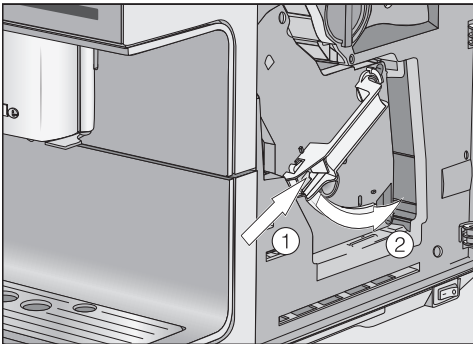

- Press the button under the handle of the brew unit ① and, whilst doing so, turn the handle to the right ②.
- Close the appliance door.
- Follow the further instructions given in the display.

The cleaning process is finished at the end of the rinsing cycle.

Descaling the machine

Risk of damage from spilt descaling solution.

Sensitive surfaces and/or natural floors can suffer damage.

Wipe up any spillages of descaling agent immediately.

Limescale builds up in the coffee machine through use. How often the appliance needs to be descaled will depend on the water hardness level in your area. Limescale must be removed regularly.

Depending on how you use your machine and the water hardness level in your area, occasionally you will need to descale your machine manually in addition to automatic descaling.

If a descaling cartridge is **not** fitted, an **empty** cartridge is fitted or an **expired** cartridge is fitted, the machine needs to be descaled regularly using the **Descal** the machine maintenance programme.

The appliance will guide you through the descaling process. Various messages will appear in the display, e.g. you will be prompted to empty the drip tray or fill the water container.

You need **1** descaling tablet for the descaling process. The process takes approx. 12 minutes.

The coffee machine prompts you when it needs to be descaled. Number of drinks until the machine must be descaled: **50** will appear in the display. The remaining

number of drinks that can be made before descaling will show in the display after each drink.

- Confirm the message with **OK**.

When the number of remaining portions reaches 0, the coffee machine will lock out.

Descal the machine will appear in the display.

You can switch the coffee machine off if you do not want to carry out the descaling programme at this point in time. You can not make any drinks until the machine has been descaled.

Descaling after prompt appears in the display

Descal the machine appears in the display.

Descaling cannot be cancelled once it has started. It must be completed through to the end.

- Touch **OK**.

The process will start.

- Follow the instructions in the display.

When Fill the water container to the  symbol with descaling agent and lukewarm water and place it in the machine. **appears** in the display, proceed as follows.

Preparing the descaling solution

For optimum descaling results, we recommend using the Miele descaling tablets provided.

The descaling tablets have been specially developed for Miele coffee machines.

Other descalers, which contain other acids besides citric acid and/or other undesirable substances, such as chlorides for example, can cause damage to the product. Moreover, the descaling result required cannot be guaranteed if the descaling solution was not of the appropriate concentration.

Miele descaling tablets are available to order via the Miele webshop, from the Miele Customer Service Department (see the end of this booklet for contact details) or from your Miele dealer.

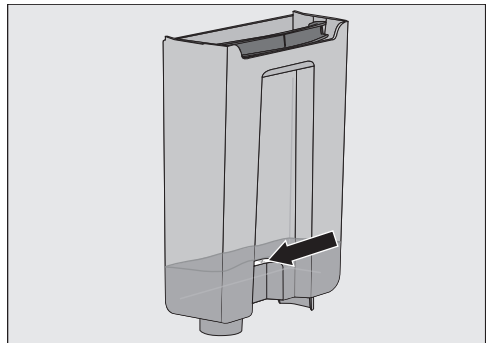

- Fill the water container to the descaling symbol  with lukewarm water.
- Place **1** descaling tablet in the water.

Follow the instructions for the mixing ratio carefully. It is important to fill the water container with the correct amount of water. Otherwise the descaling process will be cancelled prematurely.

Carrying out descaling

- Push the water container back into the appliance.

Cleaning and care

- Follow the further instructions given in the display.

When Rinse the water container and fill it to the  symbol with fresh tap water **appears** in the display:

- Remove the water container and rinse it thoroughly with clean water. Ensure that **no** descaling solution residue remains in the water container. Fill the water container to the descaling symbol  with fresh tap water.

The descaling process is complete at the end of the rinsing process. You can now make drinks again.

Risk of damage from spilt descaling solution.

Sensitive surfaces and/or natural floors can suffer damage.

Wipe up any spillages of descaling agent.

When handling a cartridge which has already been filled with water, ensure that the descaling solution does not come into contact with sensitive surfaces.

To ensure the longevity of components and a consistent environment free of limescale, the coffee machine needs to be manually descaled from time to time. The intervals are determined by your usage behaviour and the water hardness level of your area. If you make a lot of coffees with milk, for example, you will need to descale the coffee machine more frequently with the descaling tablets.

The coffee machine has an automatic maintenance programme for descaling the machine. For automatic descaling, a Miele descaling cartridge is fitted at the back of the coffee machine. The coffee machine will automatically determine the days when to carry out automatic descaling based on the usage pattern. Automatic descaling takes approx. 4 hours, including the activation time.

You can set the time for automatic descaling to start using the [Descaling timer](#).

Water is mixed with the descaling agent to create a solution for automatic descaling. This descaling solution is then pumped through the pipework of the coffee machine. After the activation time, the solution is then rinsed out of the pipework and the machine can then be used as normal for making drinks.

During automatic descaling you will hear pumping and rinsing noises at frequent intervals even though the appliance is switched off and the display is dark.

If you do not make any drinks, automatic descaling will not be started.

Please note before and during automatic descaling:

The coffee machine must be ready to use and the following conditions must be met:

- A descaling cartridge which is ready to use is fitted.
- The coffee machine is connected to the electricity supply. The coffee machine must **not** be disconnected from the electricity supply during automatic descaling.
- The drip tray, brew unit and central spout are inserted.
- The water container is inserted and is filled with water at least up to the  descaling mark.
- Carry out the instructions which appear in the display before switching off, e.g. Empty the drip tray.
- The milk pipe is inserted into the aperture in the drip tray.
- The coffee machine is switched off.

Automatic descaling

The Miele descaling cartridge

Only use the Miele descaling cartridge for the automatic descaling programme.

Please note that the Miele descaling cartridge has a lifespan of approx. one year after it has been placed in the machine and filled with water for the first time. Critical for the one-year shelf life is the date on which the descaling cartridge was fitted and filled with water.

Do not fit a descaling cartridge which has already been used in another Miele coffee machine. Your coffee machine will have no information about the fill level of this cartridge. The descaling effect may be insufficient and damage your coffee machine.

Do not fill the descaling cartridge with other fluids or substances.

The descaling agent comes in the form of tablets in the descaling cartridge. The cartridge is filled with water when it is placed in the machine. The tablets gradually dissolve over time.

The Miele descaling cartridge will last for 7 to 12 months of automatic descaling, depending on how often the coffee machine is used.

A prompt will appear in the display shortly before the cartridge is depleted, reminding you that it needs to be replaced. Confirm the message with *OK*. After this first message, six more descaling programmes are possible.

The descaling cartridge is available to order from the Miele online shop or directly from Miele (see back cover for contact details).

If a descaling cartridge is **not** fitted, an **empty** cartridge is fitted or an **expired** cartridge is fitted, the machine needs to be descaled using the *Descal the machine* maintenance programme. To do this, the appropriate descaling agent is required (see “Cleaning and care - Descaling the machine”).

The descaling cartridge can remain fitted even if the machine is not used for a long time. Remove the cartridge before transporting the coffee machine. Please note:

- Once filled with water, the descaling cartridge has a maximum shelf life of three weeks outside of the machine.
- It should be transported with care and upright. Avoid shaking it. Shaking or turning upside down reduces the shelf life or damages the cartridge.
- The cartridge should be stored upright, in a dark place and at room temperature (16 - 38 °C).

Fitting and removing a descaling cartridge

Risk of damage from spilt descaling solution.

Sensitive surfaces and/or natural floors can suffer damage.

When handling a cartridge which has already been filled with water, ensure that the descaling solution does not come into contact with sensitive surfaces.

The coffee machine is switched on. Only then will the appliance detect the descaling cartridge.

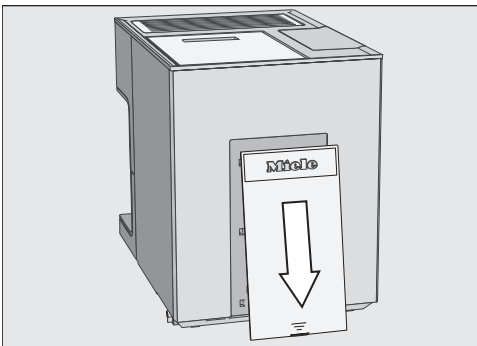

- Slide the cover at the back of the coffee machine downwards.

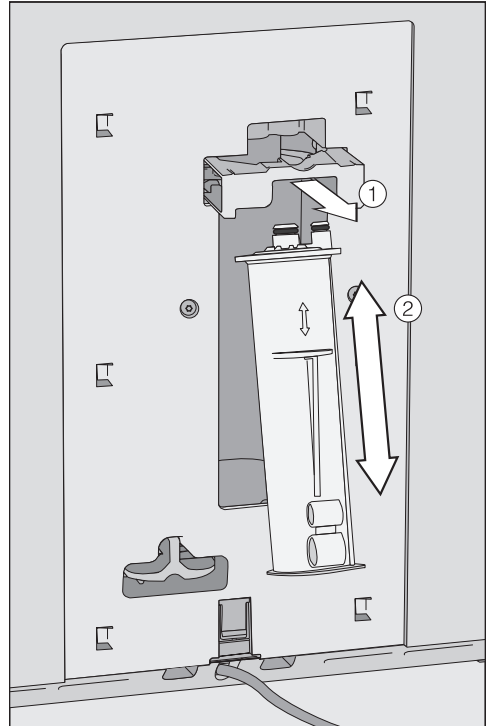

- Pull the cartridge holder ① forwards. There is already a cartridge fitted.
- Remove the cartridge ②.

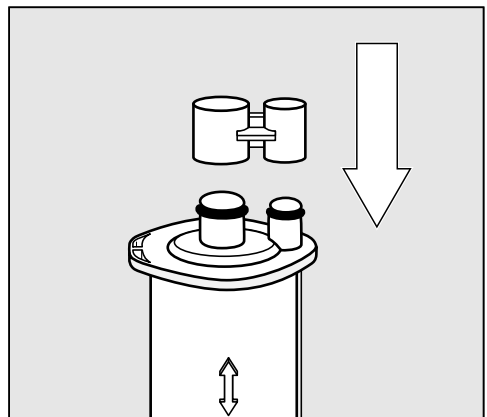

- Seal the cartridge with the cap.

Automatic descaling

The cap is located on the cartridge. Release it by snapping it off.

- Dispose of the spent cartridge with your household waste.

Fit the descaling cartridge

- Insert the cartridge ② and push it upwards as far as it will go.
- Push the cartridge holder ① back and then close the cover.
- Follow the instructions in the display.

The next time the coffee machine is switched off, the descaling cartridge will also fill with water when the machine is rinsed. You will hear water being pumped into the cartridge at frequent intervals.

If you do not want to fit a descaling cartridge, the system must be sealed with the plug. Messages such as “Fit a new descaling cartridge” will be not displayed.

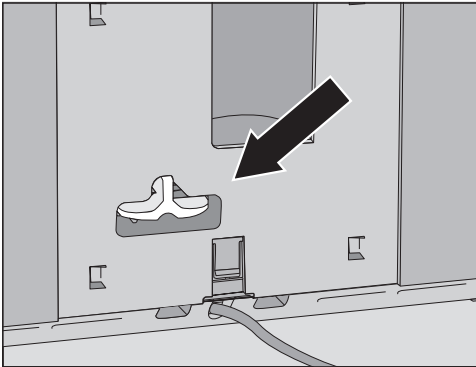

- Insert the adapter in place of the cartridge.

Set the start time for automatic descaling (Descaling timer)

You can set the daily start time for automatic descaling as you wish. The coffee machine must be switched off for the duration of the activation phase (approx. 4 hours).

Start in the Drinks menu.

- Touch ↶.
- Select Settings  and then Timer.
- Select Descaling timer.
- Set the start time you want and touch OK.

The start time is saved. From now on automatic descaling will commence at the desired time each day.

Cancelling automatic descaling

You can cancel automatic descaling during the activation phase.

Automatic descaling can be cancelled as often as you like. You would then need to descale the coffee machine using the descaling tablets (see “Cleaning and care - Descaling the appliance”).

- Touch the On/Off sensor ①.

The time left in hours is shown in the display.

- Touch Cancel.

The descaling solution is rinsed out of the pipework. Rinsing can take up to 5 minutes. You can make drinks afterwards.

Switching off automatic descaling

If you remove the descaling cartridge, automatic descaling is deactivated. You will then descale manually using the **Descal the machine maintenance programme**. To do this, the appropriate descaling agent is required (see “Cleaning and care - Descaling the machine”).

- Remove the descaling cartridge and seal the system with the adapter.

Problem solving guide

Many malfunctions and faults that can occur in daily operation can be easily remedied. Time and money will be saved because a service call will not be needed.

The following guide may help you to find the reason for a malfunction or a fault, and to correct it.

Messages in the display

Error messages must be confirmed with *OK*, otherwise the message can reappear in the display even though the problem has been remedied.

Follow the instructions which appear in the display to remedy the problem.

If after this, the fault message appears in the display again, contact Miele Service.

Problem	Cause and remedy
F1, F2, F80, F82	There is an internal fault. ■ Switch the coffee machine off with the On/Off sensor ①. Wait for approx. 1 hour before switching it back on again.
F41, F42, F74, F77, F225, F226, F235, F236	There is an internal fault. ■ Switch the machine off with the On/Off sensor ①. Wait for approx. 2 minutes before switching it back on again.

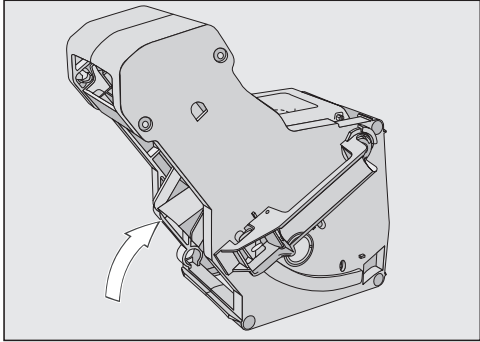
Problem	Cause and remedy
<p>F73 or Check the brew unit</p>	<p>The brew unit cannot be positioned correctly.</p> <ul style="list-style-type: none">■ Switch the machine off with the On/Off ⓪ sensor.■ Remove the brew unit and clean it by hand.  <ul style="list-style-type: none">■ Push the coffee ejector of the brew unit into the correct position.■ Do not fit the brew unit. Close the service panel and switch the coffee machine on with the On/Off ⓪ sensor. <p>This will initialise the brew unit motor and put it back into the start position.</p> <ul style="list-style-type: none">■ When Insert the brew unit appears in the display, put the brew unit back in the machine. Close the appliance door. <p>If the message appears again, reduce the amount of coffee and/or select a finer grinder setting. Some types of coffee have a much higher grinding volume.</p>

Problem solving guide

Problem	Cause and remedy
F233	<p>The cup sensor is not inserted or is incorrectly inserted.</p> <p>The stainless steel cover of the central spout was not fitted properly, e.g. is tilting forwards slightly.</p> <p>If the central spout is moving upwards and the cup sensor is bumped, e.g. with a cup, the cup sensor loses its reference position.</p> <ul style="list-style-type: none">■ Confirm the message with <i>OK</i>.■ Switch the machine off with the On/Off ① sensor. Wait for at least 30 minutes before switching the machine back on again. Or disconnect the appliance from the electricity supply by switching off at the wall socket and withdrawing the power plug, or switching off the mains circuit breaker.■ Refit the cup sensor.■ Refit the stainless steel cover. Make sure the cover is seated correctly.
F 355, F 357– F 362	<p>The bean system must be set up again, e.g. coffee beans have possibly got jammed.</p> <ul style="list-style-type: none">■ Switch the machine off with the On/Off ① sensor. Wait for 30 minutes before switching the machine back on again.

Unusual performance of the coffee machine

Problem	Cause and remedy
The lighting remains off after the coffee machine has been switched on.	The lighting has been switched off. ■ Switch the lighting on (see “Settings - Lighting”).
	The lighting is faulty. ■ Call Service.
The display remains dark when the coffee machine is turned on using the On/Off button ①.	The On/Off button ① was not held for long enough. ■ Touch and hold the On/Off ① sensor for at least three seconds.
	The plug is not inserted in the socket correctly. ■ Insert the plug into the socket.
	The fuse has tripped because the coffee machine, voltage, or another appliance is defective. ■ Switch off at the wall socket and remove the plug. ■ Contact a qualified electrician or Miele.
The coffee machine turns off suddenly.	The factory set switch-off time (20 minutes) or the switch-off time you have programmed has been reached. ■ If required, you can select a new switch-off time (see “Settings – Timer”).
	The plug is not inserted in the socket correctly. ■ Insert the plug into the socket.
The coffee machine is switched on. The lighting switches off suddenly.	The lighting switches off automatically if the coffee machine has not been used for some time. The automatic switch-off time cannot be changed.
The sensors do not react to touch. The coffee machine cannot be operated.	There is an internal fault. ■ Disconnect the machine from the power supply by removing the plug from the socket.

Problem solving guide

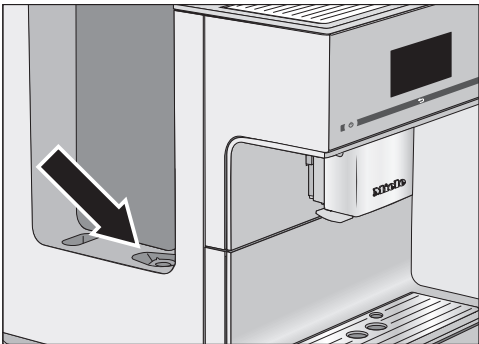
Problem	Cause and remedy
<p>The coffee machine does not switch itself on, although the <small>Switch on at</small> setting has been activated for the timer.</p>	<p>The system lock has been activated.</p> <ul style="list-style-type: none"> ■ Deactivate the system lock. <p>A day of the week has not been selected and/or the timer has not been activated.</p> <ul style="list-style-type: none"> ■ Check and change the timer settings. <p>The coffee machine was not used after being switched on automatically three times in succession (holiday mode).</p> <ul style="list-style-type: none"> ■ Switch the machine on and dispense a drink. <p>The coffee machine does not switch on with the <small>Switch on at timer</small> while automatic descaling is being carried out. This is not a fault. Select a different timer setting.</p>
<p>Fill and refill the water container appears in the display even though the water container is full and in the machine.</p>	<p>The water container is not in the correct position.</p> <ul style="list-style-type: none"> ■ Remove the water container and push it back in again. ■ Clean the surface underneath the water container if necessary. <p>During the <small>Descalate</small> the machine maintenance programme the water container was not correctly filled and refitted.</p> <ul style="list-style-type: none"> ■ Fill the water container to the descaling symbol  and restart the descaling programme. <p>The water container filter is blocked.</p>  <ul style="list-style-type: none"> ■ Clean the water container filter (see “Cleaning and care - Removing and cleaning the water container filter”).

Problem solving guide

Problem	Cause and remedy
<p>Fill and refit the water container appears after switching on even though the container is filled and fitted in the machine. The appliance does not rinse.</p>	<p>The descaling cartridge is not fitted. The coffee machine needs descaling.</p> <ul style="list-style-type: none">■ Switch the machine off with the On/Off ① sensor. Wait approx. one hour.■ Switch the appliance back on again. As soon as Heating-up phase appears, touch Mainten. and then select Descale the machine.■ Descale the coffee machine.
<p>The bean containers are empty and the message Fill the bean container does not appear.</p>	<p>The fill level sensors in the bean containers are dirty.</p> <ul style="list-style-type: none">■ Remove the coffee beans from the bean containers, e.g. with a vacuum cleaner. <div data-bbox="400 587 878 927" data-label="Image">An illustration showing the internal structure of the bean containers. It depicts two bean containers on top and a central compartment below. Three arrows point to small, light-colored sensor components: one on the left side of the top-left container, one on the right side of the top-right container, and one in the center of the bottom compartment.</div> <ul style="list-style-type: none">■ Clean the fill level sensors (see illustration) with a soft, dry cloth.
<p>Insert the drip tray and the waste container appears in the display, even though both have been inserted.</p> <p>Although the drip tray has been emptied, Empty the drip tray and the waste container appears in the display.</p>	<p>The drip tray is not in the correct position and is therefore not detected.</p> <ul style="list-style-type: none">■ Empty the drip tray and the waste container if necessary.■ Reassemble all parts and push the drip tray back in the coffee machine until it clicks.

Problem solving guide



Problem	Cause and remedy
<p>The waste container is overflowing even though the drip tray and waste container have been emptied following each reminder.</p>	<p>The drip tray has probably been removed without the waste container being emptied. Removing the drip tray resets the internal counter for emptying the waste container.</p> <ul style="list-style-type: none"> ■ Always empty the waste container if you remove the drip tray. <hr/> <p>Certain types of beans produce a lot of coffee when they are ground, meaning that larger coffee pucks are pressed.</p> <ul style="list-style-type: none"> ■ Adapt the quantity of coffee and grinder setting if necessary. ■ Empty the waste container more often than indicated in the display.
<p>The brew unit cannot be removed.</p>	<p>The brew unit is not in the correct position because the appliance door was opened during the brewing process, for example.</p> <ul style="list-style-type: none"> ■ If necessary, move the handle on the brew unit back to the start position. Close the appliance door. ■ Switch the machine off with the On/Off ① sensor. ■ Disconnect the coffee machine from the power supply. ■ Wait approx. one minute before reconnecting the coffee machine to the electricity supply and switching it on. <p>This will initialise the brew unit motor and put it back into the start position.</p> <ul style="list-style-type: none"> ■ If necessary, repeat these steps.
<p>Coffee is not flowing out of the central spout. Or coffee is only being dispensed via one spout.</p>	<p>The central spout has a blockage.</p> <ul style="list-style-type: none"> ■ Rinse the coffee pipework (see “Cleaning and care - Rinsing the machine”). <p>If there is still no coffee coming out, or coffee is only coming out of one side</p> <ul style="list-style-type: none"> ■ Dismantle the central spout and clean all parts carefully. ■ Make sure all parts are reassembled correctly.

Problem solving guide

Problem	Cause and remedy
Neither milk nor milk froth comes out of the central spout.	The milk pipework is blocked. ■ Clean the central spout and milk pipework carefully with the brush.
A fan can be heard even though no drinks are being prepared or the coffee machine is switched off.	This is not a fault. Once a drink has been dispensed or the machine has been switched off, the internal fan will continue to run until the interior is sufficiently dehumidified.
The display lights up but the coffee machine does not heat up and no drinks are made. The coffee machine cannot be turned off.	The Demo mode for demonstrating the coffee machine in the showroom has been activated. ■ Deactivate Demo mode.

Problem solving guide

Faults with automatic descaling

Problem	Cause and remedy
After switching on, a message appears informing you that automatic descaling could not be carried out.	<p>If you have made drinks with milk, the milk tube must be pushed into the drip tray and when the machine is switched off, the message about this in the display confirmed with <i>OK</i>.</p> <p>All removable parts, such as the water container, drip tray, brew unit or central spout must be fitted.</p> <p>The water container must be filled with water at least up to the descaling symbol .</p> <p>The machine door was not closed.</p> <ul style="list-style-type: none">■ Confirm the message with <i>OK</i>.■ Make sure that the coffee machine is ready to use before the next descaling process. <hr/> <p>The coffee machine was not switched off at the start time using the On/Off  sensor.</p> <p>The coffee machine pipework will only be filled with descaling solution when the coffee machine is switched off.</p> <ul style="list-style-type: none">■ Confirm the message with <i>OK</i>.■ Change the start time if necessary.
Descalce appliance manually appears in the display even though a descaling cartridge which is ready to use is fitted. Drinks cannot be made.	<p>Depending on the water hardness level in your area and your usage behaviour, the coffee machine needs to be descaled using the maintenance programme occasionally.</p> <p>For this you will need to use Miele descaling tablets.</p> <ul style="list-style-type: none">■ Descalce the coffee machine using the maintenance programme (see “Cleaning and care - Descaling the appliance”).

Unsatisfactory results

Problem	Cause and remedy
<p>The coffee is not hot enough.</p>	<p>The cup has not been pre-heated. The smaller the cup and the thicker its sides, the more important it is to pre-heat it.</p> <ul style="list-style-type: none"> ■ Pre-heat the cups, e.g. using the cup heating (depending on model).
	<p>The brewing temperature has been set too low.</p> <ul style="list-style-type: none"> ■ Set a higher brewing temperature.
	<p>The filters in the brew unit are blocked.</p> <ul style="list-style-type: none"> ■ Remove the brew unit and clean it by hand. ■ Degrease the brew unit.
<p>Drinks are being dispensed from the central spout considerably more slowly. The heating-up time is getting longer and the coffee machine is not performing properly.</p>	<p>The coffee machine needs descaling. If you use hard water (> 20 °dH / 3.6 mmol/l) or if the coffee machine is used intensively, it may be necessary to descale the machine manually more frequently.</p> <ul style="list-style-type: none"> ■ Run the Descal the machine maintenance programme. You will need one descaling tablet.
<p>The consistency of the milk froth is unsatisfactory.</p>	<p>The milk temperature is too high. Good milk froth can only be achieved with cold milk (below 10 °C).</p> <ul style="list-style-type: none"> ■ Check the temperature of the milk in the milk flask.
	<p>The milk pipework is blocked.</p> <ul style="list-style-type: none"> ■ Clean the central spout and milk pipework with the brush.
<p>The coffee grinder makes a louder noise than usual.</p>	<p>The coffee bean container has become empty during the grinding process.</p> <ul style="list-style-type: none"> ■ Fill the coffee bean container with fresh beans.
	<p>There may be foreign objects such as plastic or stones in amongst the coffee beans.</p> <ul style="list-style-type: none"> ■ Switch the coffee machine off immediately. Call Service.

Problem solving guide

Problem	Cause and remedy
<p>There is no crema on the coffee or espresso.</p>	<p>The coffee beans are no longer fresh. If roasted coffee beans are stored open for too long, the carbon dioxide gradually escapes from the coffee beans. The crema is no longer formed during dispensing.</p> <p>Of course, you can still use the coffee beans.</p>
<p>The coffee tastes weak. The coffee grounds in the waste container are sludgy and grainy.</p>	<p>Insufficient coffee beans are getting into the grinder and less coffee is being brewed. Have you used a dark roast?</p> <p>This type of coffee bean is often more oily. These oils can cling to the inside of the coffee bean containers and hinder the flow of beans.</p> <ul style="list-style-type: none"> ■ Make a coffee and observe whether the coffee beans drop into the coffee bean container. ■ Clean the coffee bean containers more often if you are using darker, more oily coffee beans. <p>Try other types of coffee bean which are less oily.</p> <p>Insufficient coffee beans are getting into the grinder and less coffee is being brewed. Are you using a coffee blend with very large beans or different sized beans? The beans are possibly getting wedged or jammed and forming “bean bridges”.</p> <div style="border: 1px solid gray; padding: 5px; margin: 5px 0;"> <p> Danger of injury on the moving grinder! If you place a spoon or similar, or even fingers, in the bean containers during grinding, you could be injured. Do not reach into the bean system during grinding. Do not place any objects in the bean containers during grinding.</p> </div> <ul style="list-style-type: none"> ■ Place a narrow spoon or similar in the bean containers and stir the coffee beans. <p>The ground coffee chute is blocked.</p> <ul style="list-style-type: none"> ■ Vacuum out the ground coffee chute using the attachment supplied.

Contact in the event of a fault

In the event of any faults which you cannot remedy yourself, please contact your Miele dealer or the Miele Customer Service Department.

You can book a Miele Customer Service Department call-out online at www.miele.com/service.

Contact information for the Miele Customer Service Department can be found at the end of this document.

Please quote the model identifier and serial number of your appliance (Fabr./SN/Nr.) when contacting the Miele Customer Service Department. This information can be found on the data plate.

Please note that telephone calls may be monitored and recorded for training purposes and that a call-out charge will be applied to service visits where the problem could have been resolved as described in this booklet.

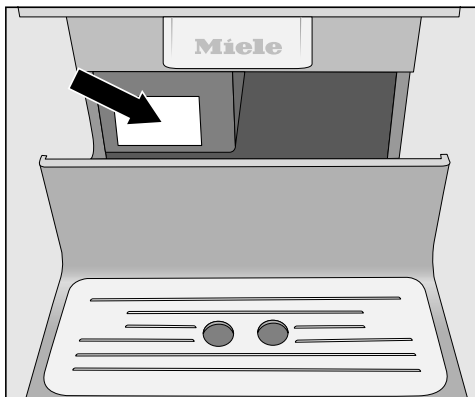

Warranty

For information on the appliance warranty specific to your country please contact Miele. See back cover for address.

In the UK, your appliance warranty is valid for 2 years from the date of purchase. However, you must activate your cover by calling 0330 160 6640 or registering online at www.miele.co.uk.

Transporting the machine

If you are not going to use the coffee machine for an extended period of time, e.g. whilst on holiday, or if it needs to be moved, a number of procedures will need be carried out to ensure its safety.

- Empty and clean the coffee bean container
- Empty and clean the water container
- Evaporate the coffee machine
- Remove the descaling cartridge and insert the adapter.
- Vacuum out the ground coffee chute using the attachment
- Clean the inside of the machine
- Pack the machine securely

Evaporate

The coffee machine pipework should be evaporated before it is stored for a long period of time or transported any distance - particularly at temperatures below freezing.

Evaporating the machine involves removing all traces of water from the system to prevent the risk of water and frost damage.

Start in the **Drinks** menu.

⚠ Danger of burning and scalding on the dispensing spouts.
Hot steam can cause scalding.
Keep well away from the area underneath the spouts when hot liquids or steam are being dispensed.
Do not touch hot components.

- Touch ↩.

- Select **Settings** and then **Service**.
- Select **Evaporate** and then **Yes**.
- Follow the instructions in the display.

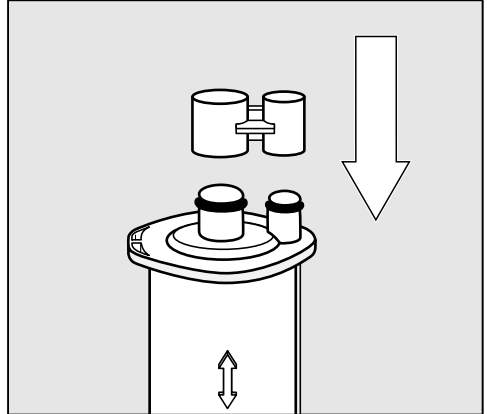

- Remove the descaling cartridge and seal it with the cap.

Once filled with water, the descaling cartridge has a max. shelf life of three weeks outside of the machine. The cartridge should be stored upright, in a dark place and at room temperature (16 - 38 °C).

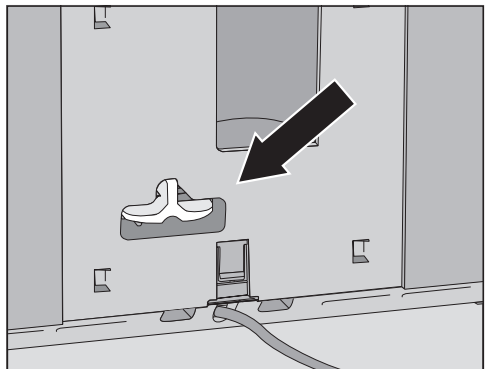

- Insert the adapter in place of the cartridge.

Transporting the machine

When the display goes out, the machine has finished evaporating.

- Clean the drip tray and waste container.

Vacuuming out the ground coffee chute using the attachment and cleaning the interior

To ensure coffee residues are removed thoroughly, you should vacuum out the ground coffee chute before transporting and clean out the interior of the machine carefully.

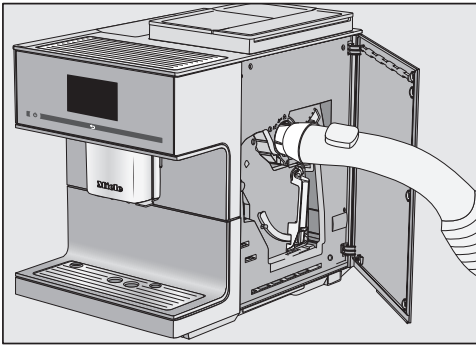

- Insert the attachment supplied and use the suction tube of your vacuum cleaner to vacuum out the ground coffee chute.
- Remove the brew unit and clean the interior of the machine.

Tip: You can also use your vacuum cleaner to remove any dry ground coffee residues.

- Clean the brew unit before refitting it.

Packing the machine

The coffee machine should only be packed when it is clean and dry. Residues of coffee grounds can cause scratches on surfaces. Coffee and milk residues or water can cause a build-up of bacteria.

Use the original packaging including polystyrene blocks to pack the coffee machine.

Also pack the operating instructions so that they are available when the coffee machine is next used.

Accessories

These products and other useful accessories can be ordered via the Miele webshop, from Miele (see back cover for contact details) or from your Miele dealer.

- **Microfibre cloth**
for removing finger marks and light soiling
- **Cleaning agent for milk pipework**
for cleaning the milk system
- **Cleaning tablets**
for degreasing the brew unit
- **Descaling cartridge**
for automatic descaling
- **Descaling tablets**
for manual descaling
- **CJ Jug 1.0 l**
Insulated flask for coffee or tea (pot function)
- **Miele Black Edition One for all**
Whole coffee beans – perfect for making espresso, café crema and speciality coffees with milk
- **Miele Black Edition Espresso**
Whole coffee beans – perfect for making espresso
- **Miele Black Edition Café Crema**
Whole coffee beans – perfect for making coffee
- **Miele Black Edition Decaf**
Whole coffee beans – perfect for making decaffeinated speciality coffees

The following tips can help you save energy and money as well as care for the environment:

- Operate the coffee machine in “Eco mode” (default setting).
- Select dimmer lighting or abstain from using lighting when the appliance is switched on.
- Switch off the lighting switch-off time when the appliance is switched off.
- Switch off the clock display.
- Energy consumption may increase if you change the settings for the “timers”.

This setting uses more energy **appears in the display.**

- Switch the coffee machine off with the On/Off sensor ① if it is not going to be used for a while.
- Change the setting for the “Switch off after” timer to 20 minutes. The coffee machine will then switch itself off 20 minutes after the last drink was made or a sensor was touched.
- If you only want to pre-heat your cups occasionally, you can switch the cup heating surface off. You can use hot water to pre-heat the cups instead.

Electrical connection

Before connecting the coffee machine, make sure that the connection data on the data plate (voltage and frequency) matches that of the electricity supply. This data must match in order to avoid the risk of damage to the coffee machine. If in any doubt, consult a qualified electrician.

The required connection data is provided on the data plate. The data plate can be seen on the left-hand side of the machine when the drip tray is pulled out.

The appliance is supplied with a mains cable ready for connection to an AC 220–240 V 50 Hz supply.

The coffee machine must be connected to the mains supply via a suitable earthed socket. Connection must comply with national and local safety regulations (BS 7671 in the UK).

The fuse rating must be at least 10 A.

The socket should be next to the appliance and easily accessible where possible.

Do not connect the coffee machine to the mains electricity supply using a multi-socket adapter or an extension lead. These do not guarantee the required safety of the machine (fire risk).

Do not connect the coffee machine to a **stand-alone inverter**. Stand-alone inverters are used for autonomous power supply, e.g. a solar power system. Power surges could trigger the Auto switch off function. This could damage the electronic module.

The coffee machine must not be used with “**energy saving plugs**”. These reduce the amount of energy supplied to the appliance, causing it to overheat.

If the mains connection cable is faulty, it must only be replaced by a qualified electrician in order to avoid a hazard.

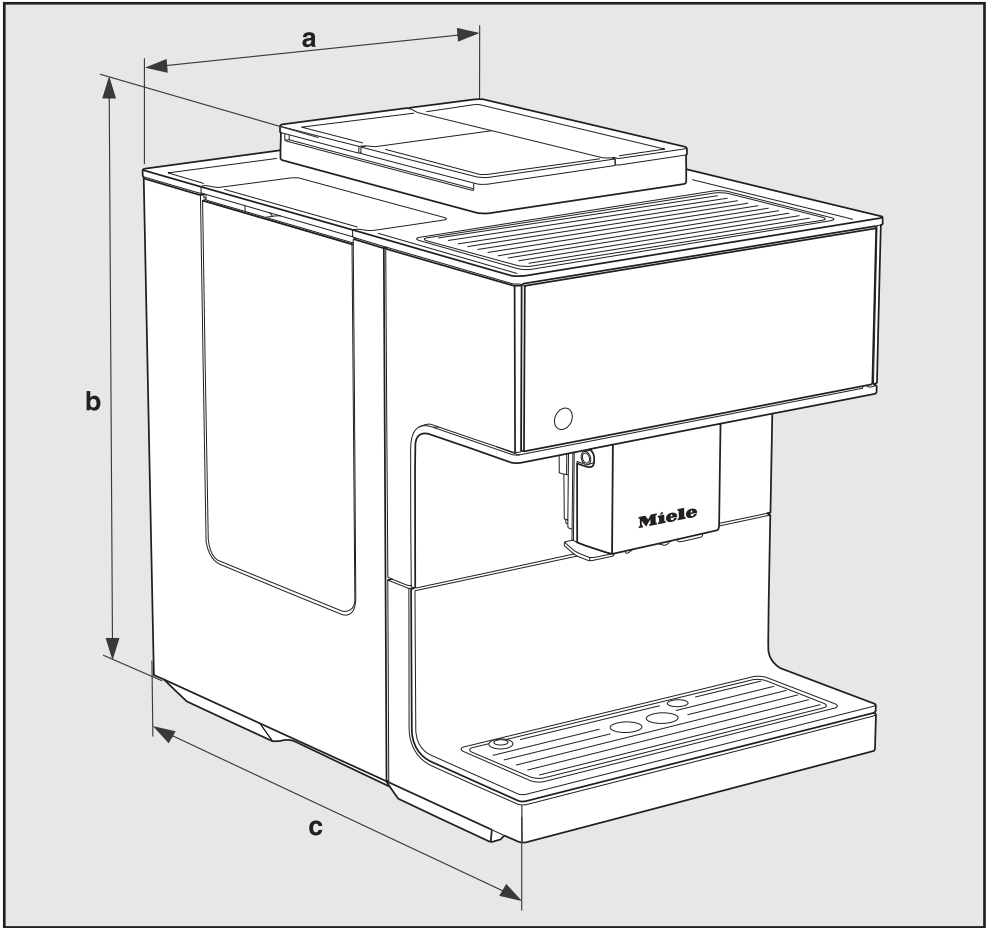

a = 311 mm

b = 420 mm

c = 445 mm

Technical data

Electricity consumption in standby:	< 0.4 W
Electricity consumption in networked standby:	< 0.9 W
Pump pressure:	Max. 15 bar
Through-flow heater:	1 stainless steel thermo block
Dimensions (W x H x D):	311 x 420 x 445 mm
Net weight:	14.2 kg
Connection cable length:	120 cm
Water container capacity:	2.2 l
Total capacity of bean containers:	
Coffee bean container A:	Approx. 540 g
Coffee bean container B:	Approx. 150 g
Coffee bean container C:	Approx. 210 g
	Approx. 180 g
Milk flask capacity:	0.5 l
Drip tray capacity:	0.8 l
Waste container capacity:	Max. 16 portions of coffee grounds
Central spout:	Height adjustable from 80–160 mm
Grinder:	Steel conical grinder
Grinder setting:	5 settings
Ground coffee amount:	Max. 12 g
Frequency band:	2.400–2.4835 GHz
Max. transmission power	< 100 mW

EU Conformity declaration

Miele hereby declares that this coffee machine complies with Directive 2014/53/EU.

The complete text of the EU declaration of conformity is available from one of the following internet addresses:

- Products, Download from www.miele.ie
- For service, information, operating instructions etc: go to www.miele.ie/domestic/customer-information-385.htm and enter the name of the product or the serial number

UK Conformity declaration

Miele hereby declares that this coffee machine complies with UK Radio Equipment Regulations 2017, as amended.

The complete text of the UK declaration of conformity is available from one of the following internet addresses:

- Products, Download from www.miele.co.uk
- For service, information, operating instructions etc: go to www.miele.co.uk and enter the name of the product or the serial number

United Kingdom

Miele Co. Ltd., Fairacres, Marcham Road, Abingdon, Oxon, OX14 1TW

Tel: 0330 160 6600, Internet: www.miele.co.uk/service, E-mail: info@miele.co.uk

Australia

Miele Australia Pty. Ltd.

ACN 005 635 398

ABN 96 005 635 398

Level 4, 141 Camberwell Road

Hawthorn East, VIC 3123

Tel: 1300 464 353

Internet: www.miele.com.au

China Mainland

Miele Electrical Appliances Co., Ltd.

1-3 Floor, No. 82 Shi Men Yi Road

Jing' an District

200040 Shanghai, PRC

Tel: +86 21 6157 3500

Fax: +86 21 6157 3511

E-mail: info@miele.cn,

Internet: www.miele.cn

Hong Kong, China

Miele (Hong Kong) Ltd.

41/F - 4101, Manhattan Place

23 Wang Tai Road

Kowloon Bay, Hong Kong

Tel: (852) 2610 1025

Fax: (852) 3579 1404

Email:

customerservices@miele.com.hk

Website: www.miele.hk

India

Miele India Pvt. Ltd.

1st Floor, Copia Corporate Suites,

Commercial Plot 9,

Mathura Road, Jasola,

New Delhi - 110025

E-mail: customercare@miele.in

Website: www.miele.in

Ireland

Miele Ireland Ltd.

2024 Bianconi Avenue

Citywest Business Campus

Dublin 24

Tel: (01) 461 07 10

Fax: (01) 461 07 97

E-Mail: info@miele.ie

Internet: www.miele.ie

Malaysia

Miele Sdn Bhd

Suite 12-2, Level 12

Menara Sapura Kencana

Petroleum

Solaris Dutamas No. 1

Jalan Dutamas 1

50480 Kuala Lumpur, Malaysia

Phone: +603-6209-0288

Fax: +603-6205-3768

New Zealand

Miele New Zealand Limited

IRD 98 463 631

8 College Hill

Freemans Bay, Auckland 1011

New Zealand

Tel: 0800 464 353

Internet: www.miele.co.nz

Singapore

Miele Pte. Ltd.

29 Media Circle

#11-04 ALICE@Mediapolis

Singapore 138565

sTel: +65 6735 1191

Fax: +65 6735 1161

E-Mail: info@miele.com.sg

Internet: www.miele.sg

South Africa

Miele (Pty) Ltd.

63 Peter Place

Bryanston 2194

P.O. Box 69434

Bryanston 2021

Tel: (011) 875 9000

Fax: (011) 875 9035

E-mail: info@miele.co.za

Internet: www.miele.co.za

Thailand

Miele Appliances Ltd.

BHIRAJ TOWER at EmQuartier

43rd Floor Unit 4301-4303

689 Sukhumvit Road

North Klongton Sub-District

Vadhana District

Bangkok 10110, Thailand

United Arab Emirates

Miele Appliances Ltd.

Showroom 1

Eiffel 1 Building

Sheikh Zayed Road, Umm Al Sheif

P.O. Box 114782 - Dubai

Tel. +971 4 3044 999

Fax. +971 4 3418 852

800-MIELE (64353)

E-Mail: info@miele.ae

Website: www.miele.ae

Manufacturer: Miele & Cie. KG, Carl-Miele-Straße 29, 33332 Gütersloh, Germany

CM 7750 CoffeeSelect

en-GB

M.-Nr. 11 674 752 / 00