

71/358

Library Copy

NEW #1

**IMPORTANT MANUAL**

**Do Not Throw Away**

M-5605890

**SEARS**

**Operator's  
Manual**

Model No.  
358.798490

**CUSTOMER  
ASSISTANCE  
1-800-235-5878**

HOURS (CST)  
Mon - Sat. 7 a.m. - 7 p.m.  
Sun. 10 a.m. - 7 p.m.



**WARNING:**

**READ THE OPERATOR'S  
MANUAL AND FOLLOW  
ALL WARNINGS AND  
SAFETY INSTRUCTIONS.  
FAILURE TO DO SO CAN  
RESULT IN SERIOUS  
INJURY.**

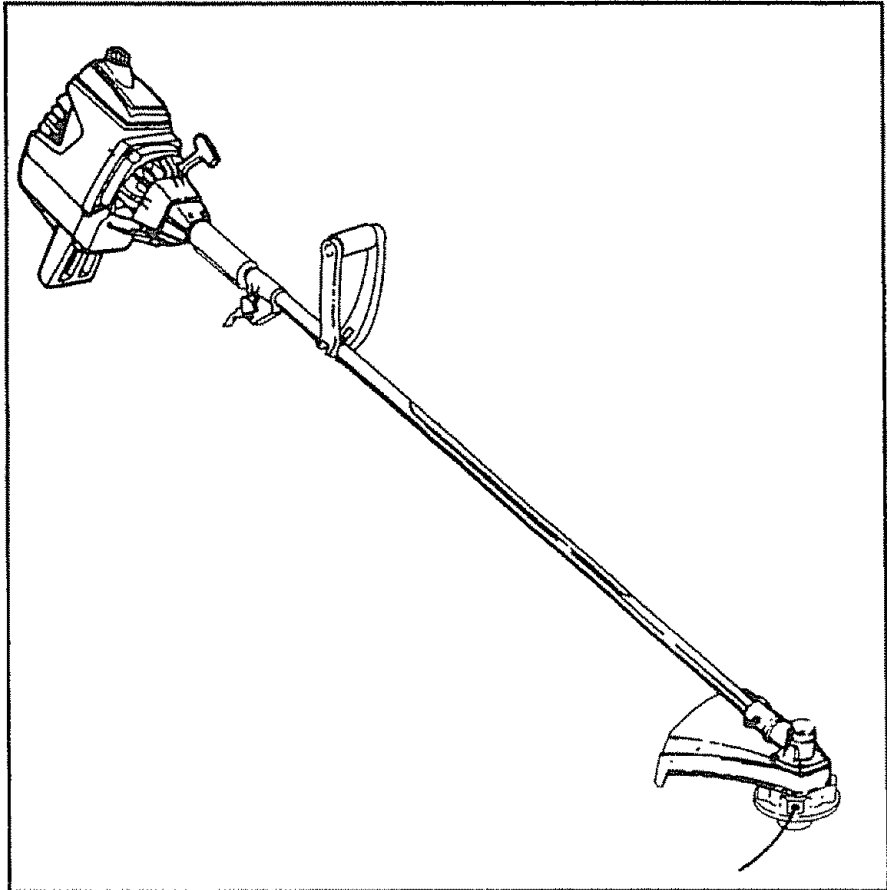

*Always Wear Eye Protection*

**CRAFTSMAN®**

**32 cc/2.0 cu. in. 2-CYCLE  
17 Inch Semi-Automatic Head  
GAS WEEDWACKER®**

- Assembly
- Operation
- Customer Responsibilities
- Service and Adjustments
- Repair Parts

Sears, Roebuck and Co., Hoffman Estates, IL 60179 U.S.A.



# SAFETY RULES



**CAUTION: ALWAYS DISCONNECT SPARK PLUG WIRE AND PLACE WIRE WHERE IT CANNOT CONTACT SPARK PLUG TO PREVENT ACCIDENTAL STARTING WHEN SETTING UP, TRANSPORTING, ADJUSTING OR MAKING REPAIRS.**

## OPERATOR SAFETY

- Always wear safety eye protection
- Always wear long pants, long sleeves, boots and gloves. Wearing safety leg guards is recommended. Do not go barefoot or wear sandals, short pants, short sleeves. Being fully covered helps to protect you from pieces of toxic plants thrown by the cutting head.
- Secure hair so it is above shoulder length. Secure loose clothing, jewelry, or clothing with loosely hanging ties, straps, tassels, etc.; they can be caught in moving parts
- Do not operate this unit when you are tired, ill, or under the influence of alcohol, drugs, or medication.
- Wear hearing protection if you use this unit for more than 1-1/2 hours per day.
- Never start or run the engine inside a closed room or building. Breathing exhaust fumes can kill.
- Keep handles free of oil and fuel.
- If situations occur which are not covered in this manual, use care and good judgement

## UNIT/MAINTENANCE SAFETY

- Look for and replace damaged or loose parts before each use. Look for and repair fuel leaks before use. Keep the unit in good working condition.
- Use only .080" diameter monofilament line. Never use wire, rope, string, etc.
- Keep the cutting line at the proper length
- Make sure the unit is maintained and assembled correctly as listed in this manual.
- Install the required shield properly before using the unit
- Use only the specified semi-automatic trimmer head.
- Make carburetor adjustments with the lower end supported to prevent the trimmer line from contacting any object. Hold unit by hand
- Keep others away when making carburetor adjustments
- Use only good quality SEARS accessories as recommended for this unit.

## FUEL SAFETY

- Mix and pour fuel outdoors.
- Keep away from sparks or flames.
- Use a container approved for fuel

- Do not smoke or allow smoking near fuel or the unit or while using the unit.
- Wipe up all fuel spills before starting engine.
- Move at least 10 feet (3 meters) away from fueling site before starting engine.
- Stop engine and allow unit to cool before removing fuel cap.

## CUTTING SAFETY

- Inspect the area to be cut before each use. Remove objects (rocks, broken glass, nails, wire, string, etc.) which can be thrown or become entangled in the semi-automatic line head
- Keep others including children, animals, bystanders and helpers at least 50 feet (15 meters) away. Stop the engine immediately if you are approached.
- Always keep the engine on the right-hand side of your body.
- Hold the unit firmly with both hands.
- Keep firm footing and balance. Do not over-reach
- Keep the semi-automatic line head below waist level
- Do not raise the engine above your waist.
- Keep all parts of your body away from semi-automatic line head and muffler when engine is running.
- Cut from your right to your left.
- Use only for jobs explained in this manual.

## TRANSPORTING AND STORAGE

- Stop the unit before transporting.
- Allow the engine to cool, and secure the unit before storing or transporting in a vehicle.
- Empty the fuel tank before storing or transporting the unit. Use up any fuel left in the carburetor by starting the engine and letting the engine run until it stops.
- Store unit and fuel in an area where fuel vapors cannot reach sparks or open flames from water heaters, electric motors or switches, furnaces, etc.
- Store unit so the line limiter cannot accidentally cause injury.
- Store the unit out of the reach of children.

## SAFETY NOTICE

Exposure to vibrations through prolonged use of gasoline powered hand units could cause blood vessel or nerve damage in the fingers, hands, and joints of people prone to circulation disorders or abnormal swellings. Prolonged use in cold weather has been linked to blood vessel damage in otherwise healthy people. If symptoms occur such as numbness, pain, loss of strength, change in skin color or texture, or loss of feeling in the fingers, hands or joints, discontinue the use of this unit and seek medical attention. An anti-vibration system does not guarantee the avoidance of these problems. Users who operate power tools on a continual and regular basis must monitor closely their physical condition and the condition of this unit.



**LOOK FOR THIS SYMBOL TO POINT OUT IMPORTANT SAFETY PRECAUTIONS. IT MEANS — ATTENTION!!! BECOME ALERT!!! YOUR SAFETY IS INVOLVED.**

# SAFETY RULES



## DANGER

**THIS POWER UNIT CAN BE DANGEROUS! THIS UNIT CAN CAUSE SERIOUS INJURY OR BLINDNESS TO THE OPERATOR AND OTHERS. THE WARNINGS AND SAFETY INSTRUCTIONS IN THIS MANUAL MUST BE FOLLOWED TO PROVIDE REASONABLE SAFETY AND EFFICIENCY IN USING THIS UNIT. THE OPERATOR IS RESPONSIBLE FOR FOLLOWING THE WARNINGS AND INSTRUCTIONS IN THIS MANUAL AND ON THE UNIT. READ THE ENTIRE OPERATOR'S MANUAL BEFORE ASSEMBLING AND USING THE UNIT! RESTRICT THE USE OF THIS POWER UNIT TO PERSONS WHO READ, UNDERSTAND AND FOLLOW THE WARNINGS AND INSTRUCTIONS IN THIS MANUAL AND ON THE UNIT. NEVER ALLOW CHILDREN TO USE THIS TOOL.**

**THIS UNIT IS DESIGNED FOR LINE TRIMMER USE ONLY. NEVER USE ANY OTHER CUTTING ATTACHMENT WITH THIS UNIT. BLADES AND HEADS WITH FLAILING DEVICES CAN CAUSE SERIOUS INJURY.**

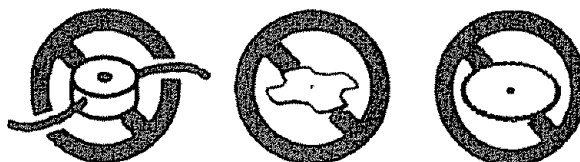

## WARNING

**TRIMMER LINE CAN THROW OBJECTS VIOLENTLY. YOU CAN BE BLINDED OR INJURED. WEAR EYE AND LEG PROTECTION.**

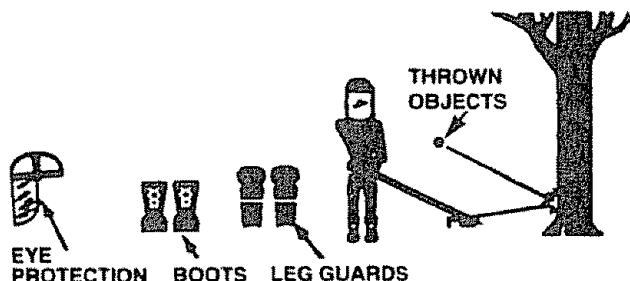

**HAZARD ZONE FOR THROWN OBJECTS. TRIMMER LINE CAN THROW OBJECTS VIOLENTLY. OTHERS CAN BE BLINDED OR INJURED. KEEP PEOPLE AND ANIMALS 50 FEET (15 METERS) AWAY.**

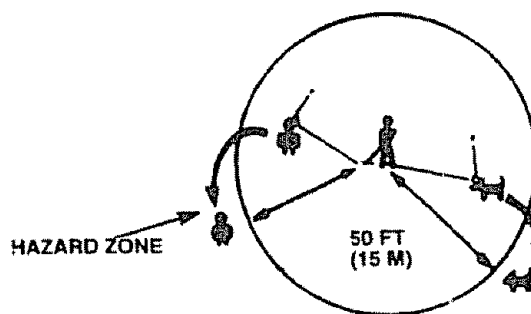

**READ OPERATOR'S MANUAL. FOLLOW ALL WARNINGS AND INSTRUCTIONS. FAILURE TO DO SO CAN RESULT IN SERIOUS INJURY.**



OPERATOR'S  
MANUAL



SAFETY  
LABEL

CONGRATULATIONS on your purchase of a Sears Craftsman Gas Weedwacker. It has been designed, engineered and manufactured to give you the best possible dependability and performance.

Should you experience any problems you cannot easily remedy, please contact your nearest Sears Service Center/Department. Sears has competent, well trained technicians and the proper tools to service or repair this unit.

Please read and retain this manual. The instructions will enable you to assemble and maintain your unit properly. Always observe the "SAFETY RULES."

MODEL NUMBER:	<b>358.798490</b>
DATE CODE/SERIAL NO.:	_____
DATE OF PURCHASE:	_____
THE MODEL AND SERIAL NUMBER WILL BE FOUND ON THE PRODUCT.	
YOU SHOULD RECORD BOTH SERIAL NUMBER AND DATE OF PURCHASE AND KEEP IN A SAFE PLACE FOR FUTURE REFERENCE.	

**MAINTENANCE AGREEMENT**

A Sears Maintenance Agreement is available on this product. Contact your nearest Sears Store for details.

**CUSTOMER RESPONSIBILITIES**

- Read and observe the safety rules.
- Follow a regular schedule in maintaining, caring for, and using your unit.
- Follow the instructions under "Customer Responsibilities" and "Storage" sections of this Operator's Manual.

**PRODUCT SPECIFICATIONS**

CUTTING PATH	17" (43cm)
TRIMMER LINE	.080" Diameter Monofilament
SEMI-AUTOMATIC HEAD ROTATION	Counterclockwise (for operator)
ENGINE	32cc, 2-cycle Air Cooled
FUEL/OIL MIX RATIO	40:1 (3.2 oz. oil per gallon gas)
IGNITION	Solid State (air gap .010" to .014")
IGNITION TIMING	Non-adjustable, fixed
SPARK PLUG	Champion (RCJ-8Y)
SPARK PLUG GAP	.025" (.6mm)
ENGINE RPM	7,500 RPM Max

**SPECIAL NOTICE**

For users on U.S. Forest Land and in some states, including California (Public Resources Codes 4442 and 4443), Idaho, Maine, Minnesota, New Jersey, Oregon, and Washington: Certain internal combustion engines operated on forest, brush, and/or grass-covered lands in the above areas are required to be equipped with a spark arrestor, maintained in effective working order, or the engine must be constructed, equipped, and maintained for the prevention of fire. Check with your state or local authorities for regulations pertaining to these requirements. Failure to follow these requirements is a violation of the law. This unit is not factory-equipped with a spark arrestor; however, a spark arrestor is available as an optional part. If a spark arrestor is required in your area, contact your SEARS Service Center/Department for the correct kit.

Manufactured under one or more of the following U.S. patents 5 383 427 5 367 988  
5 345 684 5 343 831 5 276 968 5 269 665 5 020 223 4 940 028 4 897 923 4 852 258  
4 846 123 4 841 929 4 835 867 4 825 548 4 823 465 4 819 742 4 798 185 4 508 068  
4 483 069 4 451 983 4 366 622 4 366 621 4 352 243 4 347 666 4 290 200 4 286 675  
4 236 312 4 177 561 4 172 322 4 167 812 4 162 575 4 161 820 4 122 653 4 104 797  
Re 32,266 D344 088 D324 051 D304 196 D276 160 Other U.S. and foreign patents pending

**FULL ONE YEAR WARRANTY ON CRAFTSMAN GAS-POWERED WEEDWACKER® LINE TRIMMER**

For one year from the date of purchase, when this Craftsman Gas-Powered Weedwacker® Line Trimmer is maintained, lubricated and tuned-up according to the operating and maintenance instructions in the operator's manual, Sears will repair, free of charge, any defect in materials or workmanship.

This warranty excludes nylon line, spark plug, and air filter, which are expendable parts and become worn during normal use.

If this Weedwacker® Line Trimmer is used for commercial purposes, this warranty applies for only 90 days from the date of purchase. If this Weedwacker® Line Trimmer is used for rental purposes, this warranty applies for only 30 days from date of purchase. This warranty applies only while this product is in use in the United States.

WARRANTY SERVICE IS AVAILABLE BY RETURNING THE WEEDWACKER® LINE TRIMMER TO THE NEAREST SEARS SERVICE CENTER IN THE UNITED STATES.

This warranty gives you specific legal rights, and you may also have other rights which vary from state to state.

**SEARS, ROEBUCK AND CO., D/817WA, HOFFMAN ESTATES, IL 60179**



# TABLE OF CONTENTS







Safety Rules .....	2	Customer Responsibilities .....	14
Product Specifications .....	4	Service and Adjustments .....	17
Warranty .....	4	Storage .....	21
Accessories .....	5	Trouble Shooting .....	22
Assembly .....	7	Repair Parts .....	23
Operation .....	8	Repair Parts Ordering/Service .....	Back Cover

## INDEX

<p style="text-align: center;"><b>A</b></p> <p>Accessories .....</p> <p>Adjustments</p> <p style="padding-left: 20px;">Assist Handle .....</p> <p style="padding-left: 20px;">Carburetor .....</p> <p>Air Filter .....</p> <p>Assembly .....</p> <p>Assist Handle .....</p> <p style="text-align: center;"><b>C</b></p> <p>Carburetor Adjustments .....</p> <p>Carton Contents .....</p> <p>Controls .....</p> <p>Customer Responsibilities .....</p> <p style="padding-left: 20px;">Spark Plug .....</p> <p>Cutting Techniques .....</p> <p style="text-align: center;"><b>D</b></p> <p>Debris Shield .....</p> <p>Drive Shaft Lubrication .....</p> <p style="text-align: center;"><b>E</b></p> <p>Engine</p> <p style="padding-left: 20px;">Fuel/Oil .....</p> <p style="padding-left: 20px;">Spark Plug .....</p> <p style="padding-left: 20px;">Starting .....</p> <p style="padding-left: 20px;">Storage .....</p> <p style="text-align: center;"><b>F</b></p> <p>Fueling .....</p> <p>Fuel Filter .....</p>	<p style="text-align: center;"><b>K</b></p> <p>Know Your Weedwacker .....</p> <p style="text-align: center;"><b>L</b></p> <p>Line Advancement .....</p> <p>Line Replacement .....</p> <p style="text-align: center;"><b>M</b></p> <p>Maintenance Schedule .....</p> <p>Model Number .....</p> <p style="text-align: center;"><b>O</b></p> <p>Operation .....</p> <p>Ordering Repair Parts .....</p> <p style="text-align: center;"><b>R</b></p> <p>Repair Parts .....</p> <p style="padding-left: 20px;">Ordering .....</p> <p style="text-align: center;"><b>S</b></p> <p>Service and Adjustments .....</p> <p>Spark Arrestor Screen .....</p> <p>Specifications .....</p> <p>Starting .....</p> <p>Storage .....</p> <p style="text-align: center;"><b>T</b></p> <p>Trouble Shooting .....</p> <p style="text-align: center;"><b>W</b></p> <p>Warranty .....</p>
--	--

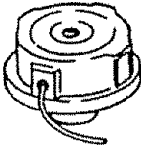
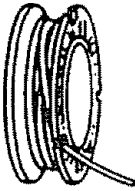
## ACCESSORIES

These accessories and attachments were available when the unit was originally purchased. They are also available at most Sears retail outlets and service centers. Most Sears stores can order these items for you when you provide the model number of your unit.

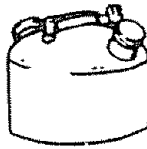
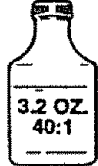
Accessories								
<b>SAFETY GOGGLES</b>	<b>HEARING PROTECTION</b>	<b>SEMI-AUTOMATIC LINE HEAD</b>	<b>SPOOL WITH LINE</b>	<b>BULK LINE</b>	<b>SPARK PLUG</b>	<b>AIR FILTER</b>	<b>GAS CAN</b>	<b>SEARS 2-CYCLE ENGINE OIL</b>
				 <small>.080" 80 FT. 200 FT. 400 FT.</small>				 <small>3.2 OZ. 40:1</small>



# CARTON CONTENTS

Hardware shown full size

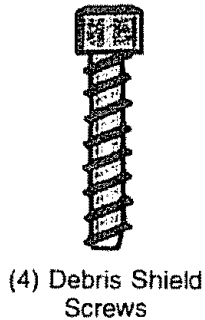

(1) Flat Washer

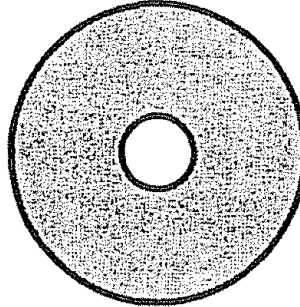

Grass Washer

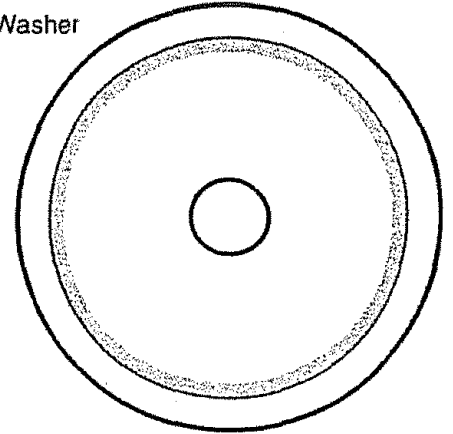

Parts bag contents not shown full size

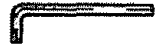

Short Hex Key



Long Hex Key

Parts packed separately in carton

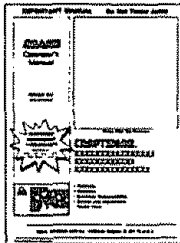

Operator's  
Manual

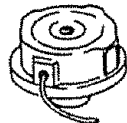

Semi-automatic  
Head

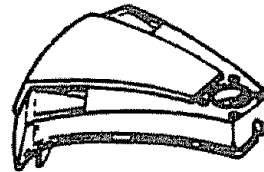

Plastic  
Debris Shield

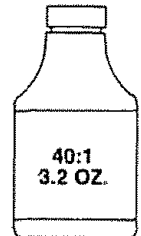

40:1  
3.2 OZ.  
Engine Oil

## ASSEMBLY

### TOOLS REQUIRED FOR ASSEMBLY

- Torque Wrench (optional) – Reference torque values are provided throughout this manual for tightening hardware.
- Long Hex Wrench
- Short Hex Wrench

### TO REMOVE WEEDWACKER FROM CARTON

- Remove loose parts bag included with Weedwacker.
- Remove your Weedwacker from the packing material.
- You may use the opened packing material as a work surface.

- After removing the contents from the carton, check parts against the Carton Contents list.
- Examine the parts for damage. Do not use damaged parts.
- *Notify Customer Assistance at 1-800-235-5878 immediately if a part is missing or damaged.*

**NOTE:** It is normal to hear the fuel filter rattle in an empty fuel tank.

# ASSEMBLY

## HOW TO ASSEMBLE YOUR WEEDWACKER



**WARNING:**  
IF THIS UNIT IS RECEIVED ASSEMBLED, REVIEW ALL STEPS IN THIS ASSEMBLY SECTION FOR PROPER ADJUSTMENT AND CORRECT ASSEMBLY.

WHEN ADJUSTING THE ASSIST HANDLE FOR COMFORT, BE SURE THAT THE ASSIST HANDLE REMAINS BETWEEN THE TRIGGER HOUSING AND THE SAFETY LABEL.

### ASSIST HANDLE ASSEMBLY (Fig. 1)

**NOTE:** For pre-assembled units, simply loosen assist handle knob and rotate assist handle to the operating position, being sure to align between safety label and throttle trigger housing.

- Rotate assist handle from left to right to tilt the angle of the semi-automatic head when cutting a large, sloped area such as a ditch bank.
- Tighten knob securely.

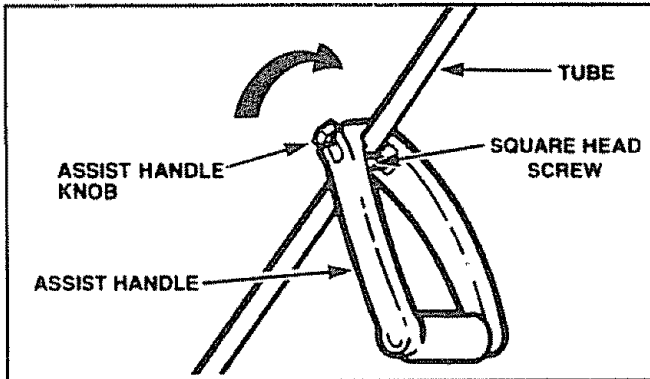

Figure 1

### INSTALLING THE PLASTIC DEBRIS SHIELD (Fig. 2)



**WARNING:**  
THE LINE LIMITER IS SHARP AND CAN CUT YOU. BE SURE TO WEAR GLOVES WHILE WORKING WITH THE PLASTIC DEBRIS SHIELD OR LINE LIMITER.

THE PLASTIC DEBRIS SHIELD MUST BE PROPERLY INSTALLED FOR ALL LINE TRIMMER USAGE. THE DEBRIS SHIELD PROVIDES PARTIAL PROTECTION FROM THE RISK OF THROWN OBJECTS TO THE OPERATOR AND OTHERS.

WHEN INSTALLED CORRECTLY, THE PLASTIC DEBRIS SHIELD WILL BE IN PROPER ALIGNMENT. FAILURE TO INSTALL THE DEBRIS SHIELD IN POSITION SHOWN IN ILLUSTRATION CAN RESULT IN SERIOUS INJURY TO THE OPERATOR.

- Remove the packing cover from the arbor shaft if so equipped.
- Remove the dust cup from the arbor shaft (ref Fig. 2).

- Place plastic debris shield under the gear box and align screw holes. Make sure the widest part of the plastic debris shield is pointing toward the engine.
- Insert the four shield screws through the gear box into the plastic debris shield.
- Tighten screws evenly and securely using the long hex key provided

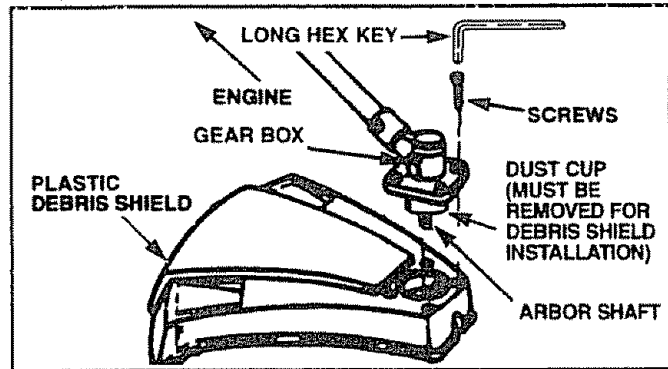

Figure 2

### SEMI-AUTOMATIC HEAD ASSEMBLY (Fig. 3)

- Ensure the plastic debris shield is in place and secured.
- Install dust cup over the arbor shaft.
- Align the hole in the dust cup with the hole in the center front of the gear box by turning the dust cup.
- Install the grass washer over the arbor shaft. Make sure the grass washer is against and curved over the dust cup.
- Install the flat washer over the arbor shaft.
- Start threading the semi-automatic head onto the arbor shaft (counterclockwise).
- Insert the short hex key (provided) into the aligned holes to keep the arbor shaft from turning.
- Tighten the semi-automatic head while holding the short hex key.
- Remove the short hex key.

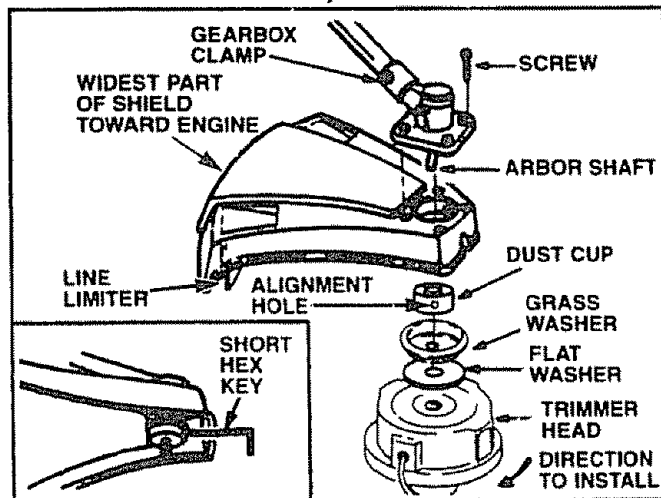

Figure 3

### CHECK LIST

- Check all fasteners. make sure they are tight and there are no loose parts.
- Check to make sure the *throttle cable* is positioned correctly.
- With the unit held in the operating position, adjust the assist handle up or down the tube for best comfort and balance before first use.

---

# OPERATION

---

## KNOW YOUR WEEDWACKER (Fig. 4)

READ THIS OPERATOR'S MANUAL AND SAFETY RULES BEFORE OPERATING YOUR WEEDWACKER. Compare the illustrations with your unit to familiarize yourself with the location of the various controls and adjustments. Save this manual for future reference.

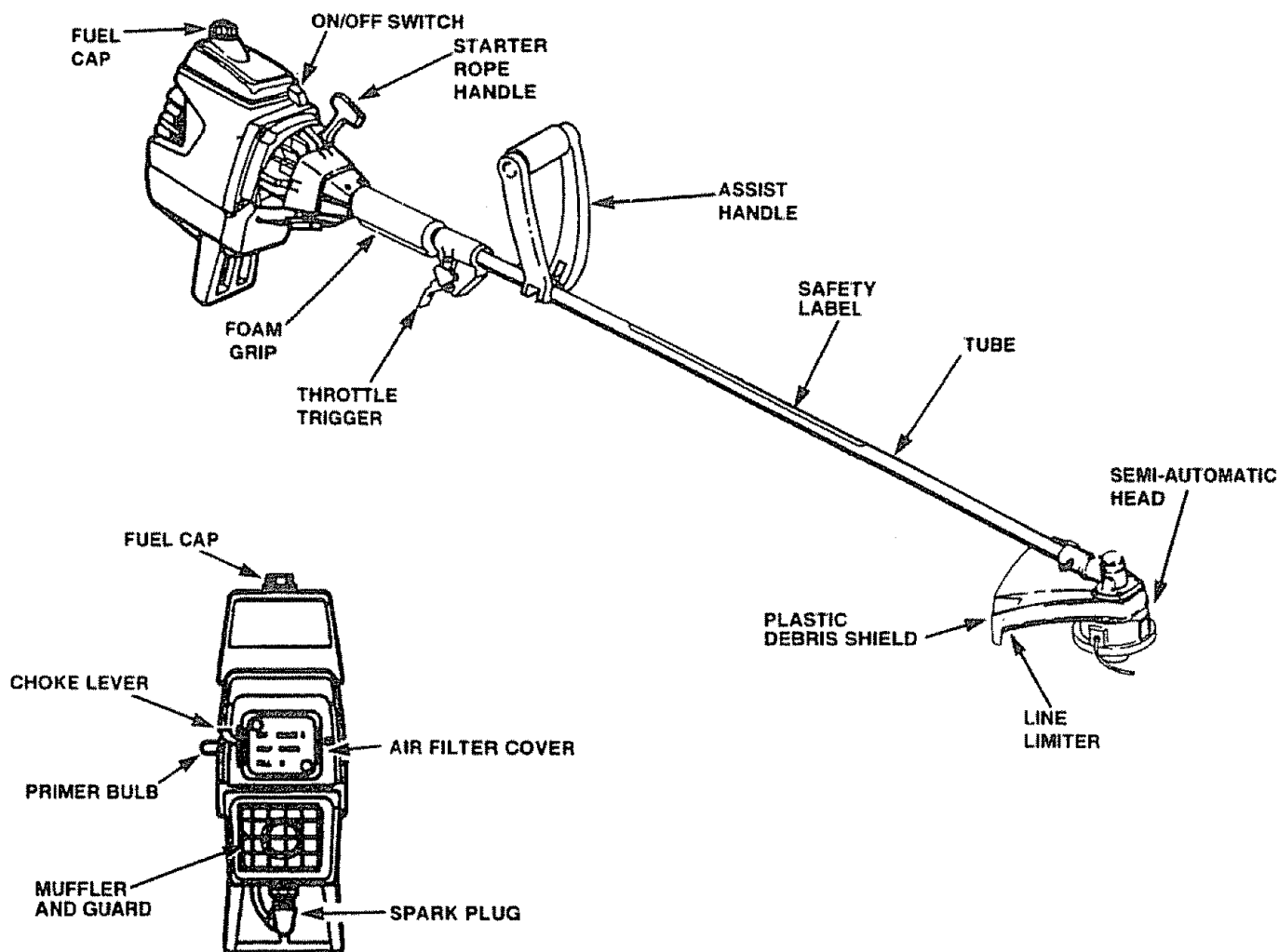

---

Figure 4

The ON/OFF SWITCH is used to stop the engine.

The STARTER ROPE HANDLE is used for starting the engine.

The PRIMER BULB circulates fuel to the carburetor.

The ASSIST HANDLE aids in the control of the unit.

The CHOKE LEVER is used for starting a cold engine.

The THROTTLE TRIGGER controls engine speed.

The SEMI-AUTOMATIC HEAD contains spool of line which advances when the head is tapped on the ground.

The LINE LIMITER cuts trimmer line automatically to the correct length.

# OPERATION

## HOW TO USE YOUR WEEDWACKER

### STOPPING YOUR ENGINE

- Move on/off switch to the "Off" position.
- If engine does not stop, move the choke lever down (full choke)

### CONTROLS (Fig. 5, 6 & 7)

#### THROTTLE TRIGGER

- The throttle trigger allows for variable control of engine speed.
- The throttle trigger is actuated by the index finger on your right hand.

#### CHOKE

- The choke is set by moving the choke lever down fully for cold or refueled engine starts.

#### PRIMER BULB

- The primer bulb is used to circulate fuel to the carburetor.
- The primer bulb is activated by pressing on it with your thumb.

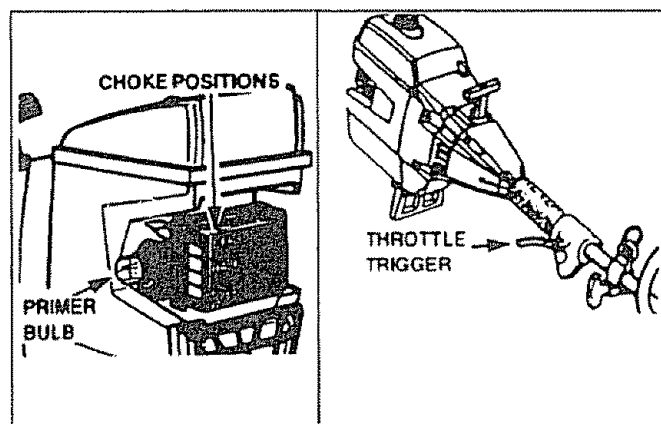

Figure 5

#### ASSIST HANDLE

The assist handle is used to aid in the control of the unit, as well as a barrier between the operator and the cutting head.

#### TO ADJUST THE ASSIST HANDLE FOR BALANCE AND CONTROL:

- Turn off the engine before adjusting handlebar.
- Adjust the handlebar by slightly loosening the handlebar knob and rotating the handlebar forward or backward. Adjust the assist handle up or down the tube (*but above the safety label*).
- Rotate the assist handle from left to right to tilt the angle of the semi-automatic head when cutting a large sloped area such as a ditch bank.
- Tighten the handlebar knob before starting the engine.

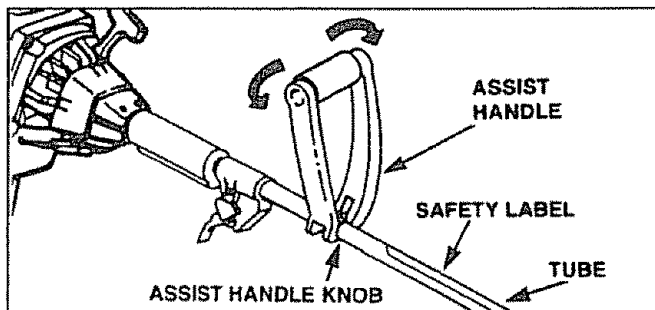

Figure 6

#### TRIMMER LINE ADVANCE

Your Weedwacker is equipped with a semi-automatic trimmer head. The most efficient line length is the maximum length allowed by the line limiter.

#### TO ADVANCE THE LINE:

- Operate the engine at full throttle.
- Hold the semi-automatic head parallel to and above a grassy area.
- Tap the bottom of the semi-automatic head lightly on the ground one time. Approximately 2 inches of line will be advanced with each tap.

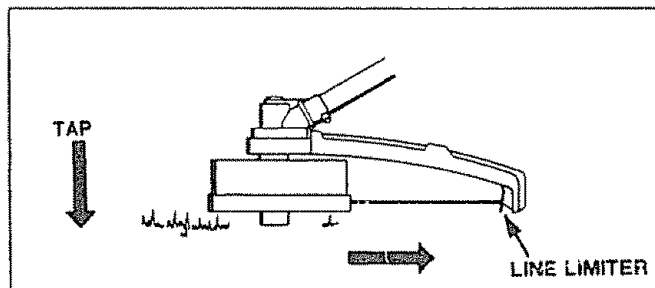

Figure 7

# OPERATION

## BEFORE STARTING ENGINE:



**WARNING:**  
**BE SURE TO READ THE FUEL SAFETY INFORMATION IN THE SAFETY RULES SECTION ON PAGE 2 OF THIS MANUAL BEFORE YOU BEGIN.**

**IF YOU DO NOT UNDERSTAND THE FUEL SAFETY SECTION DO NOT ATTEMPT TO FUEL YOUR UNIT; SEEK HELP FROM SOMEONE WHO DOES UNDERSTAND THE FUEL SAFETY SECTION OR CALL THE CUSTOMER ASSISTANCE HOTLINE AT 1-800-235-5878.**

## GASOLINE

The two-cycle engine on this product requires a fuel mixture of regular unleaded gasoline and a high quality 40:1 2-cycle engine oil (AIR-COOLED) for lubrication of the bearings and other moving parts. The correct fuel/oil mixture is 40:1 (see Fuel Mixture Chart). Too little oil or the incorrect oil type will cause poor performance and may cause the engine to overheat and seize.

Gasoline and oil must be premixed in a clean approved fuel container. Always use fresh regular unleaded gasoline.

This engine is certified to operate on unleaded gasoline.

**IMPORTANT:** Experience indicates that alcohol blended fuels called gasohol (or using ethanol or methanol) can attract moisture, which leads to oil/gas separation and formation of acids during storage. Acidic gas can damage the fuel system of an engine while in storage. To avoid engine problems, the fuel system should be emptied before storage for 30 days or longer. Drain the gas tank, then run the fuel out of the carburetor and fuel lines by starting the engine and letting it run until it stops. Use fresh fuel next season. See STORAGE instructions for additional information. Never use engine or carburetor cleaner products in the fuel tank or permanent damage may occur.

## FUEL STABILIZER

Fuel stabilizer is an acceptable alternative in minimizing the formation of fuel gum deposits during storage. Add stabilizer to gasoline in fuel tank or storage container. Always follow the fuel tank or storage container. Always follow the fuel mix ratio found on the stabilizer container. Run engine at least 5 minutes after adding stabilizer to allow the stabilizer to reach the carburetor. You do not have to drain the fuel tank for storage if you are using fuel stabilizer.

CRAFTSMAN 40:1 2-cycle engine oil (AIR-COOLED) is specially blended with fuel stabilizers. If you do not use this Sears oil, you can add a fuel stabilizer (such as CRAFTSMAN No. 33500) to your fuel tank.

## 40:1 2-CYCLE AIR-COOLED ENGINE OIL

CRAFTSMAN 40:1 2-cycle engine oil (AIR-COOLED) is strongly recommended. This oil is specially blended with fuel stabilizers for increased fuel stability (extends fuel life up to 5 times longer) and reduced smoke.

If CRAFTSMAN 40:1 2-cycle engine oil (AIR-COOLED) is not available, use a good quality 2-cycle engine oil (AIR-COOLED) that has a recommended fuel mix ratio of 40:1.

### IMPORTANT! Do not use:

- AUTOMOTIVE OIL
- BOAT OILS (NMMA, BIA, etc.)

These oils do not have proper additives for 2-cycle AIR-COOLED engines and can cause engine damage.

## GASOLINE AND OIL MIXTURE

Mix gasoline and oil as follows:

- Consult chart for correct quantities.
- Do not mix gasoline and oil directly in the unit's fuel tank.

### FOR ONE GALLON:

- Pour 3.2 ounces of high quality, 40:1 2-cycle engine oil (AIR-COOLED) into an empty, approved one gallon gasoline container.
- Add one gallon of regular unleaded gasoline to the gallon container, then securely replace the cap.
- Shake the container.
- The mixture is now ready for use. Fuel stabilizer can be added at this time if desired; follow mixing instructions on the label.

## FUEL MIXTURE CHART

### 40:1 Fuel:Oil Mix Ratio

<u>Gasoline</u>	<u>Oil (fl. oz.)</u>
1 gallon	3.2
2.5 gallons	8.0

**NOTE:** Fuel containers may hold more than the specified amount. If too much gasoline is in the container, the resulting gas-to-oil fuel mixture will not be correct for proper engine operation.

# OPERATION

## STOPPING YOUR ENGINE

- Move the ON/OFF switch to the OFF position.
- If engine does not stop, move the choke lever down (full choke).



**WARNING:**  
THE SEMI-AUTOMATIC HEAD WILL TURN  
WHEN THE ENGINE STARTS.

FOR SAFE STARTING AND OPERATION,  
FOLLOW ALL SAFETY PRECAUTIONS IN  
THIS OPERATOR'S MANUAL AND  
LABELS ON THE UNIT. DRESS PROPERLY  
BEFORE STARTING ENGINE.

AVOID ANY CONTACT WITH THE MUFFLER.  
A HOT MUFFLER CAN CAUSE  
SERIOUS BURNS.

## TO START ENGINE (Fig. 8 & 9)

### COLD ENGINE START AND WARM ENGINE START AFTER RUNNING OUT OF FUEL

- Fuel engine with 40:1 fuel mix (3.2 oz. to 1 gal gas)  
Move 10 feet (3 meters) away from fueling site.

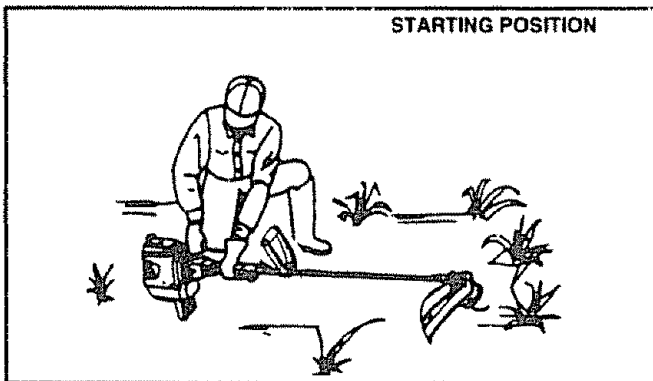

Figure 8

- Move ON/OFF switch to the ON position.
- Prime engine by pressing primer bulb six times.
- Actuate choke by moving the choke lever to the "Full Choke" position.
- Rest engine and debris shield on ground, supporting semi-automatic
- Squeeze and hold the throttle trigger. *Keep the throttle trigger fully squeezed until the engine runs smoothly.*

**NOTE:** When pulling the starter rope, do not use the full extent of the rope as this can cause the rope to break. Do not let the starter snap back. Hold the handle and let the rope rewind slowly.

- Pull starter rope sharply five times

The engine may sound as if it is trying to start before the fifth pull. If so, go to the next step immediately.

- Move the choke lever to the "Half Choke" position.
- Pull the starter rope sharply until the engine runs, but no more than six pulls.

Once the engine starts, allow the engine to run 15 seconds, then move the choke lever to "Off Choke." Allow the engine to run for 30 more seconds at "Off Choke" before releasing the throttle trigger.

**NOTE:** If the engine has not started after 6 pulls (at half choke), check to make sure the ON/OFF switch and the choke lever are in the proper positions. Then, move the choke lever to the full choke position and press the primer bulb 6 times; pull the starter rope 2 more times. Move the choke lever to half choke and pull the starter rope until the engine runs, but no more than 6 more pulls.

**NOTE:** If engine still has not started, it is probably flooded. Proceed to "Difficult Starting and Flooded Engine"

- Allow the engine to run 10 seconds, then move the choke lever to off choke. Allow the unit to run for 30 more seconds at "Off Choke," then release the throttle trigger.

**NOTE:** If engine dies with the choke lever at the "Off Choke" position, move the choke lever to half choke and pull the rope until the engine runs. Allow the unit to run for 30 more seconds at "Off Choke," then release the throttle trigger.

- To stop the engine, move the ON/OFF switch to the OFF position.

## STARTING A WARM ENGINE

- Move choke lever to the "Off Choke" position.
- Squeeze throttle trigger.
- Pull starter rope until engine starts.

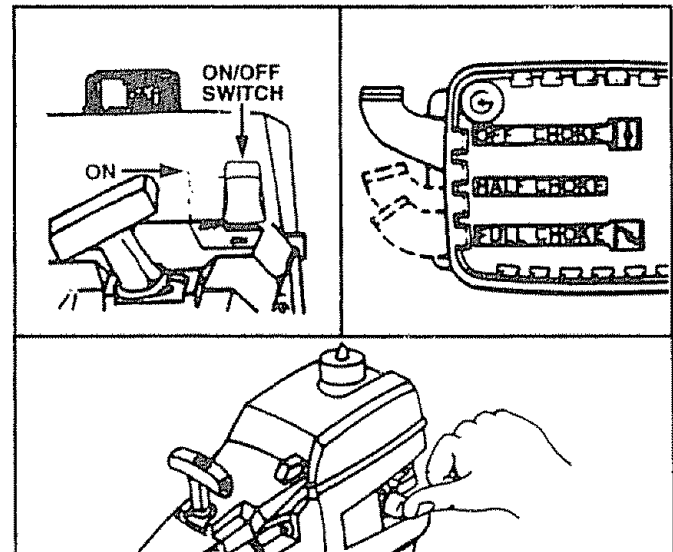

Figure 9

## DIFFICULT STARTING AND FLOODED ENGINE

The engine may be flooded with too much fuel if it has not started after 20 pulls.

Flooded engines can be cleared of excess fuel with the following procedure:

- Move the choke lever to the "Off Choke" position.
- Squeeze and hold the throttle trigger.
- Pull starter rope handle until engine starts.

Starting could require pulling starter rope handle many times depending on how badly unit is flooded.

If engine still fails to start, refer to "TROUBLE SHOOTING" chart or call the 1-800 number listed on the front cover of this manual.

# OPERATION SAFETY

## LINE TRIMMER SAFETY



### WARNING:

THE RAPIDLY MOVING LINE CAUSES OBJECTS TO BE THROWN VIOLENTLY. THE DEBRIS SHIELD WILL NOT PROVIDE COMPLETE PROTECTION TO THE OPERATOR OR OTHERS. THE OPERATOR MUST WEAR A SAFETY FACE SHIELD OR GOGGLES. ALWAYS WEAR HEAVY, LONG PANTS AND BOOTS. KEEP OTHERS AT LEAST 50 FEET (15 METERS) AWAY.

THIS UNIT WILL THROW OBJECTS AND CUT. KEEP OTHERS INCLUDING CHILDREN, ANIMALS, BYSTANDERS AND HELPERS AT LEAST 50 FEET (15 METERS) AWAY FROM THE OPERATOR AND UNIT. STOP THE ENGINE IF YOU ARE APPROACHED. IN AREAS WHERE OTHER PEOPLE AND ANIMALS ARE PRESENT, SUCH AS NEAR SIDEWALKS, STREETS, HOUSES, ETC., IT IS STRONGLY RECOMMENDED THAT THE OPERATOR USE THE BUDDY SYSTEM; THAT IS, HAVE ANOTHER PERSON SERVE AS A "LOOK-OUT," KEEPING HIMSELF AND OTHERS AT LEAST 50 FEET (15 METERS) AWAY FROM THE OPERATOR.

SEMI-AUTOMATIC HEAD PARTS THAT ARE CHIPPED, CRACKED OR DAMAGED IN ANY OTHER WAY CAN FLY APART AND CAUSE SERIOUS INJURY. DO NOT USE. REPLACE DAMAGED PARTS BEFORE USING THE UNIT.

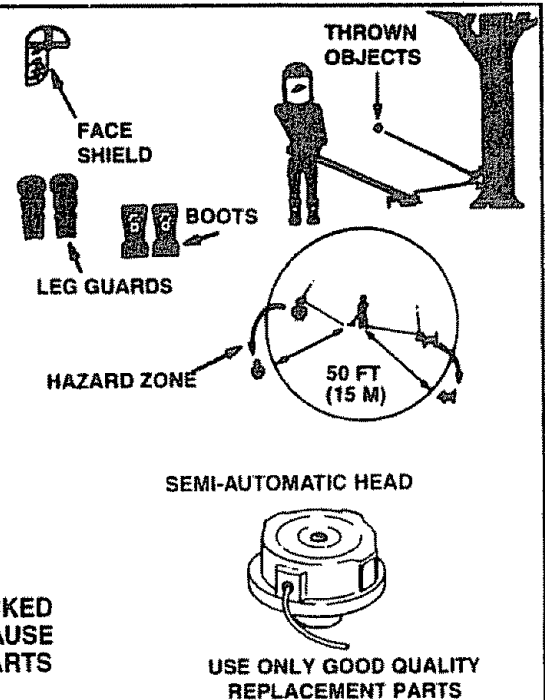

### OPERATOR SAFETY

- Always wear eye protection when operating, servicing, or performing maintenance on your unit. Refer to "Accessories".
- Do not operate this unit when you are tired, ill, or under the influence of alcohol, drugs or medication.
- Always wear heavy, long pants, long sleeves, boots, and gloves. Do not go barefoot, wear sandals, or short pants. Loose clothing, jewelry or clothing with loosely hanging straps, ties, tassels, etc. can be caught in moving parts. Secure hair so it is above shoulder length. Being fully covered will help protect you from pieces of toxic plants such as poison ivy thrown by the semi-automatic head, which could be more of a hazard than touching the plant itself.
- Do not swing the unit with such force that you are in danger of losing your balance.
- Never start or run the engine inside a closed room or building. Breathing exhaust fumes can kill.
- Keep handles free of oil and fuel.

### UNIT SAFETY

- Inspect the entire unit before each use. Replace damaged parts. Check for fuel leaks and make sure all fasteners are in place and securely fastened.
- Use only .080" diameter good quality monofilament line. Never use wire, rope, or string, etc.
- Be sure the plastic debris shield is properly attached.
- Make sure semi-automatic head is properly installed and securely fastened. Refer to "Assembly".
- Make carburetor adjustments with the drive shaft housing supported to prevent the semi-automatic head from contacting any object.
- Keep others away when making carburetor adjustments.
- Use only good quality SEARS accessories or attachments.

### CUTTING SAFETY

- Inspect the area to be cut before each use. Remove objects (rocks, broken glass, nails, wire, string, etc.) which can be thrown or become entangled in the semi-automatic head.
- Always keep the engine on the right side of your body.
  - Hold the unit firmly with both hands.
  - Keep firm footing and balance. Do not over-reach.
  - Keep the semi-automatic head below waist level.
  - Do not raise the engine above your waist.
  - Keep all parts of your body away from the semi-automatic head and muffler when engine is running.
  - Use only for jobs explained in this manual.
  - Cut at full throttle.
  - Cut from your right to your left.

# OPERATION

## LINE TRIMMER OPERATING TIPS (Fig. 10)



### WARNING:

USE MINIMUM SPEED AND DO NOT CROWD THE LINE WHEN CUTTING AROUND HARD OBJECTS (ROCK, GRAVEL, FENCE POSTS, ETC.) WHICH CAN DAMAGE THE SEMI-AUTOMATIC HEAD, BECOME ENTANGLED IN THE LINE, OR BE THROWN CAUSING A SERIOUS HAZARD.

ALWAYS WEAR EYE PROTECTION. NEVER LEAN OVER THE SEMI-AUTOMATIC HEAD. ROCKS OR DEBRIS CAN RICOCHET OR BE THROWN INTO EYES AND FACE AND CAUSE BLINDNESS OR OTHER SERIOUS INJURY.

- For trimming or scalping, use partial throttle to increase line life, especially:
  - during light duty cutting.
  - near objects around which the line can wrap or wear line such as small posts, trees, fence wire or concrete
- The line will easily remove grass and weeds from around walls, fences, trees and flower beds; but, it also can cut the tender bark of trees or shrubs and scar fences. To help avoid damage especially to delicate vegetation or trees with tender bark, shorten line to 4-5 inches and use at partial throttle
- The tip of the line does the cutting. You will achieve the best performance and minimum line wear by not crowding the line into cutting area.
- Always release throttle trigger and allow engine to return to idle speed when not cutting.
- Hold bottom of the semi-automatic head about 3 inches above ground and at an angle.

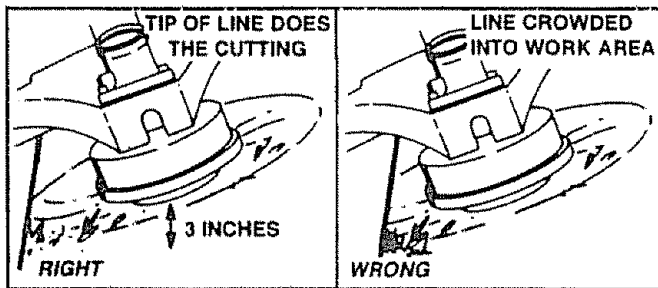

Figure 10

## TECHNIQUES (Fig. 11, 12, 13 & 14)

- **TRIMMING** – Allow only the tip of the line to make contact. Do not force trimmer line into work area.

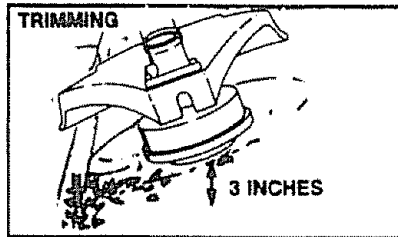

Figure 11

### REMEMBER

Keep semi automatic head 3 inches above the ground while trimming.

- **SCALPING** – The scalping technique removes unwanted vegetation. Allow the tip of the line to strike the ground around trees, post, monuments, etc. *This technique increases line wear.*

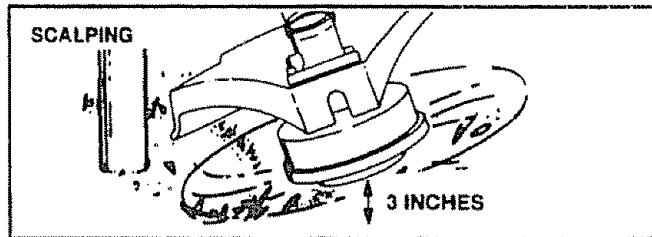

Figure 12

- **MOWING** – Your trimmer is ideal for mowing in places conventional lawn mowers cannot reach. Keep the line parallel to the ground.

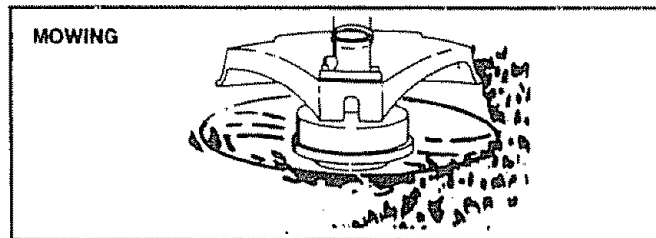

Figure 13

- **SWEEPING** – The fanning action of the rotating line can be used for a quick and easy clean up. Keep the line parallel to and above the surfaces being swept and move unit from side to side.

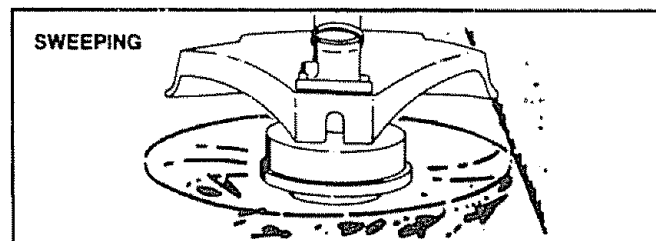

Figure 14

# CUSTOMER RESPONSIBILITIES

## MAINTENANCE SCHEDULE

Fill in dates as you complete regular service	Before Use	After Use	Every 5 Hrs.	Every 25 Hrs.	Yearly	Service Dates				
Check for damaged or worn parts	✓									
Check for loose fasteners & parts	✓									
Clean unit & labels		✓								
Clean air filter			✓							
Clean/Inspect Spark Arrestor Screen (if installed) and Muffler				✓						
Drive Shaft Lubrication				✓						
Replace spark plug					✓					
Replace fuel filter					✓					
Check gearbox lubrication					✓					

## GENERAL RECOMMENDATIONS

The warranty on this unit does not cover items that have been subjected to operator abuse or negligence. To receive full value from the warranty, the operator must maintain unit as instructed in this manual.

Some adjustments will need to be made periodically to properly maintain your unit.

All adjustments in the "Service and Adjustments" section of this manual should be checked at least once each season.

- Once a year, replace the spark plug, replace air filter element and check semi-automatic head for wear. A new spark plug and a clean or new air filter element assures proper air-fuel mixture and helps your engine run better and last longer.
- Follow the maintenance schedule in this manual.



### WARNING

**DISCONNECT THE SPARK PLUG BEFORE PERFORMING MAINTENANCE EXCEPT FOR CARBURETOR ADJUSTMENTS.**

**REPLACE SEMI-AUTOMATIC HEAD PARTS THAT ARE CRACKED, CHIPPED, OR DAMAGED IN ANY OTHER WAY BEFORE USING THE UNIT.**

**INSPECT THE ENTIRE UNIT. REPLACE DAMAGED PARTS. CHECK FOR FUEL LEAKS AND MAKE SURE ALL FASTENERS ARE IN PLACE AND SECURELY FASTENED.**

## BEFORE USE

### CHECK FOR DAMAGED OR WORN PARTS

- Semi-automatic head – replace semi-automatic head parts that are bent, warped, cracked, or damaged in any way.
- Fuel cap – replace broken or leaking fuel cap.
- Debris shields – replace debris shields that are bent, warped, cracked, or damaged in any way.
- Line limiter – missing or damaged.

### CHECK FOR LOOSE FASTENERS AND PARTS

- Semi-automatic head
- Assist handle
- Throttle handle
- Cylinder and muffler cover
- Air filter cover
- Muffler
- Line Limiter

## AFTER USE

### CLEAN UNIT AND LABELS

- Clean the unit using a damp cloth with a mild detergent after use.
- Wipe off the unit with a clean dry cloth.

## LUBRICATION CHART

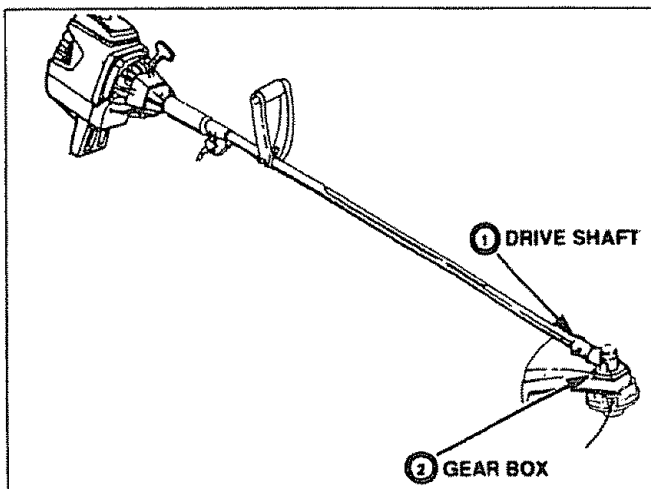

- ① General purpose lithium base grease.
- ② General purpose lithium base grease.

# CUSTOMER RESPONSIBILITIES

## EVERY 5 HOURS CLEAN AIR FILTER (Fig. 15)

A dirty air filter decreases the life and performance of the engine and increases fuel consumption and harmful emissions.

Always clean after 5 tanks of fuel or 5 hours of operation. Clean more frequently in dusty conditions.

- Loosen the screws on the air filter cover enough to remove the cover from the engine.
- Remove air filter from cover.
- Clean the air filter using hot soapy water. Rinse with clean cool water. Squeeze air filter dry and replace in cover
- Re-install the air filter cover, making sure the choke exit slot is placed over the choke lever.

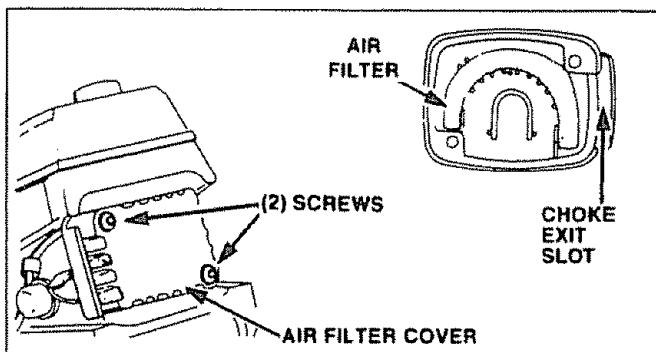

Figure 15

## EVERY 25 HOURS CLEAN AND INSPECT SPARK ARRESTOR SCREEN (Fig. 16)

As the unit is used, carbon deposits build up on the muffler and spark arrestor screen (if installed), and must be removed to avoid creating a fire hazard or affecting engine performance.

Required cleaning is every 25 hours of operation or annually, whichever is less.

Replace the spark arrestor screen if breaks occur.

### CLEANING THE SPARK ARRESTOR SCREEN

- Loosen and remove the 2 muffler guard screws.
- Remove the muffler guard.
- Remove the muffler cover retaining springs.
- Remove muffler diffuser and spark arrestor screen assembly. Notice the orientation of these parts for reassembly.
- Clean the spark arrestor screen with a wire brush or replace if breaks are found in the screen.
- Replace any broken or cracked parts.
- Reinstall diffuser and spark arrestor screen assembly.
- Reinstall muffler cover and the two muffler cover retaining springs.
- Reinstall muffler guard and the two muffler guard screws (15-20 in lbs).

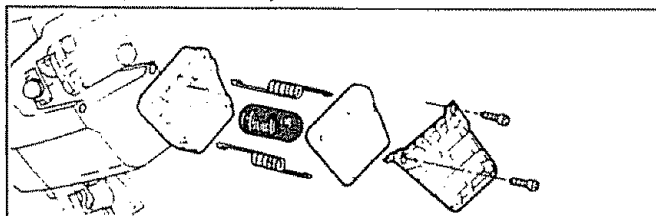

Figure 16

## DRIVE SHAFT LUBRICATION (Fig. 17)

- Loosen the gear box clamp screw and the locating screw from the gear box.
- Remove the gear box from the tube.
- Remove the drive shaft from the tube.
- Check drive shaft for broken wires, twists or kinks, and replace if damage is found.
- Using a clean cloth, wipe surface of drive shaft thoroughly to remove any grease or dirt
- Apply a uniform coat of lithium base grease to the entire surface of the drive shaft.
- Inject the remaining contents of the grease tube into the top of the tube.
- Replace drive shaft in the tube.
- Re-assemble the gear box to the tube. Tighten screws securely.

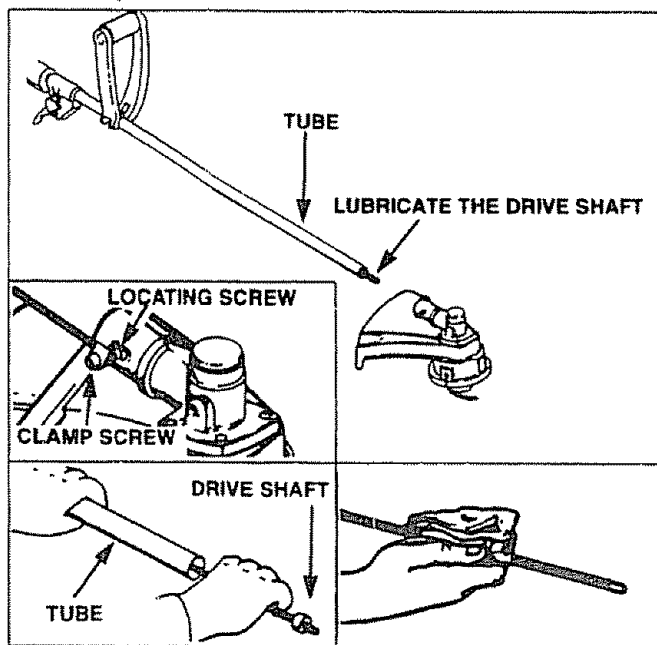

Figure 17

## YEARLY REPLACE SPARK PLUG (Fig. 18)

The spark plug should be replaced each year to ensure the engine starts easier and runs better. Spark plug gap should be .025".

- Twist, then pull off spark plug boot.
- Remove spark plug from cylinder and discard.
- Replace with correct spark plug and re-tighten with spark plug wrench (10-12 ft.lb.)
- Reconnect spark plug boot.

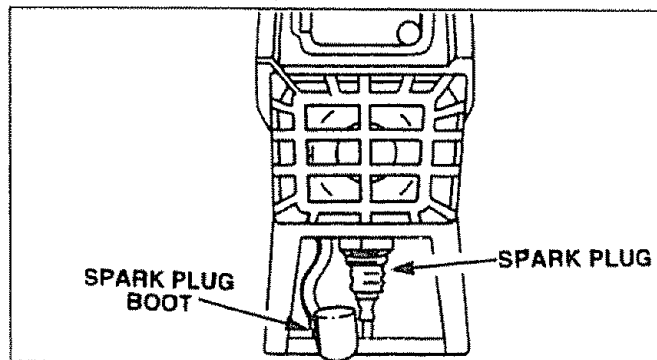

Figure 18

## CUSTOMER RESPONSIBILITIES

### REPLACE FUEL FILTER (Fig. 19 & 20)

- Run fuel tank dry of fuel before proceeding with this step.
- Remove fuel cap and allow it to hang to side of motor.
- Using a small pair of needle nose pliers, grasp fuel cap retainer, holding it in tank opening and pull out.
- With cap out of tank, use a small section of bent wire similar to that shown in the illustration to catch fuel line and slowly pull from tank. When fuel filter appears in opening, grasp with fingers and remove from tank.
- Once filter is out of tank, hold fuel line close to fuel filter. Remove fuel filter by twisting and pulling at the same time.
- Replace fuel filter.
- Reverse process for installation.

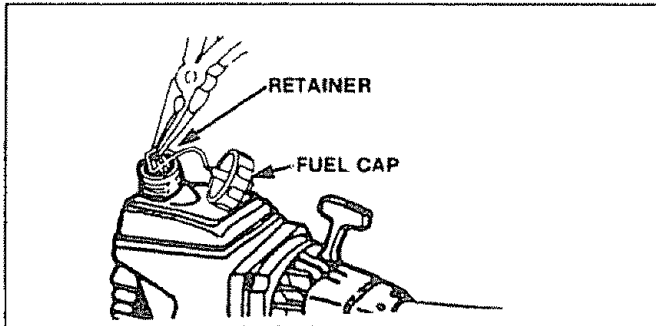

Figure 19

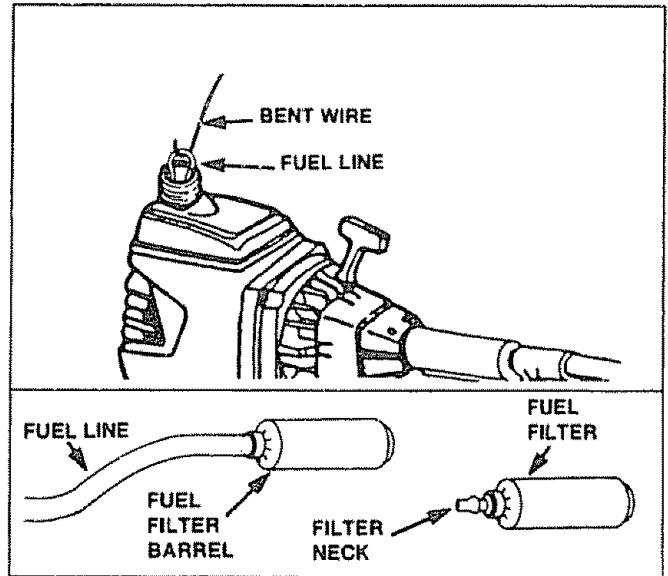

Figure 20

### GEAR BOX LUBRICATION (Fig. 21)

- Remove the gear box screw using a wrench.
- Fill gear box with lithium base gear grease.
- Replace and tighten gear box screw securely.

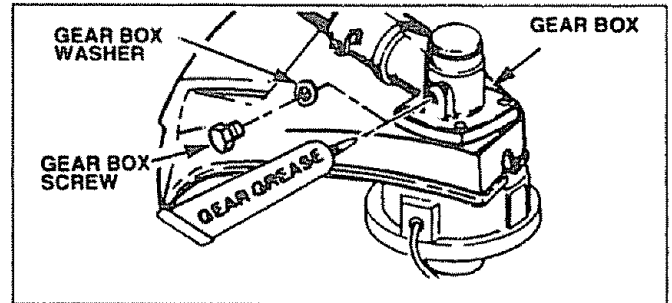

Figure 21

# SERVICE AND ADJUSTMENTS

## STARTER ROPE (Fig. 22, 23 & 24)



**DANGER:**  
DO NOT REMOVE THE RETAINING TAB AND SCREW OR THE PULLEY. THE SPRING BENEATH THE PULLEY IS UNDER TENSION AND CAN FLY OUT AND CAUSE SERIOUS INJURY. IF ANY PART OF PULLEY HOUSING ASSEMBLY IS DAMAGED (OTHER THAN ROPE), DO NOT USE UNIT. TAKE IT TO YOUR SEARS SERVICE CENTER/DEPARTMENT.

- Disconnect spark plug wire
- Remove the screw and nut from the throttle trigger housing.
- Hold throttle trigger away from the foam grip and remove the barrel end of the throttle cable from the throttle trigger.
- Carefully pull throttle cable out of foam grip.
- Loosen nose cone screws.
- Remove tube from nose cone
- Remove front shroud screws
- Separate nose cone from engine
- If any old rope remains on unit, cut rope at starter handle to release tension.
- Remove the rope retainer screw and remove any remaining rope
- Turn pulley clockwise as far as it will go. Then, turn the pulley counterclockwise until the pulley notch is aligned with the housing notch. Next, turn the pulley one complete turn counterclockwise until the notches are aligned again.
- Insert the long hex key into the hole formed by the notches to hold the pulley in position.
- Use a 42" length of replacement rope
- Move away 10 feet (3 meters) from the fuel tank with the replacement rope. Use a match and melt both ends of the rope to prevent fraying.
- Insert one end of rope through handle and secure with a knot. Leave a 3/16" pigtail behind knot.
- Insert the other end of the rope through the rope exit hole into the inside of the housing, into the pulley and up through the pulley hole.
- Wrap rope counterclockwise around the pulley ratchet and tuck loose end under rope where it comes out of the pulley hole. Leave a 1" tail laying flat on top of the pulley *between* the retainer rib and the retainer screw/post
- Install the rope retainer screw in the screw post.
- Pull firmly on the rope to tighten it against the pulley ratchet. The rope tail *must not* extend beyond the raised circle on the pulley to prevent interference with the retaining tab.
- Hold rope taut at rope exit hole so it will not move; remove long hex key.
- Slowly feed rope into the pulley housing.
- To reassemble, reverse the above steps.

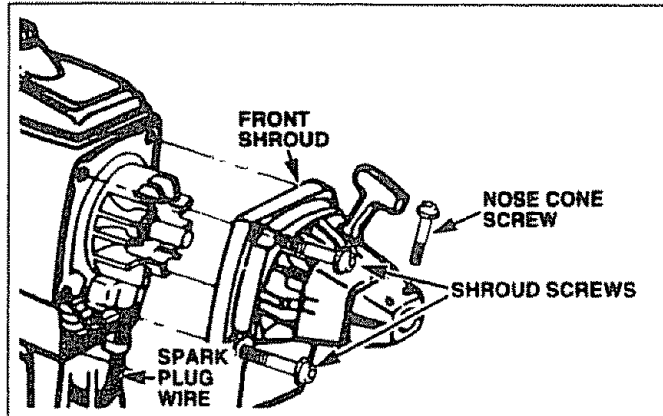

Figure 22

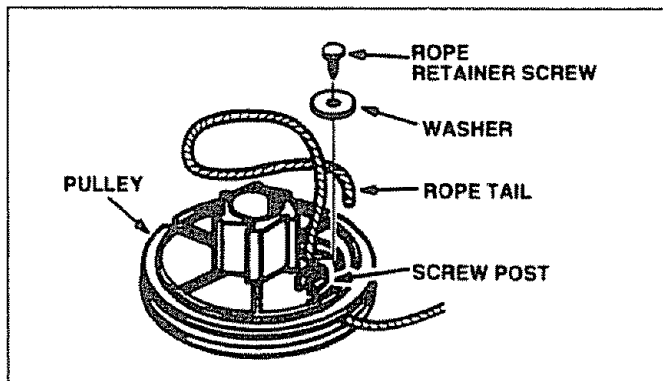

Figure 23

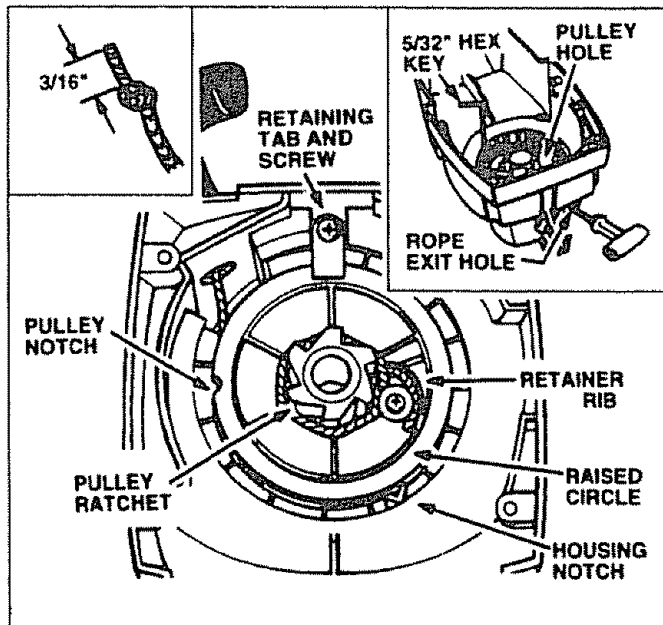

Figure 24

# SERVICE AND ADJUSTMENTS

## TRIMMER LINE REPLACEMENT



**WARNING:**  
SEMI-AUTOMATIC HEAD PARTS THAT ARE CHIPPED, CRACKED, BROKEN, OR DAMAGED IN ANY OTHER WAY CAN FLY APART AND CAUSE SERIOUS INJURY. DO NOT USE. REPLACE DAMAGED PARTS BEFORE USING THE UNIT.

THE LINE SAVER MUST BE INSTALLED ONLY FROM THE INSIDE OF THE SEMI-AUTOMATIC HEAD. IF INSTALLED ON THE OUTSIDE OF THE SEMI-AUTOMATIC HEAD, THE LINE SAVER CAN FLY OFF AND BECOME A DANGEROUS MISSILE.

USE ONLY .080" DIAMETER GOOD QUALITY LINE. NEVER USE WIRE, ROPE, STRING, ETC.

USE ONLY SPECIFIED SEARS REPLACEMENT PARTS. USE OF OTHER BRANDS OF REPLACEMENT PARTS CAN CAUSE DAMAGE TO YOUR UNIT OR INJURY TO THE OPERATOR OR OTHERS. DAMAGE/INJURY CAUSED BY USE OF ACCESSORIES/ATTACHMENTS NOT SPECIFICALLY RECOMMENDED BY SEARS WILL NOT BE REIMBURSED.

**IMPORTANT:** ALWAYS CLEAN DIRT AND DEBRIS FROM SPOOL AND HUB WHEN PERFORMING ANY TYPE MAINTENANCE.

## INSTALLING PRE-WOUND SPOOL (Fig. 25, 26, 27, 28, 29 & 30)

- Hold the semi-automatic head as shown. Press the two lock tabs and remove cover. Figure 25
- Remove the empty spool. Refill or use a pre-wound replacement spool.
- Clean dirt and debris from all parts. Replace the spool when the square corners on the lugs are rounded off, reduced in size, or broken off. Figure 26
- Catch the line in the notch in the spool. Leave about 4 inches of line hanging from the spool. Insert the end of the line in the line exit hole. Figure 27.
- Align the line and notch with the line exit hole. Place spool in hub. Make sure trimmer line is not caught between the rim of the spool and the hub.

**NOTE:** To set the spool in the hub, it may be necessary to pull the line through the line exit hole until the spool drops into place.

- Align the lock tabs on the cover over the catches on the hub. Push the cover down onto the hub until the parts snap together. Figure 28.
- Check to make sure the lock tabs are properly fastened as shown.
- Obtain the correct line length (6 inches) by pressing tap button and pulling on the line again. Figure 29.

**NOTE:** If tab button gets knocked out of the hub, reassemble parts as follows.

- Remove the cover and spool.
- Place the spring in the hub cylinder. Figure 30.

- Place the tap button over the spring and hub cylinder.
- Align the slots in the tap button with the fins in the base of the hub. Push parts together.
- Reinstall the spool and cover.

## INSTALLING NEW LINE ON SPOOL

To replace the line on existing spool:

- Follow "Installing Spool with Line Already Wound" steps and remove any line remaining on the spool.
- Use a 25 foot length of SEARS .080" diameter line.
- Insert about 1/4 inch of the end of the line through the hole in the inner rim of the spool. Allow no more than 1/4 inch of line to extend beyond the rim to avoid interference with tapping action. Figure 30.

- Wrap the line on the spool as shown by the arrow.

**NOTE:** The line must be wrapped firmly and evenly for proper line feed.

- Follow "Installing Spool with Line Already Wound" steps to complete assembly.
- If line breaks off or backs up in the semi-automatic head, follow "Installing Spool with Line Already Wound" steps. Pull slack in line until the line is tightly wound on spool, leaving 4-6 inches of extended line. Figure 30.

## INSTALLING THE SPOOL

- Insert line into line exit hole in the hub as shown. Figure 27.
- Align the notch with the line exit hole.
- Push spool into the hub until it snaps into place.
- Pull the end of the line to seat spool in hub.
- Reinstall the cover.

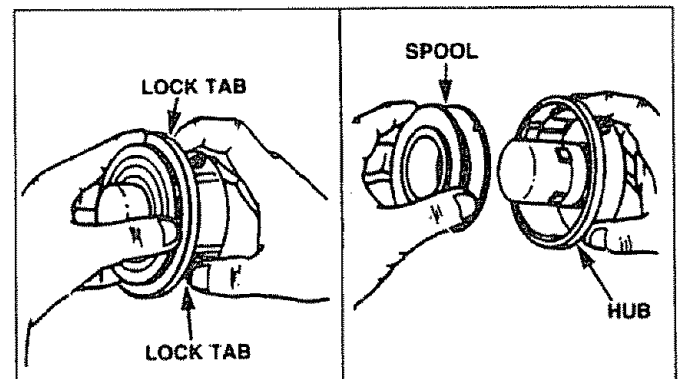

Figure 25

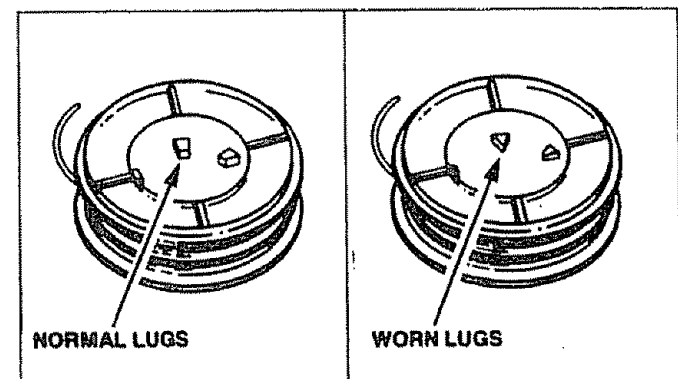

Figure 26

# SERVICE AND ADJUSTMENTS

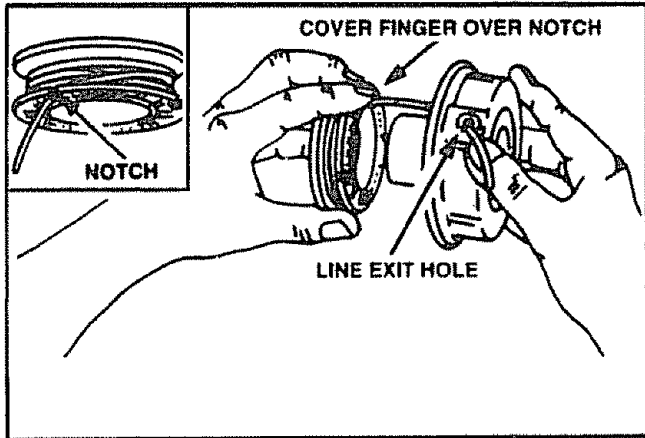

Figure 27

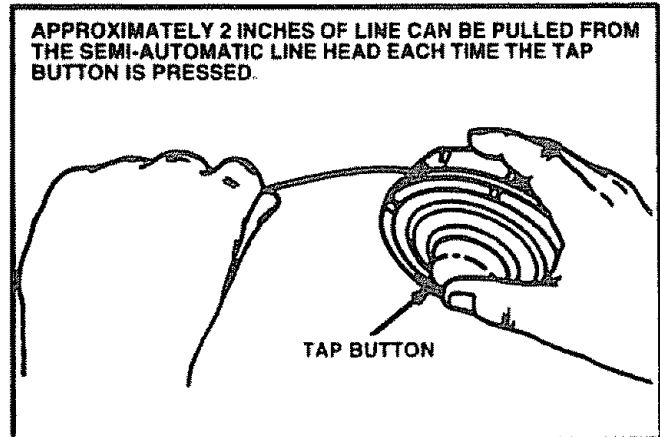

Figure 29

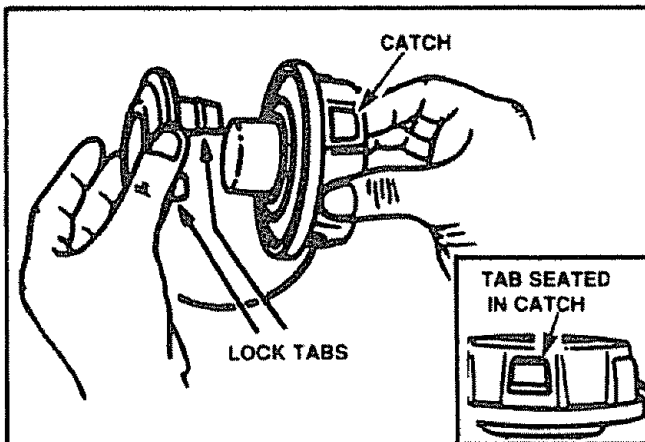

Figure 28

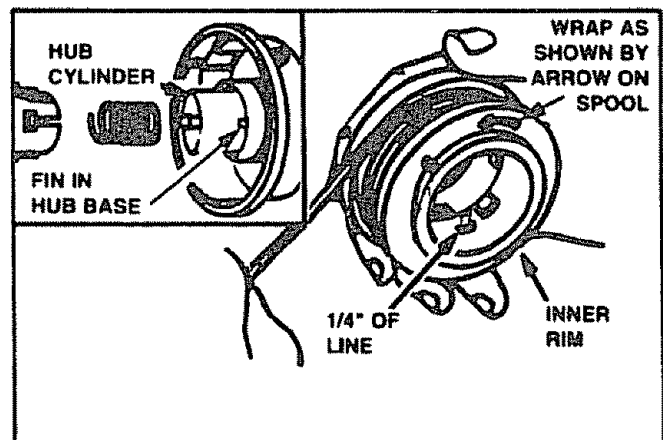

Figure 30

# SERVICE AND ADJUSTMENTS

Carburetor adjustment is critical and if done improperly can permanently damage the engine as well as the carburetor. Please read all instructions and consult the Troubleshooting section of this manual before beginning this process. If the engine does not operate according to these instructions after repeating the adjusting steps, do not use the unit. For further assistance, please call our customer assistance hotline at 1-800-235-5878.



**WARNING:**  
MAKE CARBURETOR ADJUSTMENTS WITH THE LOWER END SUPPORTED TO PREVENT SEMI-AUTOMATIC HEAD FROM CONTACTING ANY OBJECT. HOLD UNIT WITH YOUR HAND.

THE SEMI-AUTOMATIC HEAD WILL BE SPINNING DURING MOST OF THIS PROCEDURE. WEAR YOUR PROTECTIVE EQUIPMENT AND OBSERVE ALL SAFETY PRECAUTIONS.

IN MIXTURE ADJUSTMENT, RECHECK IDLE SPEED AFTER EACH ADJUSTMENT.

If engine does not start, it may be flooded. If in doubt read the section on flooded engine in the starting section of this manual prior to beginning any adjustments.

The carburetor has been adjusted at the factory for sea level conditions. Adjustments may become necessary if the unit is used at significantly higher altitudes or if you notice any of the following conditions:

- Engine will not idle. See "Idle Speed Adjustment" and "Mixture Speed Adjustment".
- Engine dies or hesitates when it should accelerate. See "Acceleration Check".
- Loss of cutting power which is not corrected by air filter cleaning. See "Mixture Speed Adjustment".

**NOTE:** There are two adjustments on the carburetor.

- The Idle Speed Adjustment.
- The Mixture Adjustment.

## CARBURETOR PRESETS (Fig. 31)

If your engine will not start due to suspected improper carburetor adjustment, the following presets may be required. If used, it is recommended that all steps within the adjustment procedure be completed in order to assure a properly set carburetor. If presets are not needed, proceed to section "Idle Speed Adjustment".

Very small adjustments can affect engine performance. It is important to make slight adjustments and test performance before proceeding. Each adjustment should be no more than 1/16th of a turn.

- Turn the mixture adjustment fully counterclockwise to the limiter cap stops.
- Turn idle speed adjustment clockwise one full turn.
- If engine fails to start after performing carburetor presets, the unit may be flooded. Review the "Difficult Starting" section of the manual. If problems continue, call the 1-800 number listed on the front cover of this manual for further assistance.

- Start the engine and operate for three (3) minutes to warm up. Go to "Adjusting Procedure".

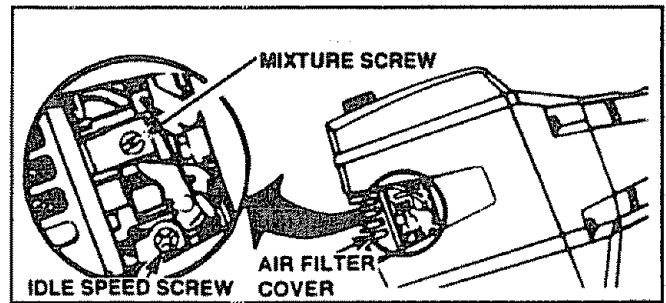

Figure 31

## ADJUSTING PROCEDURE IDLE SPEED ADJUSTMENT

- Allow the warm engine to idle.
- Adjust the Idle Speed until the engine continues to run without stalling.
  - Turn screw clockwise to increase engine speed if engine stalls or dies.
  - Turn screw counterclockwise to slow engine down.
- Follow instructions in "Acceleration Check".
- No further adjustments are necessary if performance is satisfactory.

## MIXTURE ADJUSTMENT

- Support the lower end so the semi-automatic head is off the ground and will not make contact with any object. Be sure the trimmer line is extended to the maximum length allowed by the line limiter.
- Start the engine. Allow engine to idle, then squeeze throttle trigger fully.
- NOTE:** Perform steps below at full throttle.
- Turn mixture screw counterclockwise to the limiter cap stop.
- Run engine at full throttle for 30 seconds.
- If engine is running rough, turn mixture screw clockwise in 1/16th turn increments until engine just starts to run smoothly.
- Do not attempt to adjust screw beyond stops as damage will occur.
- After completing adjustments, check for acceleration.
- If the unit accelerates and runs smoothly, no further adjustments are necessary. If not, proceed to "Acceleration Check".

## ACCELERATION CHECK

- Allow engine to idle.
- Squeeze trigger fully
  - If performance is satisfactory (engine accelerates smoothly), no further adjustments are necessary.
  - If the engine does not accelerate smoothly, turn the mixture screw counterclockwise a small amount (no more than the width of the slot in the adjusting screw).
- Repeat step above until smooth acceleration is obtained. Do not attempt to adjust the screw beyond the stop as damage will occur.

**NOTE:** It may be necessary to repeat "Idle speed Adjustment" through "Acceleration Check," to obtain correct adjustments.

# STORAGE

Immediately prepare your unit for storage at the end of the season or if it will not be used for 30 days or more.



**WARNING:**  
**ALLOW THE ENGINE TO COOL, AND SECURE THE UNIT BEFORE STORING OR TRANSPORTING IN A VEHICLE.**

**STORE UNIT AND FUEL IN AN AREA WHERE FUEL VAPORS CANNOT REACH SPARKS OR OPEN FLAMES FROM WATER HEATERS, ELECTRIC MOTORS OR SWITCHES, FURNACES, ETC.**

**STORE UNIT WITH ALL GUARDS IN PLACE. POSITION SO THAT ANY SHARP OBJECT CANNOT ACCIDENTALLY CAUSE INJURY TO PASSERS BY.**

**STORE THE UNIT OUT OF THE REACH OF CHILDREN.**

## GAS TRIMMER STORAGE INSTRUCTIONS

If your trimmer is to be stored for a period of time, clean it thoroughly prior to storage. Remove any dirt, leaves, oil, grease, etc. Store in a clean dry area.

- Clean the entire unit
- Clean air filter. Refer to "Customer Responsibilities."
- Open the semi-automatic head assembly and clean any dirt, grass or debris that has collected.
- Inspect the cutting line. Old cutting line may be chalky or sticky to the touch. Remove and discard old line and install fresh new line.
- Lightly oil external metal surfaces to prevent rust from forming.
- Re-assemble all loose parts, being sure that all handles and guards are in place and are securely fastened. Replace any damaged parts.
- The recommended storage position is either vertically with the fuel cap on top, or horizontally with the fuel cap up. **Do not store unit with the cutting attachment up.**
- Hang the unit by the brackets under the motor housing to avoid fuel leaks. Make sure the unit is positioned so that the line limiter cannot cause injury.



**CAUTION: WEAR PROTECTIVE GLOVES WHEN HANDLING LINE LIMITER. THE BLADE IS SHARP AND CAN CUT YOU.**

## FUEL SYSTEM

Never use engine or carburetor cleaner products in the fuel tank or permanent damage may occur to fuel system components. Follow these instructions:

- Drain the fuel from the unit into an approved fuel container.
- Drain the fuel lines and carburetor by starting the engine and letting it run until it stops.
- Allow the engine to cool before storage

**IMPORTANT:** It is important to prevent gum deposits from forming in essential fuel system parts such as the carburetor, fuel filter, fuel hose or tank during storage. Also, experience indicates that alcohol blended fuels, those that use ethanol or methanol (called gasohol or oxygenated fuel), can attract moisture and form acidic gas which will damage your engine. To avoid engine problems, the fuel system should be emptied before storage of 30 days or longer.

Fuel stabilizer is an acceptable alternative in minimizing the formation of fuel gum deposits during storage. Add stabilizer to the gasoline in the fuel tank or fuel storage container. Always follow the mix instructions found on stabilizer containers. Run engine at least 5 minutes after adding stabilizer to allow the stabilizer to reach the carburetor.

CRAFTSMAN 40:1 2-cycle engine oil (AIR-COOLED) is specially blended with fuel stabilizer. If you do not use this Sears oil, you can add a fuel stabilizer (such as CRAFTSMAN No. 33500) to your fuel tank.

## INTERNAL ENGINE

- Remove spark plug and pour 1 teaspoon of 40:1 2-cycle engine oil (AIR-COOLED) through the spark plug opening. Slowly pull the starter rope 8 to 10 times to distribute oil to inner engine surfaces.
- Replace spark plug with a new one of the recommended type and heat range. Refer to "Product Specifications."
- Clean air filter. Refer to "Customer Responsibilities."
- Re-install all covers and hardware removed for access; tighten all screws and fasteners.
- Check entire unit for loose screws, nuts, and bolts. Replace any damaged, broken, or worn parts.
- Lightly oil external metal surface to prevent rust from forming.
- Use fresh fuel having the proper gasoline to oil ratio at the beginning of the next season.

## OTHER

- Do not store gasoline from one season to another.
- Replace your gasoline can if your can starts to rust. Rust and/or dirt in your fuel system will cause problems.
- Store your unit in a well ventilated area and covered, if possible, to prevent dust and dirt accumulation. Do not cover with plastic. Plastic cannot breathe and will induce condensation and eventual rust or corrosion.

**IMPORTANT: NEVER COVER UNIT WHILE ENGINE AND EXHAUST AREAS ARE STILL WARM.**

# TROUBLE SHOOTING POINTS

## TROUBLE SHOOTING CHART

SYMPTOM	CAUSE	CORRECTION
Engine will not start or will run only for a few seconds after starting.	<ol style="list-style-type: none"> <li>1. Fuel tank empty.</li> <li>2. Engine flooded.</li> <li>3. Spark plug not firing.</li> <li>4. Fuel not reaching carburetor.</li> <li>5. Carburetor requires adjustment.</li> <li>6. None of the above.</li> </ol>	<ol style="list-style-type: none"> <li>1. Fill tank with correct fuel mixture.</li> <li>2. See "Starting Instructions".</li> <li>3. Install new plug/check ignition switch.</li> <li>4. Replace fuel filter; inspect fuel line.</li> <li>5. See "Carburetor Adjustments."</li> <li>6. Contact your SEARS Service Center/Dept.</li> </ol>
Engine will not idle properly.	<ol style="list-style-type: none"> <li>1. Carburetor set too fast or too slow.</li> <li>2. Carburetor requires adjustment.</li> <li>3. None of the above.</li> </ol>	<ol style="list-style-type: none"> <li>1. See "Carburetor Adjustments."</li> <li>2. See "Carburetor Adjustments."</li> <li>3. Contact your SEARS Service Center/Dept.</li> </ol>
Engine will not accelerate, lacks power, or dies under a load.	<ol style="list-style-type: none"> <li>1. Air filter dirty.</li> <li>2. Spark plug fouled.</li> <li>3. Carburetor requires adjustment.</li> <li>4. Muffler outlets plugged.</li> <li>5. None of the above.</li> </ol>	<ol style="list-style-type: none"> <li>1. Clean or replace air filter.</li> <li>2. Clean or replace spark plug and re-gap.</li> <li>3. See "Carburetor Adjustments."</li> <li>4. Contact your SEARS Service Center/Dept.</li> <li>5. Contact your SEARS Service Center/Dept.</li> </ol>
Engine smokes excessively.	<ol style="list-style-type: none"> <li>1. Air filter dirty.</li> <li>2. Fuel mixture incorrect.</li> <li>3. Carburetor requires adjustment.</li> </ol>	<ol style="list-style-type: none"> <li>1. Clean or replace air filter.</li> <li>2. Refuel with correct fuel mixture.</li> <li>3. See "Carburetor Adjustments."</li> </ol>
Engine runs hot	<ol style="list-style-type: none"> <li>1. Fuel mixture incorrect.</li> <li>2. Spark plug incorrect.</li> <li>3. Carburetor set too high (lean).</li> <li>4. Wrong diameter cutting line. (too large)</li> <li>5. None of the above.</li> </ol>	<ol style="list-style-type: none"> <li>1. See "Fueling Your Unit."</li> <li>2. Replace with correct plug.</li> <li>3. See Carburetor Adjustments."</li> <li>4. Use only .080" diameter cutting line.</li> <li>5. Contact your SEARS Service Center/Dept.</li> </ol>
Semi-automatic head stops under a load or does not turn when engine is accelerated.	<ol style="list-style-type: none"> <li>1. Drive shaft not engaged.</li> <li>2. Drive shaft broken.</li> </ol>	<ol style="list-style-type: none"> <li>1. See "Assembly," "Tube", insert fully.</li> <li>2. Contact your SEARS Service Center/Dept.</li> </ol>
Line does not advance or breaks while cutting.	<ol style="list-style-type: none"> <li>1. Line improperly routed in head.</li> <li>2. Line improperly wound onto spool.</li> <li>3. Line size incorrect.</li> <li>4. Old cutting line.</li> <li>5. Too little line outside head.</li> <li>6. Dirt accumulated in cover.</li> <li>7. Line wound in wrong direction.</li> </ol>	<ol style="list-style-type: none"> <li>1. Remove cover. Check line routing.</li> <li>2. Rewind line tightly and evenly.</li> <li>3. Use only .080" diameter line.</li> <li>4. Replace with new cutting line.</li> <li>5. Remove cover. Pull 4" of line to outside.</li> <li>6. Clean cover.</li> <li>7. Rewind in correct direction.</li> </ol>
Line welds onto spool.	<ol style="list-style-type: none"> <li>1. Line size incorrect.</li> <li>2. Old cutting line.</li> <li>3. Incorrect spool.</li> <li>4. Crowding line against material being cut.</li> </ol>	<ol style="list-style-type: none"> <li>1. Use only .080" diameter line.</li> <li>2. Replace with new cutting line.</li> <li>3. Use proper spool.</li> <li>4. Cut with tip of line.</li> </ol>
Line pulls back into head.	<ol style="list-style-type: none"> <li>1. Too little line outside of head.</li> <li>2. Old cutting line.</li> </ol>	<ol style="list-style-type: none"> <li>1. Remove cover. Pull 4" of line to outside.</li> <li>2. Replace with new cutting line.</li> </ol>

*If situations occur which are not covered in this manual, use care and good judgement.  
If you need assistance, contact your SEARS Service Center/Department or the  
CUSTOMER ASSISTANCE HOTLINE AT 1-800-235-5878.*