

SENCOR®

SHB 5610RS
SHB 5612WP



HAND BLENDER

Translation of the original manual



SENCOR®

SHB 5610RS
SHB 5612WP



A

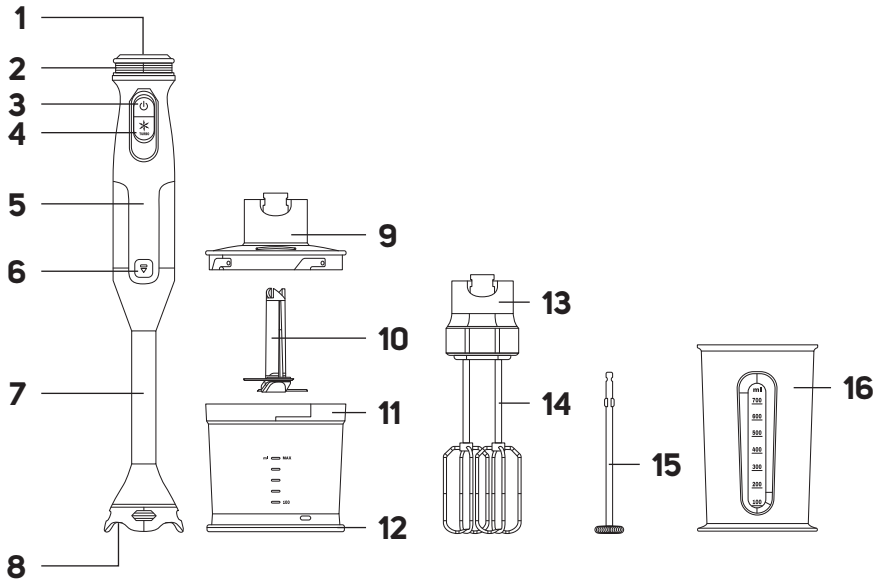

B

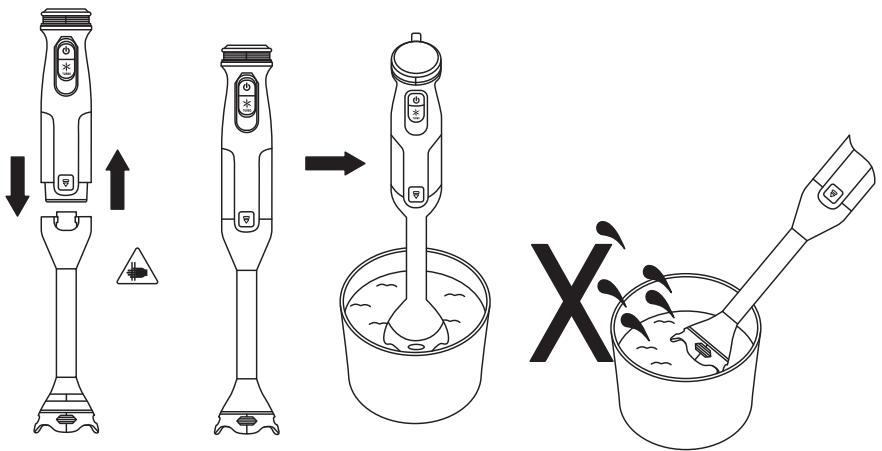

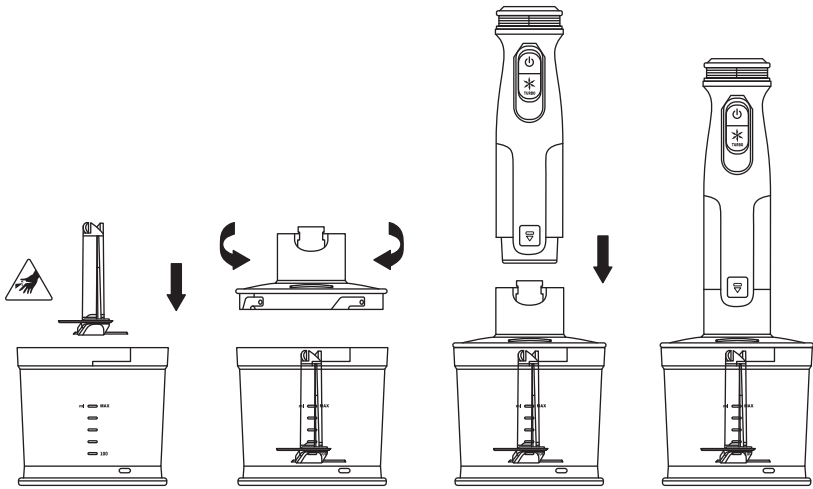
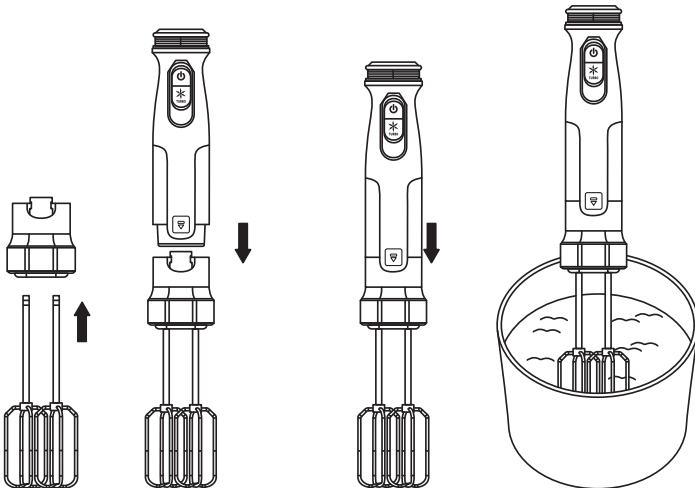
C**D**

E

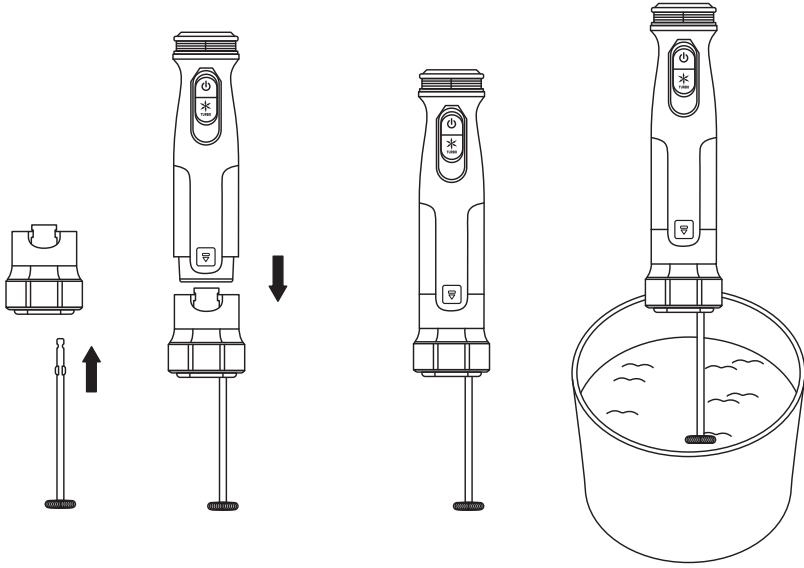

IMPORTANT SAFETY INSTRUCTIONS

READ CAREFULLY AND STORE FOR FUTURE USE.

- This appliance is not to be used by children. Keep this appliance and its power cable out of the reach of children.
- The appliance may be used by persons with reduced physical, sensory or mental abilities or lack of experience and knowledge, provided they are supervised or have been instructed on the safe use of the appliance and understand the potential hazards.
- Children must not play with the appliance.
- Cleaning and maintenance must not be carried out by children.
- If the power cable is damaged, have it replaced in a professional service centre in order to prevent a dangerous situation. Never use the appliance if the power cable is damaged.



WARNING!

Incorrect use may lead to injuries.

- Pay attention when handling the chopping blades, especially when removing the blades from the container, emptying the container and during cleaning.
- When cleaning food contact surfaces, follow the instructions in this manual. Use only clean water with a little neutral dishwashing detergent.

- Always disconnect the appliance from the power socket if you are leaving it unattended and before assembly, disassembly or cleaning.
 - Before replacing the accessories or accessible movable parts, please turn the appliance off and disconnect it from the power supply.
-

Additional Important Safety Instructions for Use of the Appliance

- Before connecting this appliance to a power socket, make sure the rated voltage stated on the product's rating label corresponds to the voltage in your power socket.
- The appliance is designed for home use and is used for blending, chopping, grating and whisking food. Do not use it to process food that are too hard, such as ice cubes, nutmeg, etc.
- Do not use the appliance in an industrial environment or outdoors. Do not use it for any other purposes than those intended.
- Do not place the appliance on or near an electric or gas cooker, on the edge of a table or on an unstable surface. Only place the appliance on an even, dry and stable surface.
- Use the appliance only with the original accessories supplied with it.
- Make sure that the appliance is correctly assembled before putting it into operation.
- Do not touch rotating parts that are in motion during operation. Keep hair, jewellery or loose pieces of clothing away from rotating parts. Otherwise, injury may occur.
- Take extra care when handling hot liquids and food. Hot steam or splashing hot liquids and food may cause scalding. For increased safety, allow hot liquids and foods to cool to at least 45°C before mixing. Only the immersion attachment is intended for processing warm liquids and foods. Other accessories are intended for processing cooled or cold foods. Do not process frozen foods or liquids.
- To push ingredients through the filling tube, always use the supplied pusher. Never use your hands or other items.
- The operating time of the appliance is 1 minute. Allow it to cool for at least 3 to 5 minutes before turning it on again. If you are using the appliance to blend sticky or harder food, stop operation after 30 seconds.
- Do not turn on the appliance when it is empty. Incorrect use of the appliance may negatively affect its lifetime.
- Always turn off the appliance and disconnect it from the power socket if you will not be using it and if you will be leaving it without supervision, before assembly, disassembly, cleaning or moving it.
- Before disassembling the appliance into individual parts, make sure that the motor unit is switched off, disconnected from the mains socket and that the rotating parts have stopped.
- Take extra care when handling the grater, hand blender blade unit or chopper, especially when removing the grater or blade unit, emptying the container and cleaning to avoid injury from the blade.
- Do not submerge the motor unit and power cord in water or any other liquids, and do not wash these parts under running water.
- Ensure that the power plug contacts do not come into contact with moisture. Do not place heavy items on the power cord. Make sure the power cord does not hang over the edge of a table or that it does not touch a hot surface.
- Do not disconnect the appliance from the power socket by pulling on the power cord. This could damage the power cord or the socket. Disconnect the power cord from the power socket by pulling the plug. Do not use the appliance if it is not working properly or shows signs of damage.
- To prevent dangerous situations, do not repair or modify the appliance yourself. All repairs should be carried out by an authorised service centre. Tampering with the appliance may result in the loss of your legal rights regarding faulty performance or warranty for quality.

Prevention of Household Accidents

- Hot or boiling liquids pose a significant risk to children, and even minor burns can be serious. Observe basic household injury prevention rules and exercise increased caution when children are near hot or boiling liquids. If necessary, explain to children the risks associated with hot or boiling liquids.
 - In the event of burns or scalds, immediately rinse the affected area under a stream of cold water and seek medical assistance if required.
-

EXPLANATION OF SYMBOLS PLACED ON THE PRODUCT OR IN THE ACCOMPANYING DOCUMENTATION



The product meets all the basic requirements of the applicable EU directives.



This symbol on products or accompanying documents means that used electric or electronic products must not be added to ordinary municipal waste.



Product with protection class II
Protection against electric shock is ensured by double or reinforced insulation.

EN Hand Blender User Manual

- Thank you for purchasing our SENCOR product; we hope it will serve to your satisfaction.
- Prior to using this appliance, please read the user manual thoroughly, even in cases when you are already familiar with the use of similar types of appliances. Use the appliance only as described in this user manual. Keep the manual for future reference. If you pass the appliance on to another person, ensure that this user manual is included.
- Carefully unpack the appliance and make sure not to discard any part of the packaging material until you have removed all its components. It is recommended that you keep the original packaging, packing material, receipt and confirmation of the extent of the seller's liability or warranty certificate at least for the duration of the legal right to file a defect claim or the quality warranty. When transporting the appliance, we recommend repackaging it in the original box provided by the manufacturer.
- Components that are equipped with a transmission system (chopper container lid, adapter for connecting whisks or milk frothing attachment) should be wiped with a slightly damp soft cloth. Wipe with a dry cloth.
- Thoroughly wash the accessories and parts that come into contact with food (see the list below) with warm water using a neutral kitchen detergent and soft sponge or soft brush. Then rinse everything with clean water and allow to dry freely, or wipe dry with a soft cloth.

Accessories and parts suitable for hand washing:

- Removable hand blender attachment
- Blade unit of the chopper
- 500 ml chopper container
- Beaters
- Milk frothing attachment
- 700 ml mixing and whisking container

DESCRIPTION OF THE APPLIANCE

A1 Display	A9 Chopper container lid with hole for connecting the motor unit
A2 Speed dial	A10 Blade unit of the chopper
A3 Switch to turn on/off	A11 500 ml chopper container
A4 TURBO button	A12 Anti-slip mat of the chopper
A5 Motor unit	A13 Adapter for connecting whisks or milk frothing attachment
A6 Button to release the motor unit	A14 Beaters
A7 Removable hand blender attachment	A15 Milk frothing attachment
A8 Blade unit of the hand blender attachment	A16 700 ml mixing and whisking container

INTENDED USE

Hand Blender

- It is suitable for mixing soft ingredients and liquids. It is mainly used for the preparation of baby food, various types of cocktails, sauces, spreads, etc.

Chopper

- It is suitable for chopping food such as meat, semi-hard and hard cheese, raw fruit and vegetables, nuts, herbs, etc. Do not try to process too hard food such as ice cubes, coffee beans, nutmeg, cocoa beans, etc.

Hand Mixer

- It is suitable for preparing light batters or for whipping whipped cream, egg whites and creams. Do not use for whipping thick doughs.

Milk Frothing Attachment

- It is suitable for whipping hot or cold milk and milk substitutes for further use, e.g. for making cappuccino or hot chocolate. Do not use it to whip creams, etc.

BEFORE FIRST USE

- Remove the motor unit and all accessories from the packaging material. Remove any promotional labels or tags. Make sure that no parts are damaged.
- Before storing or disposing of the packaging material, check that you have removed all parts and accessories from the packaging compartments and packaging material.
- Wipe the motor unit with a slightly damp soft cloth. Wipe with a dry cloth.



Caution:

No part of this appliance is designed to be washed in a dishwasher.



Warning:

When handling the removable attachment of the hand blender or the blade unit of the chopper, take extra care to avoid injury.



Warning:

Do not rinse the motor unit, power cord, or plug under water or immerse them in water.



Note:

You may notice a slight odour on first use. This is a normal occurrence which disappears with use.

ASSEMBLY



Warning:

Before starting to assemble the appliance, make sure that it is turned off and disconnected from the power socket. Always wait until the rotating accessories have come to a complete stop. Parts that attach to the motor unit must be dry and clean!

Hand Blender (Fig. B)

1. Attach the hand blender attachment from below to the motor unit.
2. Press gently until the hand blender attachment connects to the motor unit. A click indicates that both parts are connected.



Warning:

When handling the removable attachment of the hand blender, take extra care to avoid injury.

Chopper (Fig. C.)

1. Fit the blade unit onto the central pin on the bottom of the container.
2. Fit the lid of the chopper container so that the shaft of the blade unit fits into the central part in the lid and so that the safety locks on the sides of the lid engage with the safety system of the container. Turn the lid clockwise until it stops. This will secure it in place.

- Place the motor unit into the opening in the lid and press it down gently until you hear a click. The chopper is now assembled.



Warning:

When handling the chopper blade unit, exercise extreme caution to avoid injury.

Hand Mixer (Fig. D)

- Insert the beaters into the openings in the adaptor until they click into place. Before use, always ensure that the beaters are properly secured.
- Attach the whisk adapter to the motor unit from below. Attachment is signalled by a click.

Milk Frothing Attachment (Fig. E)

- Insert the end of the milk frothing attachment into the hole in the adapter.
- Attach the adapter with the attachment to the motor unit from below. Attachment is signalled by a click.

OPERATING THE APPLIANCE

- Select the type of accessories you want to use and assemble the appliance according to the instructions above.
- Connect the power cord plug to a power socket. Use the speed dial to set the desired speed. Turn the dial clockwise to increase speed, turn the dial anticlockwise to decrease speed.
- Press the switch as soon as the desired speed is set. Do not adjust the speed while the appliance is running.
- As long as the switch is pressed, the appliance will operate. When the switch is released, the appliance switches off.
- If you need to process ingredients quickly, press the TURBO button and the appliance will start at maximum power. When the button is released, the appliance switches off.
- Disconnect the power cord from the power socket when you have finished using it. Make sure that the rotating parts have stopped rotating and disassemble the appliance into its individual parts. Then clean all used parts according to the instructions in the chapter Cleaning and Maintenance.

Maximum recommended duration of use

Accessories	Operating time	Resting time
Hand Blender	1 minute	3–5 minutes
Chopper	1 minute (soft ingredients) 10 seconds (hard ingredients)	
Hand Mixer	2 minutes	
Milk Frothing Attachment	2 minutes	



Note:

If you are using the appliance to blend sticky or harder food, stop operation after 10 to 20 seconds.

USE OF INDIVIDUAL ACCESSORIES

Hand Blender

- Mix the food in the supplied container or other suitable container, which is intended for contact with food.
- When using the hand blender to blend food in the pot, always remove the pot from the hob first.
- The food you put in the supplied container should not be boiling or too hot to avoid damaging the container. It is recommended to allow the food to cool down to about 50 to 60°C before using the hand blender.
- Keep the blade unit submerged while the appliance is in use to avoid splashing food. You can also prevent food splashing by not overfilling

the container in which you process it. We recommend processing food in short bursts. Move the blade unit slowly up and down and in circles.

Chopper

- Cut the food into pieces of the same size and distribute the food evenly in the chopper container.
- Place the blade unit first and then the food that you wish to process.
- Do not fill the chopper container above the maximum mark.
- We recommend processing food in short bursts.
- Remove processed food using a wooden or plastic spoon, spatula or ladle.



Warning:

Do not use fingers to remove processed food. There is a serious risk of injury.

Hand Mixer

- Immerse the beaters in the container and then turn on the appliance.
- Whisk food in the supplied container or other suitable food contact container.
- Keep the beaters submerged while the appliance is running to avoid splashing food. You can also prevent food splashing by not overfilling the container in which you process it. Do not whip more than 6 egg whites or 1000 ml of cream.

Milk Frothing Attachment

- Whisk food in the supplied container or other suitable food contact container.
- Immerse the frothing attachment in milk and turn on the appliance. Move the attachment in the milk from the surface to the bottom to aerate the milk and create milk foam.
- Do not process more than 200 ml of milk. Turn off the appliance before removing the attachment from the milk.

QUICK GUIDE TO PROCESSING INGREDIENTS

Hand Blender

Ingredients	Quantity	Speed setting	Processing time
Baby food	300 g	Medium to maximum	45 s
Spreads	200 g	Medium to maximum	30 s
Fruit and vegetables (cooked)	200 g	Medium to maximum	45 s
Sauces	500 ml	Medium to maximum	45 s
Shakes/Cocktails	500 ml	Medium to maximum	30 s

Chopper

Ingredients	Quantity	Speed setting	Processing time
Meat	150 g	Medium to maximum	30 s
Fruit and vegetables (raw)	100 g	Medium to maximum	15 s
Hard and semi-hard cheeses	100 g	Maximum	15 s
Hard pastry for breadcrumbs	50 g	Medium to maximum	20 s
Shelled nuts	50 g	Maximum	15 s
Herbs	25 g	Medium	15 s



**Note:**

First cut larger pieces of food into 2 cm cubes and only then process them with a chopper. Vegetables such as onions can be cut into quarters.

Hand Mixer

Ingredients	Quantity	Speed setting	Processing time
Egg whites	4 pcs	Maximum	60 s
Whisking cream	200 ml	Maximum	60 s
Lightweight doughs	500 g	Medium to maximum	60 s

**Note:**

Always whisk the cream and egg whites in a narrow, high container. When whipping egg whites, the beaters and container must always be completely clean and dry, otherwise the whites may not be whipped to a firm consistency.

Milk Frothing Attachment

Ingredients	Quantity	Speed setting	Processing time
Milk	200 ml	Medium to maximum	30 s

**Note:**

The above food processing times are indicative only. The actual processing time depends on the size of the food, its quantity and the desired final consistency. If the desired consistency is not achieved during the maximum period of operation of the appliance, after it has cooled down, you can continue processing the food again.

DISASSEMBLY**Warning:**

Before you start disassembling the appliance, make sure that it is turned off and disconnected from the power socket. Always wait until the rotating accessories have come to a complete stop.

Hand Blender

1. With one hand, press and hold the button to release the motor unit (A6).
2. With the other hand, grasp the hand blender attachment and remove it by pulling it away from the motor unit.

**Warning:**

When handling the removable attachment of the hand blender, take extra care to avoid injury.

Chopper

1. With one hand, press and hold the button to release the motor unit (A6). Pull the motor unit upwards out of the opening in the lid.
2. Turn the lid anticlockwise to loosen it and remove it from the chopper container.
3. Remove the processed food and carefully lift the blade unit out of the chopper container.

**Warning:**

When handling the chopper blade unit, exercise extreme caution to avoid injury.

Hand Mixer

1. With one hand, press and hold the button to release the motor unit (A6).
2. With the other hand, grasp the adapter and remove it by pulling it away from the motor unit.

3. Remove the beaters from the adapter.

Milk Frothing Attachment (Fig. H)

1. With one hand, press and hold the button to release the motor unit (A6).
2. With the other hand, grasp the adapter and remove it by pulling it away from the motor unit.
3. Remove the beaters from the adapter.

CLEANING AND MAINTENANCE

Before cleaning, switch off the appliance and unplug the power cord from the mains socket. Allow the appliance to cool down.

Clean the base and used accessories immediately after use. Do not allow food residues to dry out.

**Warning:**

To prevent the risk of electric shock, do not immerse the appliance, power cable, or plug into water or any other liquid.

**Caution:**

Do not use abrasive cleaning agents, solvents, etc. to clean any parts of the appliance, as these could damage the surface. None of the components of this appliance are dishwasher safe.

**Caution:**

Do not use scouring pads (metal or plastic) to clean any parts of the appliance. They can scratch the surface and damage its finish.

Motor unit, chopper lid and adapter

- Wipe the motor unit with a slightly damp soft cloth. Wipe with a dry cloth.
- Components that are equipped with a transmission system (chopper container lid, adapter for connecting whisks or milk frothing attachment) should be wiped with a slightly damp soft cloth. Wipe with a dry cloth.

Accessories

- Thoroughly wash the accessories and parts that come into contact with food (see the list below) with warm water using a neutral kitchen detergent and soft sponge or soft brush. Then rinse everything with clean water and allow to dry freely, or wipe dry with a soft cloth.

Accessories and parts suitable for hand washing:

- Removable hand blender attachment
- Blade unit of the chopper
- 500 ml chopper container
- Beaters
- Milk frothing attachment
- 700 ml mixing and whisking container
- The blade unit of the hand blender can also be cleaned by immersing it in warm water with added dishwashing detergent after use and briefly putting the appliance into operation. Then disconnect the appliance from the power socket, disassemble and rinse the blade unit with clean drinking water and dry thoroughly.

**Caution:**

No part of this appliance is designed to be washed in a dishwasher.

**Warning:**

When handling the removable attachment of the hand blender or the blade unit of the chopper, take extra care to avoid injury.

STORAGE

- Before storage, the appliance and its accessories must be completely cool, switched off and disconnected from the power supply, clean and dry.
- Store the motor unit and all accessories in a clean, dry place out of the reach of children. Do not store the appliance folded. Do not place any accessories or foreign objects on the base.

TECHNICAL SPECIFICATIONS

Rated voltage range.....	230 V~
Rated frequency.....	50 Hz
Rated power input.....	1,500 W
Chopper container capacity.....	0.5 l
Mixing container volume.....	0.7 l
Noise level.....	85 dB(A)

Values Provided according to Commission Regulation EU 2023/826

Off Mode	
Power consumption in off mode	0.5 W
Time needed for the equipment to automatically reach off mode	0 min
Standby Mode	
Power consumption in Standby mode	-
Time needed for the equipment to automatically reach standby mode	-
Networked Standby Mode (Wi-Fi)	
Power consumption in networked standby	-
Time needed for the equipment to automatically reach networked standby mode	-

INSTRUCTIONS AND INFORMATION ON DISPOSAL OF USED PACKAGING MATERIAL

Dispose of used packaging material at the designated municipal waste disposal site.

DISPOSAL OF USED ELECTRICAL AND ELECTRONIC EQUIPMENT

Used electrical and electronic products must not be disposed of in ordinary municipal waste. To enable the proper disposal, renewal and recycling of these products, deliver them to the designated collection points. Alternatively, in some European Union states or other European countries the products can be returned to the local retailer when buying an equivalent new product. By disposing of this product correctly, you help to conserve valuable natural resources and prevent any potential adverse impact on the environment and human health that could result from improper waste disposal. For more details, contact your local authority or nearest collection point. Fines may be imposed for the improper disposal of this type of waste as per national regulations.

For business entities in European Union States

If you wish to dispose of electrical and electronic equipment, please request the necessary information from your retailer or supplier.

Disposal in other countries outside the European Union

To dispose of this product elsewhere, request the necessary information on the correct disposal method from local authorities or your retailer.

Changes to text and technical parameters are reserved.

FAST ČR, a.s.
U Sanitasu 1621
CZ-251 01 Říčany
www.sencor.com
info@sencor.cz