

Serenelife



SLFTRD40BT

foldable smart
digital treadmill

user manual

visit our website



SCAN ME

serenelifehome.com

PLEASE KEEP THIS MANUAL CAREFULLY FOR FUTURE REFERENCE. FOR HOUSEHOLD USE ONLY.

Unique Features:

- 5-Window LED Display Shows Time, Speed, Distance, Calories, and Heart Rate for Real-Time Running and Training Stats
- High-Performance Shock-Absorbing Deck Reduces Joint and Knee Impact for Safer Workouts

Features:

- 5 LED Display Windows Shows Time, Speed, Distance, Calories, and Heart Rate
- Bluetooth Music Streaming for Wireless Audio Playback from Mobile Devices
- App Integration Supports Fitness Tracking & Workout Data via Kinomap and Zwift
- Powered by a 2.5 HP Motor for Smooth and Consistent Performance
- Enhanced Cushioning System
- 2-Level Manual Incline Adjustment
- Anti-Slip Running Belt
- Built-In Pulse Sensors on Hand Grips
- Adjustable Speed Settings from 0.6 to 7.5 MPH
- 12 Preset Training Programs for Customized Workouts
- Easy Motorized Operation with Quick-Start Functionality
- Compatible with Kinomap and Zwift Fitness Apps for Guided and Interactive Training
- Safety Key with Emergency Stop
- Foldable for Storage
- Suitable for Walking, Jogging, and Light Running Workouts
- Ideal for Weight Loss, Cardio Fitness, and Endurance Training

Bluetooth Connectivity:

- Hassle-Free Pairing, No Password Required
- Compatible with Most Bluetooth-Enabled Smartphones and Tablets
- Bluetooth Version: BLE SMART 4.0
- Wireless Range: Up to 16.4 ft.

What's in the Box:

- Digital Treadmill
- (2) Locking Knobs

- (2) Hexagon Socket Oval Head Bolt M8x20
- (2) M8 Washer
- (2) Allen Wrench
- (1) Safety Key
- (1) Lubricant Oil

Technical Specs:

- Construction Material: Steel Frame with ABS/PP Plastic Components
- Motorized Treadmill Motor Power: 2.5 HP
- Adjustable Speed: 0.6 – 7.5 MPH
- Target Time Range: 5 – 99 Minutes
- Preset Training Programs: 12 Levels
- Manual Incline Adjustment: (2) Levels
- Noise Level: 60 dBA
- Maximum Weight Support: Up to 265 lbs.
- *Some Assembly Required
- Power Cable Length: 5.9 ft.
- Power Supply: 120V, 60Hz
- Item Weight: 52.03 lbs.
- Running Belt / Running Surface Size (L x W): 39.37 x 15.75 Inches
- Product Dimensions (L x W x H): 50.87 x 24.21 x 44.09 Inches

CALIFORNIA PROP 65 WARNING

WARNING:

This product may expose you to chemicals, which is known to the state of California to cause cancer, birth defects and other reproductive harm. Do not ingest.

For more info go to: www.P65warnings.ca.gov

IMPORTANT

Read all instructions carefully before using this product.

Retain this owner's manual for future reference.

Note: The specifications of this product may vary from the photo and are subject to change without prior notice.

IMPORTANT SAFETY INSTRUCTIONS

Basic precautions, including the following important safety instructions, should always be followed when using this treadmill. **Read all instructions before using this treadmill.**

DANGER

To reduce the risk of electric shock, always unplug the treadmill from the electrical outlet immediately after use and before cleaning, assembling, or servicing. Failure to follow these instructions may lead to personal injury or damage to the treadmill.

WARNING

To reduce the risk of burns, fire, electric shock, or injury to persons, please observe the following:

- Never leave the treadmill unattended while plugged in. Disconnect the power by turning off the master switch and unplugging it from the wall outlet when not in use and before putting on or taking off parts.
- Use this appliance only for its intended purpose as described in this manual. Do not use attachments not recommended by the manufacturer.
- Never operate this treadmill if it has a damaged cord or plug, or if it is not working properly. If it has been dropped, damaged, or exposed to water, return the appliance to a service center for examination and repair.
- Do not attempt any maintenance or adjustments other than those described in this manual. If any problems arise, discontinue use and contact an authorized service representative.
- Never operate the appliance with air openings blocked. Keep the air openings free of lint, hair, and other obstructions.
- Do not use the treadmill outdoors.
- Do not pull the treadmill by its power cord or use the cord as a handle.
- Keep children and pets away from the equipment while in use.
- Elderly or disabled users should only use this treadmill under adult supervision.
- Do not operate the treadmill where aerosol (spray) products are being used or where oxygen is being administered.
- Keep dry—do not operate in wet or moist conditions.
- The motor cover can become hot during use. Do not place the treadmill on a blanket or flammable surface, as this may create a fire hazard. Keep the electrical cord away from heated surfaces.
- Keep the treadmill on a solid, level surface with a minimum safety clearance of 6.5 ft (2 m) around the treadmill. Ensure the area remains free of obstructions during use.
- This treadmill is for indoor household use only.
- Only one person should use the treadmill at a time.

- Wear comfortable, appropriate clothing when using the treadmill. Always wear enclosed athletic footwear. Do not use barefoot or in socks. Avoid loose or baggy clothing, as it may become caught in the treadmill.
- Always hold on to the handrails while using the treadmill.
- Always ensure the spring knob and round knob are in place when folding or moving the treadmill.
- Do not leave children under 12 years old unsupervised near or on the treadmill.
- To disconnect, turn all controls to the OFF position, then unplug from the wall outlet.
- This appliance is not intended for use by persons (including children) with reduced physical, sensory, or mental capabilities, unless supervised or instructed by someone responsible for their safety.
- Children should not play on or near the treadmill at any time.
- **CAUTION – RISK OF INJURY TO PERSONS**
- To avoid injury, use extreme caution when stepping on or off a moving treadmill belt. Read this instruction manual carefully before use.
- Maximum Weight Capacity: 265 lbs (120 kg)
- Power Supply: 100–120V, 60 Hz grounded outlet
- Emergency Stop: Pull out the Safety Tether Key for an emergency stop.

Additional Safety Tips:

- Keep hands clear of all moving parts.
- Never place hands or feet under the treadmill while in use.
- Do not use the treadmill on a carpet thicker than 0.5 in (1.3 cm).
- Before each use, check that the belt is aligned and centered, and that all visible fasteners are secure.
- Children must not perform cleaning or maintenance without supervision.
- If the supply cord is damaged, it must be replaced by the manufacturer, service agent, or qualified personnel to prevent hazards.
- Never operate the treadmill in a folded position.
- Allow the running belt to stop completely and unplug the power cord before folding.
- Always face the computer console and never run backward on the belt.

HEALTH WARNING

Before beginning any exercise program, consult your physician.

This is especially important for individuals over 35 years of age or with pre-existing health conditions.

Read all instructions before using any fitness equipment.

Do not operate this treadmill without properly fitted guards, as exposed moving parts may cause serious injury.

ACCESSORIES

S1

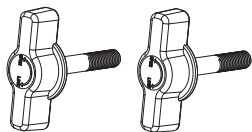

Locking Knob
x 2

S2

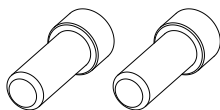

**Hexagon Socket Oval
Head Bolt M8x16**
x 2

S3

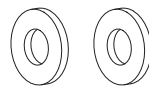

M8 Washer
x 2

TOOL KIT

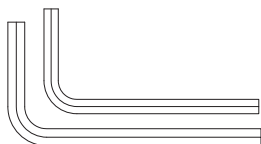

Allen Wrench x 2

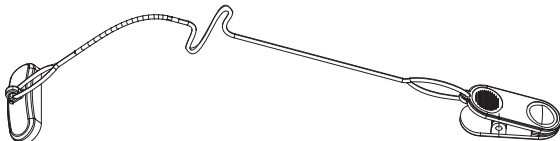

Safety Key x 1

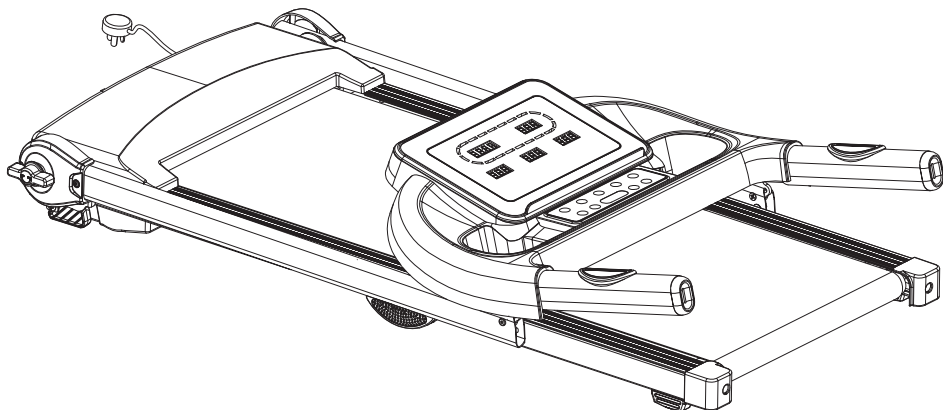

ASSEMBLY INSTRUCTIONS

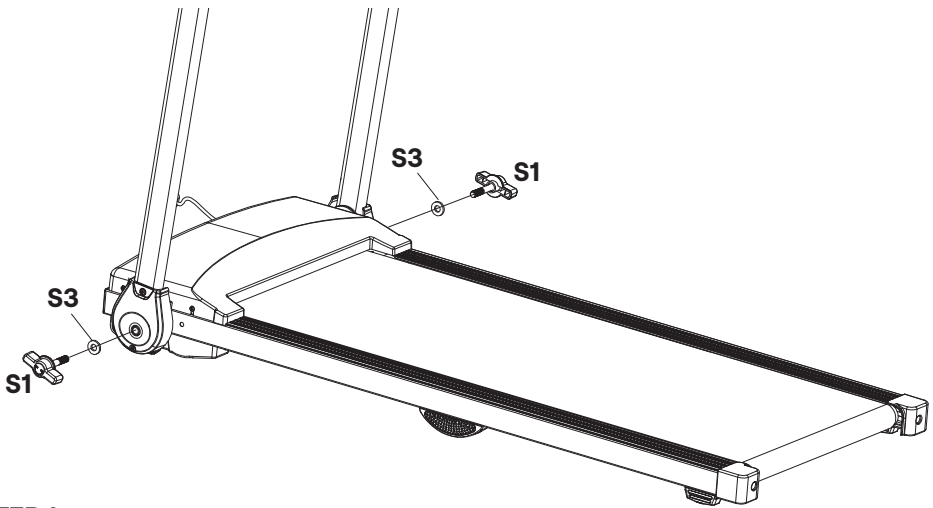

STEP 1

1. Remove the treadmill from the shipping carton and place it on a flat, level surface. Always use a second person when removing the treadmill from its carton.
2. Lift both left and right support tubes upright.
3. Use two M8 washers (S3) and two locking knobs (S1) to secure both left and right handlebar support tubes to the main frame.

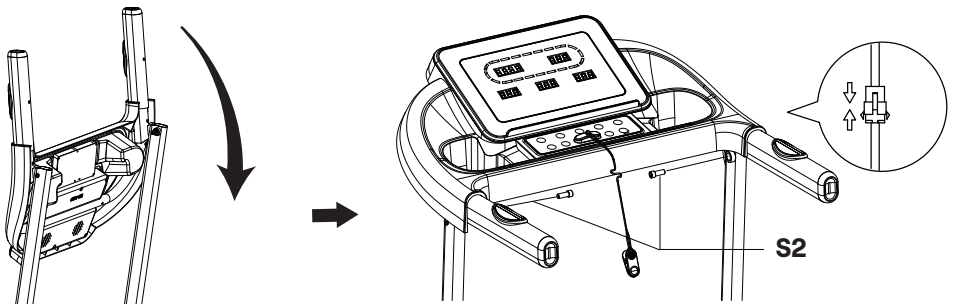

STEP 2

1. Pull the handlebar down into position.
2. Secure the handlebar to both left and right handlebar support tubes with two hexagon socket oval head bolts (M8×20), tightening them using the provided Allen wrench.

IMPORTANT:

When sliding the handlebar onto the right and left handlebar support tubes, make sure the cables are placed inside the right handlebar support tube. Avoid pinching or damaging the cables during assembly.

OPERATING THE CONTROL PANEL

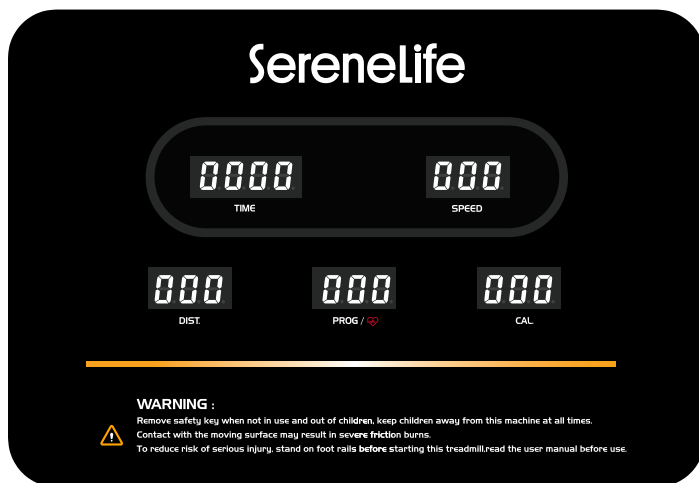

NOTE: Always stand on the side rails before starting the treadmill. Never start the treadmill while standing on the running belt.

FUNCTION BUTTONS

START: Press the START button to begin training in any mode.

STOP: Press the STOP button to end your workout or stop the treadmill at any time.

PROG (PROGRAM): Press the PROG button to select a pre-set training program (P01–P12) before starting your workout.

MODE: Press the MODE button to select different goal functions — time, distance, or calories — in manual mode before training.

INSTANT SPEED (3 / 4 / 5): Use these buttons to quickly set the treadmill to preset speeds of 3 mph, 4 mph, or 5 mph.

SPEED + (SPEED UP):

- Press the SPEED + button to increase the target time, distance, or calories before training in manual mode.
- Also used to increase speed during your workout.
- Speed range: 0.6–7.5 mph.

SPEED – (SPEED DOWN):

- Press the SPEED – button to decrease the target time, distance, or calories before training in manual mode.
- Also used to decrease speed during your workout.
- Speed range: 0.6–7.5 mph.

DISPLAY FUNCTIONS

The treadmill console displays several key workout metrics.

SPEED: Shows your current speed, adjustable between 0.6 mph and 7.5 mph. Use the SPEED + or SPEED – buttons (on the console or handrail) to adjust while exercising.

TIME: Displays your total workout time in minutes and seconds. When START is pressed, the LED counts down “3–2–1” before the belt begins moving at 0.6 mph. Time counts from 0:00 to 99:59 in 1-second increments.

DISTANCE: Displays the total distance traveled during your workout. The LED countdown sequence (“3–2–1”) appears before the belt starts at 0.6 mph. Distance accumulates continuously throughout the workout.

PROGRAM (PROG): Before starting your workout, you can select from P1–P12 exercise programs. After starting, the selected program number appears on the display. Program selection is not available in automatic mode.

CALORIES: Displays the estimated calories burned during your workout. After pressing START, the LED counts down “3–2–1” before the belt starts moving at 0.6 mph. You can adjust speed with SPEED + or SPEED – as desired.

Note: The calorie count is for reference only and should not be used for medical purposes.

TRAINING IN PRE-SET PROGRAM MODE

When in PROGRAM MODE, press the PROG button to select your desired workout (P01–P12). Press SPEED + or SPEED – to adjust the intensity, then press START to confirm and begin.

PROG	1	2	3	4	5	6	7	8	9	10	11	12	13	14	15	16	17	18	19	20
P1	1.5	2.0	2.0	2.5	3.0	2.0	2.5	3.0	3.0	2.0	2.5	3.0	2.5	2.5	2.5	1.5	2.0	2.0	3.0	2.0
P2	1.5	2.5	2.5	3.0	3.5	2.5	3.5	3.5	3.5	2.5	3.0	3.5	2.5	2.5	2.5	1.5	1.5	3.0	2.5	1.5
P3	1.5	2.5	2.5	3.5	3.5	2.5	4.0	4.0	4.0	2.5	4.0	4.0	2.5	2.5	2.5	1.5	2.5	3.0	2.0	1.5
P4	2.0	3.0	3.0	3.5	4.0	4.0	3.0	4.0	4.0	5.0	5.0	3.0	5.5	3.0	3.0	3.5	3.5	2.5	2.5	2.0
P5	1.5	2.5	2.5	3.0	3.5	4.0	4.0	3.0	3.5	4.0	5.0	5.0	3.0	2.5	2.5	3.5	3.0	3.0	2.5	1.5
P6	1.5	2.5	2.0	2.5	3.0	2.5	5.0	4.0	3.0	4.0	5.0	2.0	3.5	2.5	2.5	1.5	3.0	2.5	2.0	1.5
P7	1.5	2.0	2.0	2.0	2.5	3.0	2.0	2.5	3.0	2.0	2.5	3.0	2.0	2.0	2.0	3.5	3.5	3.0	2.0	2.0
P8	1.5	2.0	2.0	3.5	4.0	4.0	2.5	3.5	4.0	2.5	2.5	2.5	3.5	4.0	2.5	2.5	2.5	1.5	2.0	1.5
P9	1.5	2.5	2.5	4.0	4.0	2.5	4.0	5.0	2.5	5.0	5.5	5.5	2.5	2.5	2.5	3.0	3.5	2.0	2.0	1.5
P10	1.5	2.5	3.0	3.5	4.0	3.0	2.5	3.5	5.0	5.0	3.5	3.5	3.0	2.5	2.5	1.5	2.5	2.5	2.0	2.0
P11	2.0	2.5	3.0	5.5	3.0	5.5	3.0	3.0	3.0	5.5	5.5	3.0	3.0	3.0	5.5	5.5	5.0	4.0	3.5	2.0
P12	1.5	3.0	5.0	6.0	4.0	4.0	6.0	6.0	4.0	4.0	6.0	6.0	3.0	3.5	5.5	5.5	3.0	3.0	2.5	2.0

APPLICATION SOFTWARE (APP)

Check whether your mobile device meets the app requirements shown in the Google Play Store or App Store.

Try Kinomap with a 7-day trial or choose the free FIT&HOME app.



Android



Kinomap



iOS

Enable Bluetooth on your device. Because apps update frequently, refer to app store instructions or contact support for help with app operation.



Android



FIT & SHOW



iOS

Turn on Bluetooth and make your device discoverable. Select “BTMP3” to pair. Once paired, you can begin using the application.

LUBRICATION

Lubricating under the running belt will ensure superior performance and extend its life expectancy. After the first 25 hours of use (or 2–3 months), apply some lubricant, and repeat every 50 hours of use (or 5–8 months).

How to Check the Running Belt for Proper Lubrication

- Lift one side of the running belt and feel the top surface of the running deck.
- If the surface is slick to the touch, no lubrication is required.
- If the surface is dry to the touch, apply lubricant.

How to Apply Lubricant

1. Lift one side of the running belt.
2. Pour some lubricant under the center of the belt on the top surface of the running deck.
3. Run the treadmill at a slow speed for 3 to 5 minutes to evenly distribute the lubricant.



Lubricant 1 PC

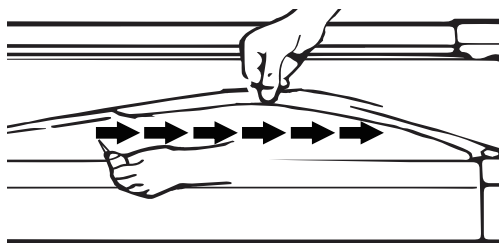

NOTE:

Do not over-lubricate the running deck. Wipe off any excess lubricant.

EMERGENCY STOP

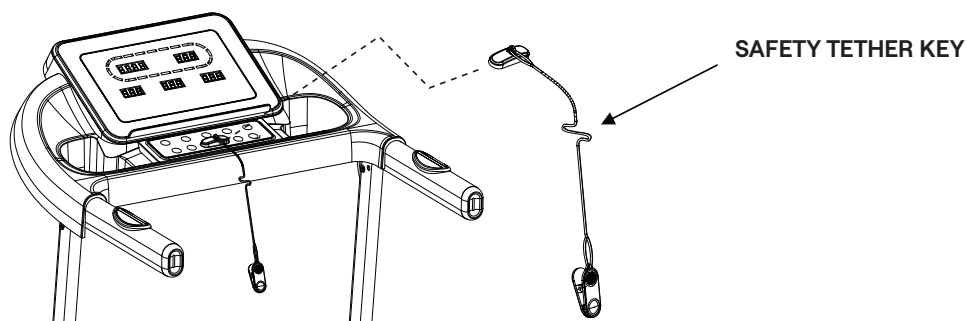

Before beginning a workout, ensure that the Safety Tether Key is properly placed onto the Computer Console and that the Safety Clip is securely attached to a piece of your clothing. If you fall, the clip will pull the **Safety Tether Key** from the Computer Console and the running belt will stop immediately to help prevent injury. Replace the Safety Tether Key onto the Computer Console. Press the START button to begin exercising again.

FOLDING THE TREADMILL

STORAGE

Store the treadmill in a clean, dry environment. Ensure the master power switch is in the OFF position and the power cord is unplugged from the wall outlet.

1. Loosen the Hexagon Socket Oval Head Bolt M8x16 (S2) that secures the operation panel.

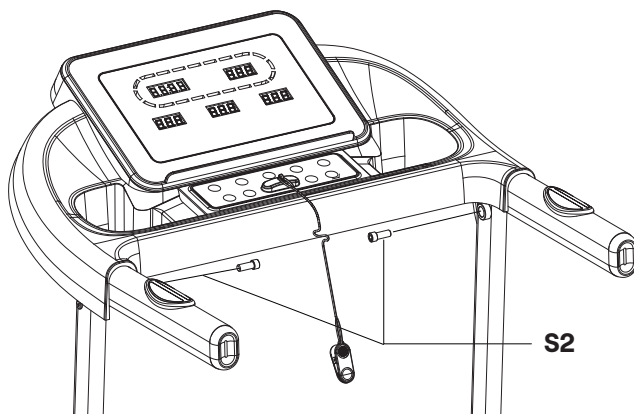

2. Flip the operation panel upward. Then loosen the Locking Knob (S1) and the M8 Washer (S3), and fold the column and operation panel downward.

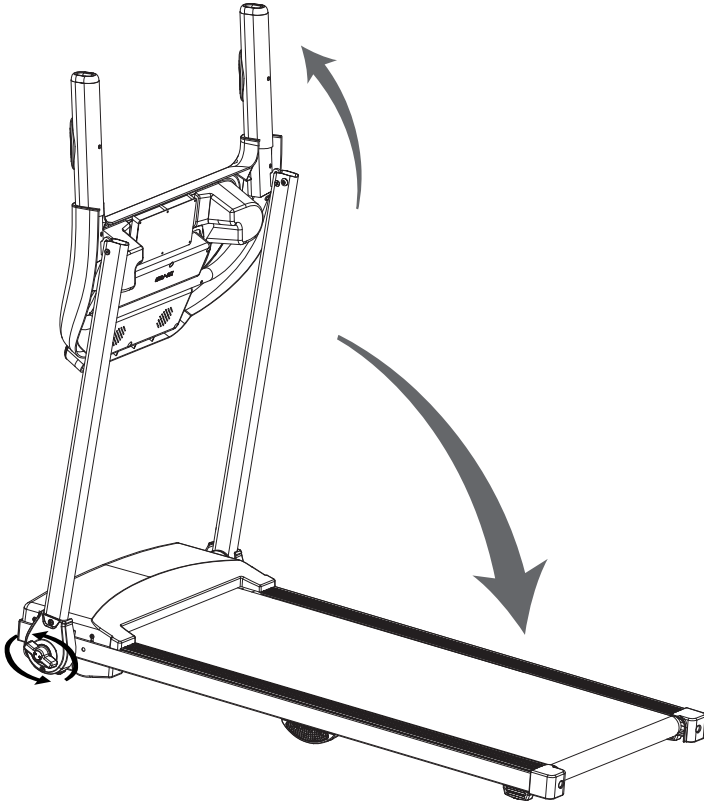

3. After completing the operation, tighten the Locking Knob (S1) to prevent shaking when moving the machine.

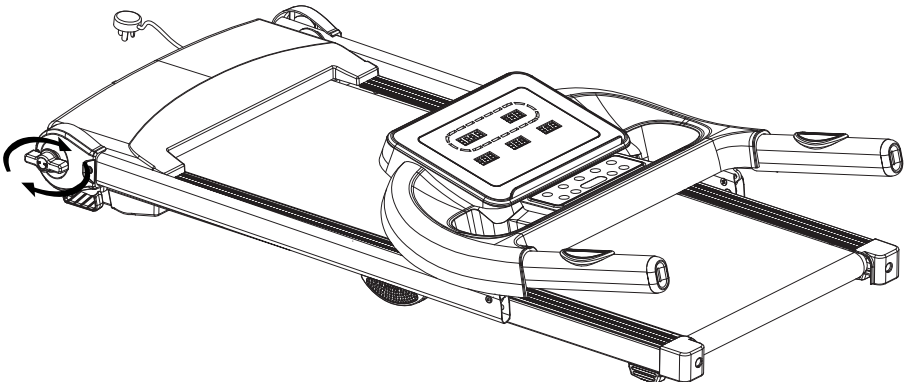

BELT ADJUSTMENT

The running belt is pre-adjusted at the factory, but over time it may stretch and require readjustment.

To adjust the belt, turn on the main power switch of the treadmill and let the belt run at a speed of 8–10 kph (about 5–6 mph). Use the provided Allen Wrench to turn the rear roller adjustment bolts and center the belt.

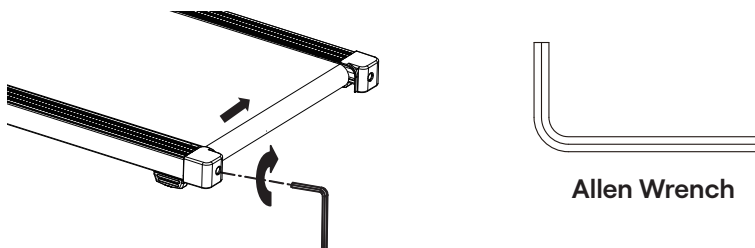

- If the running belt shifts to the left, turn the left adjustment bolt 1/4 turn clockwise.
- If the running belt shifts to the right, turn the right adjustment bolt 1/4 turn clockwise. Continue making small adjustments until the belt is properly centered.

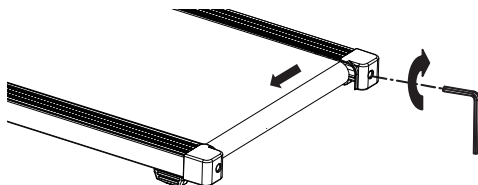

If the Running Belt Slips

1. Turn off and unplug the treadmill.
2. Using the provided Allen Wrench, turn both the left and right rear roller adjustment bolts 1/4 turn clockwise.
3. Turn the main power switch back on and run the treadmill at 8–10 kph (about 5–6 mph).
4. Step onto the running belt to check if it is still slipping.
5. Repeat this process until the belt no longer slips.

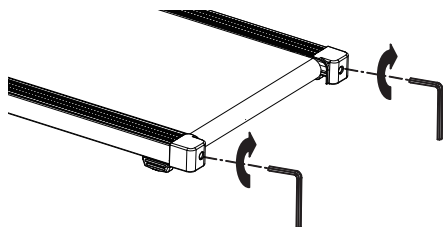

WARM UP AND COOL DOWN ROUTINE

The **WARM-UP** is an important part of any workout. The purpose of warming up is to prepare your body for exercise and to minimize injuries. Warm up for two to five minutes before aerobic exercising. It should begin every session to prepare your body for more strenuous exercise by heating up and stretching your muscles, increasing your circulation and pulse rate, and delivering more oxygen to your muscles.

COOL DOWN at the end of your workout, repeat these exercises to reduce soreness in tired muscles. The purpose of cooling down is to return the body to its resting state at the end of each exercise session. A proper cool-down slowly lowers your heart rate and allows blood to return to the heart.

HEAD ROLLS

Rotate your head to the right for one count, you should feel a stretching sensation up the left side of your neck. Then rotate your head back for one count, stretching your chin to the ceiling and letting your mouth open. Rotate your head to the left for one count, then drop your head to your chest for one count.

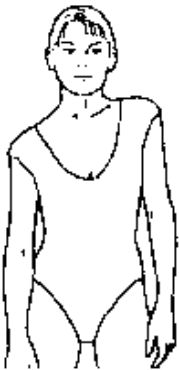

SHOULDER LIFTS

Lift your right shoulder toward your ear for one count. Then lift your left shoulder up for one count as you lower your right shoulder.

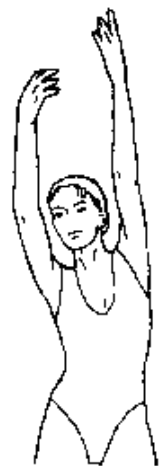

SIDE STRETCHES

Open your arms to the side and lift them until they are over your head. Reach your right arm as far toward the ceiling as you can for one count. Repeat this action with your left arm.



QUADRICEPS STRETCH

With one hand against a wall for balance, reach behind you and pull your right foot up. Bring your heel as close to your buttocks as possible. Hold for 15 counts and repeat with left foot.

INNER THIGH STRETCH

Sit with the soles of your feet together and your knees pointing outward. Pull your feet as close to your groin as possible. Gently push your knees toward the floor. Hold for 15 counts.



TOE TOUCHES

Slowly bend forward from your waist, letting your back and shoulders relax as you stretch toward your toes. Reach as far as you can and hold for 15 counts.

HAMSTRING STRETCHES

Extend your right leg. Rest the sole of your left foot against your right inner thigh. Stretch toward your toe as far as possible. Hold for 15 counts. Relax and then repeat with left leg.

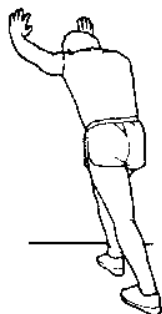
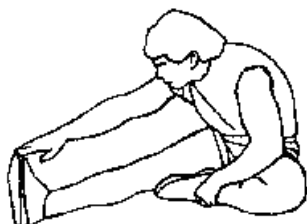

CALF/ACHILLES STRETCH

Lean against a wall with your right leg in front of the left and your arms forward. Keep your left leg straight and the right foot on the floor; then bend the right leg and lean forward by moving your hips toward the wall. Hold, then repeat on the other side for 15 counts.

CARE, MAINTENANCE & TROUBLESHOOTING GUIDE

WARNING: To prevent electrical shock, turn off and unplug the treadmill before cleaning or performing maintenance. Regularly check wear-and-tear parts such as the spring knob and running belt.

CLEANING

- After each use, wipe down the unit and remove any sweat.
- Clean with a soft cloth and mild detergent. Do not use abrasives or solvents.
- Avoid getting moisture on the display panel.
- Keep the treadmill and console out of direct sunlight.

STORAGE

- Store indoors in a clean, dry location.
- Never use or store the unit outdoors.
- Ensure the master power switch is off and the power cord is unplugged.

TROUBLESHOOTING GUIDE

Treadmill Will Not Start

- **Treadmill is not plugged in:** Plug the power cord into a wall outlet.
- **Safety Tether Key is not installed correctly:** Reinstall the Safety Tether Key.
- **House circuit breaker is tripped:** Reset the breaker or contact an electrician.
- **Treadmill circuit breaker is tripped:** Wait 5 minutes, then restart.

Belt Slips: Belt not tight enough: Adjust belt tension.

Belt Hesitates When Stepped On

- **Not enough lubrication:** Apply lubricant.
- **Belt is too tight:** Adjust belt tension.

Belt Is Not Centered

Uneven tension across rear roller: Center the belt.

Register Product

Thank you for choosing SereneLife. By registering your product, you ensure that you receive the full benefits of our exclusive warranty and personalized customer support. Complete the form to access expert support and to keep your SereneLife purchase in perfect condition.

Start Here



Model Number:
SLFTRD40BT

[SereneLifeHome.com/pages/register](https://serenellifehome.com/pages/register)



questions? comments?

We are here to help!
Phone: 1.718.535.1800
[serenelifehome.com/contact us](http://serenelifehome.com/contact-us)