

morphy richards®

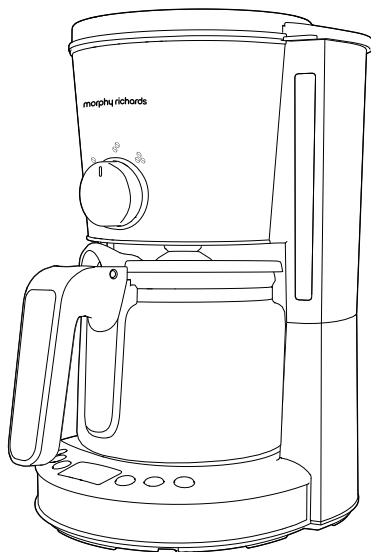

Filter Coffee Maker with Timer and Glass Carafe

Please read and keep these instructions

AUS



www.morphyrichards.com



Health and Safety

The use of any electrical appliance requires the following common sense safety rules.

Please read these instructions carefully before using the product.

- **WARNING: Misuse of the appliance could cause personal injury.**
- This appliance can be used by children aged from 8 years and above if they have been given supervision or instruction concerning the use of the appliance in a safe way and if they understand the hazards involved. Cleaning and user maintenance shall not be made by children unless they are older than 8 and supervised. Keep the appliance and its cord out of the reach of children aged less than 8 years.
- If the mains cable is damaged, it must be replaced by the manufacturer, its service agent or similarly qualified person in order to avoid a hazard.
- Appliances can be used by persons with reduced physical, sensory or mental capabilities or lack of experience and knowledge if they have been given supervision or instruction concerning use of the appliance in a safe way and understand the hazards involved.
- The appliance is fitted with a heating element which is subject to residual heat after use.
- Children shall not play with the appliance.
- This appliance is intended to be used in household and similar applications such as: farm houses, by clients in hotels, motels and other residential type environments, and bed and breakfast type environments. It is not suitable for use in staff kitchen areas in shops, offices and other working environments.

Location

- Always locate your appliance away from the edge of the worktop.
- Ensure that the appliance is used on a firm, flat surface.
- Do not use the appliance outdoors or near water.
- **WARNING: Do not place the appliance onto a metal tray or metal surface whilst in use.**

Mains cable

- Do not let the mains cable hang over the edge of the worktop where a child could reach it.
- Do not let the mains cable run across an open space e.g. between a low socket and a table.
- Do not let the mains cable run across a cooker or other hot area which might damage the cable.
- The mains cable should reach from the socket to the base unit without straining the connections.

Personal safety

- **WARNING: To protect against fire, electric shock and personal injury do not immerse cord, plug and appliance in water or any other liquid.**
- Unplug from the outlet before cleaning.
- Allow to cool before putting on or taking off parts and before cleaning.
- Do not move the Coffee Maker while switched on.

Other safety considerations

- The use of attachments or tools not recommended or sold by Morphy Richards, may cause fire, electric shock or injury.
- Do not use the appliance for any use other than its intended purpose.
- Do not place the appliance on or near a hot gas or electric burner or in a heated oven.
- **WARNING: The appliance must not be immersed for cleaning.**
- **CAUTION:** To prevent damage to the appliance, do not use alkaline cleaning agents when cleaning. Use a soft cloth and detergent.

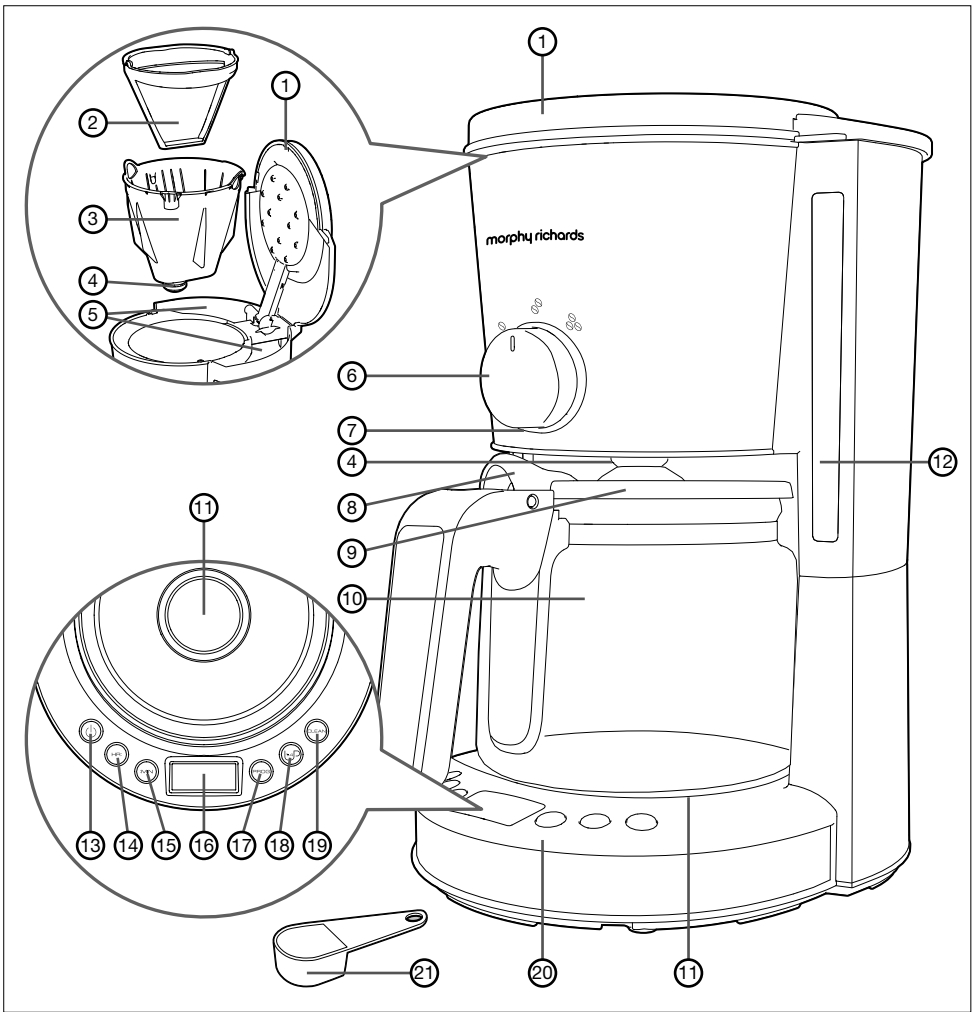

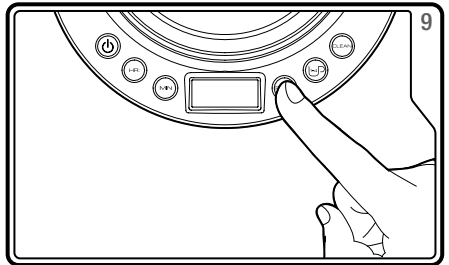
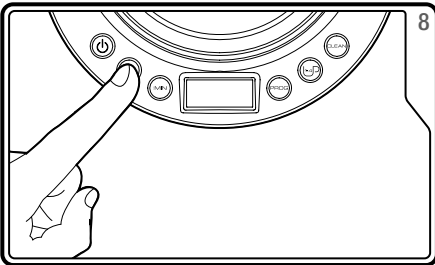
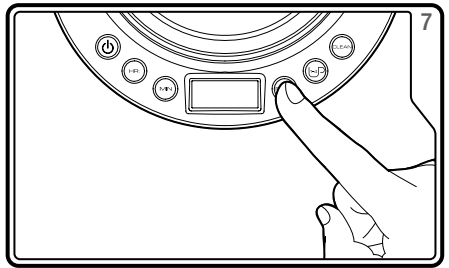
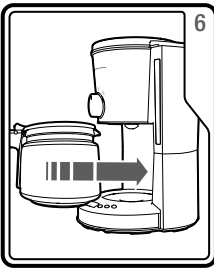
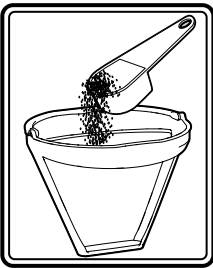
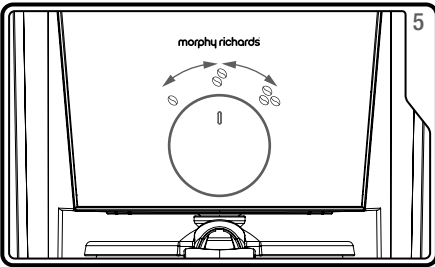
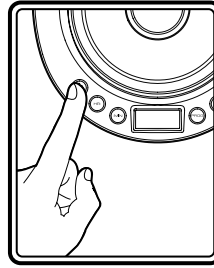
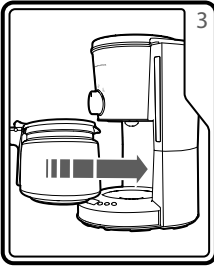
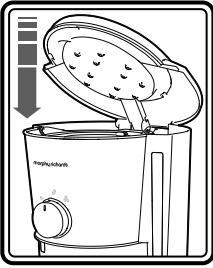
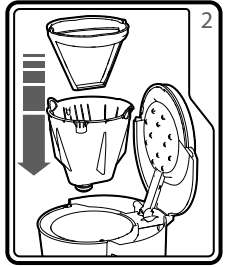
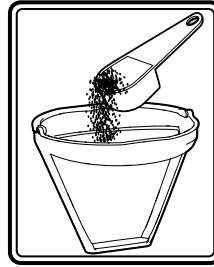
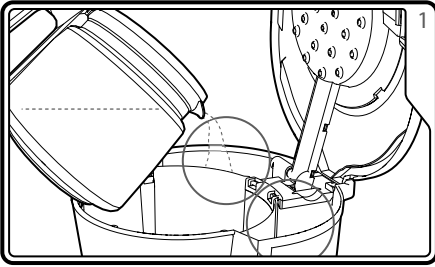

Features

- (1) Lid
- (2) Removable Permanent Filter
- (3) Removable Filter Holder
- (4) Coffee Dispenser Valve
- (5) Water Reservoir
- (6) Strength Selector Dial
- (7) Heating Light
- (8) Carafe Lid Open Lever
- (9) Carafe Lid
- (10) Glass Carafe
- (11) Warming Plate
- (12) Water Gauge
- (13) On/Off Button
- (14) Hour Button
- (15) Minute Button
- (16) Display Screen
- (17) Program Button
- (18) 1-4 Cup Button
- (19) Clean Button
- (20) Control Panel
- (21) Coffee Spoon

Quick Start Guide

Before First Use

- Take your Coffee Maker out of the box and remove the packaging.
- Wash the detachable parts of the machine in warm soapy water.
- The first time you use your Coffee Maker, operate the Coffee Maker with water only.

Setting the Clock

When the Coffee Maker is plugged in, the Display Screen (16) will illuminate and the clock will automatically start counting from 12:00. After 10 seconds, the machine will enter standby mode and the screen will dim.

- To set the time, you can use the Hour (14) and Minute (15) Buttons to adjust the clock. The display is a 24 hour clock.

Using Your Coffee Maker

- 1** Fill the Water Reservoir (5) with cold water. Do not overfill.
- 2** Use the Coffee Spoon (21) to add filter coffee into the Removable Permanent Filter (2). We recommend 7g (one spoon) of coffee per cup. Place the Filter into the Removable Filter Holder (3) in the Coffee Maker ensuring the Filter Holder locates into place.
- 3** Close the Lid (1) and replace the Glass Carafe (10) into the Coffee Maker.
- 4** Press the On/Off Button (13) to start the brewing process. The Heating Light (7) around the Strength Selector Dial (6) will illuminate red. To stop the brewing process, press the On/Off Button a second time.

At the end of the brewing cycle, the Heating Light (7) will remain illuminated but the light will turn blue, then switch off when the keep warm cycle has finished.

Using the Strength Selector

- You can adjust the brew strength by turning the Strength Selector Dial (6) to your taste.
- If you are brewing 1-4 cups, the machine can automatically set the optimum program for you. This is specially adapted for small quantities and will override the Strength Selector Dial. Follow the instructions below:
- For brewing 1-4 cups of coffee, press the 1-4 Cup Button (18). The 1-4 cup symbol will appear on the Display Screen (16). Press the On/Off Button (13) to confirm. The brew cycle will commence and the Heating Light (7) will illuminate red.

To Pre-set a Brewing Time

- 6** Follow 'Using your Coffee Maker' steps 1-3 on page 4.
- 7** Press the Program Button (17) so that 'PROGRAM' flashes on the Display Screen (16) and the time shows as 12:00.
- 8** Select the brewing start time using the Hour (14) and Minute (15) Buttons.
- 9** When you have selected the desired time press the Program Button (17), the Display screen will return to showing the current time and 'PROGRAM' will remain on the screen.

NOTE: If the Program Button has not been pressed to confirm, the Display Screen will return to the current time and the pre-set brewing time will not be activated.

To cancel, press the Program Button again. 'PROGRAM' will disappear from the Display Screen.

Refilling Your Coffee Maker

- Switch off your Coffee Maker and allow 3 minutes to cool before refilling with cold water.

Keep Warm

After the brewing cycle has finished, your Coffee Maker will activate the keep warm function which will keep your coffee warm for approximately 30 minutes.

The Heating Light (7) will remain illuminated but the light will turn from red to blue, then switch off when the keep warm cycle has finished.

To switch the keep warm mode off press the On/Off Button.

Cleaning Your Coffee Maker

- Unplug the Coffee Maker and allow to cool.
- Do not immerse the Coffee Maker in liquid.
- Rinse the Water Reservoir (5) occasionally with cold water. Do not use a cloth as any residue or lint may be left behind to clog the Coffee Maker.
- Remove the Permanent Filter (2), discard any used coffee and wash. Extended soaking helps to remove coffee stains from the mesh.
- Wash the Glass Carafe (10), Carafe Lid (9), and Removable Filter Holder (3) in warm soapy water. Rinse and dry all parts thoroughly. Refit the Permanent Filter (2) and Filter Holder.
- Wipe all external surfaces with a damp cloth and dry thoroughly.
- Care must be taken to ensure that the non-drip Coffee Dispenser Valve (4) situated on the bottom of the Removable Filter Holder is not damaged during cleaning.
- Never use harsh or abrasive cleaners.
- NO parts are suitable for cleaning in a dishwasher.

Auto clean

- For a deeper clean follow these instructions.
- 1 Combine 6 cups of white vinegar and 4 cups of cold water in the reservoir.
 - 2 Press the Clean Button (19). The screen will indicate CLEAN. Press the On/Off Button (13) to confirm. Your coffee maker will beep and begin the cycle.
 - 3 Leave the machine for 45-60 minutes until the cycle is complete.
 - 4 Discard the dirty liquid in the Glass Carafe (10) and run your coffee maker with cold water for a further 2 or 3 times before using again.

Descaling

- If you live in a hard water area, we recommend that your Coffee Maker is descaled at regular intervals, e.g. every 1-2 months. In areas of moderately hard water, you should descale every 3 months.
- If the water filters through more slowly than usual, or if water still remains in the reservoir at the end of a cycle, it is a sign that descaling is necessary.
- We recommend you use a proprietary liquid descaler which is especially made for coffee makers and plastic kettles. Follow the instructions on the bottle or sachet, and then operate the Coffee Maker with just water 3 times before making coffee.
- Do not use a kettle descaler unless the packet specifically states it is suitable for Coffee Makers.

Note: The Removable Permanent Filter should not be used during descaling.

Contact Us

Helpline

If you are having a problem with your appliance, please call our Helpline, as we are more likely to be able to help than the store you purchased the item from.

Please have the product name, model number and serial number to hand when you call to help us deal with your enquiry quicker.

Talk To Us

If you have any questions or comments, or want some great tips or recipe ideas to help you get the most out of your products, join us online:

Blog:	www.homeofthehouseproud.com
Facebook:	www.facebook.com/morphyrichardsuk
Twitter:	www.twitter.com/loveyourmorphy
Website:	www.morphyrichards.com

AUS

THIS SECTION IS ONLY APPLICABLE FOR CUSTOMERS IN UK AND IRELAND

REGISTERING YOUR TWO YEAR GUARANTEE

Your standard one year guarantee is extended for an additional 12 months when you register the product within 28 days of purchase with Morphy Richards. If you do not register the product with Morphy Richards within 28 days, your product is guaranteed for 1 year. To validate your 2 year guarantee register with us online at www.morphyrichards.co.uk

N.B. Each qualifying product needs to be registered with Morphy Richards individually. Please refer to the one year guarantee for more information.

YOUR ONE YEAR GUARANTEE

It is important to retain the retailer's receipt as proof of purchase. Staple your receipt to this back cover for future reference. Please quote the following information if the product develops a fault. These numbers can be found on the base of the product.

Model no.
Serial no.

All Morphy Richards products are individually tested before leaving the factory. In the unlikely event of any appliance proving to be faulty within 28 days of purchase, it should be returned to the place of purchase for it to be replaced. If the fault develops after 28 days and within 12 months of original purchase, you should contact the Helpline number quoting Model number and Serial number on the product, or write to Morphy Richards at the address shown. You may be asked to return a copy of proof of purchase. Subject to the exclusions set out below (see Exclusions), the faulty appliance will then be repaired or replaced and dispatched usually within 7 working days of receipt. If, for any reason, this item is replaced during the 1 year guarantee period, the guarantee on the new item will be calculated from original purchase date. Therefore it is vital to retain your original till receipt or invoice to indicate the date of initial purchase. To qualify for the 1 year guarantee, the appliance must have been used according to the instructions supplied. For example, crumb trays should have been emptied regularly.

EXCLUSIONS

Morphy Richards shall not be liable to replace or repair the goods under the terms of the guarantee where:

- 1 The fault has been caused or is attributable to accidental use, misuse, negligent use or used contrary to the manufacturer's recommendations or where the fault has been caused by power surges or damage caused in transit.
- 2 The appliance has been used on a voltage supply other than that stamped on the products.
- 3 Repairs have been attempted by persons other than our service staff (or authorised dealer).
- 4 The appliance has been used for hire purposes or non domestic use.
- 5 The appliance is second hand.
- 6 Morphy Richards are not liable to carry out any type of servicing work, under the guarantee.
- 7 Plastic filters for all Morphy Richards kettles and coffee makers are not covered by the guarantee.
- 8 Batteries and damage from leakage are not covered by the guarantee.
- 9 The filters have not be cleaned and replaced as instructed.

This guarantee does not confer any rights other than those expressly set out above and does not cover any claims for consequential loss or damage. This guarantee is offered as an additional benefit and does not affect your statutory rights as a consumer.

YOUR INTERNATIONAL TWO YEAR GUARANTEE

This appliance is covered by two-year repair or replacement warranty.

It is important to retain the retailers receipt as proof of purchase. Staple your receipt to this back cover for future reference.

Please quote the following information if the product develops a fault. These numbers can be found on the base of the product.

Model no.
Serial no.

All Morphy Richards products are individually tested before leaving the factory. In the unlikely event of any appliance proving to be faulty within 28 days of purchase it should be returned to the place of purchase for it to be replaced.

If the fault develops after 28 days and within 24 months of original purchase, you should contact your local distributor quoting Model number and Serial number on the product, or write to your local distributor at the addresses shown.

You will be asked to return the product (in secure, adequate packaging) to the address below along with a copy of proof of purchase.

Subject to the exclusions set out below (1-9) the faulty appliance will then be repaired or replaced and dispatched usually within 7 working days of receipt.

If for any reason this item is replaced during the 2-year

guarantee period, the guarantee on the new item will be calculated from original purchase date. Therefore it is vital to retain your original till receipt or invoice to indicate the date of initial purchase.

To qualify for the 2-year guarantee the appliance must have been used according to the manufacturers instructions. For example, appliances must have been descaled and filters must have been kept clean as instructed.

The local distributor shall not be liable to replace or repair the goods under the terms of the guarantee where:

- 1 The fault has been caused or is attributable to accidental use, misuse, negligent use or used contrary to the manufacturers recommendations or where the fault has been caused by power surges or damage caused in transit.
- 2 The appliance has been used on a voltage supply other than that stamped on the products.
- 3 Repairs have been attempted by persons other than our service staff (or authorised dealer).
- 4 Where the appliance has been used for hire purposes or non domestic use.
- 5 The appliance is second hand.
- 6 The local distributor are not liable to carry out any type of servicing work, under the guarantee.
- 7 The guarantee excludes consumables such as bags, filters and glass carafes.
- 8 Batteries and damage from leakage are not covered by the guarantee.
- 9 The filters have not been cleaned and replaced as instructed.

This guarantee does not confer any rights other than those expressly set out above and does not cover any claims for consequential loss or damage. This guarantee is offered as an additional benefit and does not affect your statutory rights as a consumer.

AUSTRALIAN WARRANTY

This appliance is guaranteed for 2 years against faulty material, components and workmanship.

This warranty is in addition and does not affect your statutory rights.

Proof of purchase must be produced for any warranty benefit.

In the unlikely event of any appliance proving to be faulty, securely pack and return the item to the place of purchase accompanied by the original receipt or invoice.

Our goods come with guarantees that cannot be excluded under the Australian Consumer Law. You are entitled to a replacement or refund for a major failure and for compensation for any other reasonably foreseeable loss or damage. You are also entitled to have the goods repaired or replaced if the goods fail to be of acceptable quality and the failure does not amount to a major failure.

NOT COVERED BY THIS WARRANTY

(Australian only)

- If the appliance has not been used in accordance with the manufacturers' recommendations or Instructions.
- If the fault is deemed to be caused by abuse, misuse, neglect, modifications or in proper use and or care
Eg: Kettles: Excessive build up of scale.
Toasters: Excessive build up of crumbs or foreign matter etc.
- Connection to incorrect voltage to that stamped on the product.
- Unauthorised repairs.
- Appliance used other than for domestic purposes.
- Excluding bags, filters, glass, carafes, and cutting blades.
- Freight and insurance costs.

If for any reason this item is replaced during the 2 year guarantee period, the guarantee on the new item will be calculated from original purchase date. Therefore it is vital to retain your original receipt or invoice to indicate the date of original purchase.

Morphy Richards's policy is to continually improve quality design and product quality. The company therefore reserves the right to change any specifications or to carry out modifications as deemed worthy at any time.

The Australian supplier reserves the right to repair, modify, exchange or replace the faulty appliance with the same or similar model or product of equivalent value.

AUS

-
- GB** Morphy Richards products are intended for household use only.
Morphy Richards has a policy of continuous improvement in product quality and design.
The Company, therefore, reserves the right to change the specification of its models at any time.

The After Sales Division,

Morphy Richards Ltd, Mexborough, South Yorkshire, England, S64 8AJ
Helpline (office hours) UK 0845 871 0960
Republic of Ireland 1800 409119

- AUS** **Glen Dimplex Australia**
1340 Ferntree Gully Road, Scoresby, Victoria 3179
T : 1300 556 816
E : sales@glendimplex.com.au

- NZ** **Glen Dimplex New Zealand**
38 Harris Road, East Tamaki, Auckland, New Zealand
T : 09 2748265
E : sales@glendimplex.co.nz

morphyrichards®

CM162520MAUS Rev 1 08/18

www.morphyrichards.com