

# REGO Inverter Charger

12V | 3000W

VERSION A0

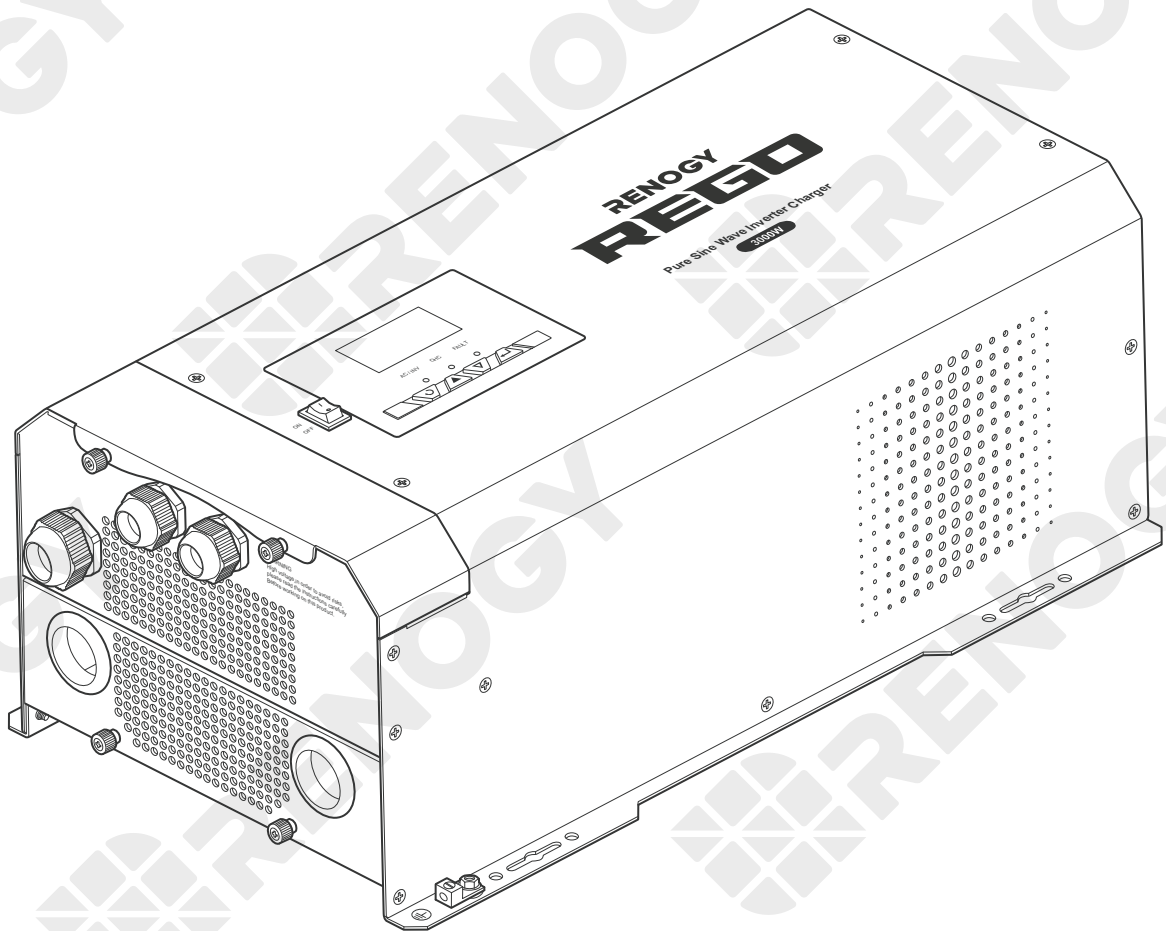

USER MANUAL

## Applicability

The user manual applies to the following product:

- REGO 12V 3000W Inverter Charger (RIV1230RCL-1SS-G1)

## Disclaimer

- Renogy makes no warranty as to the accuracy, sufficiency, or suitability of information in the user manual because continuous product improvements are going to be made.
- Renogy assumes no responsibility or liability for losses or damages, whether direct, indirect, consequential, or incidental, which might arise out of the use of information in the user manual.
- Renogy is not responsible or liable for the failures, damages, or injuries resulting from repair attempted by unqualified personnel or improper installation and operation.
- The illustrations in the user manual are for demonstration purposes only. Details may appear slightly different depending on product revision and market region.
- Renogy reserves the right to change the information in the user manual without notice.

## Copyright

REGO 12V 3000W Inverter Charger User Manual © 2022 Renogy. All rights reserved. All information in the user manual is subject to copyright and other intellectual property rights of Renogy and its licensors. The user manual may not be modified, reproduced, or copied, in whole or in part, without the prior written permissions of Renogy and its licensors.

## Trademarks

The following are trademarks or registered trademarks of Renogy in the United States and other countries and regions:

RENOGY	<b>RENOGY</b>
--------	---------------

All other trademarks in the user manual are the property of their respective owners and their use herein does not imply sponsorship or endorsement of their products or services. The unauthorized use of any trademark displayed in the user manual or on the product is strictly prohibited.

## Date and Revision

January 2022, Revision A0

# Table of Contents

Important Safety Information .....	06
Symbols Used .....	06
General Safety Information .....	06
Introduction.....	08
General Information .....	08
Key Features .....	08
Package Contents .....	10
Optional Accessories .....	11
Product Overview .....	12
External View .....	12
Internal View.....	13
Wiring Diagram.....	14
Recommended Cable Sizing.....	15
Components & Tools .....	16
Inspection .....	19
Inspecting Inverter Charger.....	19
Environment.....	19
Placement .....	20
Checking Battery.....	21
Preparation .....	23
Mounting .....	23
Removing the Plate.....	23
Cautions .....	24
Ground Cable Wiring.....	25
Remote Control Wiring .....	27

Temperature Sensor Wiring .....	28
Battery Wiring .....	30
Device-side Wiring .....	30
Battery-side Wiring .....	32
AC Output Wiring .....	38
Device-side Wiring .....	38
Load Wiring .....	39
AC Input Wiring .....	41
Automatic Generator Start .....	43
Communication .....	47
Inter-Device Communication .....	47
Monitoring Device Communication .....	52
Putting Plates Back .....	57
Power on .....	58
Main Switch .....	58
Wired Remote Control .....	59
Operation .....	60
LCD .....	60
Button .....	63
Setting Battery Type .....	64
User Mode .....	67
Working .....	73
Working Logic .....	75
Power Supply Logic .....	75
Charging Logic .....	75
Heat Dissipation Logic .....	77
Power off .....	78
Main Switch .....	78

Wired Remote Control.....	78
Overcurrent Protection .....	80
LED Indicators .....	81
Indicator of the Inverter Charger .....	81
Indicator of the Wired Remote Control.....	81
Program Codes .....	82
Warning/Fault Codes.....	91
Technical Specifications .....	93
Dimensions.....	95
Maintenance.....	96
Inspection.....	96
Cleaning .....	96
Storage.....	96
Emergency Responses .....	97
Fire .....	97
Flooding .....	97
Smell .....	97
Noise .....	97
Technical Support.....	98

# Important Safety Information





Symbols Used

General Safety Information

The user manual provides important installation, operation, and maintenance instructions for REGO 12V 3000W Inverter Charger (hereinafter referred to as inverter charger). Read the user manual carefully before installation and operation and save it for future reference. Failure to observe the instructions or precautions in the user manual can result in electrical shock, serious injury, or death, or can damage the inverter charger, potentially rendering it inoperable. The installation and service of the inverter charger might require knowledge of high voltage electricity and is recommended to be carried out by qualified personnel.

## Symbols Used

The following symbols are used throughout the user manual to highlight important information:

	<b>WARNING</b>	Indicates a potentially dangerous condition which could result in injury or death.
	<b>CAUTION</b>	Indicates a critical procedure for safe and proper installation and operation.
	<b>NOTE</b>	Indicates an important step or tip for optimal performance.
	<b>INFO</b>	Indicates that more information is available in other documents relating to the subject.

## General Safety Information

### **WARNING**

- The voltage of the inverter charger exceeds the human body safety voltage. Read all instructions and precautions in the manual before installation.
- Inspect the inverter charger for any visible damage including cracks, dents, deformation, and other visible abnormalities before installation.
- Do not puncture, drop, crush, penetrate, shake, strike, or step on the inverter charger.
- Do not open, dismantle, repair, tamper with, or modify the components of the inverter charger.
- Install the inverter charger on a vertical surface indoors protected from direct sunlight, high temperature, and water. Make sure there is good ventilation.
- Keep the inverter charger away from heating equipment.
- Do not insert foreign objects into the inverter charger.
- Do not install the inverter charger near flammable fumes or gases.
- Keep the inverter charger out of the reach of children.
- Wear proper protective equipment and use insulated tools during installation and operation. Do not wear metal jewelry, such as necklaces and watches.
- Do not touch the connector contacts while the inverter charger is in operation.

# Important Safety Information

Symbols Used

General Safety Information

- Disconnect all connectors from the inverter charger before maintenance or cleaning.
- Risk of electric shock! Be careful when touching bare terminals of the inverter charger as they may retain high lethal voltages even after power is removed.
- Do not dispose of the inverter charger as household waste. Comply with local, state, and federal laws and regulations and use recycling channels as required.
- In the event of fire, use fire extinguishers suitable for electrical equipment.
- If the inverter charger is installed improperly on a boat, it may cause damage to the corrosive agents of the boat. Please have the inverter charger installed by a qualified electrician.



## CAUTION

- Do not expose the inverter charger to flammable or harsh chemicals or vapors.
- Ensure that there is no water source including downspouts, sprinklers, or faucets above or near the inverter charger.
- Ensure that the battery bank is properly connected before installation.
- Check the installation environment of the inverter charger regularly and keep it clean to prevent the ventilation holes from being blocked by debris or dust.

# Introduction

General Information

Key Features

## General Information

REGO 12V 3000W Inverter Charger is your off-grid smart living center that revolutionizes comfort when you live in your off-grid home or RV. The inverter charger can invert DC to AC and directly supply power to the load, and charge the battery when it is connected to the utility power.

In addition, it supports different types of batteries such as AGM, Gel, Sealed Lead Acid (SLA), and Li. The inverter charger can switch power supply from the utility power to batteries within 10 milliseconds, ensuring a smooth mode switch without powering off the load. The lever style connectors make AC IN/OUT connections simply and easy. They simplify installation and shorten the installation time.

The inverter charger can be connected to Renogy devices and smart accessories via Bluetooth or RV-C. When the inverter charger works in association with the DC Home app, you will have the same system monitoring wherever you go on your smartphone. With advanced pure sine wave technology, the inverter charger can protect and extend the life of your electronic equipment and loads.

## Key Features

- **Robust and sleek design**

The housing of the inverter charger is made of steel plates to ensure its firmness and a more fashionable appearance.

- **Intuitive LCD and LED**

You can view and check the status displayed on the LCD and LEDs, and modify parameters of the inverter charger according to the actual use.

- **High quality waveform with little harmonic distortion**

Advanced Pure Sine Wave technology provides high-quality AC power equivalent to the grid power. The voltage increases and decreases in a smooth way with little harmonic distortion.

- **Multi-stage Battery charging**

Up to three stage battery charging including bulk, boost, and float as well as equalization for select battery types

- **Configurable charging current**

The maximum charging current of the inverter charger is 75A, adjustable at 5A each time. The charging current can be adjusted to satisfy your daily use.

- **Nine preset battery voltages and custom options**

The inverter charger is compatible with nine types of batteries to meet your needs in daily use. You can also customize the battery parameters of the inverter charger.

- **Automatic generator start**

The inverter charger is equipped with a set of NO and NC dry contacts, which are used to connect the generator with automatic start and stop function and automatically charge the battery, facilitating your daily use.

# Introduction

General Information

Key Features



- **Peak conversion efficiency >90%**

The peak conversion efficiency is more than 90% during operation, which reduces the energy loss.

- **Multiple electronic protections**

The inverter charger is equipped with undervoltage protection, overvoltage protection, overload protection, overtemperature protection, and short circuit protection.

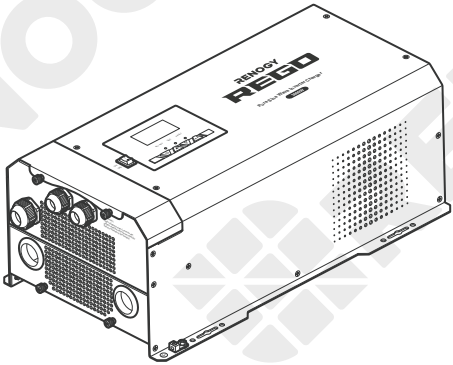
# Package Contents

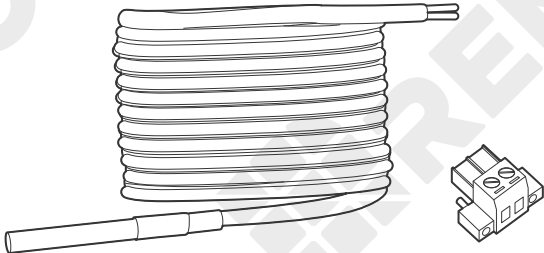
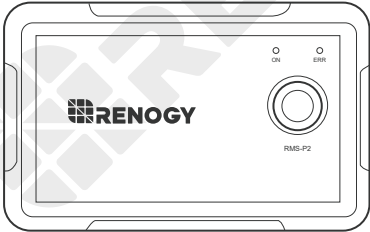
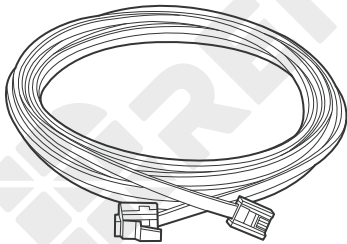
<p>REGO 12V 3000W Inverter Charger × 1</p>	<p>Quick Guide × 1</p>
 A detailed line drawing of the REGO 12V 3000W Inverter Charger. It is a rectangular, boxy device with a silver and black color scheme. The front panel features several circular ports on the left side and a large, perforated grille on the right side. The top surface has the 'REGO' logo and some technical specifications.	 A line drawing of the Quick Guide booklet. The cover is black with the 'REGO' logo at the top right. Below the logo, it reads 'REGO Inverter Charger 12V   3000W'. In the center, there is a smaller image of the inverter charger. At the bottom, it says 'QUICK GUIDE'.
<p>Battery Temperature Sensor x 1</p>	<p>Wired Remote Control x 1</p>
 A line drawing of a battery temperature sensor. It consists of a long, flexible, braided cable that is coiled. At the end of the cable is a small, rectangular electronic sensor module with two pins extending from it.	 A line drawing of a wired remote control. It is a rectangular device with a black face and a silver border. The face features the 'REGO' logo on the left, a circular button in the center labeled 'RMS-P2', and two small indicator lights at the top right labeled 'ON' and 'OFF'.
<p>RJ11 Network Cable (5 m) x 1</p>	
 A line drawing of an RJ11 network cable. It is a long, thin cable that is coiled. Both ends of the cable are terminated with RJ11 connectors, which are small plastic modules with four pins.	

# Optional Accessories

## NOTE

- You can buy optional accessories from [renogy.com](https://renogy.com).

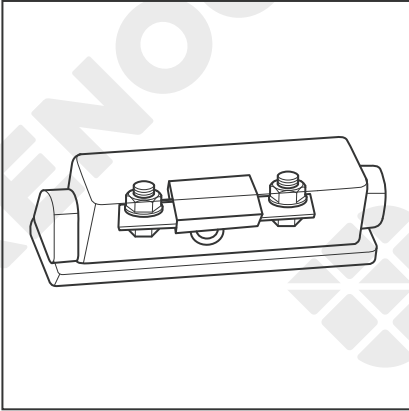

### **DC Fuse (400A)**

The DC fuse protects the inverter charger, wires and batteries from overcurrent.

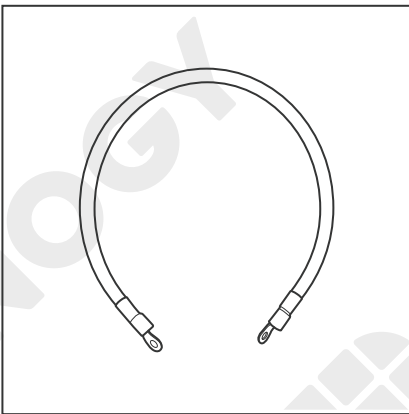

### **Fuse Cable 4/0 AWG**

The cable is integrated with copper rings at both ends, enabling the inverter charger to be connected with an external fuse.

# Product Overview

External View

Internal View

## External View

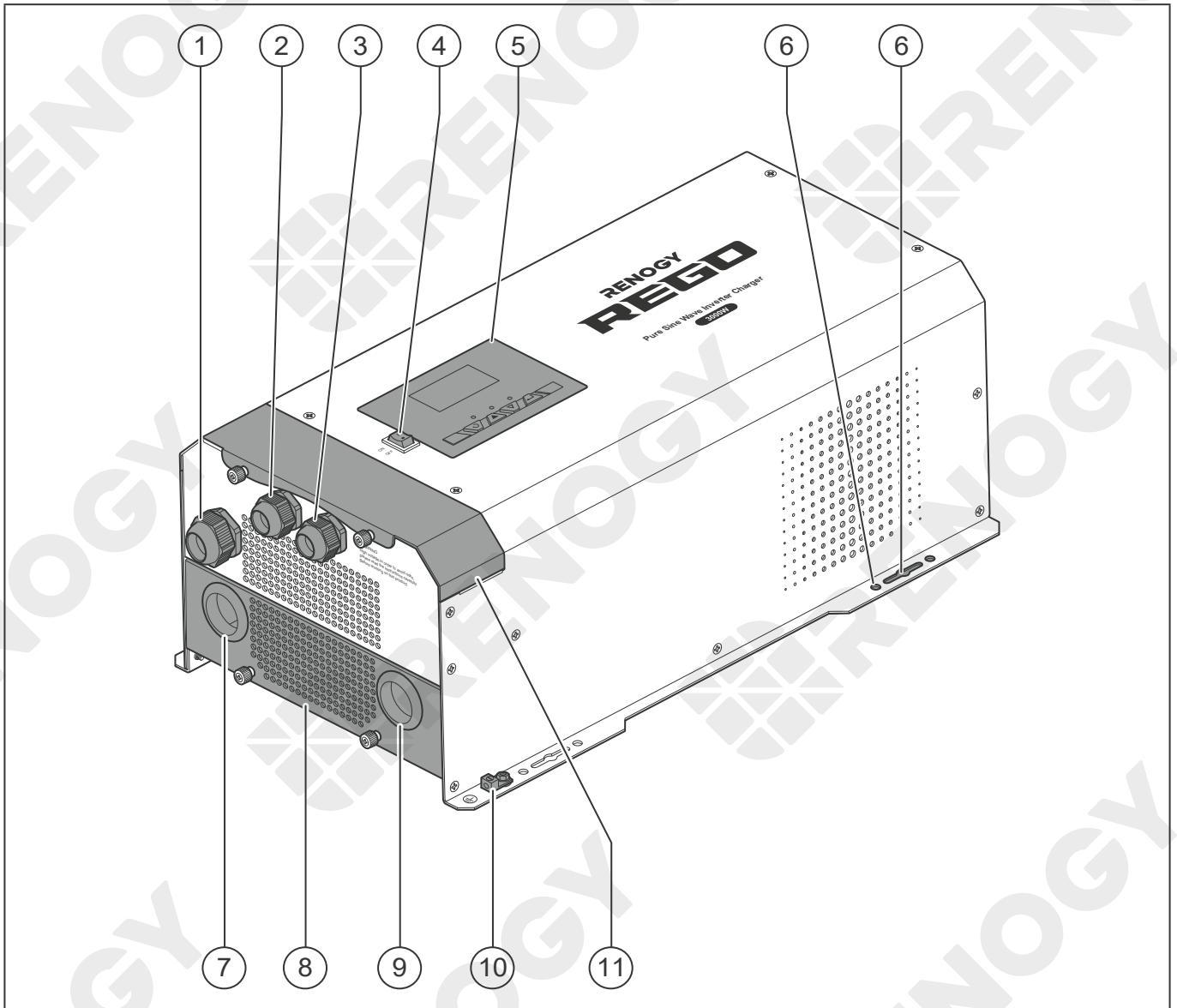

No.	Part	No.	Part
1	Remote & Accessory Cable Entry	7	DC Negative Battery Cable Entry
2	AC Output Cable Grommet	8	DC Cable Plate
3	AC Input Cable Grommet	9	DC Positive Battery Cable Entry
4	Main Power Switch	10	Chassis Ground Lug
5	LCD & Button Panel	11	Top Plate
6	Mounting Holes		

# Product Overview

External View

Internal View

## Internal View

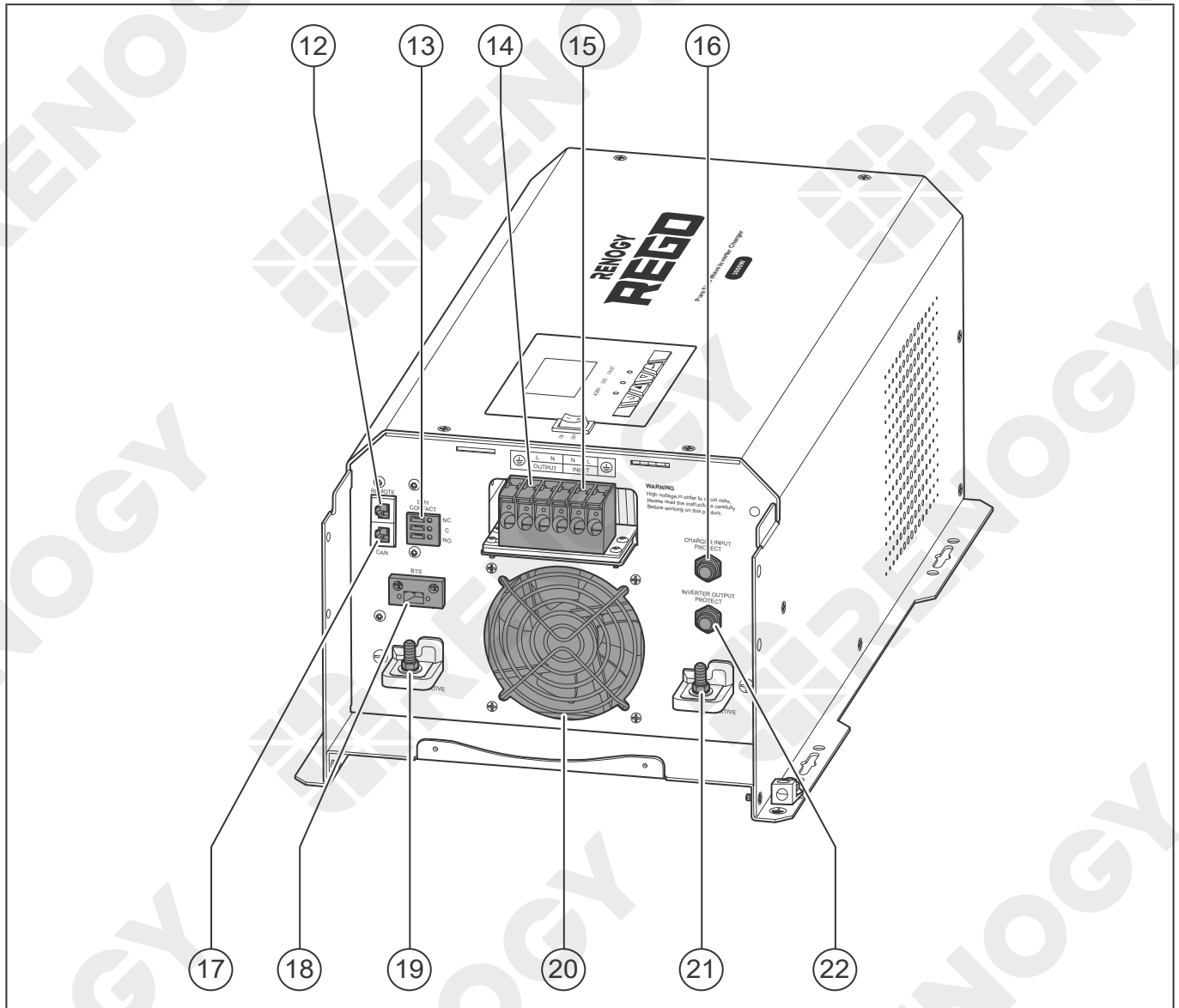

No.	Part	No.	Part
12	Wired Remote Port (REMOTE)	18	Battery Temperature Sensor (BTS) Port
13	Dry Contact Relay Terminal Block	19	DC Negative Battery Terminal
14	AC Output Lever Terminal Block	20	Fan
15	AC Input Lever Terminal Block	21	DC Positive Battery Terminal
16	Input Circuit Breaker	22	Output Circuit Breaker
17	Communication Port (CAN Bus)		

# Wiring Diagram

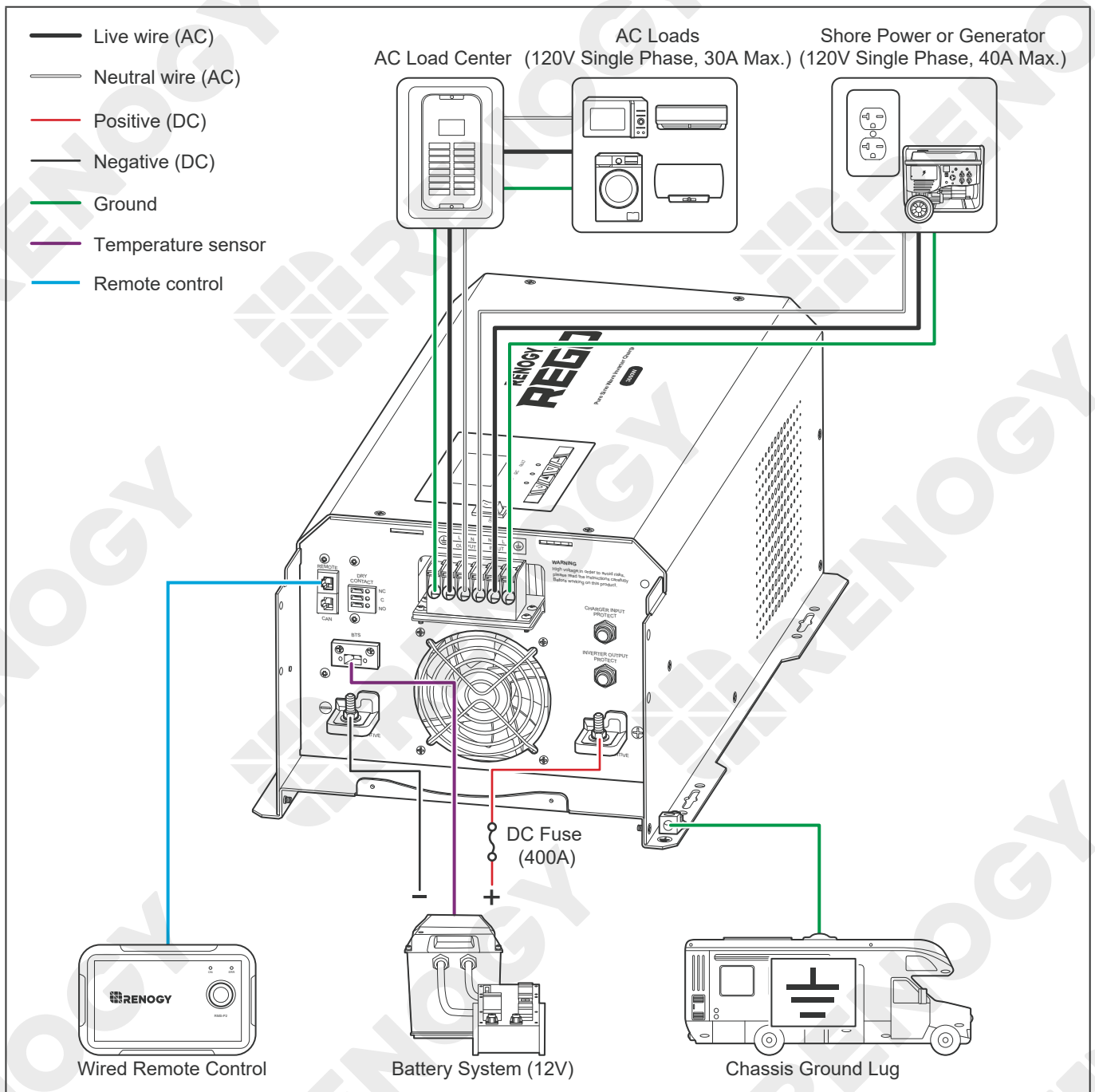

## **i** NOTE

- Do not use the temperature sensor on a LiFePO4 (LFP) battery which comes with a Battery Management System (BMS).

# Recommended Cable Sizing

Cable	Cable Length (ft) / (m)	Recommended Cable Size
AC Output	0 ft to 10 ft (0 m to 3 m)	8 AWG
	11 ft to 20 ft (3 m to 6 m)	6 AWG
	21 ft to 30 ft (6 m to 9 m)	6 AWG
AC Input	0 ft to 10 ft (0 m to 3 m)	8 AWG
	11 ft to 20 ft (3 m to 6 m)	6 AWG to 8 AWG
	21 ft to 30 ft (6 m to 9 m)	6 AWG

**i** **NOTE**

- The cable specifications listed above account for critical, less than 3% voltage drop and may not account for all configurations.

# Components & Tools



## CAUTION

- The adapter cable used in this manual can be made by yourself or purchased from [renogy.com](http://renogy.com) by searching names in Recommended Components.

## Recommended Components

Battery Scenario A: REGO Battery Kit

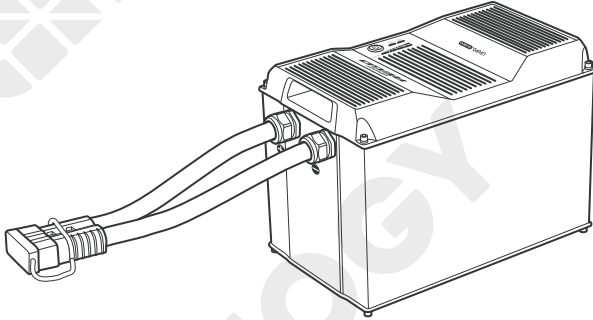
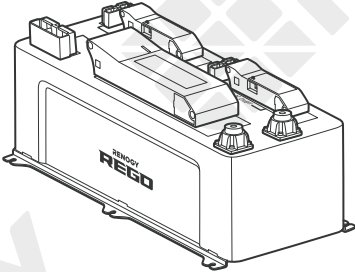
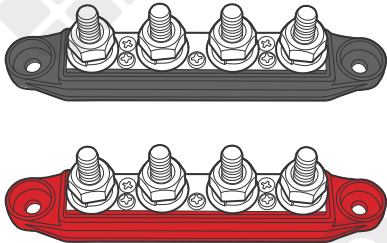
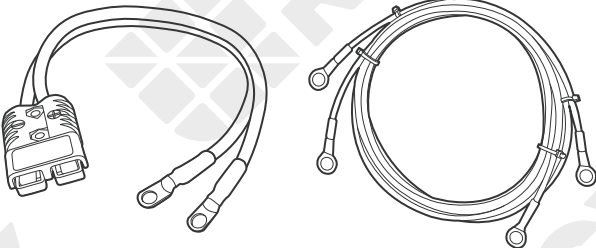
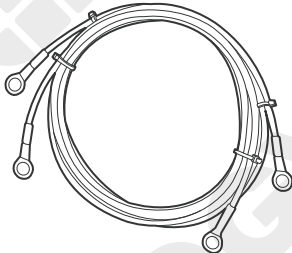

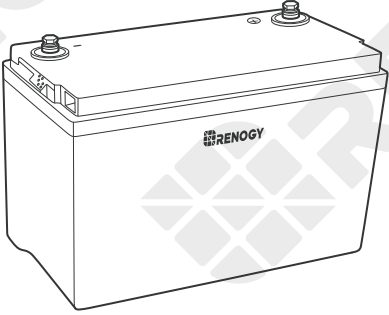
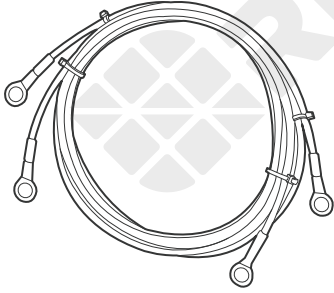

REGO 12V 400Ah Lithium Iron Phosphate Battery	
	
System Combiner Box Accessory Set	Positive / Negative Busbars Accessory Set
REGO 4 Ports 400A System Combiner Box	Positive / Negative Busbars
	
Battery Adapter Cable 4/0 AWG (Anderson 350 Connector to Ring Terminal Adapter Cable or Ring Terminal Adapter Cable)	Battery Inverter Cable 4/0 AWG (Ring Terminal Adapter Cable)
	

# Components & Tools

## Battery Scenario B: Normal Battery Kit

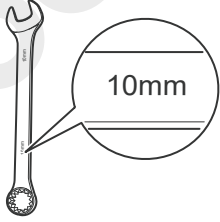
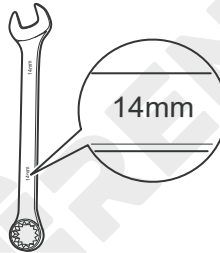
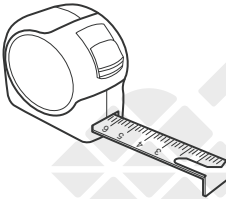
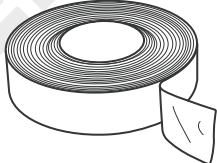
Normal Battery with +/- Bolts	Battery Inverter Cable 4/0 AWG (Ring Terminal Adapter Cable)
	

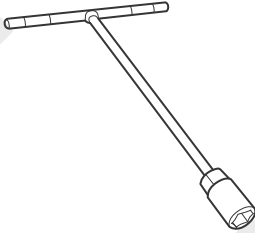
## Required Tools

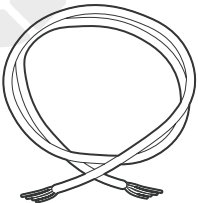
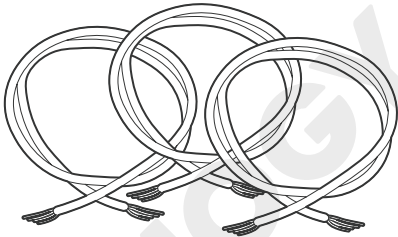
Wrench (10 mm)	Wrench (14 mm)	Measuring Tape	Insulation Tape
			
Phillips Screwdriver (6 mm)	Slotted Screwdriver (6 mm)	Socket Wrench (12 mm)	Wire stripper
			
Bare Wire			
Grounding (6 AWG to 8 AWG)		AC Output x 3	
			



# Components & Tools

## NOTE

- The AC Output Cable Grommet has an inner diameter of 13 mm. Properly select the AC cable size and ensure it can run through the grommet.
- The DC Positive/Negative Terminals use M8 Studs. Select the appropriate ring terminal.
- Read [Recommended Cable Sizing](#) in this manual, and select the appropriate cables according to actual use.

## Inspecting Inverter Charger

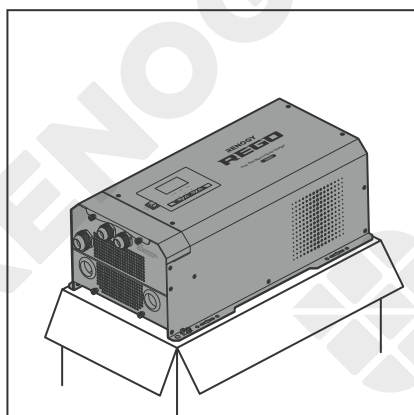

1. Inspect the inverter charger for any visible damage including cracks, dents, deformation, and other visible abnormalities. All connector contacts shall be clean, dry, and free of dirt and corrosion.

### **WARNING**

- Do not use the inverter charger if it has any visible damage.

## Environment

Install the inverter charger on a flat surface indoors protected from direct sunlight, high temperature, and water. Make sure there is good ventilation.

Make sure that the inverter charger is installed in a place at ambient temperature from -4°F to 104°F or -20°C to 40°C and relative humidity between 0% and 95% no condensation.

### **NOTE**

- Install the inverter charger as close to the battery as possible to avoid voltage drops due to long cables.

### **WARNING**

- Risk of explosion! Never install the inverter charger in a sealed enclosure with flooded batteries! Do not install it in a confined area where battery gases can accumulate.

# Inspection

## Placement

The inverter charger can be fixed vertically (terminals facing down) to a wall or horizontally to the floor.

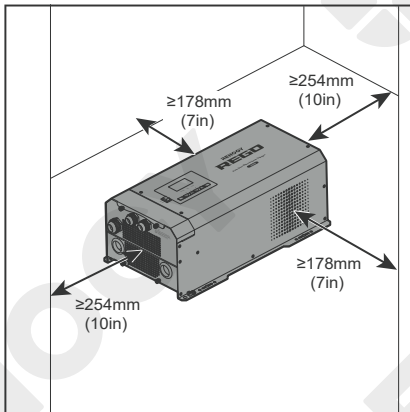
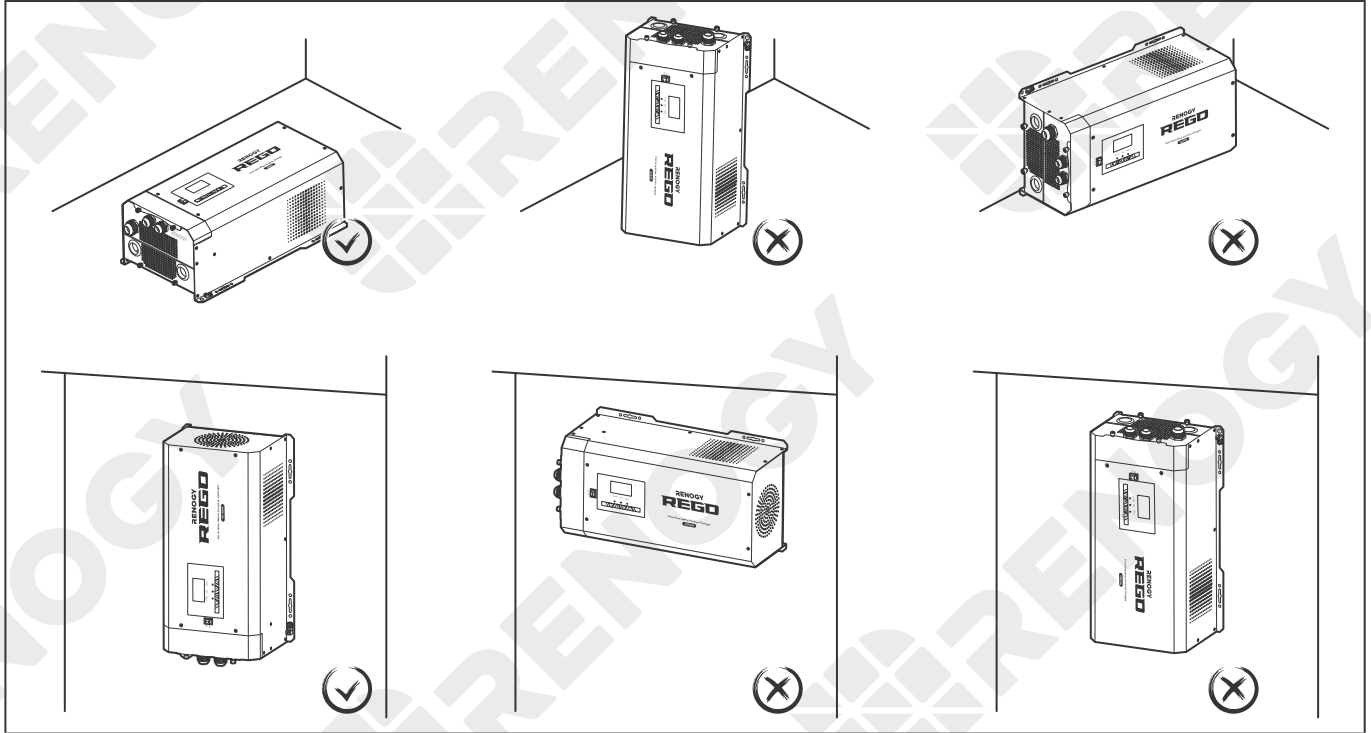

1. Ensure enough space to avoid tangles and kinks of cables. Allow at least 10 inches of clearance at the fan and at least 7 inches around each side. It is better to have a larger ventilation gap. Do not obstruct the fan openings.

# Inspection

Inspecting Inverter Charger

Environment

Placement

Checking Battery

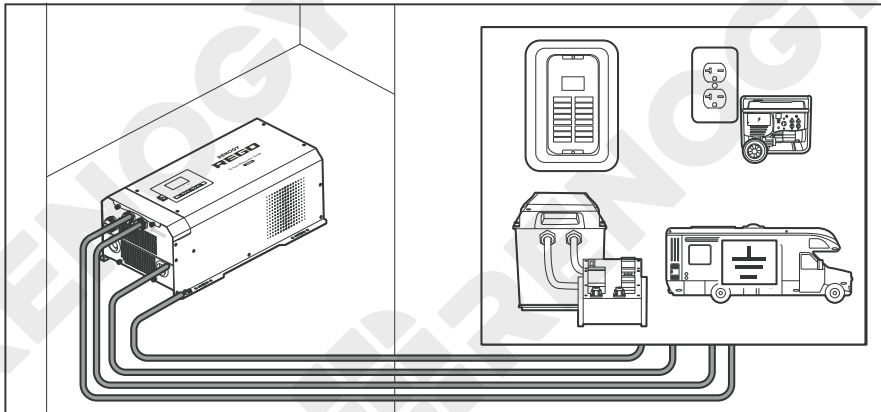

2. Measure the length of the adapter cable to make sure it can be connected to the inverter charger.

## NOTE

- If the adapter cable is not long enough, reselect the installation site.

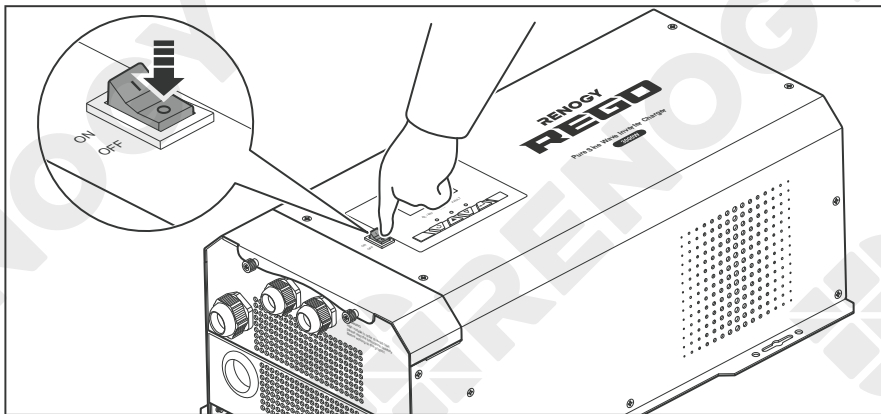

3. After the installation site is determined, rock the main switch of the inverter charger to the "OFF" position and keep it until the inverter charger is ready to be powered on.

## Checking Battery

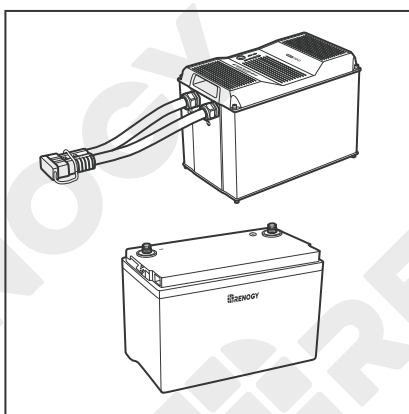

1. Inspect the battery for any visible damage including cracks, dents, deformation, and other visible abnormalities. All connector contacts shall be clean, dry, and free of dirt and corrosion.

## INFO

- Read the user manual of the battery carefully before installation.

# Inspection

## NOTE

- Make sure the battery is working normally.
- Battery types supported by the inverter charger: AGM/Gel/SLA/Open Lead Acid Flooded/Calcium/De-sulphation/Li.
- Take care to use a high-capacity lead-acid battery. Be sure to wear protective goggles. If carelessly getting electrolyte in your eyes, flush your eyes with clean water immediately.

## CAUTION

- Comply with local, state, and federal laws and regulations and use recycling channels as required when disposing of unwanted batteries.

## WARNING

- Do not use the battery if it has any visible damage.
- Do not touch the exposed electrolyte or powder if the battery housing is damaged.
- When being charged, the battery may give off explosive gas. Make sure there is good ventilation.

Battery or Battery Bank System Voltage	
Battery or Battery Bank System Voltage = System Voltage U	
Batteries in Series	Batteries in Parallel
System Voltage U: $U_1+U_2+U_3$	System Voltage U: $U_1=U_2=U_3$

2. Combine batteries in parallel or in series as needed. This inverter charger supports 12V batteries. Read the user manual for battery voltage parameters, and calculate the battery or battery bank system voltage according to the formula to ensure that it is 12V.

## NOTE

- In the formula, U represents the battery voltage, and 1, 2 or 3 represents the battery number respectively.

## WARNING

- Do not use the inverter charger if the battery/battery bank system voltage exceeds 12V. Doing so will cause damage to the inverter charger.

# Preparation

Mounting

Removing the Plate

Cautions

## Mounting

### Recommended Accessories

#### Self-tapping Screws (M8 or M6)

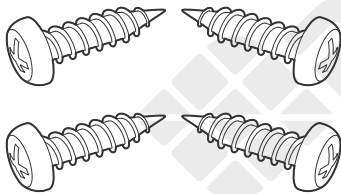

### **i** NOTE

- Choose proper self-tapping screws to adapt to the installation site.
- Make sure the inverter charger is firmly mounted on the installation site to prevent it from sliding or falling off.

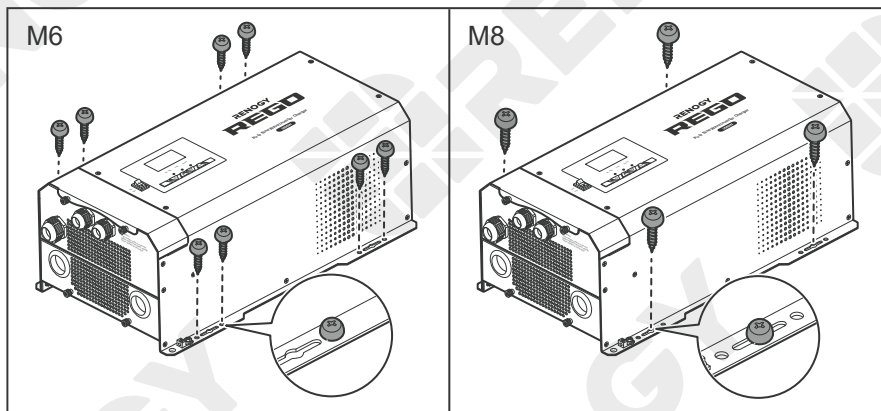

Align the inverter charger with the mounting position to fix it with self-tapping screws through the mounting holes.

## Removing the Plate

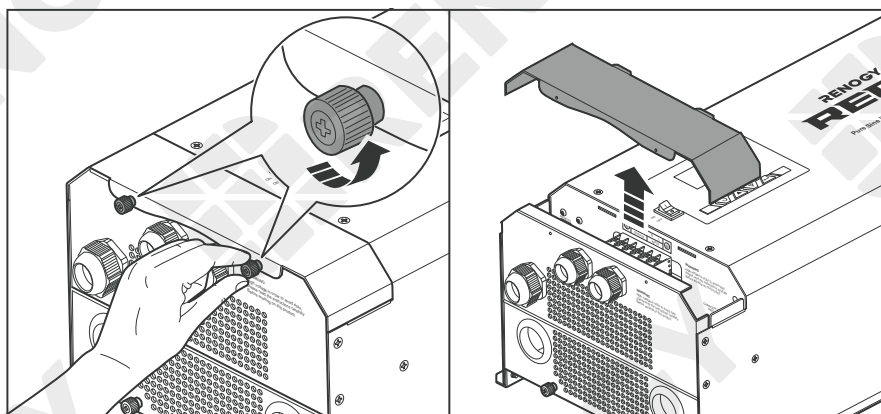

1. Turn the two upper panel screws counterclockwise by hand or a Phillips screwdriver, and remove the Top Plate.

# Preparation

Mounting

Removing the Plate

Cautions

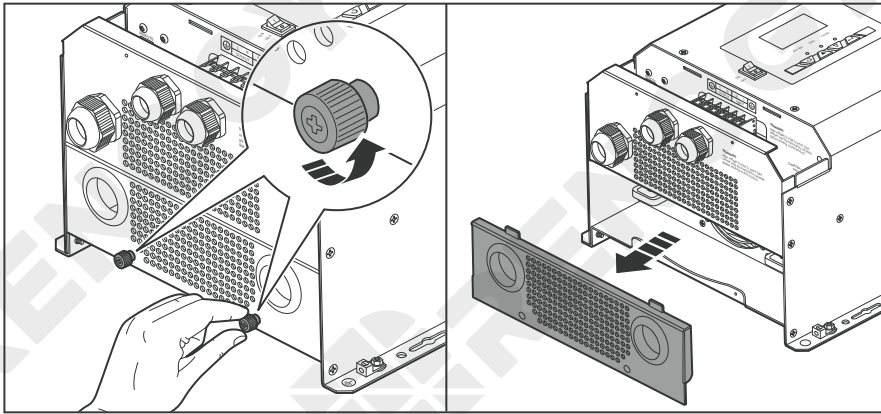

2. Turn the two screws on the lower panel counterclockwise by hand or a Phillips screwdriver, and remove the DC Cable Plate.

## Cautions

### **i** NOTE

- All wiring should be done by qualified personnel to ensure compliance with all applicable installation code and regulations.
- Wear proper protective equipment and use insulated tools during installation.
- Ensure that all ring terminals are securely connected.
- Make sure all cables have a smooth bend radius and no kinks are present.
- Color code and label all AC Cables coming to/from the inverter charger. Use colored electrical tape or heat shrink tubing.

### **!** WARNING

- Risk of electric shock! Ensure that all power sources are disconnected before installation.
- Make sure that all adapter cables are not connected to any device before connection. If they are connected, make sure that all power devices are powered off.
- Identify the polarities (positive and negative) on the cables used for batteries. A reverse polarity contact will damage the inverter charger and void the warranty.
- Do not connect the AC Load Output to an AC Power Source such as generator or shore power. Otherwise, severe damage may occur.

# Ground Cable Wiring

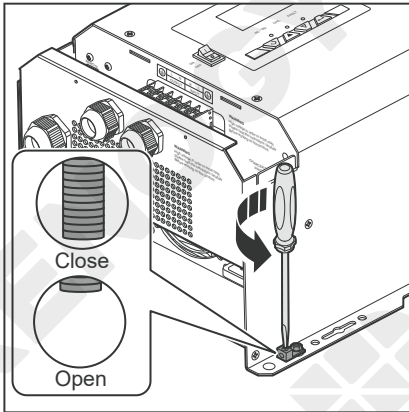

1. Turn the cable retainer screws for the Chassis Ground Lug counterclockwise with a slotted screwdriver to ensure that the cable retainer is open.

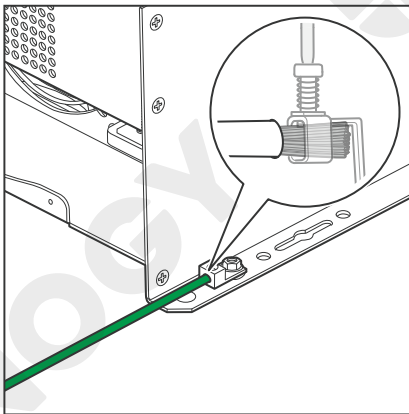

2. Insert one end of the bare wire into the wiring hole of the Chassis Ground Lug.

## **i** NOTE

- Strip some insulation off the grounding cable by using a wire stripper according to the depth of the wiring hole.

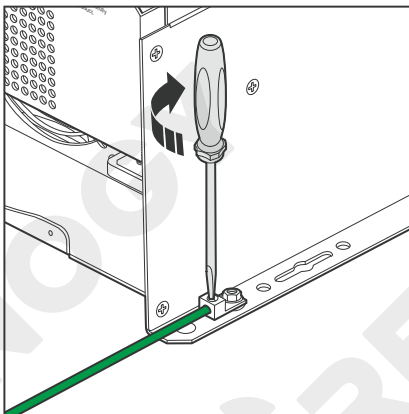

3. Tighten the cable retainer screws for the Chassis Ground Lug clockwise with a slotted screwdriver to fasten the cable.

## **i** NOTE

- The torque of the cable retainer screw is 13.5 N·m. Do not overtighten it to prevent damage.

# Ground Cable Wiring

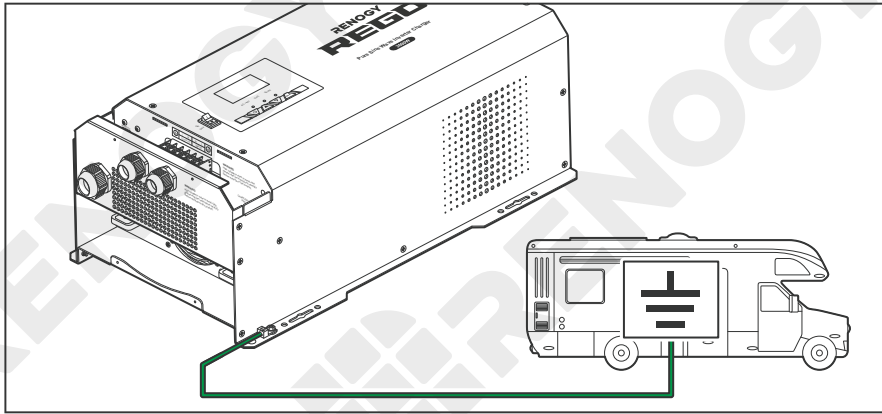

4. Connect the other end of the bare cable to the Chassis Ground Lug of the RV.

## INFO

- When connecting the inverter charger to the chassis ground lug of your RV, consult the RV supplier to confirm the location of the chassis ground lug. A connection terminal can be installed if needed.

# Remote Control Wiring

You may choose to use the wired remote control of the inverter charger.

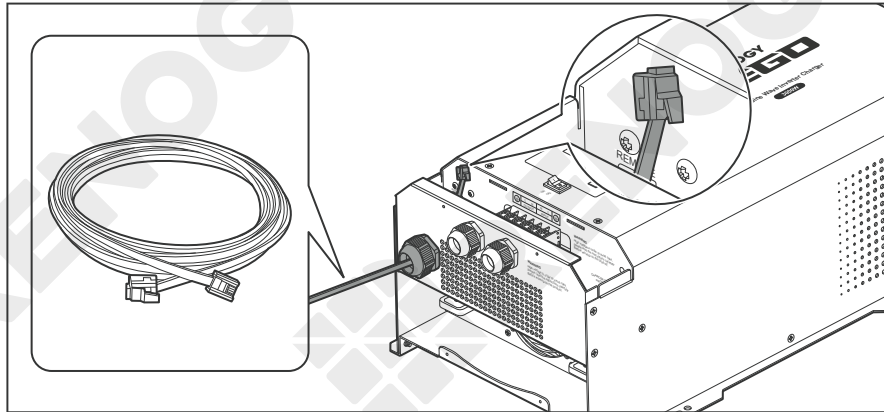

1. Run one end of the included RJ11 cable through the Remote & Accessory Cable Entry.

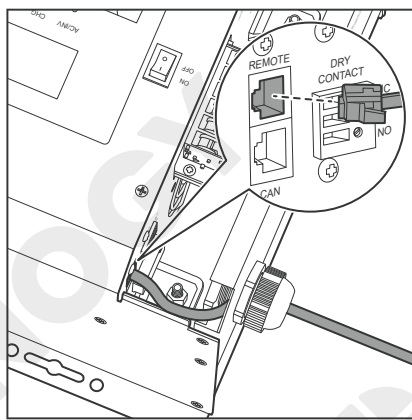

2. Connect the connector to the Wired Remote Port (REMOTE).

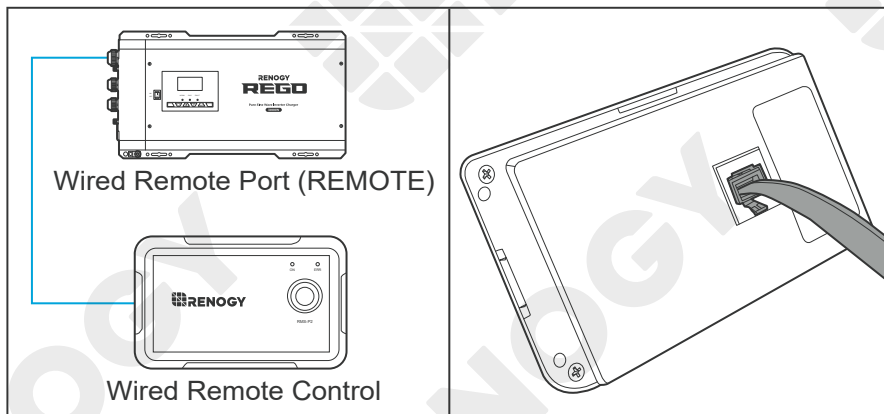

3. Connect the connector on the other end of the RJ11 cable to the Wired Remote Control.

# Temperature Sensor Wiring

The temperature sensor measures the temperature of the battery and provides the inverter charger with a charge voltage calibration mechanism to ensure that the inverter charger can properly charge the battery within the operating temperature from  $-4^{\circ}\text{F}$  to  $140^{\circ}\text{F}$  or  $-20^{\circ}\text{C}$  to  $60^{\circ}\text{C}$ .

## NOTE

- Do not use the temperature sensor on a LiFePO<sub>4</sub> (LFP) battery which comes with a battery management system (BMS).
- There is no requirement on polarity for temperature sensor cables.

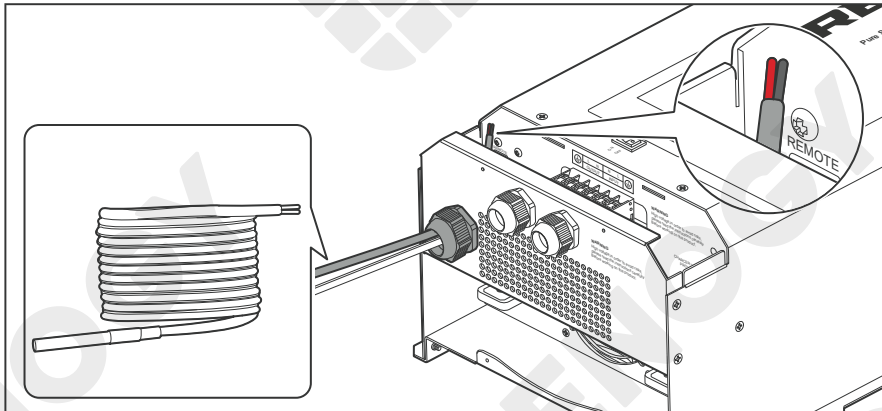

1. Run the bare terminal of the temperature sensor through the Remote & Accessory Cable Entry.

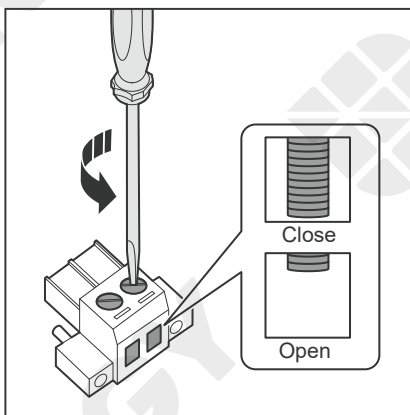

2. Turn the cable retainer screws for wire harness connector counterclockwise with a slotted screwdriver to ensure that the cable retainer is open.

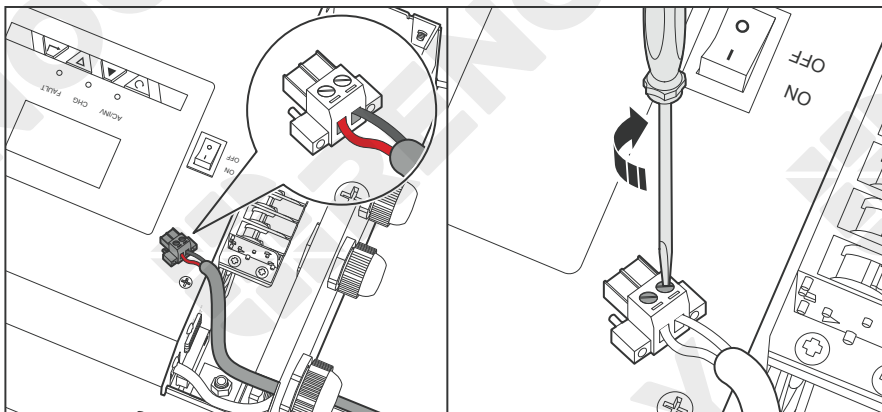

3. Insert the bare terminal of the temperature sensor into the harness connector and tighten it with a slotted screwdriver by turning the cable retainer screw for wire harness connector clockwise.

## NOTE

- Strip some insulation off the grounding cable with a wire stripper.

# Temperature Sensor Wiring

- Do not overtighten the cable retainer screws. Otherwise it will lead to stripped screws or screw bending.

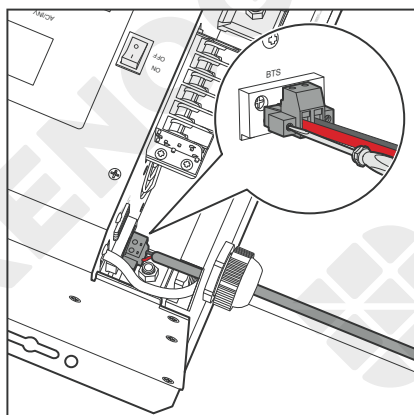

4. Plug the harness connector into the BTS Port of the inverter charger.

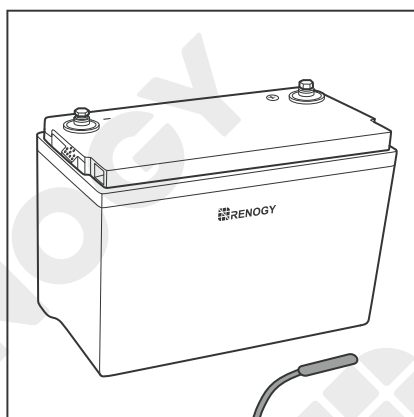

5. Place the temperature sensor near the battery and fix it with a cable tie or insulation tape if necessary.

# Battery Wiring

Device-side Wiring

Battery-side Wiring

## Device-side Wiring

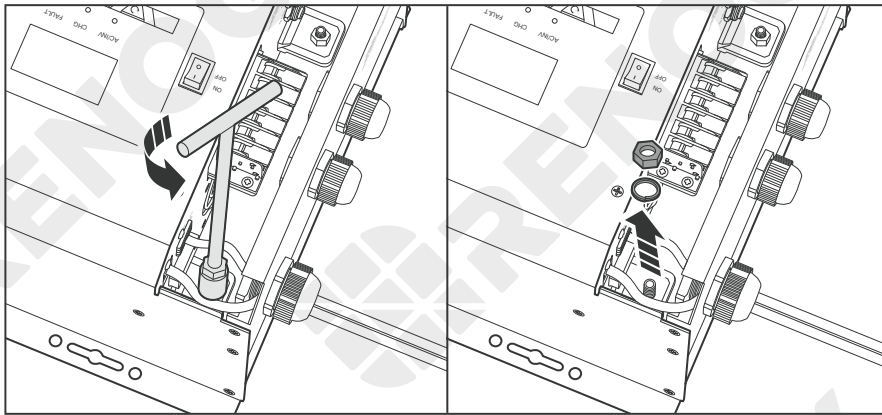

1. Remove the retaining nut of the DC Negative Battery Terminal by turning it counterclockwise with a socket wrench and then remove the gasket.

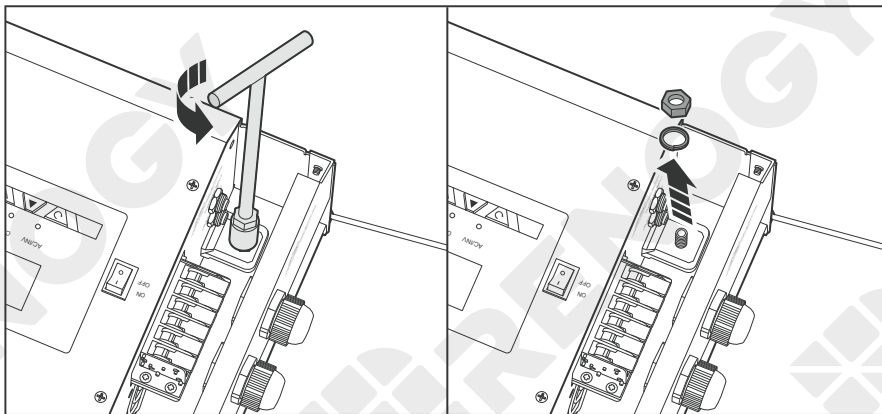

2. Remove the retaining nut of the DC Positive Battery Terminal by turning it counterclockwise with a socket wrench and then remove the gasket.

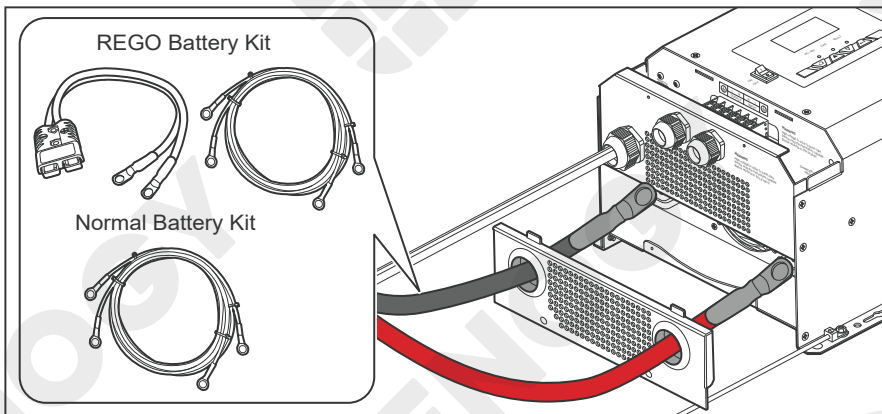

3. Insert the positive ring terminal of the battery adapter cable through the DC Positive Battery Cable Entry, and the negative ring terminal through the DC Negative Battery Cable Entry.

### NOTE

- Select appropriate battery adapter cables based on your needs.

# Battery Wiring

Device-side Wiring

Battery-side Wiring

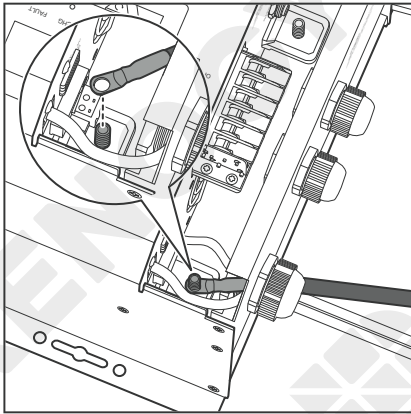

4. Connect the negative ring terminal to the DC Negative Battery Terminal.

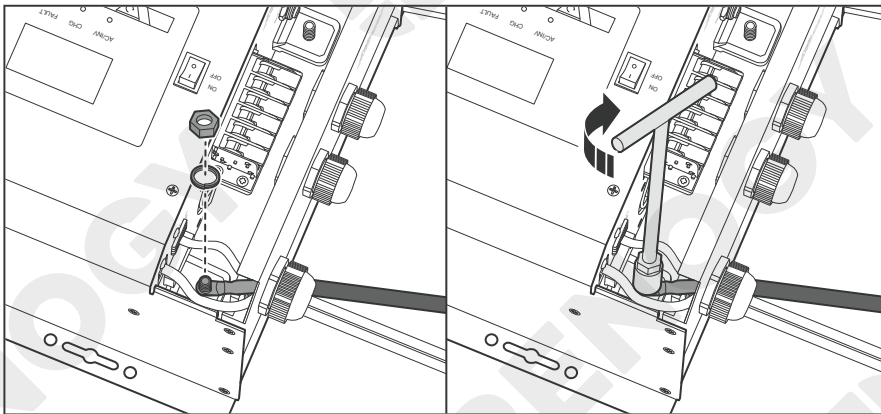

5. Install the gasket and the retaining nut, and tighten the nut clockwise with a socket wrench.

## **i** NOTE

- The retaining nut torque of the DC Negative Battery Terminal is 26 N·m. Do not overtighten it to prevent damage.

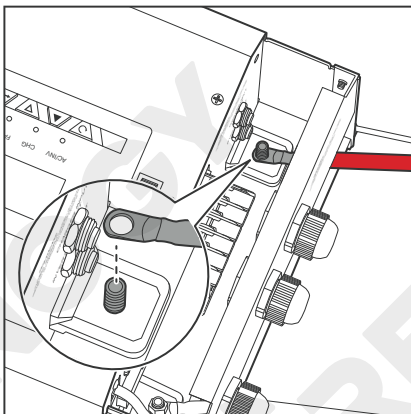

6. Connect the positive ring terminal to the DC Positive Battery Cable Entry.

# Battery Wiring

Device-side Wiring

Battery-side Wiring

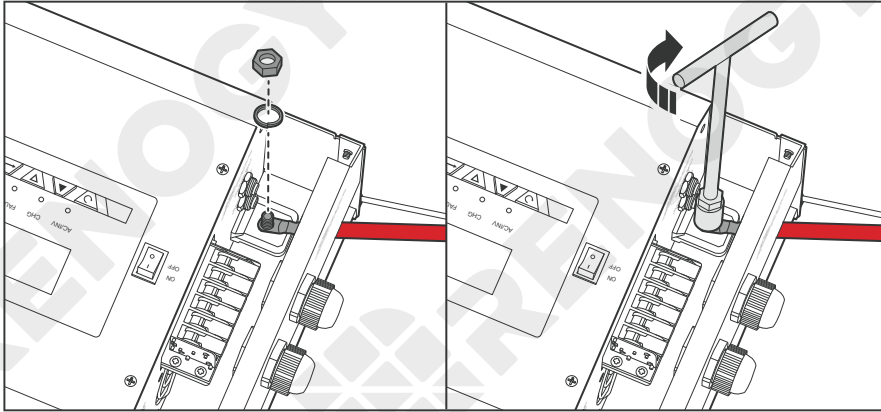

7. Install the gasket and retaining nut, and tighten the nut clockwise with a socket wrench.

## **i** NOTE

- The retaining nut torque of the DC Positive Battery Terminal is 26 N·m. Do not overtighten it to prevent damage.

## Battery-side Wiring

## **i** NOTE

- Identify the polarities (positive and negative) on the cables used for the batteries. A reverse polarity contact may damage the inverter charger.
- Ensure that the Anderson connectors are fully seated and/or the ring terminals are securely connected.

## **!** WARNING

- Do not touch the positive and negative terminals of the battery directly with your hands at the same time.
- Do not allow the positive (+) and negative (-) terminals of the battery to contact with each other.

# Battery Wiring

Device-side Wiring

Battery-side Wiring

## Battery Scenario A: REGO Battery Kit

### INFO

- Read the REGO 4 Ports 400A System Combiner Box User Manual carefully before connection.
- **Using Battery Adapter Cable (Anderson 350 Connector to Ring Terminal Adapter Cable)**

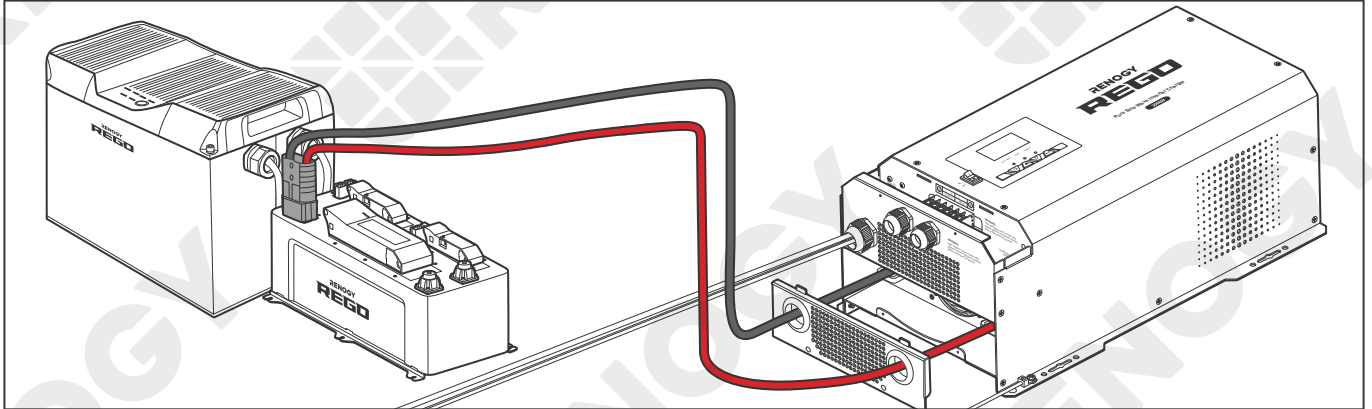

1. Connect the Anderson 350 connector of the battery adapter cable to the System Combiner Box.

### NOTE

- When connecting the combiner box to the inverter charger via the system hub of Anderson connector, install a 400A NH fuse in the top disconnection switch.

### ■ **Using Battery Adapter Cable (Ring Terminal Adapter Cable)**

### NOTE

- Select the appropriate wrench according to positive/negative wire fixing bolt specifications of the system hub.

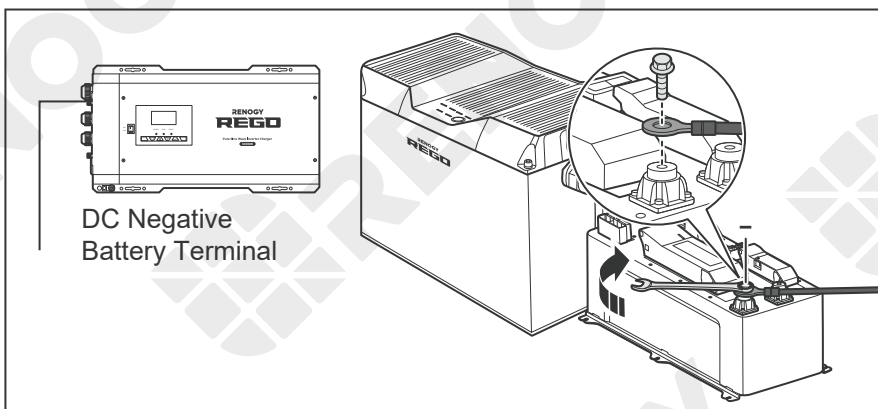

1. Connect the negative ring terminal to the negative terminal of the system hub. Tighten the wire retaining bolt with a wrench.

# Battery Wiring

Device-side Wiring

Battery-side Wiring

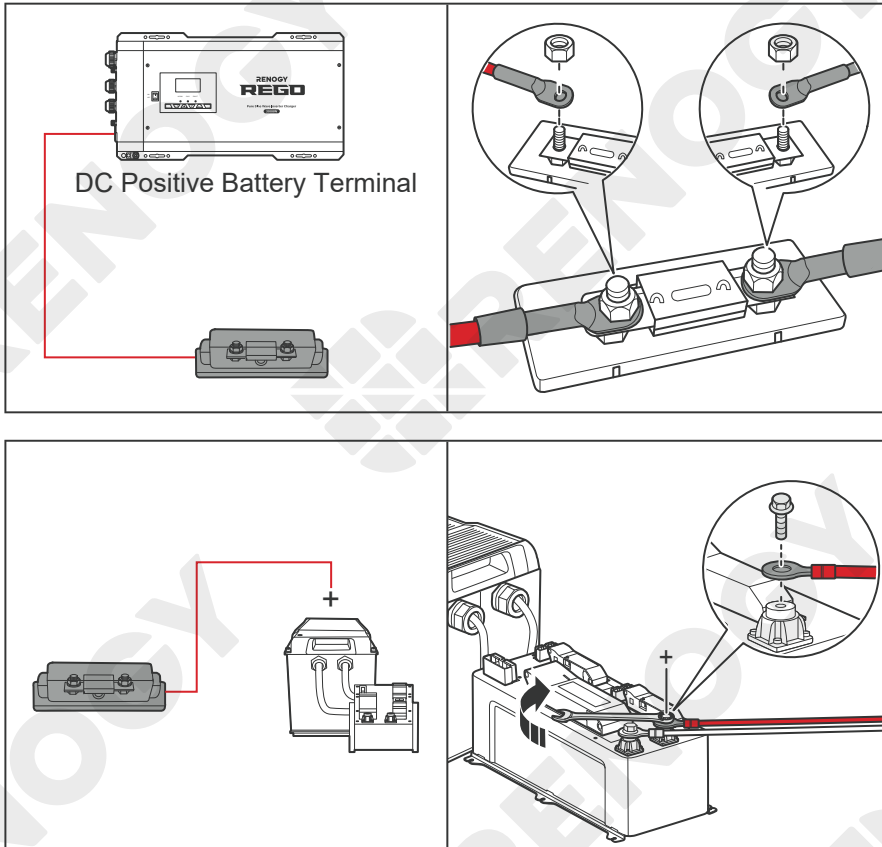

2. For your safety, it is recommended to use a DC fuse (400A). Connect the positive ring terminal to the DC fuse. Install the fuse cable on the other end of the fuse.

3. Attach the other ring terminal of the other end of fuse cable to the positive terminal of the system hub and tighten the wire retaining bolt with a wrench.

## ■ Using Positive/Negative Busbars Accessory Set

### **i** NOTE

- Select the applicable wrench according to wire fixing bolt specifications of Positive/Negative Busbars.

### **!** WARNING

- Select the right size of positive/negative sink according to the maximum continuous charging/discharging current of the battery operation.

## Essential Accessories

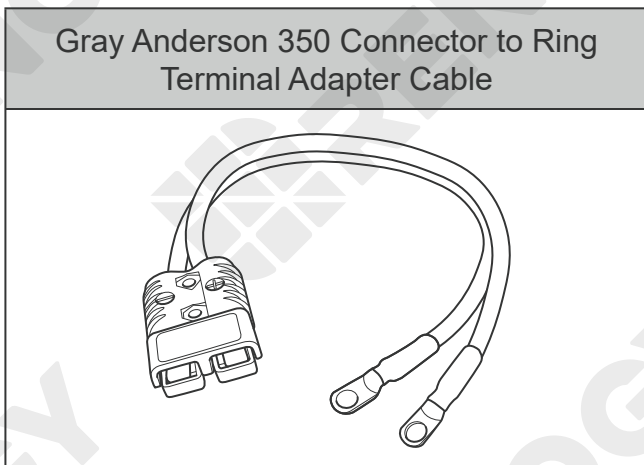

# Battery Wiring

Device-side Wiring

Battery-side Wiring

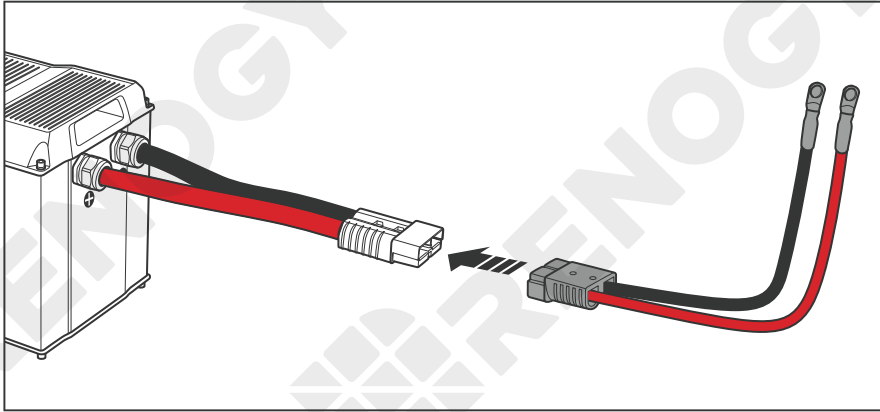

1. Connect the Anderson Connectors of the batteries to the Adapter Cables (sold separately).

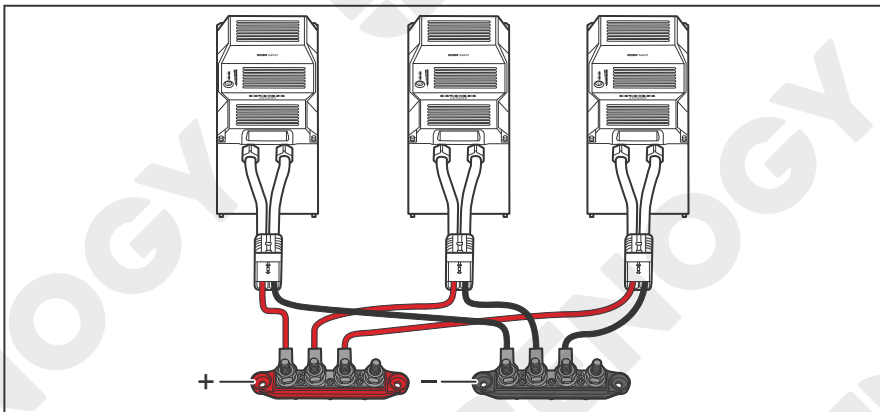

2. Connect the positive and negative ring terminals of the Adapter Cables to the Positive and Negative Busbars (not included) respectively.

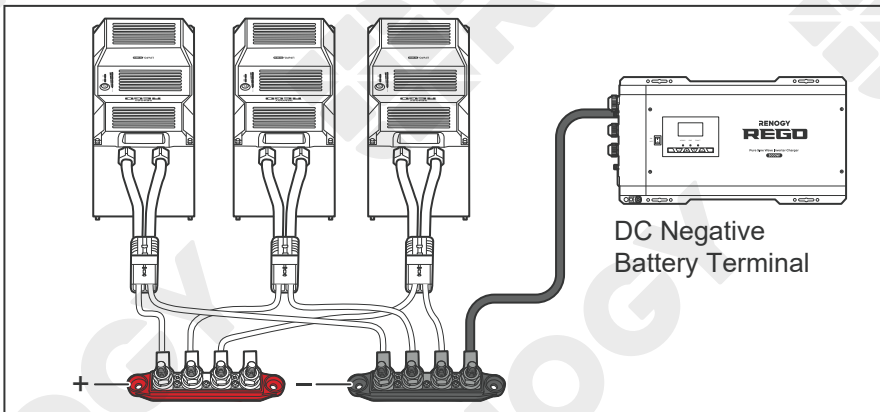

3. Attach the negative ring terminal to the Negative Busbar and tighten the wire retaining bolt with a wrench.

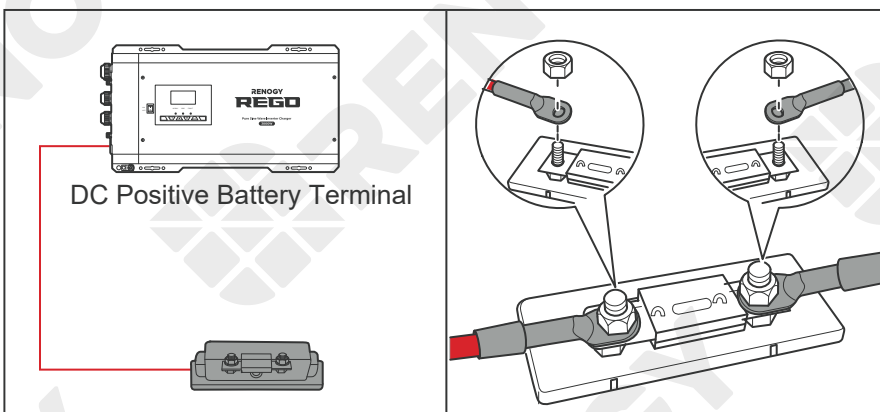

4. For your safety, it is recommended to use a DC fuse (400A). Connect the positive ring terminal to the DC fuse. Install the fuse wire on the other end of the fuse.

# Battery Wiring

Device-side Wiring

Battery-side Wiring

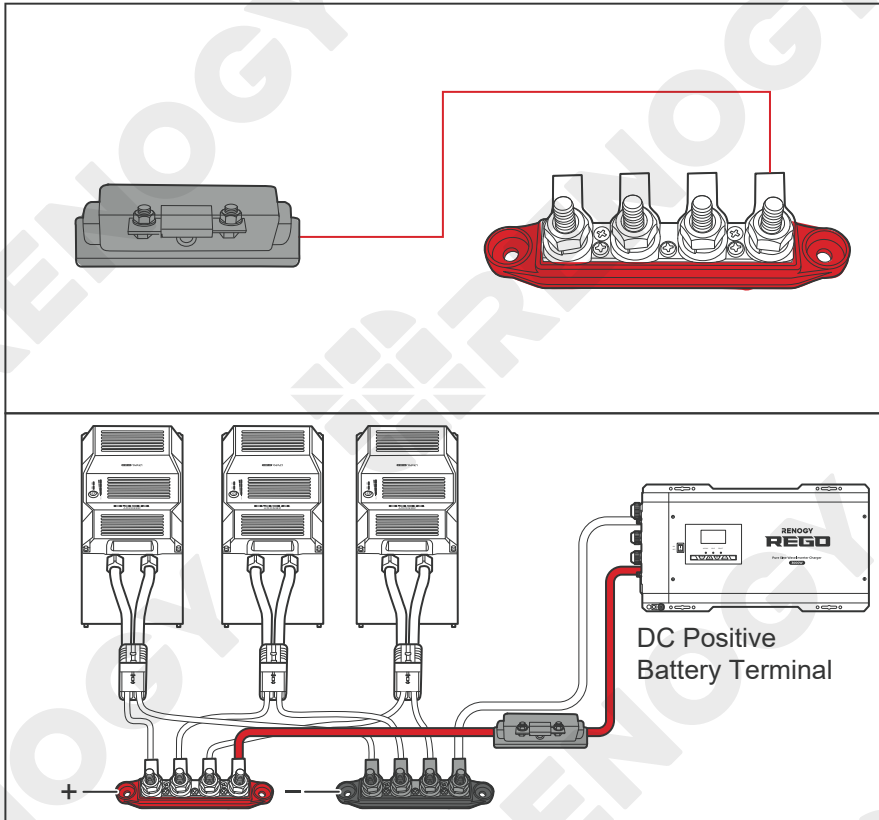

5. Attach the ring terminal of the other end of fuse cable to the Positive Busbar and tighten the wire retaining bolt with a wrench.

## Battery Scenario B: Normal Battery Kit

### **i** NOTE

- Select the appropriate wrench according to the specification of the positive/negative wire retaining bolt of the system hub.
- Ensure that the ring terminals are securely connected.

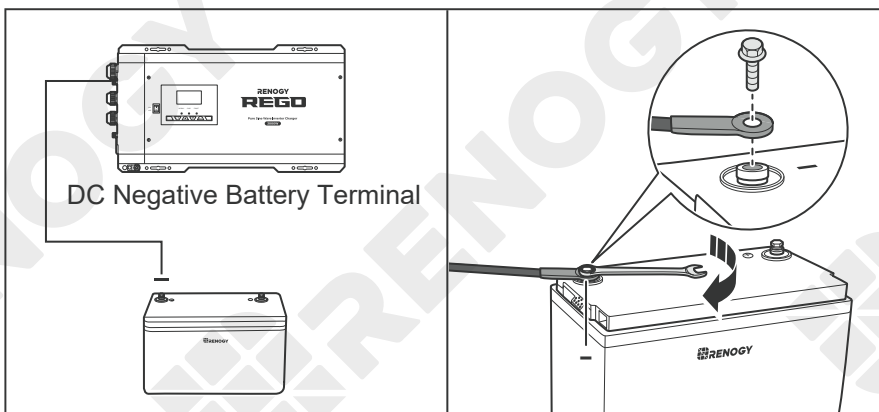

1. Connect the negative ring terminal to the negative terminal of a Normal Battery. Tighten the wire retaining bolt with a wrench.

# Battery Wiring

Device-side Wiring

Battery-side Wiring

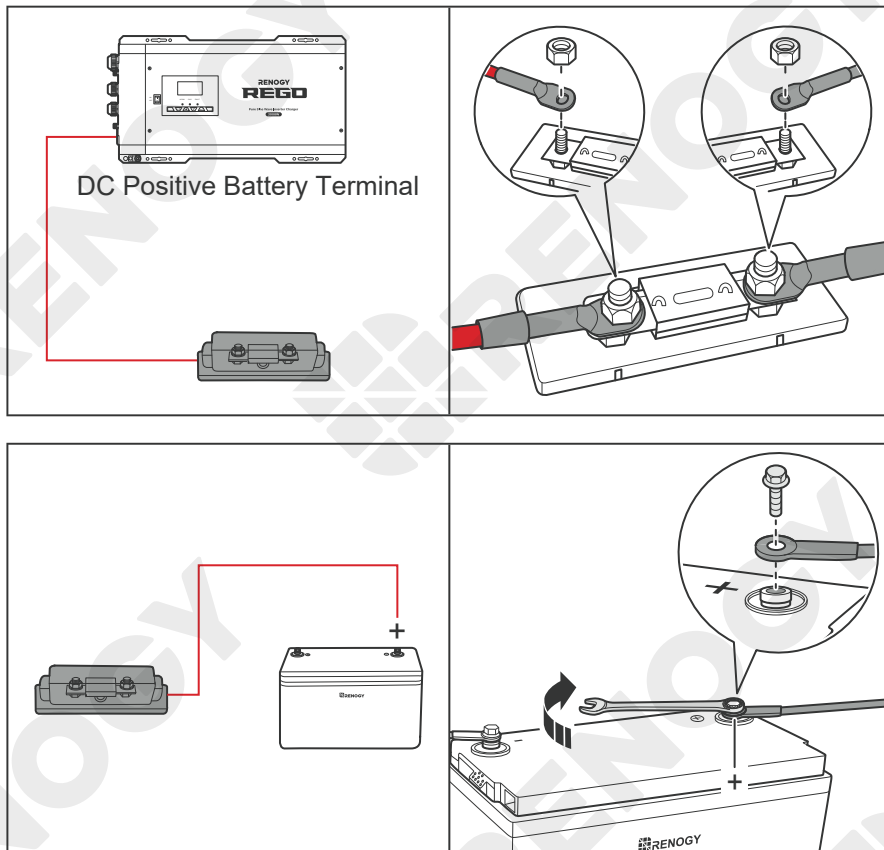

2. For your safety, it is recommended to use a DC fuse (400A). Connect the positive ring terminal of the inverter charger adapter cable to the DC fuse. Install the fuse wire on the other end of the fuse.

3. The other ring terminal of the fuse wire is connected to the positive terminal of the Normal Battery. Tighten the wire retaining bolt clockwise with a wrench.

# AC Output Wiring

Device-side Wiring

Load Wiring

## Device-side Wiring

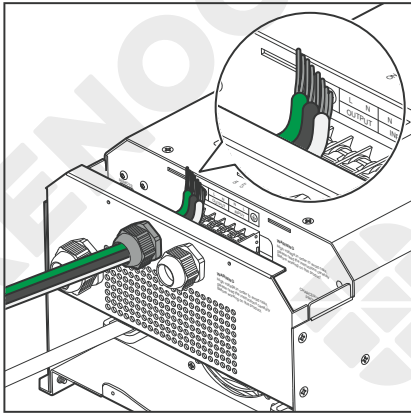

1. Run three bare wires through the AC Output Lever Terminal Block.

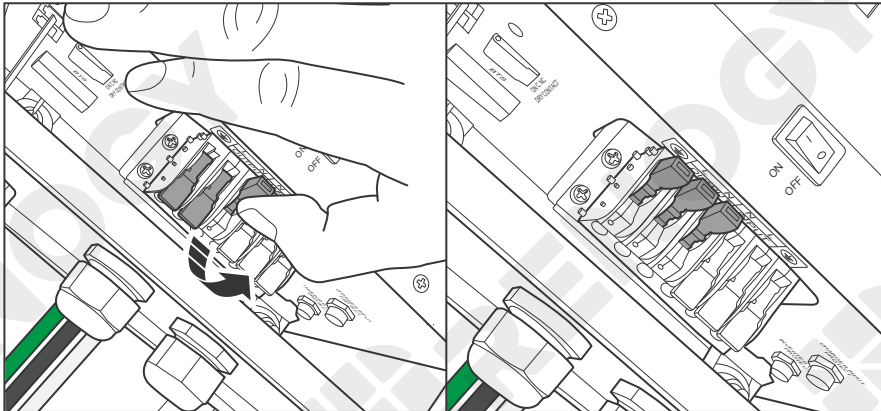

2. Push up the switches of the wire harness retainer of the AC Output Lever Terminal Block.

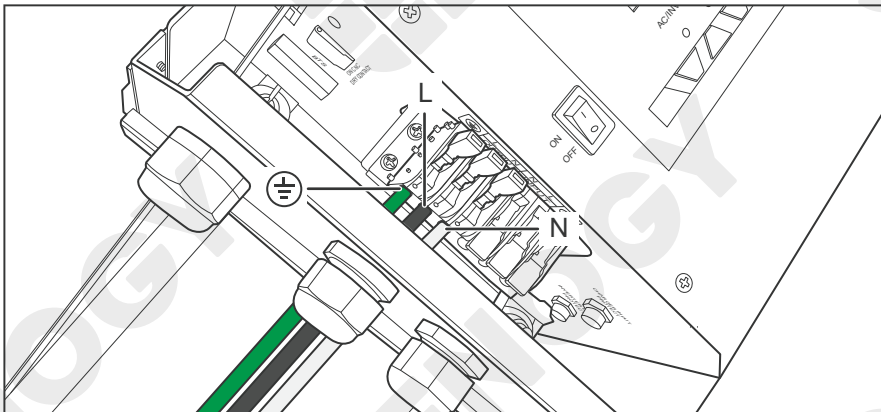

3. Connect the live wire to the (L) terminal, the neutral wire to the (N) terminal, and the ground wire to the (⊕) terminal.

### NOTE

- Strip 10 mm of insulation off the AC Output cable with a wire stripper.

# AC Output Wiring

Device-side Wiring

Load Wiring

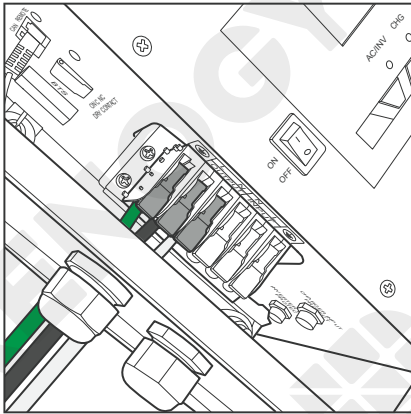

4. Press down the wire harness retainer of the AC Output Lever Terminal Block.

## **i** NOTE

- Tug at the wire to ensure a firm connection.

## Load Wiring

### Recommended Accessories

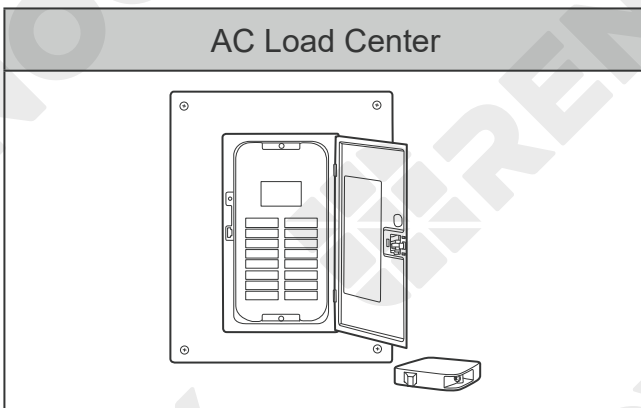

## **i** NOTE

- For your safety, it is recommended that qualified electricians familiar with safety codes of electrical systems perform the installation.

## **o** INFO

- Read the user manual of the AC load center carefully before installation.

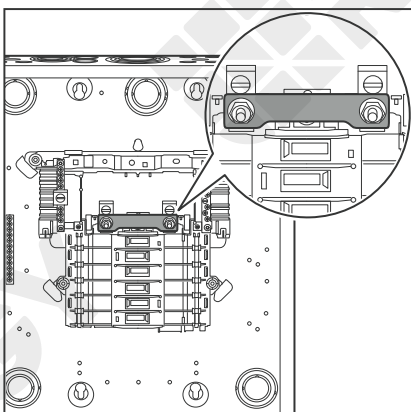

1. Remove the front cover of the AC load center and connect the two live wire busbars with a copper strip.

# AC Output Wiring

Device-side Wiring

Load Wiring

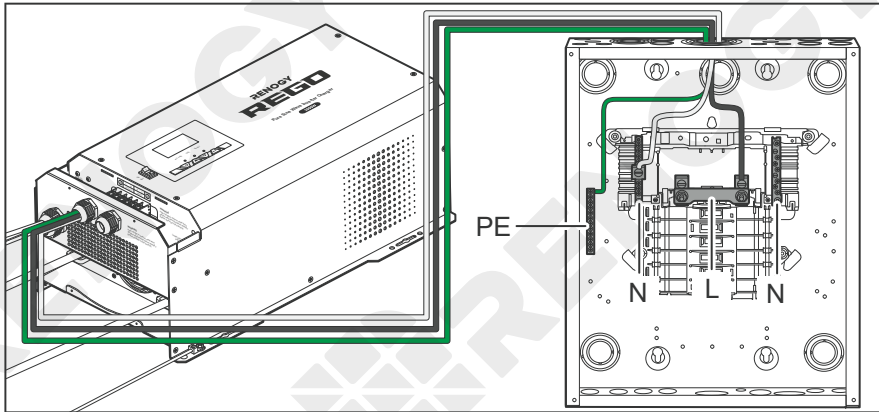

2. Connect the AC Output cable of the inverter charger to the AC load center. Connect the live wire to the (L) terminal, the neutral wire to the (N) terminal, and the ground wire to the (PE) busbar.

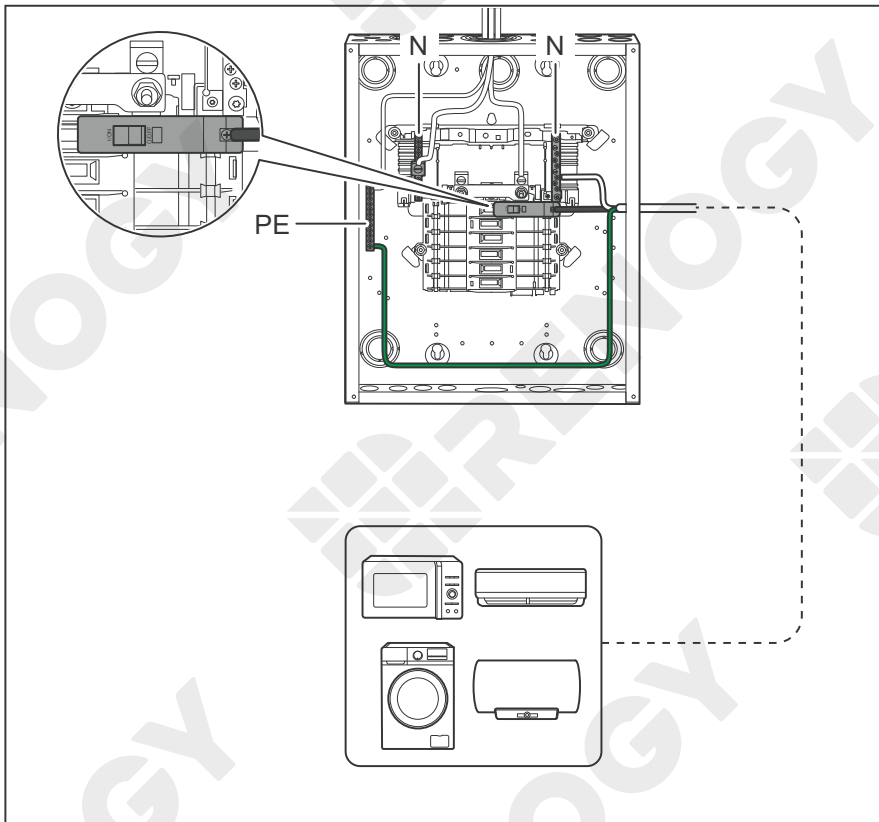

3. Select an appropriate circuit breaker according to the operating load current, and connect the load to the AC load center. Connect the live wire to the (L) terminal, the neutral wire to the (N) terminal, and the ground wire to the (PE) busbar.

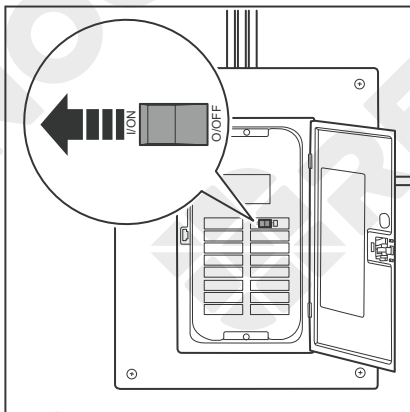

4. Install the front cover of the AC load center and turn on all the circuit breakers in the AC load center.

# AC Input Wiring

Device-side Wiring

Load Wiring

The AC input is optionally installed on demand.

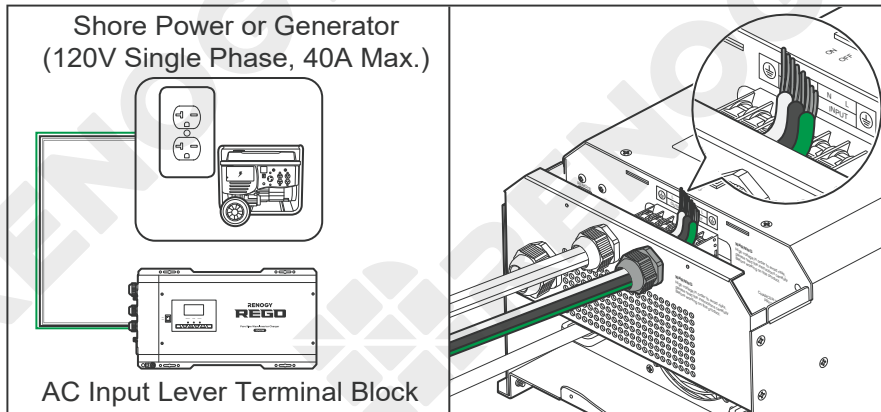

1. Run the AC power cable through the AC Input Cable Grommet.

## **i** NOTE

- The AC Input Cable Grommet has an inner diameter of 13 mm. Properly select the AC cable size and ensure that three bare wires can run through the grommet at the same time.
- Make sure the AC input current is no greater than 40A. Otherwise, the inverter charger cannot work.
- The size of the AC input cable is at least 8 AWG.

## **!** WARNING

- Risk of electric shock! Make sure the shore power or the generator is disconnected during AC input wiring.

## **o** INFO

- When connecting the inverter charger to an AC Input, read the user manual of the AC Input for wiring instructions.

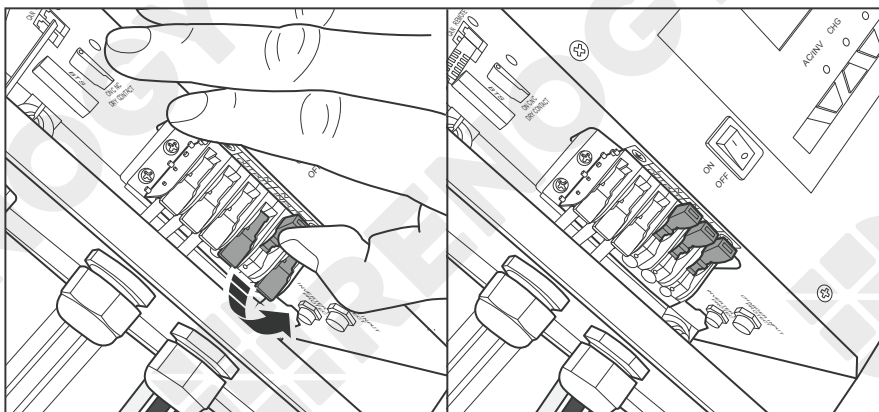

2. Push up on the lever of the AC Input Terminal Block.

# AC Input Wiring

Device-side Wiring

Load Wiring

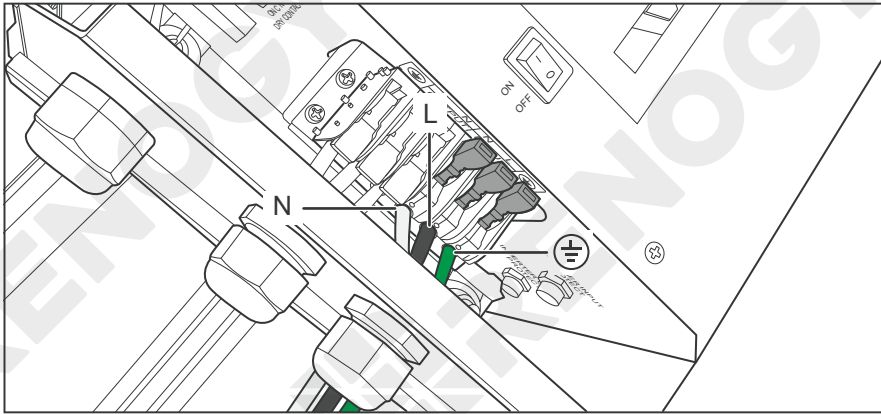

3. Connect the live wire to the (L) terminal, the neutral wire to the (N) terminal, and the ground wire to the (⊕) terminal.

## **i** NOTE

- Strip 10 mm of the insulation off the AC input cable with a wire stripper.
- You can only connect the AC input to the AC Input Lever Terminal Block. Otherwise the inverter charger will be damaged.

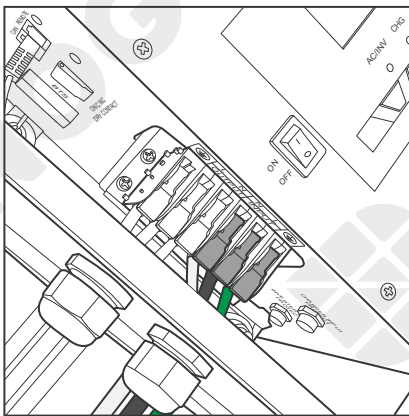

4. Press down the switch of the harness retainer of the AC Input Lever Terminal Block.

## **i** NOTE

- Tug at the wire to ensure a firm connection.

# Automatic Generator Start

If the inverter charger is connected to an AC Power Supply (AC Input) and the generator can automatically start or stop. It is recommended to connect the generator to the Dry Contact Relay Terminal Block with a signal cable.

When the voltage of the inverter charger is lower than the set voltage in Program 96, the inverter charger will automatically start the generator and charge the battery while the load is supplied by the generator. When the voltage of the inverter charger is higher than the set value, the inverter charger will automatically shut down the generator.

## INFO

- Read the user manual of the AC Input carefully before connection. Make sure the generator can automatically start or stop. Identify NC (normally closed contact), NO (normally open contact), and C (common static contact) of the generator and ensure signal lines are connected properly.

## NOTE

- You can set the voltage of the inverter charger in Program 96. The voltage should be set after the inverter charger is turned on. Finish the installation of the inverter charger first. For more instructions, read [Program Codes](#) in the user manual.
- Do not store the inverter charger with automatic generator start feature enabled. Generators exhaust dangerous fumes in operation.

## WARNING

- Risk of electric shock! Make sure the AC Input is turned off during connection.

## Essential Accessories

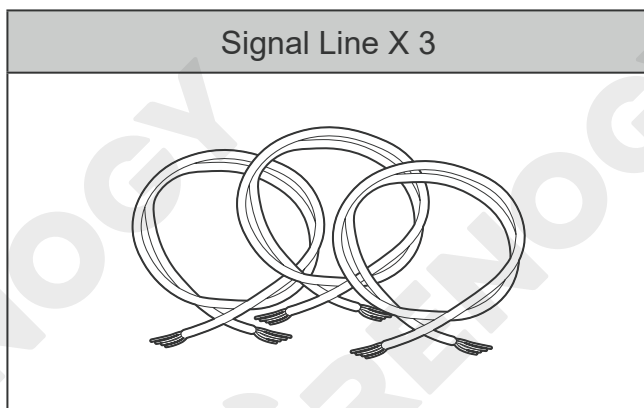

## NOTE

- There is no polarity requirement for the signal line.
- Strip some insulation off the signal line by using a wire stripper according to the depth of the wiring hole.

# Automatic Generator Start

## Wiring Diagram

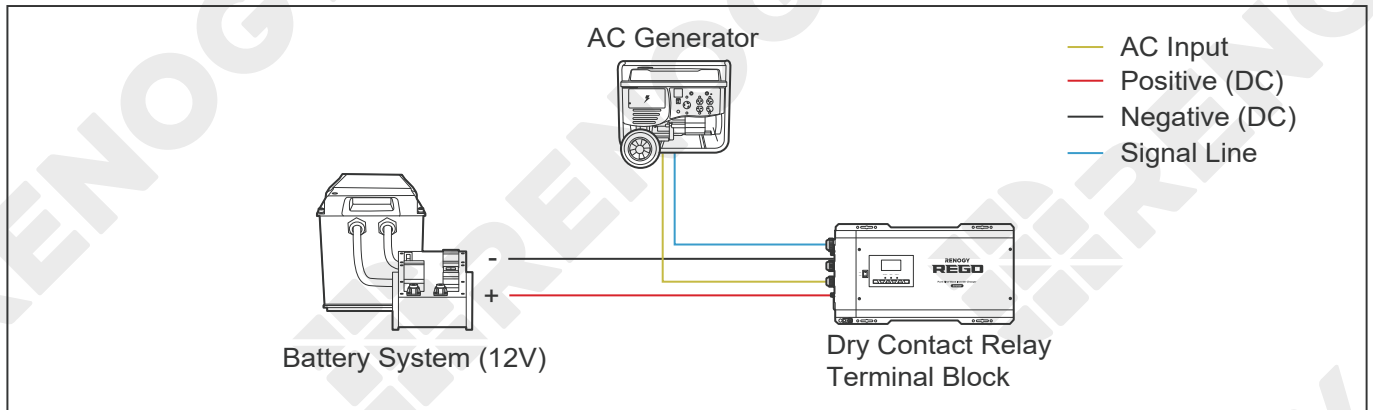

## INFO

- Connect three signal lines to NC (normally closed contact), NO (normally open contact), and C (common static contact) of the AC Input. For more instructions, read the user manual of AC Input.

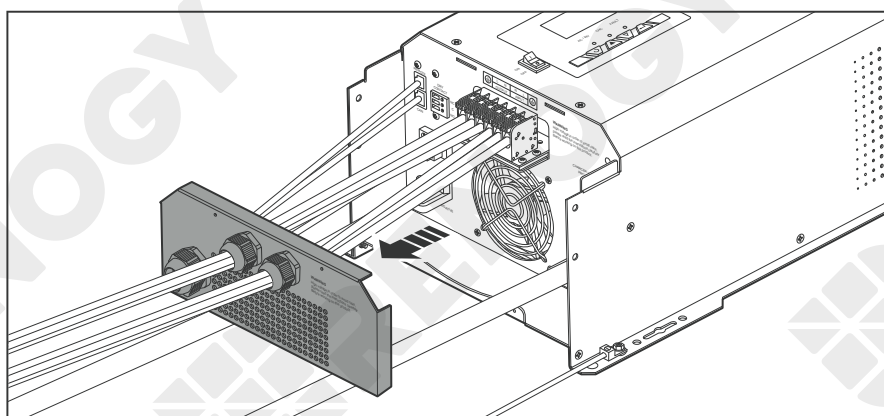
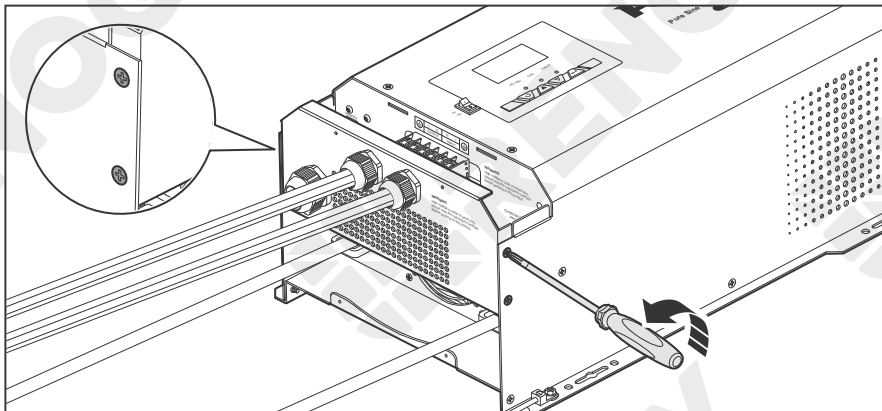

# Automatic Generator Start

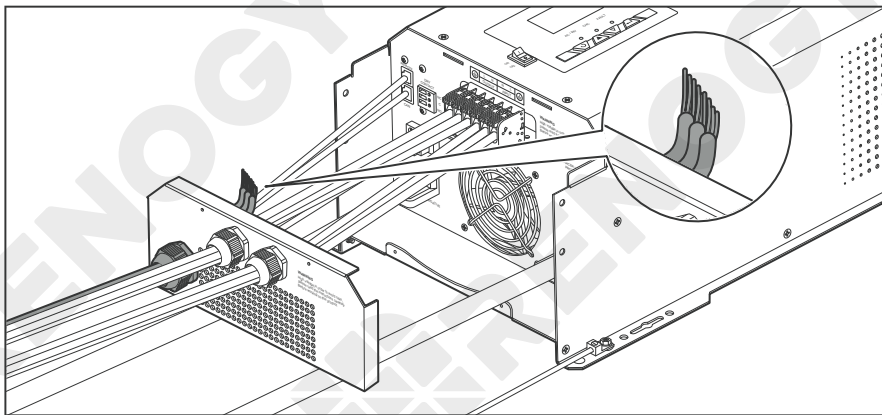

3. Run three signal lines through the Remote & Accessory Cable Entry.

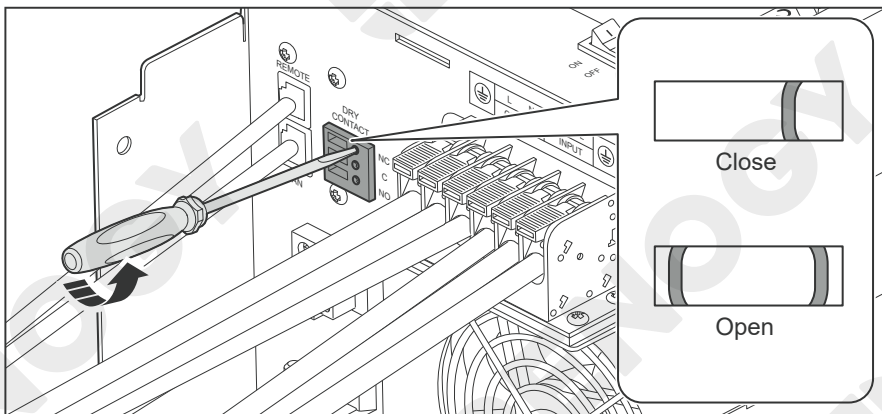

4. Turn the cable retainer screws of NC, C and NO of Dry Contact Relay Terminal Block counterclockwise with a slotted screwdriver to ensure that the cable retainers are open.

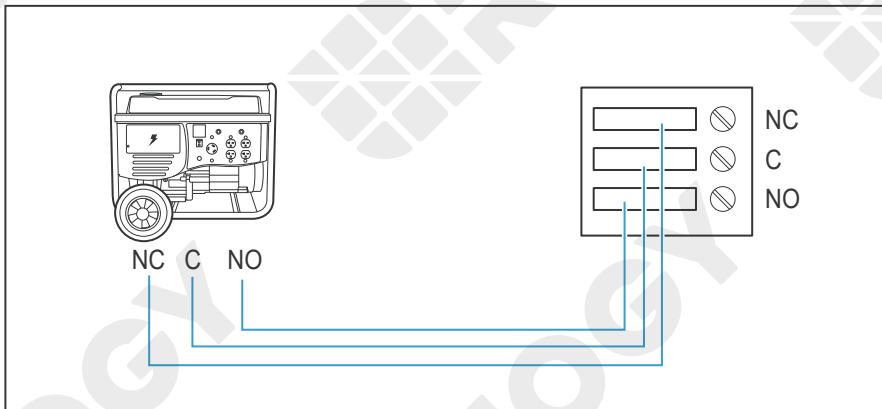

5. Connect three signal lines to the corresponding NC, C, and NO wiring holes.

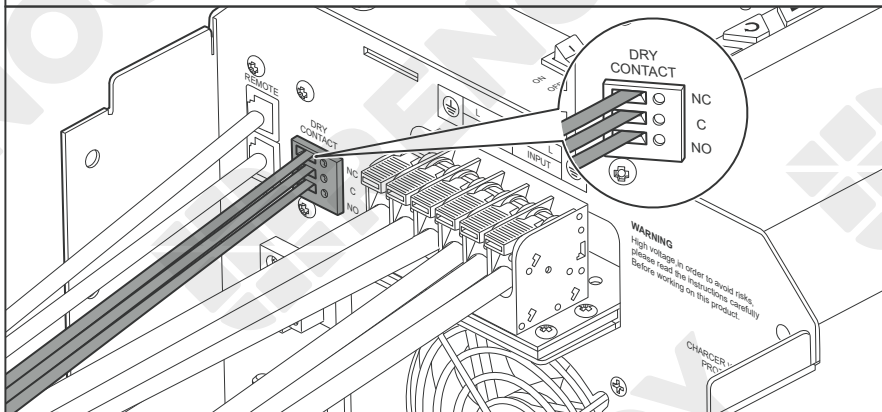

## NOTE

- Some generators only have NC (normally closed contact) and C (common static contact) or NO (normally open contact) and C (common static contact). You can connect them on demand.

# Automatic Generator Start

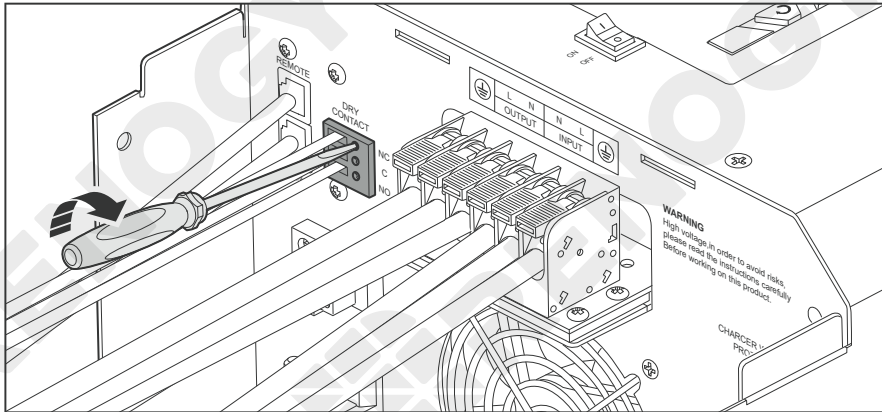

6. Turn the cable retainer screws of NC, C and NO clockwise with a slotted screwdriver to fasten the cable.

## **i** NOTE

- Do not overtighten the cable retainer screws. Otherwise it will lead to stripped screws or screw bending.

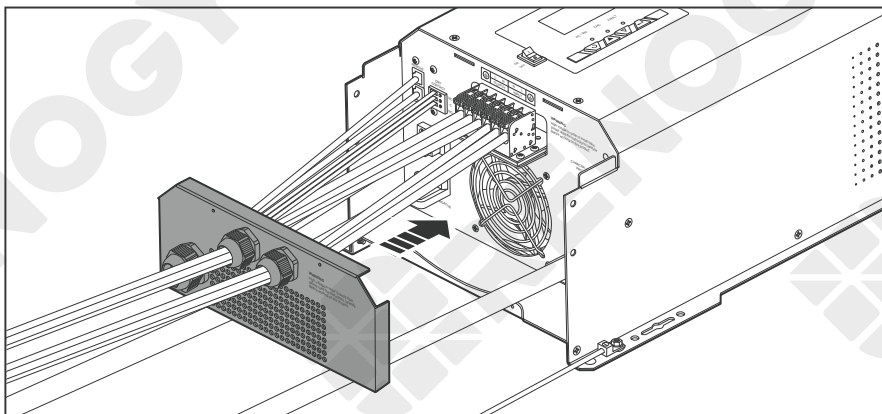

7. Install the AC Cable & Accessory Plate.

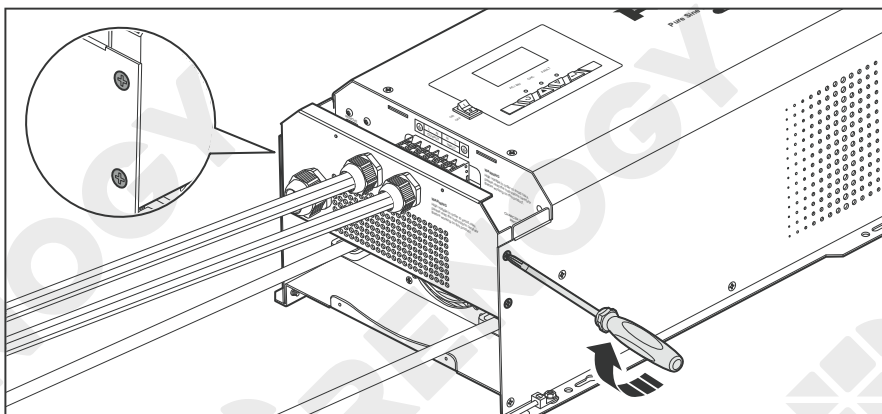

8. Install four retaining nuts of the AC Cable & Accessory Plate by turning them counterclockwise with a Phillips screwdriver.

If your inverter charger uses the DC Generator as the power supply and the DC Generator can automatically start or stop, you can connect the DC Generator to the inverter charger via the signal line. The inverter charger will automatically start and stop the generator according to the voltage you set. The signal line is connected in the same way as the AC Input.

## **i** NOTE

- Make sure that the DC Generator is properly connected to the inverter charger.

# Communication

The communication connection is optional. The REGO Inverter Charger can communicate with other REGO devices and monitoring devices, enabling safe operation, smart control, remote monitoring, and programmable settings.

## WARNING

- Risk of electric shock! Turn off the inverter charger and the power supply devices connected to the inverter charger before connection.
- Wear proper protective equipment and use insulated tools during operation. Be careful when touching bare terminals of capacitors as they may retain high lethal voltages even after the power is removed.

## Inter-Device Communication

Depending on the installation condition, the RV-C communication connections between the inverter charger and other REGO devices can be established with backbone or daisy chain topology. The inter-device communication allows the inverter charger to dynamically adjust the charging profile for an optimal and safe charge.

### Backbone Topology

The backbone topology applies to RVs that are integrated with RV-C buses with built-in 120Ω resistors on both ends. Check the RV user manual for details or contact the RV manufacturer if necessary.

For technical support from Renogy, please contact us through [renogy.com/contact-us/](https://renogy.com/contact-us/).

## CAUTION

- Connect devices to the inverter charger according to the wiring diagram provided by the RV manufacturer.

Choose proper communication cables according to your specific demands.

### Recommended Accessories

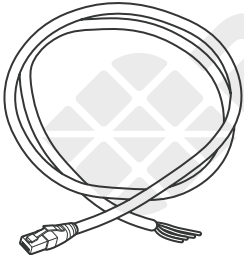
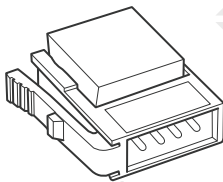
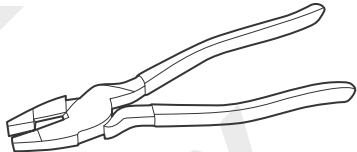
LP16 Plug (7-Pin) to Bare Drop Cables	Drop Plugs	Split Joint Pliers
		

# Communication

## **i** NOTE

- The drop cable shall not exceed 19.6 feet (6 m), and the RV-C bus shall not exceed 98.4 feet (30 m).
- Different drop sockets are used on the RV-C bus by different RV manufacturers. Select the Drop Plugs that match the drop sockets for the inter-device communication connections. If you are not sure about the Drop Plug selection, check with the RV manufacturer. This user manual takes the Mini-Clamp II plug (4-Pin) as an example.
- Different Drop Plugs follow different pinouts. Crimp the Drop Plugs on the Drop Cables following the correct pinout. If you are not sure about the Drop Plug pinout, check with the RV manufacturer. This user manual takes the pinout of the Mini-Clamp II plug (4-Pin) as an example.

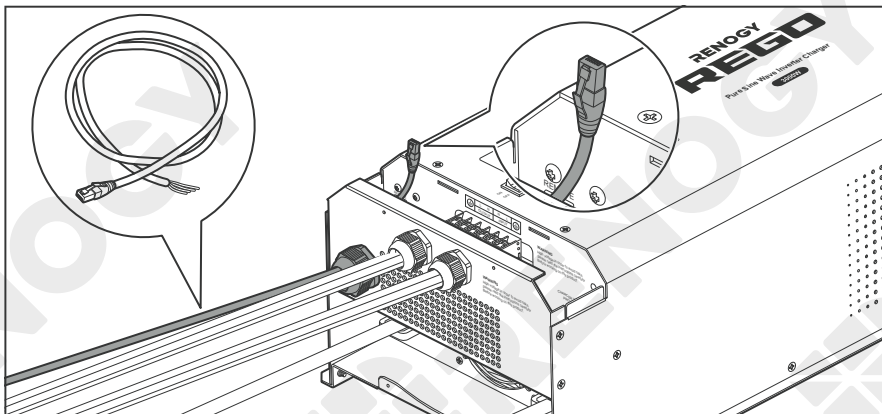

1. Insert the RJ45 connector of RJ45 Plug to the Bare Drop Cable through the Remote & Accessory Cable Entry.

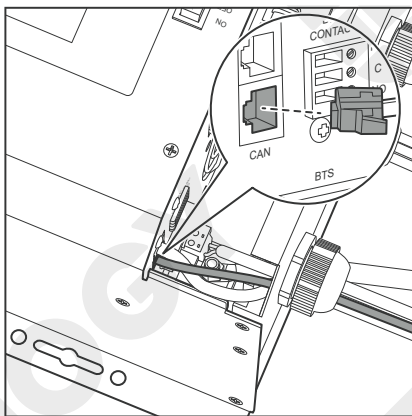

2. Connect the RJ45 connector to the Communication Port (CAN Bus).

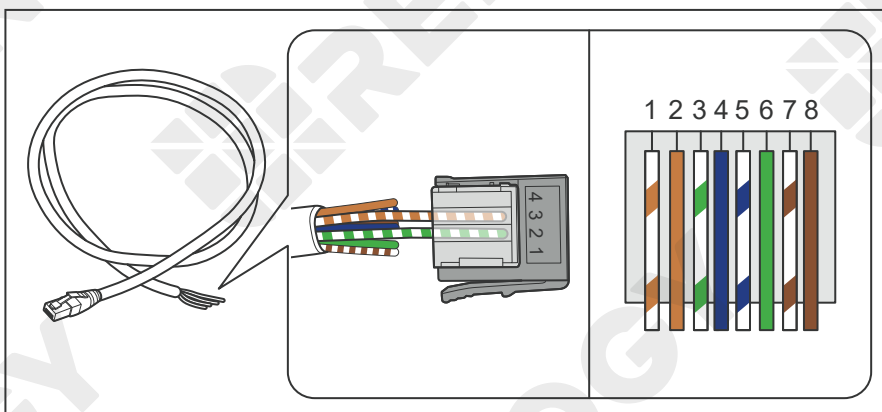

3. The white green CAN\_H wire goes to pin 2 and the white orange CAN\_L wire goes to pin 3. Leave pin 1 and pin 4 empty.

# Communication

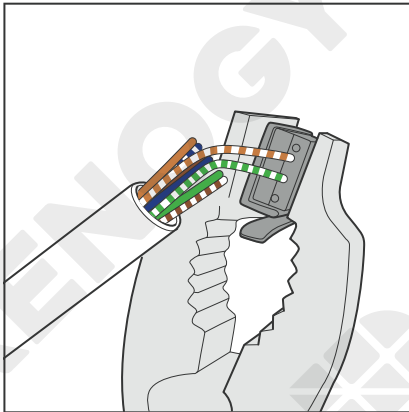

4. Squeeze the crimp areas of the Drop Plugs with the Split Joint Pliers.

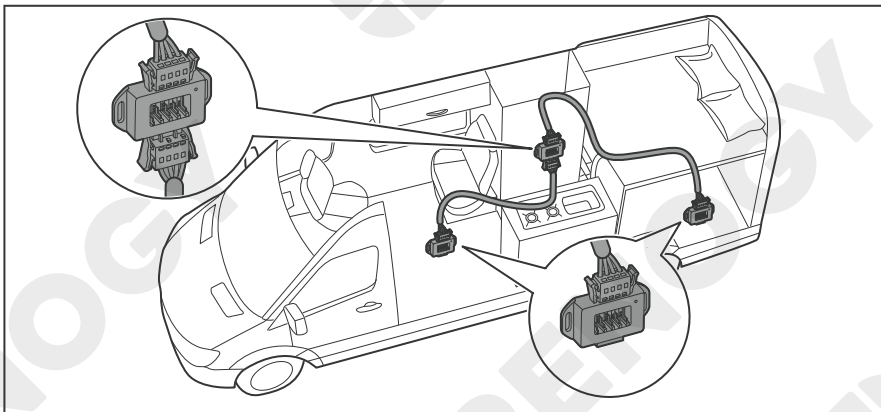

5. Locate the drop tap (not included) on the RV-C bus that is the closest to the installation site of the inverter charger. The drop taps are usually located above the entry door, in the bathroom, or under the bed in the RV.

## **i** NOTE

- If you fail to locate the drop taps, please contact the RV manufacturer for help.

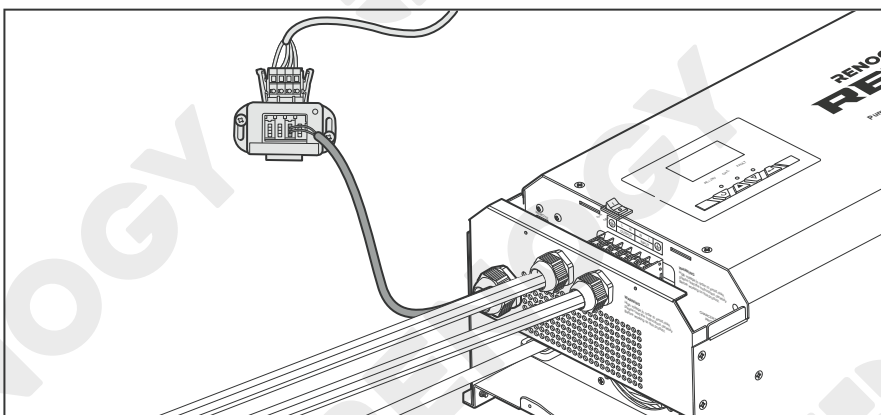

6. Connect the Drop Plugs on the drop cables and other REGO devices to the drop sockets on the drop tap.

## **i** NOTE

- Different drop taps are used on the RV-C bus by different RV manufacturers. This user manual takes the 4-socket drop tap as an example.

# Communication

## Daisy Chain Topology

The daisy chain topology applies to RVs that are not integrated with RV-C buses.

### **i** NOTE

- Do not place the inverter charger at the first or last of the daisy chain network.

### Recommended Accessories

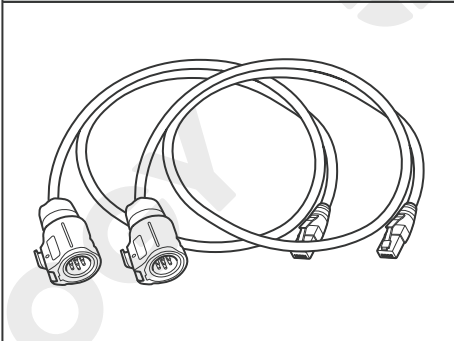
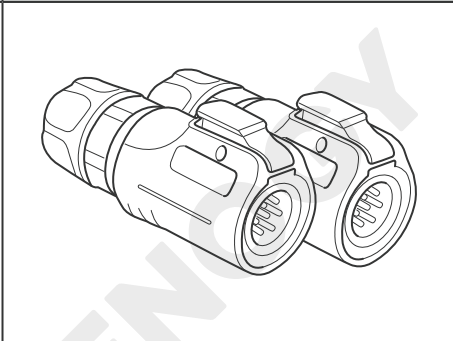
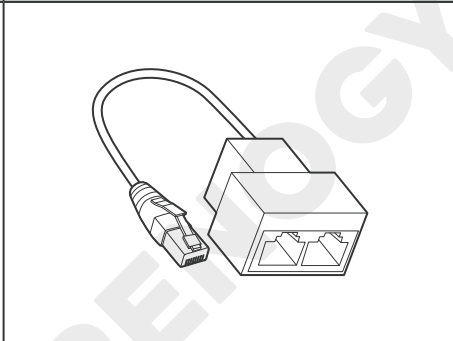
LP16 Plug (7-Pin) to RJ45 Communication Adapter Cable	LP16 Terminator Plug (7-Pin)	RJ45 Network 1 to 2 Port Ethernet Adapter Splitter
		

### **i** NOTE

- Select the appropriate communication cable (sold separately) according to the distance between devices. The communication cable should be less than 19.6 feet (6 m).

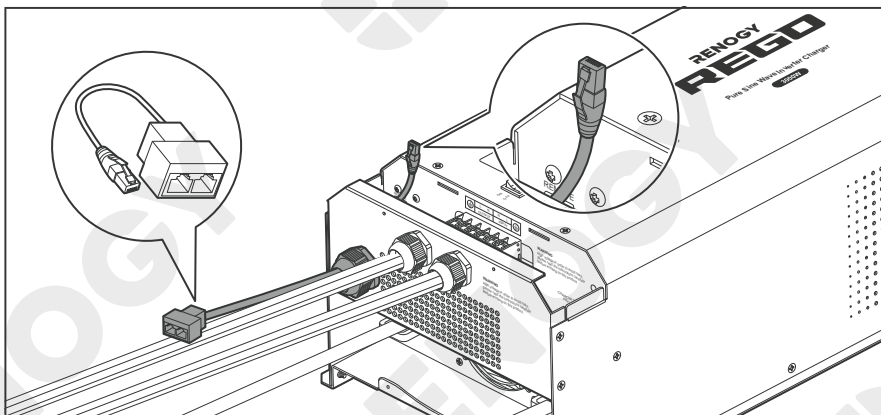

1. Insert the RJ45 connector of RJ45 Network 1 to 2 Port Ethernet Adapter Splitter through the Remote & Accessory Cable Entry.

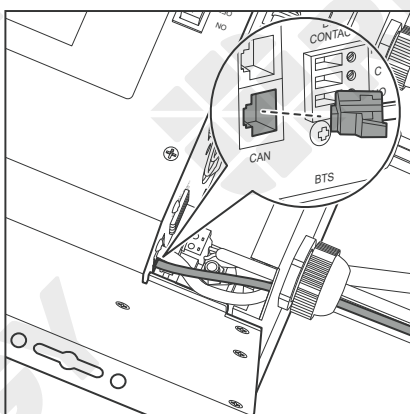

2. Connect the RJ45 connector to the Communication Port (CAN Bus).

# Communication

Inter-Device Communication

Monitoring Device Communication

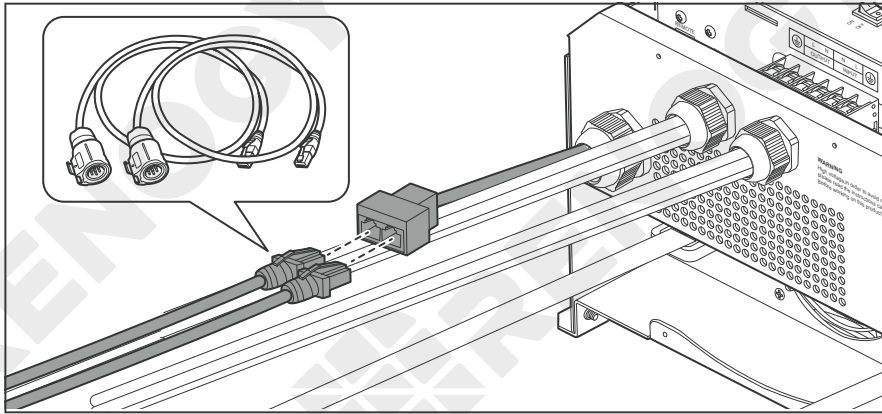

3. Connect the two RJ45 connectors of LP16 Plug (7-Pin) to the RJ45 Communication Adapter Cables to the RJ45 Network 1 to 2 Port Ethernet Adapter Splitter.

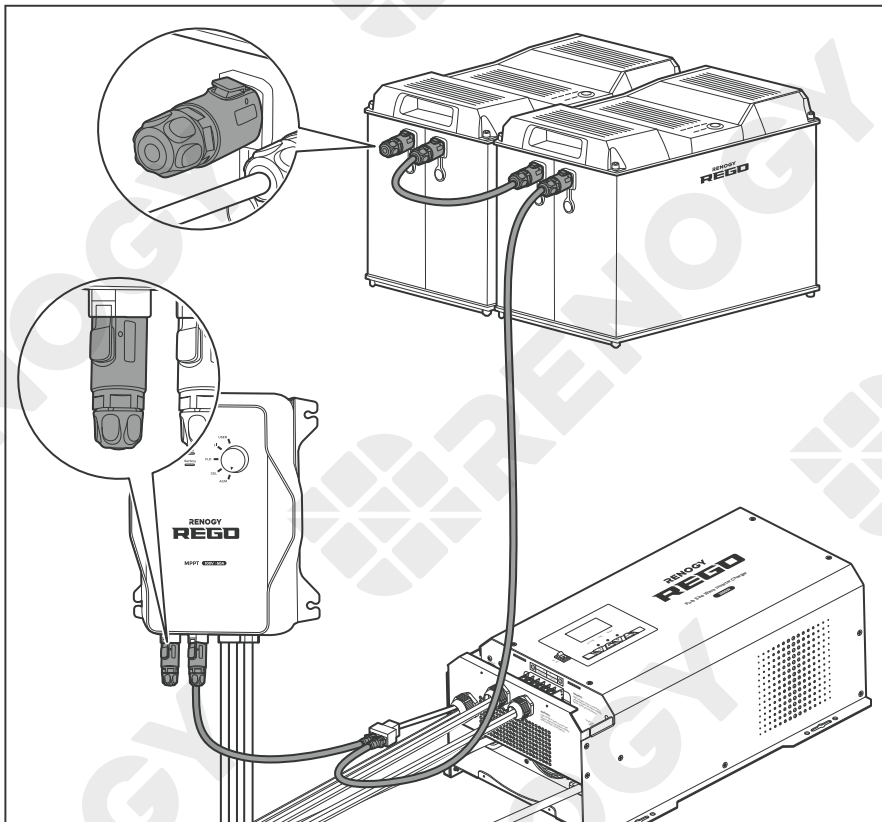

4. Connect the other ends of the LP16 Plug (7-Pin) to RJ45 Communication Adapter Cables to the vacant CAN communication ports of other REGO devices. Insert the terminal plugs (sold separately) into the vacant CAN communication port of the first and last REGO devices.

## Monitoring Device Communication

Depending on the application, the short-range or long-range communication connections can be established between the inverter charger and monitoring devices. The monitoring device allows for the monitoring and programming of the inverter charger or even the complete system.

### **i** NOTE

- Make sure the Bluetooth of your phone is turned on.
- Scan the QR code on the last page of the user manual to download the DC Home app.
- The version of the DC Home app might have been updated. Illustrations in the user manual are for reference only. Follow the instructions based on the current app version.
- Make sure that the inverter charger is properly installed and powered on before it is paired with the DC Home app.

### Short-Range Monitoring

If only short-range monitoring is required, connect the inverter charger to the DC Home app directly through the Bluetooth of your phone.

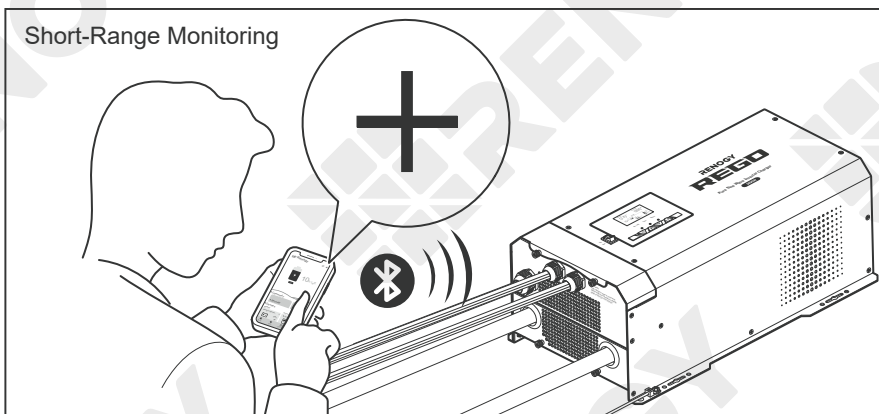

1. Open the DC Home app. Tap **+** to search for new devices.

### **i** NOTE

- Keep the phone within 10 feet (3 m) of the inverter charger.

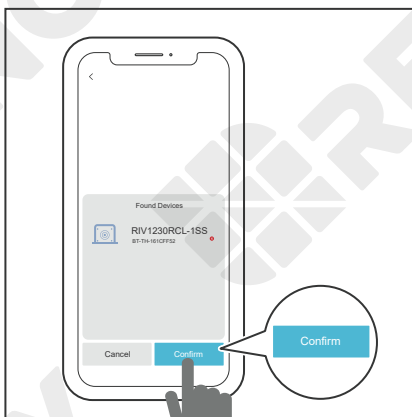

2. Tap **Confirm** to add the newly found device to the device list.

# Communication

Inter-Device Communication

Monitoring Device Communication

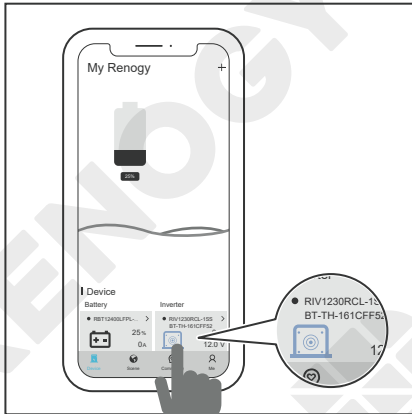

3. Tap the inverter icon to enter the device information interface.

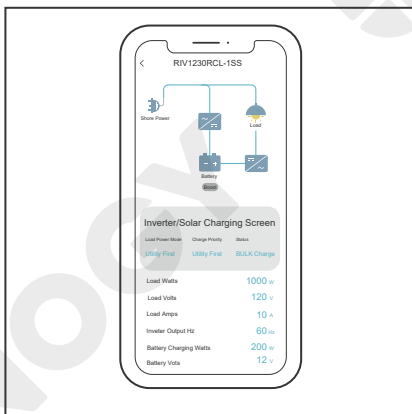

4. Check the operation status of the inverter charger in this interface.

## Long-Range Monitoring

If long-range communication and programming are required, connect the inverter charger to Renogy ONE through Bluetooth or wires, and the Renogy ONE to the DC Home app through Wi-Fi.

## Recommended Accessories

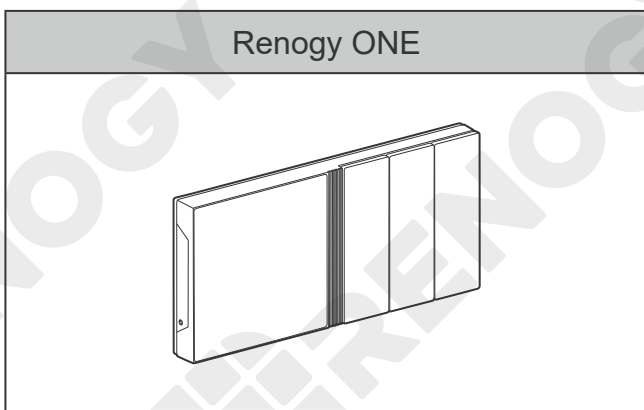

### NOTE

- Make sure that the Renogy ONE is powered on before the connection.

### INFO

- Read the user manual of Renogy ONE at [renogy.com](http://renogy.com) before the connection.

# Communication

Inter-Device Communication

Monitoring Device Communication

## ■ Wireless connection

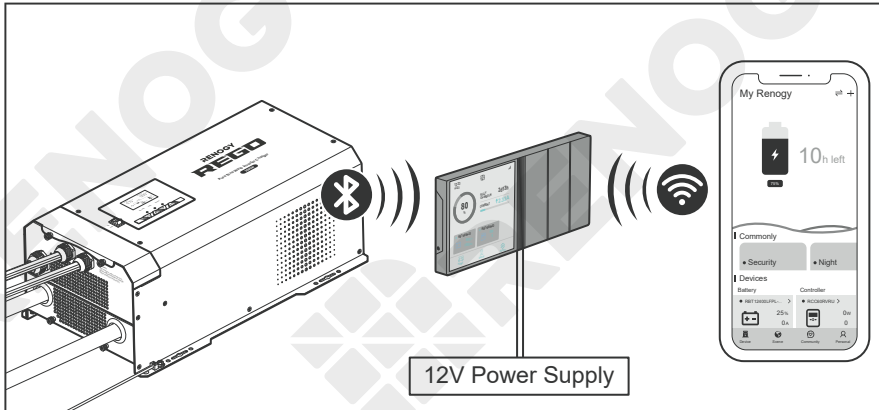

Connect the inverter charger to the Renogy ONE (sold separately) through the Bluetooth of your phone, and pair the Renogy ONE with the DC Home app through Wi-Fi. Monitor the inverter charger on the Renogy ONE or the DC Home app.

## **i** NOTE

- Make sure the inverter charger does not communicate with any other device.
- Keep the phone within 10 feet (3 m) of the inverter charger.

## ■ Wired connection

### Recommended Accessories (Backbone Topology)

RJ45 Plug to Bare Drop Cable	Common Drop Tap

## **i** NOTE

- Select the appropriate communication cable (sold separately) according to the distance between devices. The communication cable should be less than 19.6 feet (6 m).

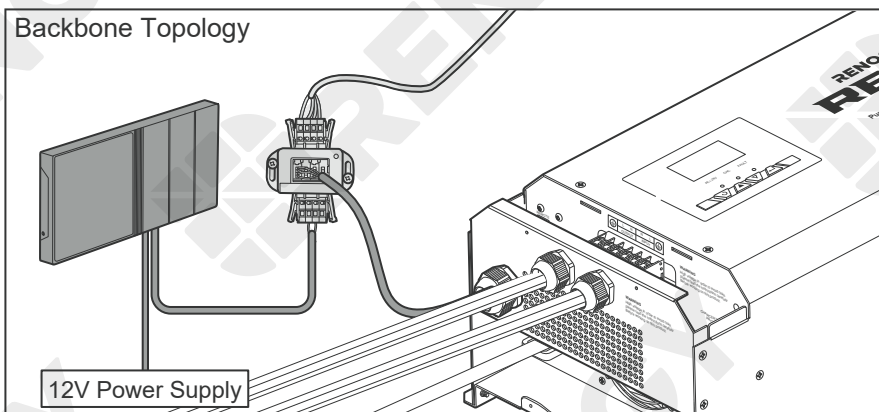

1. Replace the terminated drop tap at either end of the RV-C bus with the Common Drop Tap (not included). Secure the bare wires of the Drop Cable (not included) onto the terminal block plug of the Common Drop Tap following the terminal block plug pinout. Plug the Drop Cable to the RJ45 port of Renogy ONE.

# Communication

## **i** NOTE

- Different terminal block plugs are used on different Common Drop Taps and follow different pinouts. If you are unsure about the pinout of the terminal block plug, contact the RV manufacturer.
- Refer to [Backbone Topology](#) for more instructions.

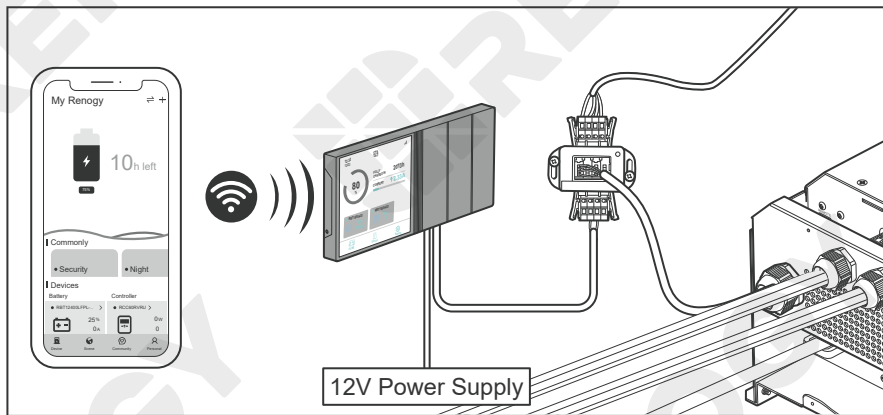

2. Monitor and program the complete system on Renogy ONE or the DC Home app.

## **i** NOTE

- Keep the phone within 10 feet (3 m) of the inverter charger.

### Recommended Accessories (Daisy Chain Topology)

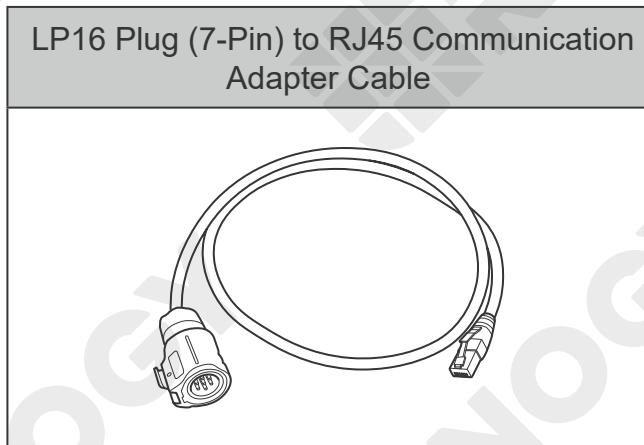

## **i** NOTE

- Select the appropriate communication cable (sold separately) according to the distance between devices. The communication cable should be less than 19.6 feet (6 m).

# Communication

Inter-Device Communication

Monitoring Device Communication

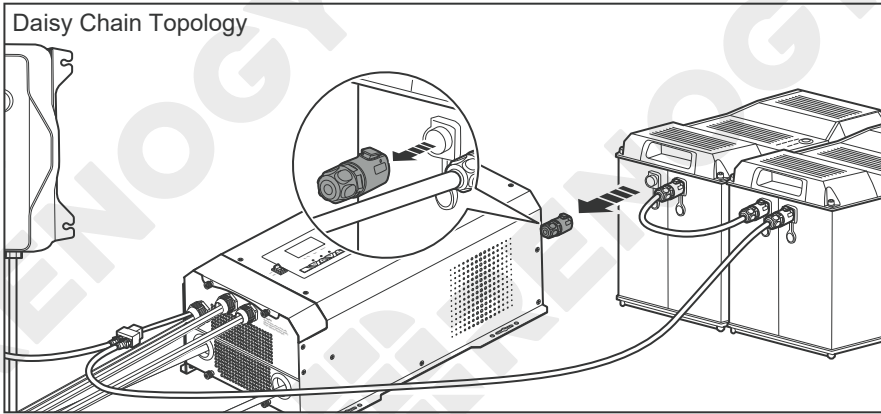

1. Remove the Terminator Plug from the REGO device at either end of the daisy chain.

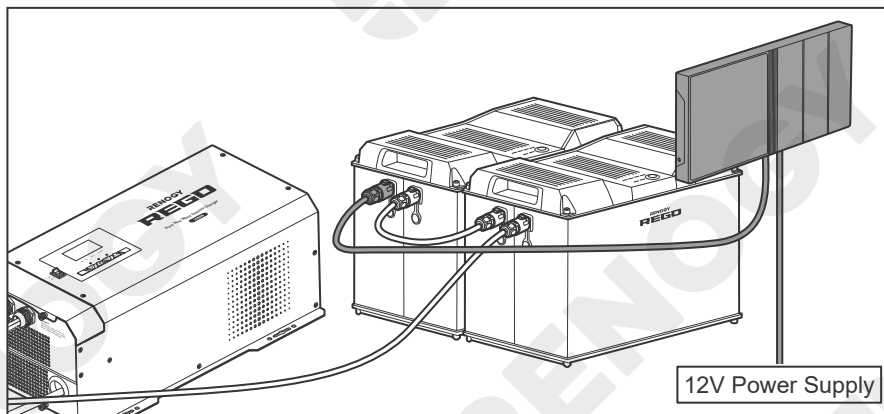

2. Connect the Renogy ONE to the free CAN Communication Port on the REGO device with the Communication Adapter Cable (sold separately).



3. Pair Renogy ONE with the DC Home app. Monitor and program the complete system on the Renogy ONE or the DC Home app.

## NOTE

- Keep the phone within 10 feet (3 m) of the inverter charger.

# Putting Plates Back

Inter-Device Communication

Monitoring Device Communication

Reinstall the plates into the inverter charger after wiring.

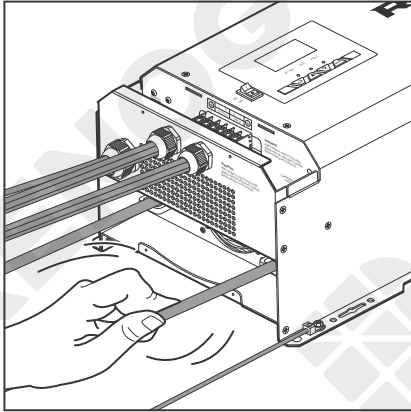

1. Check and make sure all cable connections are tight and secure.

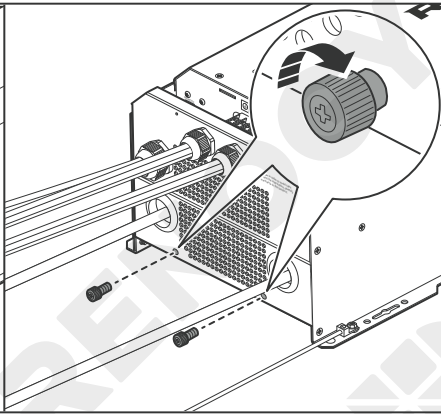
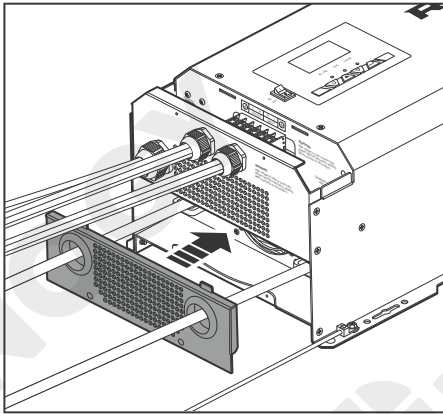

2. Install the DC Cable Plate and drive the two panel screws clockwise to fix the plate.

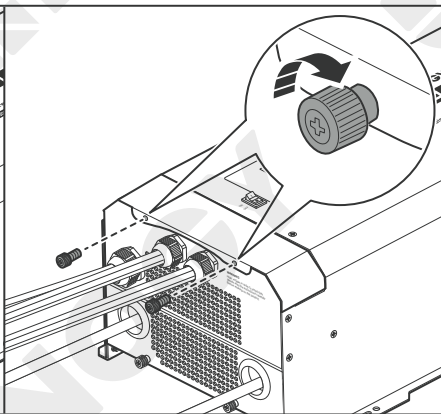
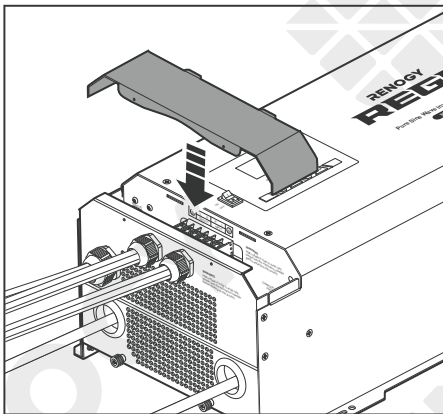

3. Install the Top Plate. Drive the two panel screws clockwise to fix the plate.

# Power on

Main Switch

Wired Remote Control

After installation, power on the battery and the AC input connected to the inverter charger, then turn on the inverter charger. REGO 12V 3000W Inverter Charger can be powered on via the main switch or wired remote control.

## **i** NOTE

- Before the inverter charger is powered on, ensure that the load is turned off. Otherwise the inverter charger may be overloaded.
- After the inverter charger is turned on, it will enter the self-test mode. The buzzer will sound for 7 seconds and the fan will turn automatically at the same time. The self-test takes about one minute. After the self-test, the sound disappears, and the fan stops running.

## Main Switch

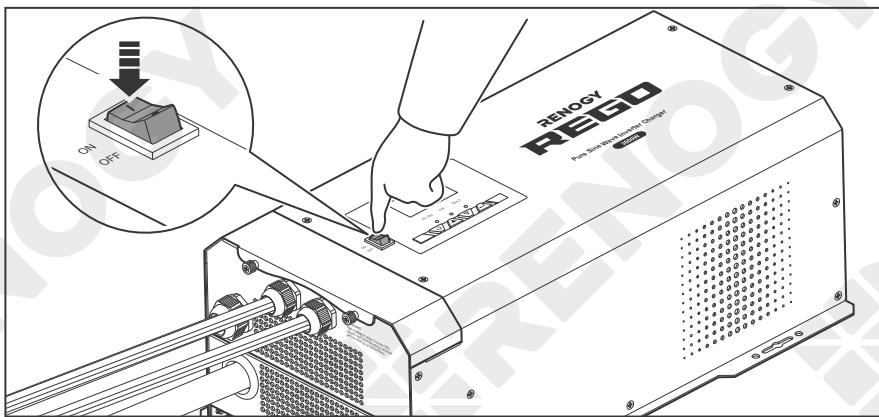

1. Press the main switch of the inverter charger to the "ON" position to power the inverter charger on.

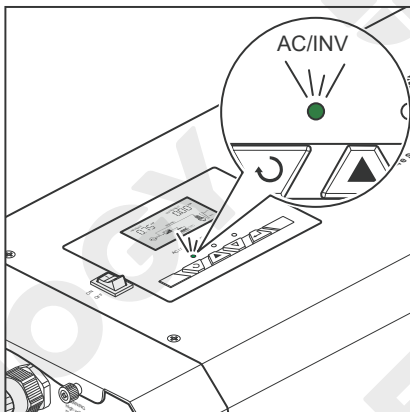

2. The screen lights up and displays the status after the inverter charger is powered on. The AC/INV indicator will light up based on the usage.

After the inverter charger is properly installed and powered on, the inverter charger works normally when all of the following conditions are met:

- The buzzer rings for 7 seconds
- The fan operates with the sound
- The screen lights up
- The indicator lights up

Please contact us through [renogy.com/contact-us/](https://renogy.com/contact-us/).

# Power on

Main Switch

Wired Remote Control

## Wired Remote Control

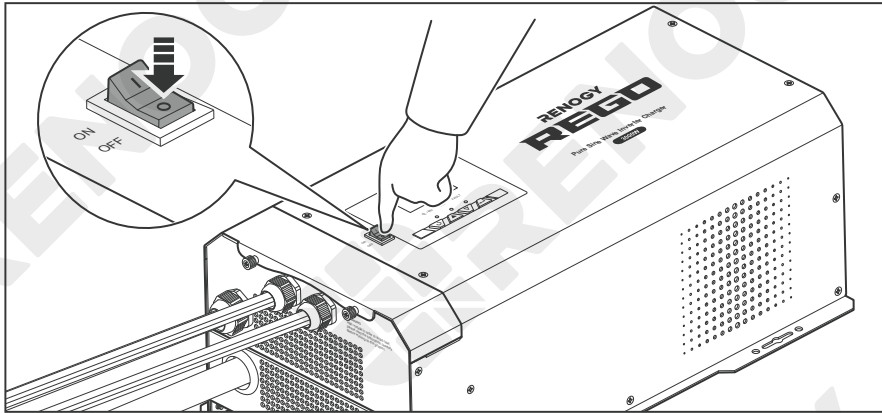

1. If you use the wired remote control, please turn the main switch of the inverter charger to "OFF" first.

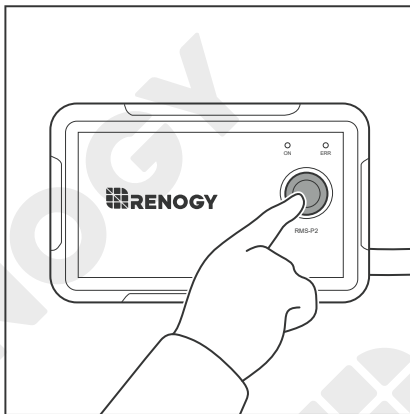

2. Press the button on the wired remote control.

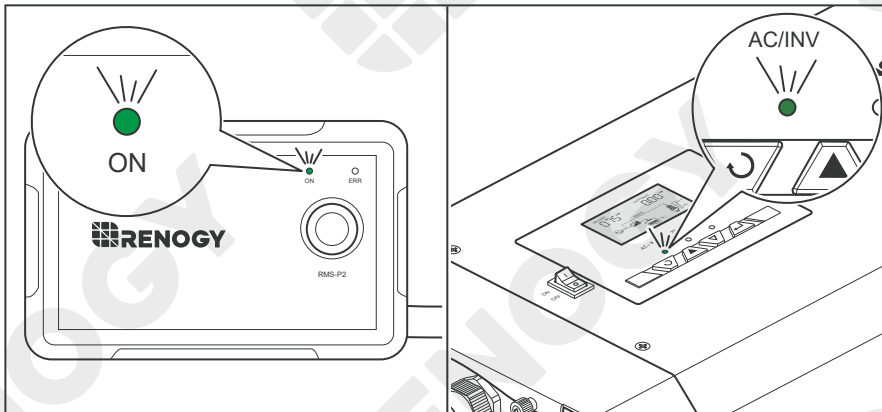

3. After the inverter charger is powered on, the ON indicator of the wired remote control and the AC/INV indicator of the inverter charger will light up based on the usage. The LCD of the inverter charger lights up and displays the operation status.

After the inverter charger is properly installed and powered on, the inverter charger works normally when all of the following conditions are met:

- The buzzer rings for 7 seconds
- The fan operates with the sound
- The screen lights up
- The indicator lights up
- The ON indicator of the wired remote control lights up

Please contact us through [renogy.com/contact-us/](http://renogy.com/contact-us/).

# Operation

LCD Button Setting Battery Type User Mode

## LCD

You can view the current operation status and warning messages of the inverter charger on the LCD.

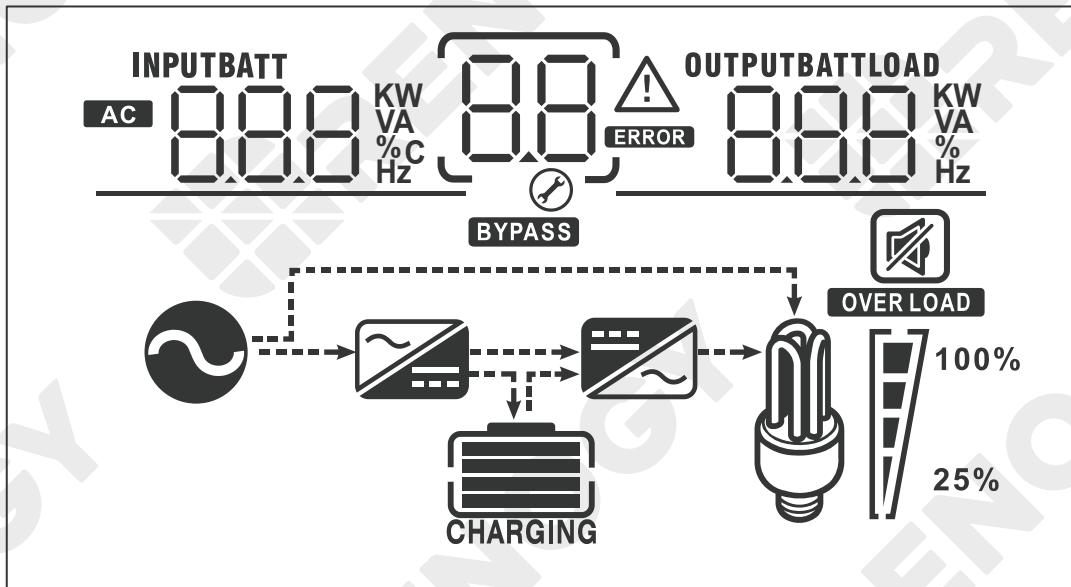

Icon	Function Description
<b>Input Source Information</b>	
	Indicates the AC input.
	Indicates input voltage, input frequency, battery voltage, and charger current.
<b>Configuration Program and Fault Information</b>	
	Indicates setting programs.
	Indicates the warning and fault codes. Warning:  flashing with warning code. Fault:  lighting with fault code.
<b>Output Information</b>	
	Indicates output voltage, output frequency, load percent, load in VA, load in Watt, and discharging current.

# Operation

LCD

Button

Setting Battery Type









User Mode

Icon	Function Description
<b>Battery Information</b>	
	Indicates battery level by 0-24%, 25-49%, 50-74%, and 75-100% in battery mode and charging status in line mode.

In AC mode, the LCD displays the battery charging status.

Status	Battery voltage	LCD Display
Constant Current mode / Constant Voltage mode	< 12.0V	Four bars will flash in turn.
	12.0V - 12.5V	Bottom bar will be on and the other three bars will flash in turn.
	12.5V - 13.0V	Bottom two bars will be on and the other two bars will flash in turn.
	> 13.0V	Bottom three bars will be on and the top bar will flash.
Floating mode. Batteries are fully charged.		Four bars will be on.

In battery mode, the LCD displays the battery capacity.

Load Percentage	Battery Voltage	LCD Display
Load > 50%	< 10.3V	
	10.3V - 10.8V	
	10.8V - 11.3V	
	> 11.3V	
20% < Load < 50%	< 10.9V	
	10.9V - 11.4V	
	11.4V - 11.9V	
	> 11.9V	

# Operation

LCD

Button

Setting Battery Type

User Mode

Icon		Function Description			
	<b>Load Percentage</b>	<b>Battery Voltage</b>		<b>LCD Display</b>	
	Load < 20%	< 11.2V			
		11.2V - 11.7V			
		11.7V - 12.2V			
		> 12.2V			
<b>Load Information</b>					
<b>OVER LOAD</b>		Indicates overload.			
 100% 25%	Indicates the load level by 0-24%, 25-49%, 50-74%, and 75-100%.				
	0-24%	25-49%	50-74%	75-100%	
<b>Mode Operation Information</b>					
		Indicates the inverter charger is connected to the shore power.			
<b>BYPASS</b>		Indicates the load is supplied by the utility power.			
		Indicates the utility charger circuit is working.			
		Indicates the DC / AC inverter circuit is working.			
<hr/>					
		Indicates the alarm of the inverter charger is disabled.			

# Operation

LCD

Button

Setting Battery Type

User Mode



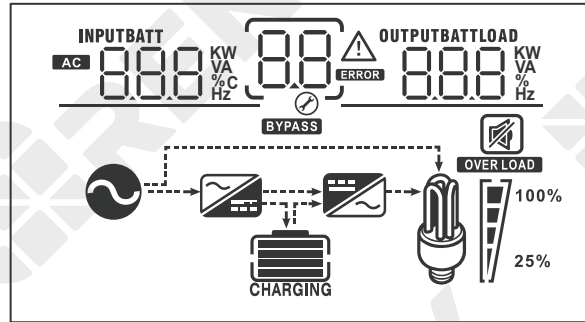

## Button

You can turn to the display pages or set parameters of the inverter charger with the four buttons.

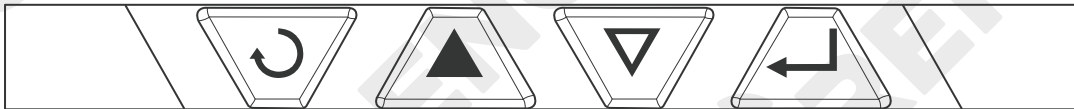

AC/INV      CHG      FAULT



	Exit the settings and go back to the menu.
	Menu key.
	Menu key.
	<ol style="list-style-type: none"> <li>1. Long press the button to enter the parameter setting menu.</li> <li>2. Short press to change / confirm setting in the parameter setting menu.</li> </ol>

# Operation

LCD Button

Setting Battery Type

User Mode

## Setting Battery Type

Set the battery type immediately after the inverter charger is powered on. Refer to the specifications provided by the battery manufacturer when choosing a preset battery. Damage caused by incorrect battery type voids warranty.

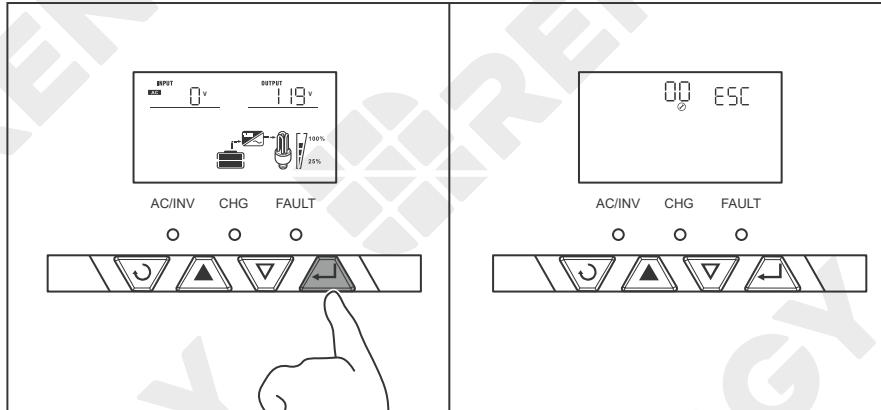

1. Long press  until the LCD enters setting mode.

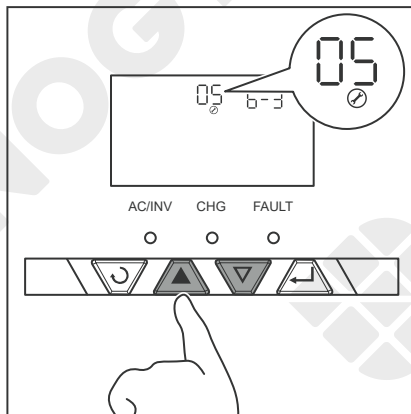

2. Press  or  to display Program 05.

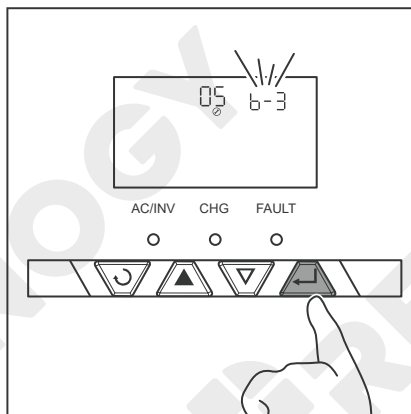

3. Press  to enter 05 settings.

# Operation

LCD Button

Setting Battery Type

User Mode

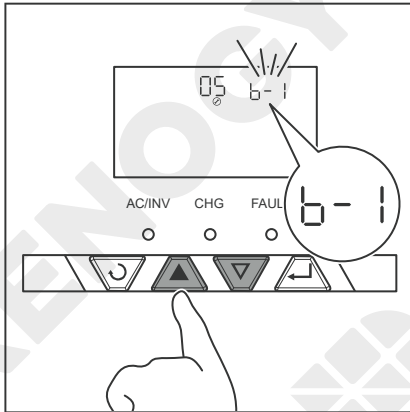

- Press ▲ or ▼ and select a battery type on demand in accordance to the following table.

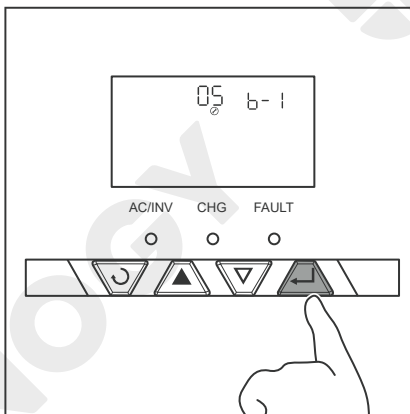

- After selection, press ← to save settings.

Program Code	Description	Parameter Setting	Boost Voltage	Float Voltage
05	For accurate charging, connection to a temperature sensor is required.	Type of battery		
		User Mode 05 b-0	—	—
		Gel 1 05 b-1	14.0V	13.7V
		A.G.M.1 05 b-2	14.1V	13.4V
		A.G.M.2 05 b-3	14.6V	13.7V

# Operation

LCD Button

Setting Battery Type

User Mode

Program Code	Description	Parameter Setting	Boost Voltage	Float Voltage
05 ⌚	For accurate charging, connection to a temperature sensor is required.	Sealed Lead Acid 05 <u>b-4</u> ⌚	14.4V	13.6V
		Gel 2 05 <u>b-5</u> ⌚	14.4V	13.8V
		Open Lead Acid / Flooded 05 <u>b-6</u> ⌚	14.8V	13.8V
		Calcium 05 <u>b-7</u> ⌚	15.1V	13.6V
		De-sulphation 05 <u>b-8</u> ⌚	15.5V for 4 hours	
		LI 05 <u>b-L</u> ⌚	When the voltage reaches 14.7V, the charging will stop. When the voltage drops below 12.9V, the charging will resume.	

## NOTE

- The voltage of lithium charging is preset to 14.7V. When the charging voltage reaches the preset threshold 14.7V, the inverter charger stops charging. It resumes charging when the charging voltage drops below 12.9V.
- If the preset battery parameters are not compatible with your system, you can set the battery type to b-0 to enter the User mode. You can also use the DC Home app to customize the parameters. For details, see [User Mode](#) below.

# Operation

LCD

Button

Setting Battery Type

User Mode

## User Mode

### WARNING

- Read the user manual of the battery when customizing a preset battery. Incorrect battery type selection damages the inverter charger and voids the warranty.

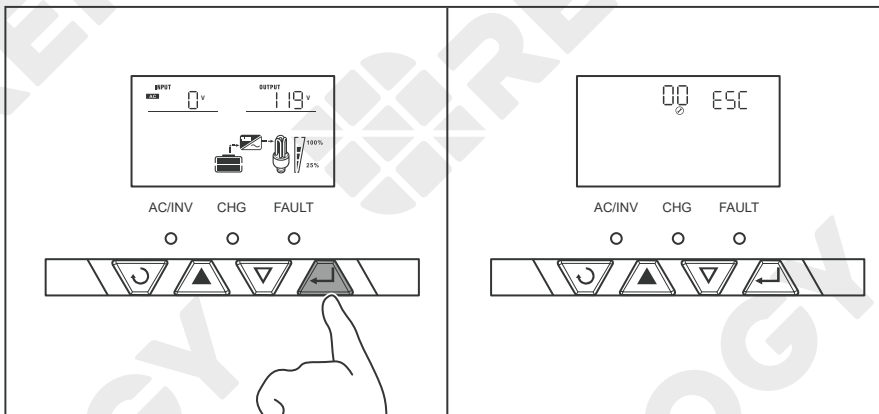

1. Long press  until the LCD enters the setting mode.

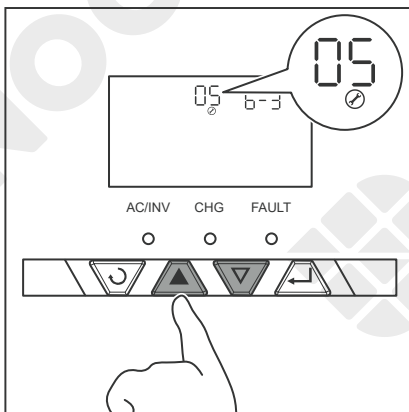

2. Press  or  until the LCD enters Program 05.

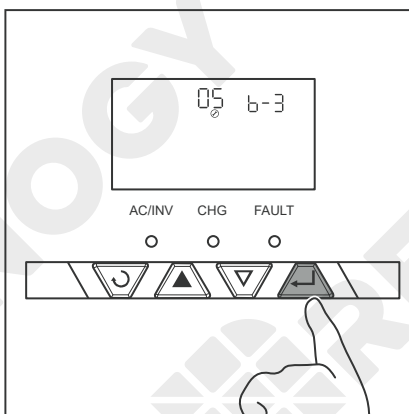

3. Press  to enter 05 settings.

# Operation

LCD Button Setting Battery Type

User Mode

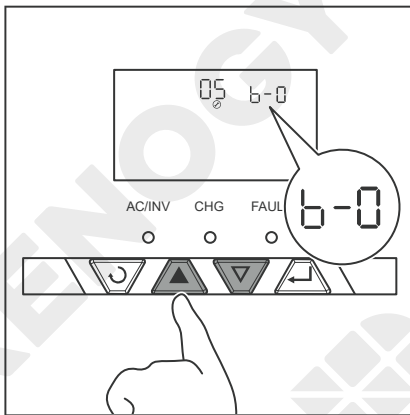

4. Press ▲ or ▼ to select b-0.

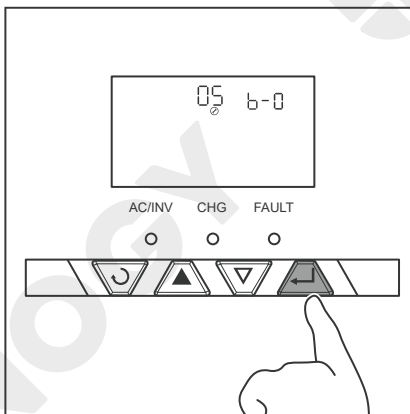

5. After selection, press ↵ to save settings.

By default, this inverter charger is preset to Boost at 14.3V and Float at 13.7V.

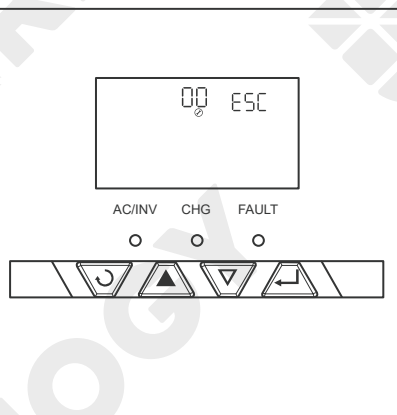
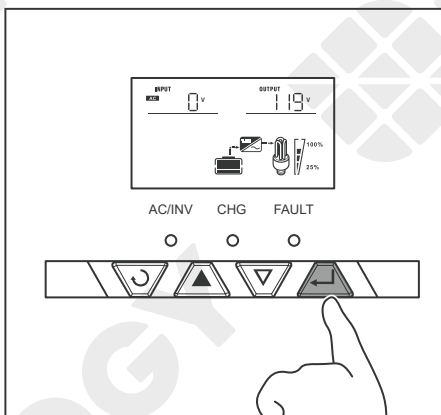

6. Long press ↵ until the LCD enters the setting mode.

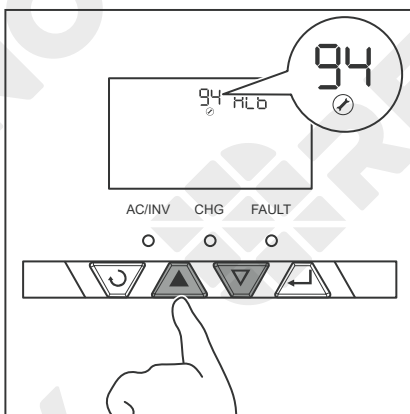

7. Press ▲ or ▼ to enter Program 94.

You can set the battery type in the user mode in Program 94.

# Operation

LCD

Button

Setting Battery Type

User Mode

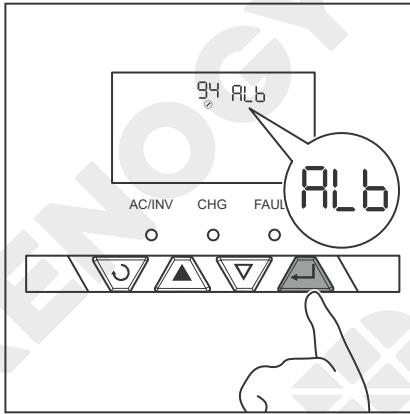

8. Press  $\rightarrow$  to enter 94 settings.

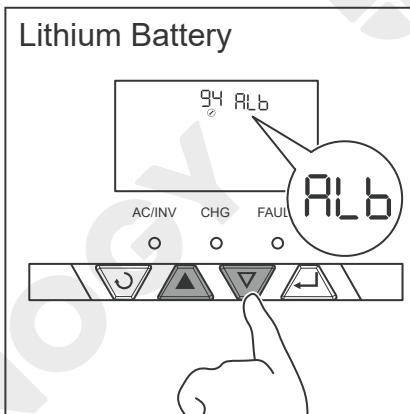

Lithium Battery

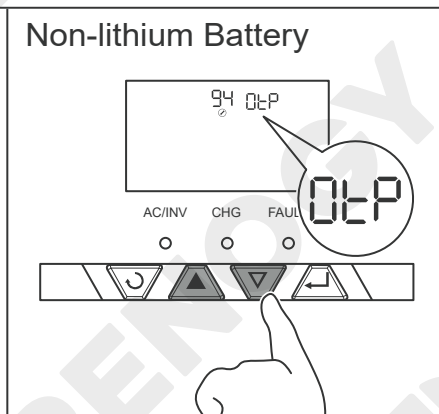

Non-lithium Battery

9. Press  $\uparrow$  or  $\downarrow$  to select ALb or OLP according to the battery type.

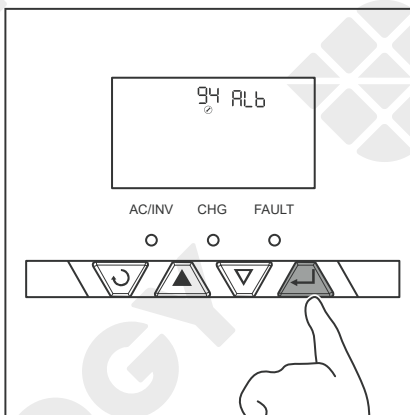

10. After selection, Press  $\rightarrow$  to save settings.

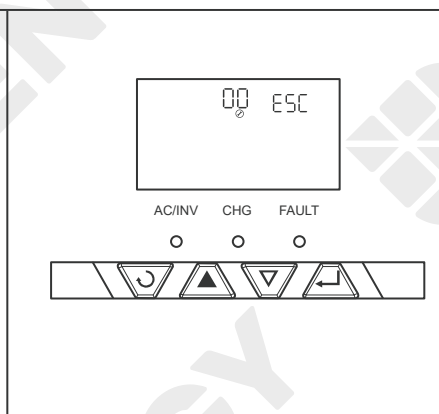
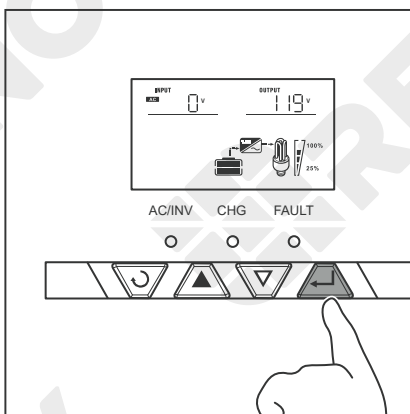

11. Long press  $\rightarrow$  until the LCD enters the setting mode.

# Operation

LCD Button Setting Battery Type

User Mode

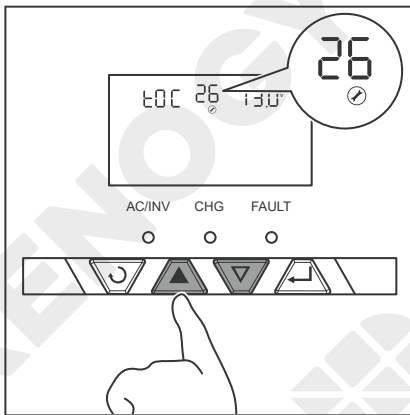

12. Press ▲ or ▼ to enter Program 26.

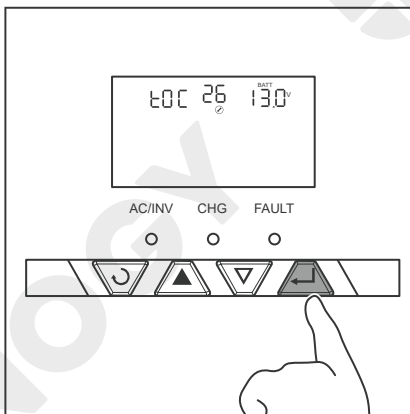

13. Press ↵ to enter 26 settings.

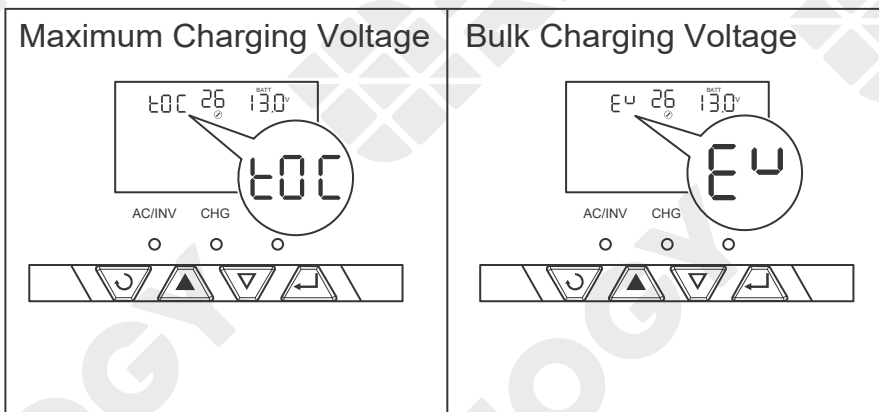

14. For lithium battery, set the maximum charging voltage in Program 26.

For non-lithium battery, set the bulk charging voltage (C.V voltage) in Program 26.

When the battery voltage reaches the preset value, the inverter charger will stop charging the battery.

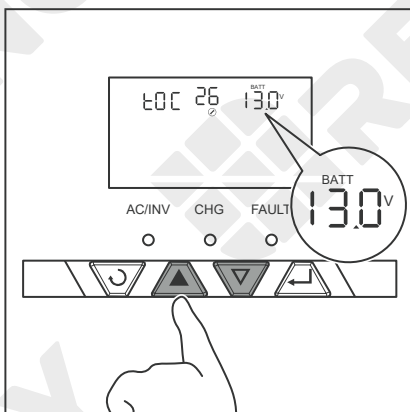

15. Press ▲ or ▼ to set the voltage.

For lithium battery, set the voltage from 13.0V to 15.5V. For non-lithium battery, set the voltage from 13.0V to 15.0V.

# Operation

LCD Button Setting Battery Type

User Mode

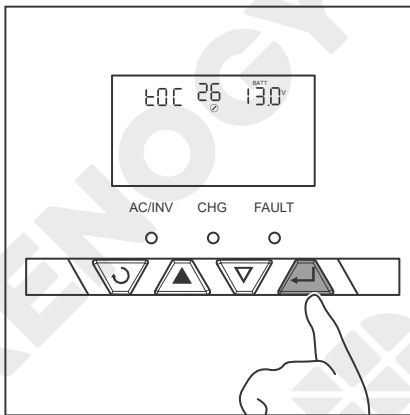

16. After selection, press  $\rightarrow$  to save settings.

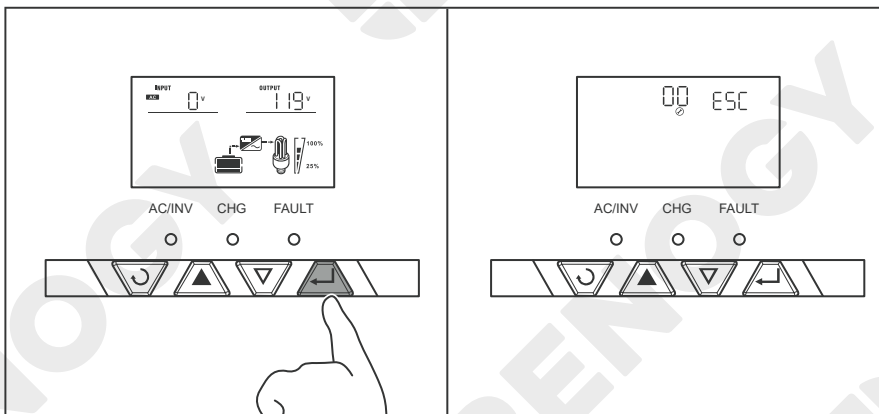

17. Long press  $\rightarrow$  until the LCD enters the setting mode.

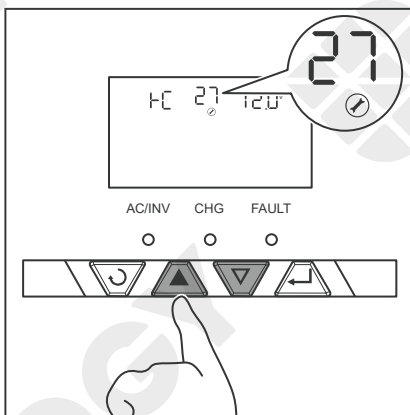

18. Press  $\uparrow$  or  $\downarrow$  to enter Program 27.

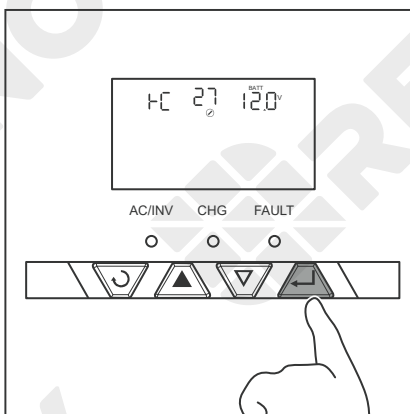

19. Press  $\rightarrow$  to enter 27 settings.

# Operation

## Battery Low Voltage Open Charging

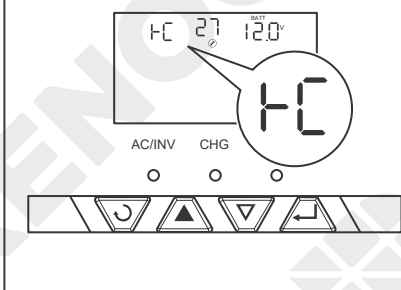

## Floating Charging Voltage

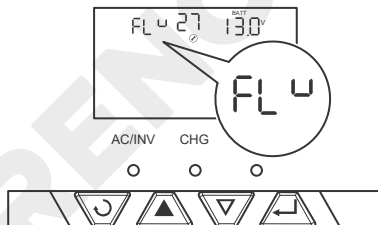

20. For lithium battery, set the battery low voltage open charging in Program 27.

For non-lithium battery, set the floating charging voltage in Program 27.

When the battery voltage is lower than the preset value, the inverter charger starts to charge the battery until the battery voltage reaches the preset value of Program 26.

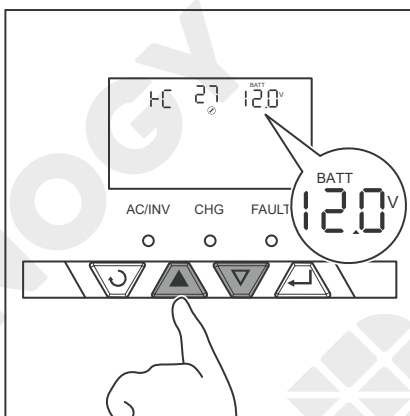

21. Press ▲ or ▼ to set the voltage.

For lithium battery, set the voltage from 12.0V to 14.0V. For non-lithium battery, set the voltage from 13.0V to 15.0V.

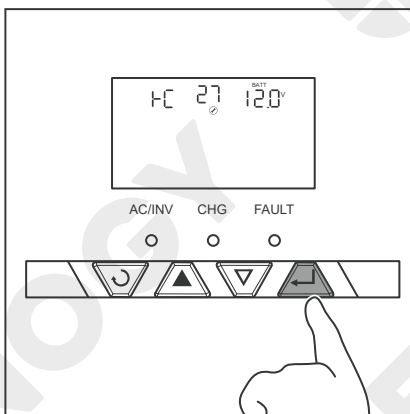

22. After selection, Press ← to save settings.

# Working

REGO 12V 3000W Inverter Charger combines an inverter charger with an automatic transfer switch into one complete system. Featuring a three-stage battery charging mode when connected to the utility AC input, the inverter charger can meet powerful needs as well as charge your battery bank. As a power supply, it is capable of producing cleaner, smoother, and more reliable electricity to address your diverse needs.

The inverter charger is equipped with a 30A transfer relay switch that switches between the charging and the standby mode depending on availability of AC input. If AC is present, the transfer relay bypasses up to 30A of the incoming AC input through the inverter to power the AC loads on the inverter's output. Simultaneously, the inverter charger charges the battery up to 75 Amps. In the event that charger charges the battery up to 75 Amps will power the loads through the battery bank.

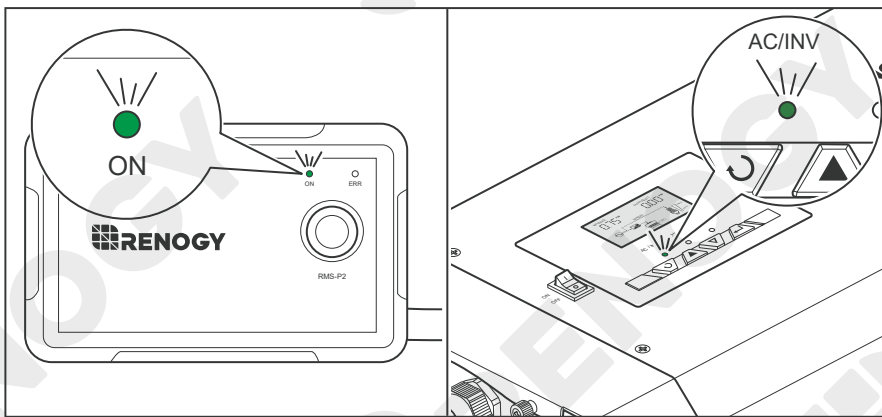

1. The ON indicator of the wired remote control and the AC/INV indicator of the inverter charger flash green when the inverter charger is powering loads from the battery.

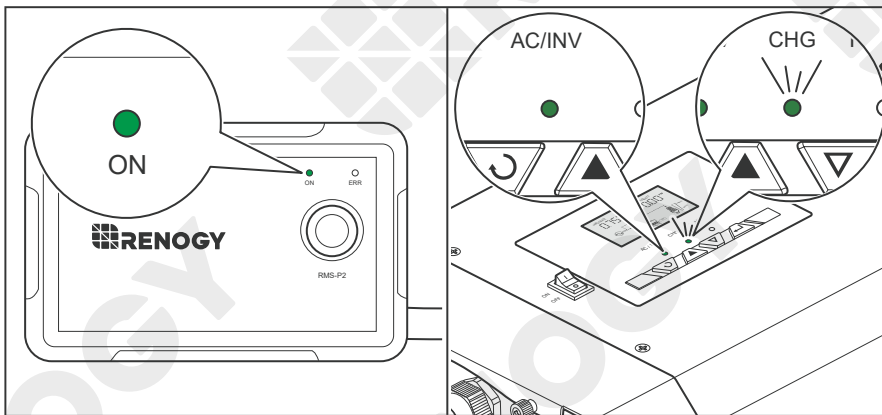

2. The ON indicator of the wired remote control and the AC/INV indicator of the inverter charger are solid green when the inverter charger is powering the loads through an AC Input Source, and when the inverter charger starts to charge the battery at the same time. The CHG indicator flashes green.

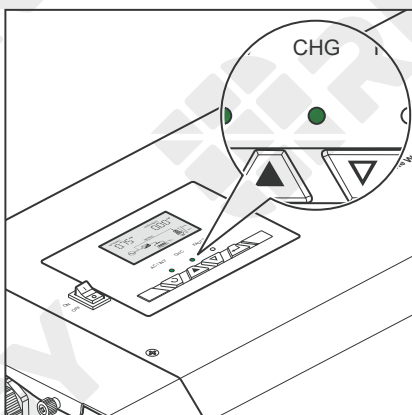

3. When the battery is fully charged, the CHG indicator is solid green.

# Working

## CAUTION

- If the AC/INV indicator and CHG indicator do not light up as described in this user manual, but the power supply equipment (batteries and AC input source) is operating normally, the inverter charger needs troubleshooting. Please contact our customer service through [renogy.com/contact-us/](https://renogy.com/contact-us/).

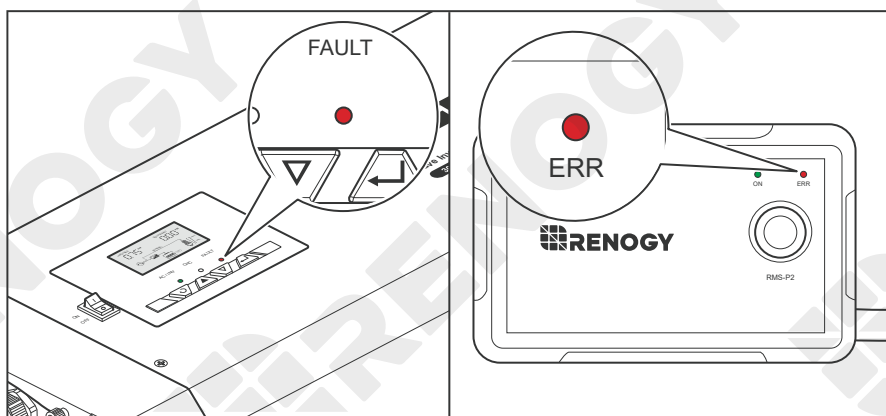
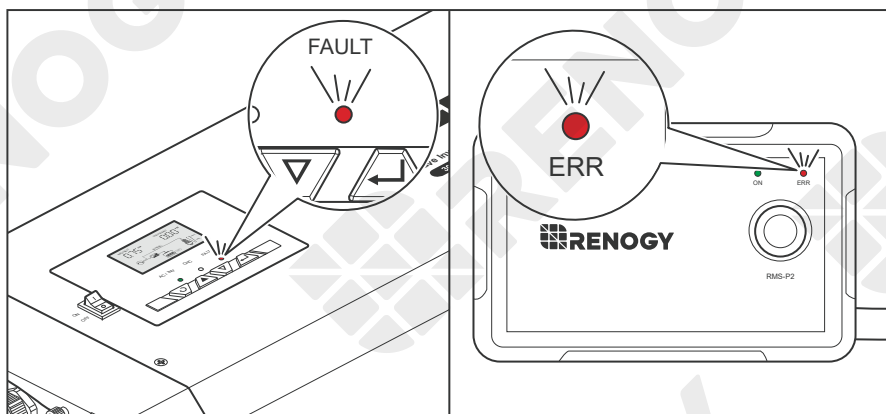
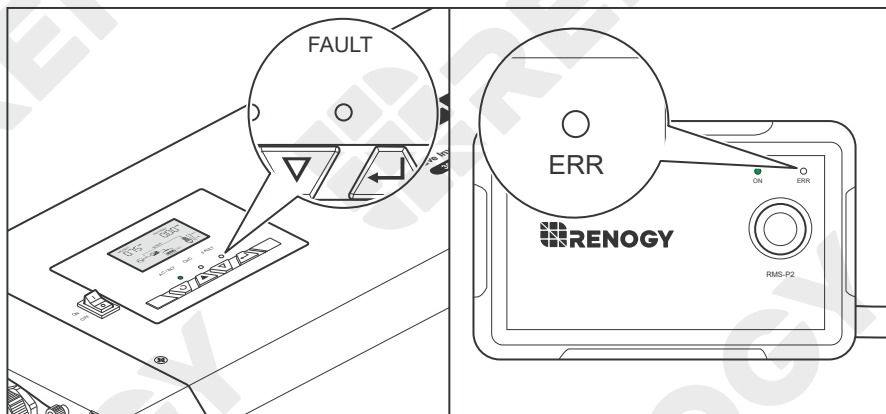

4. Under normal conditions, FAULT indicator of the inverter charger and the ERR indicator of the wired remote control will not light up.

5. If both the FAULT and ERR indicators flash red, and the buzzer sounds at the same time (0.5s), it means warnings are provided by the inverter charger. For details, refer to [Warning/Fault Codes](#) in this user manual.

6. If both the FAULT and ERR indicators are always in red, and the buzzer sounds long, it means that the inverter charger needs troubleshooting. For details, refer to [Warning/Fault Codes](#) in this user manual. For more technical instructions, contact our customer service through [renogy.com/contact-us/](https://renogy.com/contact-us/).

# Working Logic

Power Supply Logic

Charging Logic

Heat Dissipation Logic

## Power Supply Logic

Battery Voltage	AC Input	Power Supply Equipment
10.5V to 16V ( $\pm 0.3V$ )	OFF	Battery
< 10.5V ( $\pm 0.3V$ )	OFF	—
—	ON	AC Input

If the inverter charger is connected to the battery or the AC input is powered off, the battery starts to supply power to the load when the battery voltage ranges from 10.5V to 16V ( $\pm 0.3V$ ). If the battery voltage is less than 10.5V ( $\pm 0.3V$ ), the battery stops supplying power to the load.

If the inverter charger has been connected to the AC input and is in the power supply state, the AC input starts to supply power to the load.



### CAUTION

- You can set the output priority in Program 01. For details, refer to [Program Codes](#) in this user manual.

## Charging Logic

### Working conditions

If the inverter charger is connected to the AC input and is in the power supply state, the inverter charger will automatically recognize the battery voltage and charge the battery.

Battery Voltage	Charging Status
Less than the preset value	Start charging
Equal to or greater than the preset value	Stop charging



### CAUTION

- The preset value varies according to battery types. For details, refer to [Setting Battery Type](#) in this manual.

## ■ Battery Charging Stages

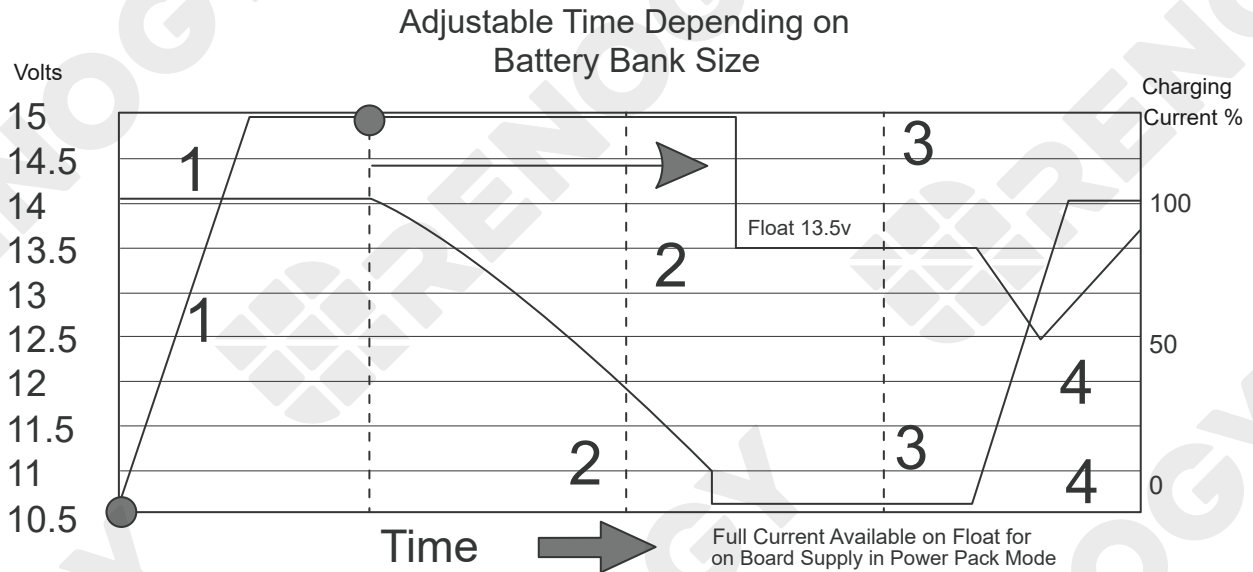

The New Battery Chargers And Boosters Offer The Fastest Charge Rate Currently Available

Step 1 = Constant Current Charge  
Step 3 = Constant Voltage at 13.5V

Step 2 = Absorption Charge at 14.4V/14.8V  
Step 4 = Low Voltage Reset to Step 1

**Bulk Stage:** The charger will supply constant current until the battery voltage reaches the boost voltage. The software will calculate the time to start charging until the battery voltage drops below the boost voltage of 0.3V. This time is referred as  $T_0$ .  $T_0 \times 10 = T_1$ .

**Boost Stage:** The charger will supply constant voltage and reduce the current slowly through this stage. The charger will stay in this stage until  $T_1$  has run out. After this time the charger will enter the float stage. This stage will last between 1 hour and 12 hours depending on  $T_1$ .

### **i** NOTE

- The stage is determined by internal software in the inverter charger.

**Float Stage:** During this stage the charger will supply a constant voltage which is determined by the battery selected and will keep current at a minimum. This stage acts as a trickle charger.

**Equalization:** This stage is only available for batteries with equalization, such as flooded. During this stage the batteries are charged at a higher voltage than normal and for most batteries this could cause damage. Refer to the user manual of the battery or contact the manufacturer to see if this stage is needed.

## Heat Dissipation Logic

The inverter charger uses the fan for heat dissipation. The working logic of the fan is as follows:

Inverter Charger	Fan
Working properly	The fan works for 1 minute every 30 minutes.
AC output current	When AC output current $\geq 35\%$ of rated current of the AC load, the fan starts working. When AC output current $< 35\%$ of rated current of the AC load, the fan stops working.
DC input current	When DC input current $\geq 10A$ , the fan starts working. When DC input current $< 10A$ , the fan stops working.
Temperature	When the temperature of the inverter charger $\geq 50^{\circ}C$ , the fan starts working. When the temperature of the inverter charger $< 50^{\circ}C$ , the fan stops working.

# Power off

Main Switch

Wired Remote Control

## Main Switch

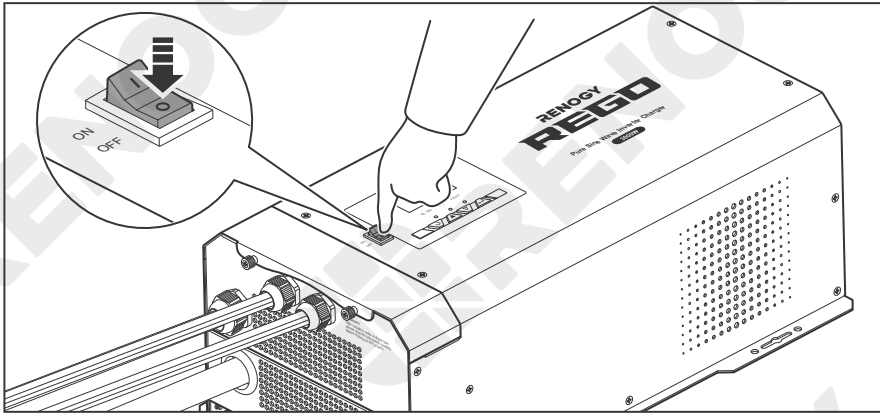

1. Press the main switch of the inverter charger to "OFF" to turn it off.

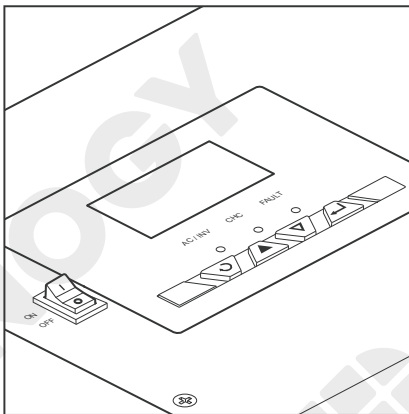

2. The LCD and the LED indicators go out when the inverter charger is powered off.

## Wired Remote Control

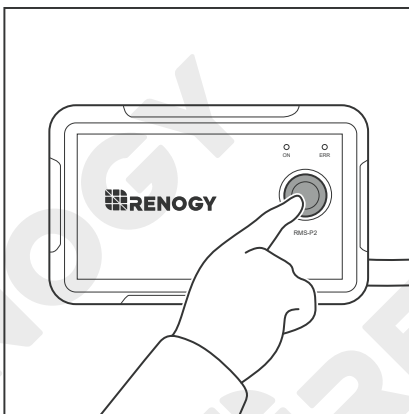

1. When using a wired remote control, press the button on the wired remote control to turn off the power.

# Power off

Main Switch

Wired Remote Control

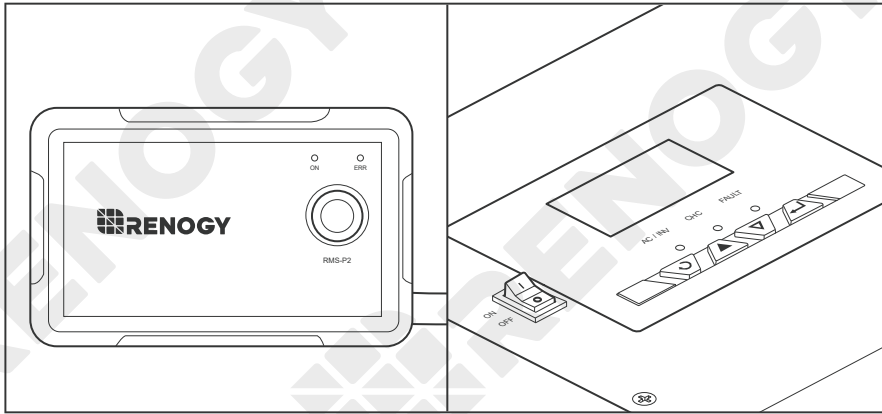

2. The LCD and LED indicators of the inverter charger as well as the ON indicator of the wired remote control go off when the inverter charger is powered off.

# Overcurrent Protection

The inverter charger is integrated with two circuit breakers which ensure that the inverter charger keeps operating even when the input/output stops working. When the input/output circuit breaker is activated, a manual reset is required to resume operation.

## WARNING

- Risk of electric shock! Turn off the inverter charger and the power devices connected to it when the circuit breaker is reset.
- Wear proper protective equipment and use insulated tools during operation. Be careful when touching bare terminals of capacitors as they may retain high lethal voltages even after the power is removed.

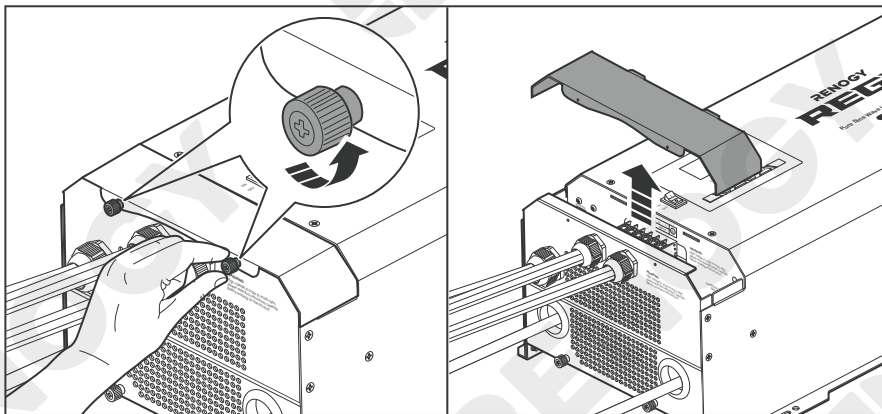

1. Turn the two upper panel screws counterclockwise by hand or a Phillips screwdriver, and remove the Top Plate.



2. When the AC input current exceeds 40A, the Input Circuit Breaker will automatically pop out. Press the CHARGER INPUT PROTECT button to reset the circuit breaker.

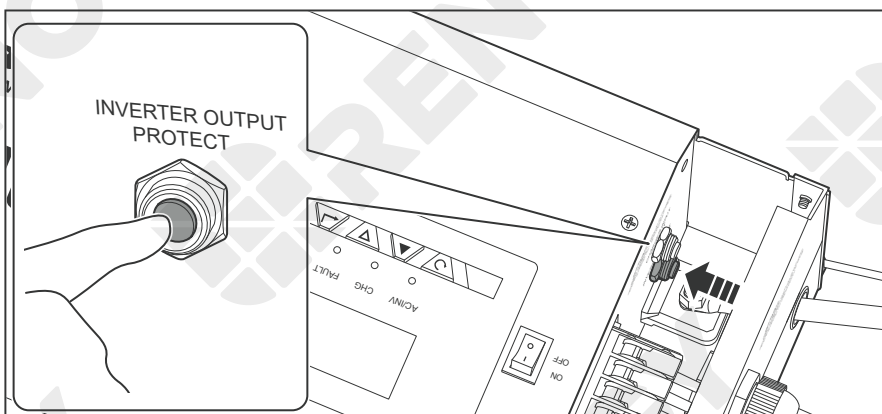

3. When the AC output current exceeds 30A, the Output Circuit Breaker will automatically pop out. Press the INVERTER OUTPUT PROTECT button to reset the circuit breaker.

## NOTE



- After resetting, install the Top Plate back to the inverter charger.

# LED Indicators



Indicator of the Inverter Charger

Indicator of the Wired Remote Control

## Indicator of the Inverter Charger

LED Indicator		Parameter	
<b>AC/INV</b> ○	Green	Solid ●	Output is powered by an AC source in line mode.
		Flashing 	Output is powered by battery or in invert mode.
<b>CHG</b> ○	Green	Solid ●	Battery is fully charged.
		Flashing 	Battery is being charged.
<b>FAULT</b> ○	Red	Solid ●	Fault For details, read <a href="#">Warning/Fault Codes</a> in the user manual.
		Flashing 	Warning For details, read <a href="#">Warning/Fault Codes</a> in the user manual.

## Indicator of the Wired Remote Control

LED Indicator		Parameter	
<b>ON</b> ○	Green	Solid ●	Output is powered by an AC source in line mode.
		Flashing 	Output is powered by battery or in invert mode.
<b>ERR</b> ○	Red	Solid ●	Fault
		Flashing 	Warning

# Program Codes

The inverter charger is fully programmable. You may change the respective parameter by going to the Program Code listed below.

## ■ Operation Methods

- (1). Long press  $\leftarrow$  until the LCD enters the setting mode.
- (2). Press  $\blacktriangle$  or  $\blacktriangledown$  to select programs.
- (3). Press  $\leftarrow$  to enter settings.
- (4). Press  $\blacktriangle$  or  $\blacktriangledown$  to set parameters.
- (5). Press  $\leftarrow$  to save settings.

## NOTE

- Restarting the inverter controller is required if changes are made to frequency, output voltage, charging current, and AC input voltage.

Setting Programs:

Icon	Description	Details	
	Exit setting mode		Escape

## ■ 01 Utility Priority and Battery Priority



### Utility Priority

The default setting is Utility Priority (Ut1). Under this setting, once the inverter charger is connected to the utility power, it will power the loads using the electricity from shore supply. The inverter charger will start charging the battery bank using the AC source, if necessary. In case of power outage, the system automatically switches to battery-powered mode.

### Battery Priority

The optional setting is Battery Priority (SbU). Under this setting, the inverter charger will provide power using the connected battery bank even when it detects an AC source. When the battery voltage reaches the low voltage setting point in Program 12, the inverter charger will power the loads using the connected AC source but will not charge the battery bank.

Detailed settings of Program 01 are as follows:

Icon	Description	Details	
	Output source priority for the load	Utility Priority 	Utility is the preferred power source for loads. Battery will provide power to the loads only when utility power is not available.
		Battery priority 	Battery is the preferred power source for loads. Utility provides power to the loads only when battery voltage drops to either low-level warning voltage or the setting point in Program 12.

# Program Codes



## NOTE

- After settings, disconnect the inverter charger from the AC source/shore power. Turn off the inverter charger and wait for 10 seconds. Turn it on and settings will take effect.

### ■ 03 AC Input Voltage Range



By default, the inverter charger is set to a narrow input voltage range for which the inverter charger will work in Utility mode. It is recommended to keep in this mode if connecting the inverter charger to sensitive electronic devices such as computers and TVs as the narrow mode reduces the switching time from external power to battery.

Selecting a wide input voltage range is recommended when you need power and might be running a generator as they tend to have wider tolerance for a disturbed waveform or are having issues with the stability of the main utility line. This will have a wider range to prevent switching to backup battery mode if utility power is within the wider range.

Icon	Description	Details	
03 	Input voltage range	03 <u>UPS</u> 	Wide Utility effective range: Nominal output voltage: -23% to +15%
		03 <u>RPL</u> 	Narrow (default) Utility effective range: Nominal output voltage: -15% to +15%

### ■ 04 Power Saving Mode

Power saving is designed to conserve battery power when AC input is not or rarely required by the loads. In this mode, the inverter charger pulses the AC output looking for an AC load (i.e., appliance). Whenever an AC load (greater than 50 watts) is turned on, the inverter charger recognizes the need for power and automatically starts inverting, and the output goes to full voltage. When there is no load (or less than 50 watts) detected, the inverter automatically goes back into search mode to minimize energy consumption from the battery bank. In Power Saving Mode, the inverter charger will draw power mainly in sensing moments, thus the idle consumption is significantly reduced.

Icon	Description	Details	
04 	Enable or disable power saving mode	Saving mode disabled (default) 04 <u>PSd</u> 	If the power saving mode is disabled, the output of the inverter charger will be available at all times.
		Saving mode enabled 04 <u>PSE</u> 	If the power saving mode is enabled, the output of the inverter charger will be off until a load greater than 50 watts is detected.

### ■ 05 Setting battery Type

For more instructions, read [Setting Battery Type](#) in the user manual.

# Program Codes

## ■ 07 Auto Restart Temperature Fault

The operating temperature range for the inverter charger is 32°F to 104°F or 0°C to 40°C. If the temperatures of internal power components begin to exceed their safe operating temperature, the inverter charger shuts down to protect itself from damage. This setting controls whether the inverter charger automatically restarts after the inverter charger cools down or whether you have to manually restart the inverter charger.

Icon	Description	Details
07 ⓘ	Auto restart upon overtemperature	07 <u>LTd</u> Restart disabled (default)
		07 <u>LTE</u> Restart enabled

## ■ 09 Output Frequency

The factory default frequency for the inverter charger is 60 Hz. Normally, manufacturers build electrical devices for a certain amount of Current, Voltage and Hertz (Cycles) as shown in the specifications. The Current is dependent of the Voltage and the Hertz supplied to an electric motor or appliance.

Icon	Description	Details
09 ⓘ	Output frequency	09 <u>50</u> Hz 50 Hz
		09 <u>60</u> Hz 60 Hz (default)

## ■ 11 Maximum Utility Charging

The inverter charger can operate like the battery charger, converting the incoming AC input into the DC recharging power.

Icon	Description	Details
11 ⓘ	Maximum utility charging current	11 <u>5A</u> The default is the maximum value (75A-3KW), with a 5A minimum.

## ■ 12 Low Battery Voltage Setpoint

The purpose of this setpoint is to protect the batteries from being overdischarged. It assumes that Battery Priority is set on Program 01. When the battery voltage reaches the preset value in Program 12, the inverter charger will stop supplying power to loads. Once the utility power is detected, the utility power/generator will supply power to the loads.

# Program Codes

Icon	Description	Details	
12 ⌚	Low battery voltage point when the power source switches from battery to utility	12 ⌚	 <p>The range is from 10.5V to 12.5V. If the battery voltage is below this setpoint, no power is given to loads from the battery. By default this is the low battery voltage in the charging table for all batteries. Increment of each press is 0.1V for 12V.</p>

## 13 Overvoltage Battery Recovery

This setpoint indicates that the voltage returns to normal value when a battery has been overcharged or is over the voltage limit. The inverter charger will be in a fault state if the battery voltage is above this designated setpoint and resume normal battery operation when reaching this setpoint.

Icon	Description	Details	
13 ⌚	Threshold to trigger overvoltage battery recovery	13 ⌚	 <p>Range: 13.0V and 15.5V. Otherwise, the output of bypass ranges from 13.0V to 15.5V. The voltage is set by you on demand. Increment of each press is 0.1V.</p>

## 18 Alarm Control / Behavior

When a fault occurs on the inverter charger, an alarm is triggered and the inverter charger and stops working. You can enable or disable the alarm on demand.

Icon	Description	Details	
18 ⌚	Beeps while function keys are pressed	18 ⌚	607 Alarm on (default)
		18 ⌚	60F Alarm off

### Alarm Parameters:

The buzzer beeps when the inverter charger encounters any of the following: low voltage shutdown, high voltage shutdown, overheating protection, and overload protection. For details, see the table below:

Action & Alarm	Buzzer
Pressing Function Keys	The buzzer will beep for 0.5s
Working Mode Transfer	The buzzer will beep for 0.5s
Overheating / Overload Alarm	The buzzer will beep for 0.3s every 1s
Low-voltage / High-voltage Alarm	The buzzer will beep for 0.2s every 0.5s

# Program Codes

## ■ 19 Screen Mode

By default, after 1 minute of inactivity, the inverter charger will return to the screen displayed at startup. You can change this mode to continue viewing the last screen before inactivity.

Icon	Description	Details	
19 ⊗	Auto return to default display screen	Return to default display screen (default) 19 ESP ⊗	The display screen will return to default screen (Input voltage / Output voltage) after 1 minute of inactivity.
19 ⊗	Auto return to default display screen	Stay at latest screen 19 FEP ⊗	Display screen will stay on current screen until you change it.

## ■ 20 LCD Screen Mode

The LCD on the inverter charger will always stay on by default. You can change the mode in Program 20.

Icon	Description	Details	
20 ⊗	LCD Screen Control	20 LON ⊗	LCD screen will stay on (default)
		20 LOF ⊗	LCD screen will turn off after inactivity.

## ■ 22 Normal Mode Sound

By default, the inverter charger will emit an audible noise when toggling any of the buttons. This mode disables the sound for a quieter working mode.

Icon	Description	Details	
22 ⊗	The beeps when pressing any button can be disabled with this setting.	22 AON ⊗	Alarm on (default)
		22 AOF ⊗	Alarm off

## ■ 25 Record Fault Code

The inverter charger will demonstrate the fault code.

# Program Codes



Icon	Description	Details
25 ⓘ	Record Fault code	25 FEN ⓘ Record enabled
		25 FdS ⓘ Record disabled (default)

## ■ 26 Boost Charging

For more instructions, read [Setting Battery Type](#) in the user manual.

### **i** NOTE

This setting will not be modifiable if you choose a preset battery voltage. When the voltage reaches the preset voltage, the charging will stop.

Icon	Description	Details
26 ⓘ	Bulk charging voltage (C.V voltage)	Set the bulk charging voltage after selecting the user mode in Program 94. For non-lithium battery, set the voltage from 13.0V to 15.0V. BATT <div style="text-align: center;">  </div>
	Maximum charging voltage	Set the maximum charging voltage after selecting the user mode in Program 94. For lithium battery, set the voltage from 13.0V to 15.5V. <div style="text-align: center;">  </div>

## ■ 27 Float Charging

For more instructions, read [Setting Battery Type](#) in the user manual.

### **i** NOTE

- This setting will not be modifiable if you choose a preset battery voltage.

# Program Codes

Icon	Description	Details
27 ⓘ	Setting Battery Type  FLV	Set the floating charging voltage after selecting the user mode in Program 94. For non-lithium battery, set the voltage from 13.0V to 15.0V. BATT  FLV 27 13.0 <sup>BATT</sup> V
	Battery low voltage open charging (for lithium battery)  LC	Set battery low voltage open charging after selecting the user mode in Program 94. For non-lithium battery, set the voltage from 12.0V to 14.0V.  LC 27 12.0 <sup>BATT</sup> V

## 29 Low DC Cut-off Voltage

This program determines the cut-off voltage range for the battery input of the inverter charger. Upon reaching this voltage, the inverter charger will cut off operation until the battery can go above this voltage level.

### NOTE

- This setting must be at least 0.5V lower than the Low Battery Voltage Alarm in Program 98.

Icon	Description	Details
29 ⓘ	Low DC cut-off voltage	The default setting is 10.0V. Setting range is from 10.0V to 12.0V with increments of 0.1V.  E0V 29 10.0 <sup>BATT</sup> V

## 93 Input Frequency Range

The factory default frequency for inverters is 60 Hz. Normally, manufacturers build electrical devices for a certain amount of Current, Voltage and Hertz (Cycles) which is mentioned on the name plate. The Current is dependent of the Voltage and the Hertz supplied to an electric motor or appliance. This program allows you to set the frequency range of the AC input source. Special cases might require a wider frequency range than normal utility and generator outputs.

Icon	Description	Details
93 ⓘ	Frequency Range	Special 40 Hz-70 Hz 93 ALT
		General 50 Hz 45 Hz-55 Hz / 60 Hz 55 Hz-65 Hz 93 GEN



# Program Codes

## ■ 94 Selection of Battery Type Custom

For more instructions, read [Setting Battery Type](#) in the user manual.



### NOTE

- This setting will not be modifiable if you choose a preset battery voltage.

Icon	Description	Details	
94 	Selection of battery type	Lithium battery 94 ALB 	The battery charge voltage and battery low open charging can be set up in Program 26, 27
		Non-lithium battery 94 NLP 	The battery charge voltage can be set up in Program 26, 27

## ■ 95 Battery High Voltage for Dry Contacts

The inverter charger have functions to automatically start and stop a generator for supplementing charge. The auto generator feature starts the generator with the use of Normally Closed (NC) contacts of the relay that “opens” when the battery voltage drops to the programmed value of Program 96. The Normally Open (NO) relay “closes”, and the generator starts to charge the battery bank. When the battery is recharged and its voltage rises to the programmed value of Program 95, the NC (close) contacts and NO (open) contacts of relay reset and the generator will stop / shut down the generator automatically. The inverter charger will then transfer back to Inverting Mode.

Icon	Description	Details
95 	Battery high voltage trip	<p>The dry contacts will switch from NO to NC when the battery voltage reaches the preset value in Program 95. This value cannot be lower than fast charge voltage. Set the voltage from 13.0V to 15.5V.</p> <p style="text-align: center;">  </p>

## ■ 96 Low Voltage Trip for Dry Contacts

The inverter charger can automatically start and stop a generator for supplementing charge. The auto generator feature starts the generator with the use of Normally Closed (NC) contacts of the relay that “opens” when the battery voltage drops to the programmed value of Program 96, Low Battery Voltage Setpoint. The Normally Open (NO) relay “closes”, and the auto generator start function enables the generator to charge the battery bank. When the battery is recharged and its voltage rises to the programmed value of Program 95, the NC (closes) contacts and NO (open) contacts of relay reset. Dry contacts trigger when the low voltage setpoint is reached and trigger again when upper voltage limit is reached to stop. The inverter charger will then transfer back to Inverting Mode.

# Program Codes

Icon	Description	Details
96 ⌚	Battery low voltage trip	When battery voltage reaches the setpoint, the dry contact switches from NC to NO. This value cannot be lower than the cut-off point of the low battery. The setting range is from 10.5V to 12.5V for 12V. Increment of each press is 0.1V for 12V.  <div style="text-align: center;"> </div>

## ■ 97 Dry Contacts Control

To modify the setting point of battery in Program 95 and Program 96, enable dry contact control. This allows control over the auto generator function.

Icon	Description	Details
97 ⌚	Dry contacts control	If the inverter charger is set in dcd (dry contact disable) mode, dry contact function is disabled, When this setting is enabled, the dry contacts voltages are set.  <div style="text-align: center;"> </div>
		If the inverter charger is set in dce (dry contact enable) mode, dry contact function is enabled and 95, 96 can be set up in program.  <div style="text-align: center;"> </div>

## ■ 98 Low Battery Voltage Alarm

Users can select to have the inverter charger sound an alarm at a programmable battery voltage. The value set in Program 98 should be higher than Program 29, Low DC Cut-off Voltage, as it will warn users that the battery is discharging before ultimately being disconnected.

Icon	Description	Details
98 ⌚	Low voltage battery alarm	The default is 10.5V. The setting range is 10.5V to 12.5V with an increment of 0.1V. This setting will be at least 0.5V greater than setting Program 29.  <div style="text-align: center;"> </div>







## ■ 99 AC output Voltage

Allows users to customize AC output voltages for devices that might need to meet a very specific AC input criteria.

# Warning/Fault Codes

When the inverter charger needs troubleshooting, the FAULT indicator of the inverter charger and the ERR indicator of the wired remote control are flashing red, while the buzzer beeps long and the LCD displays the FAULT code. Troubleshoot typo according to the following table.

For more technical support, contact our custom service through [renogy.com/contact-us](https://renogy.com/contact-us).







Icon	Warning Event
	03: Battery overvoltage alarm Shut down the inverter charger. Disconnect all cables. Check the battery voltage. If the battery is damaged, replace it.
	04: Battery low voltage alarm 1. Charge the battery immediately. 2. Check the battery voltage to conform whether the battery is damaged. If the battery is damaged, replace it.
	05: Over-temperature alarm 1. Check whether fan thermal control is blocked and affect heat dissipation. 2. Check whether the fans are running. If they are not running, the fans need troubleshooting. Contact our customer service through <a href="https://renogy.com/contact-us/">renogy.com/contact-us/</a> . 3. Decrease the ambient temperature and the load power. 4. Shut down the inverter charger and restart it when its temperature decreases.
	07: Overload alarm Reduce the quantity and power of the load.
	88: The inverter transformer is phased in reverse Shut down the inverter charger. Disconnect the AC input, and check whether the AC input wiring is correct.
	89: The frequency of main power is out of range Shut down the inverter charger. Disconnect the AC input power. Check that the AC input is within the rated frequency range of 40 Hz to 70 Hz.

When the inverter charger needs troubleshooting, the FAULT indicator of the inverter charger and the ERR indicator of the wired remote control are solid red, while the buzzer beeps long and the LCD displays the FAULT code. Troubleshoot faults according to the following table.

For more technical support, contact our custom service through [renogy.com/contact-us/](https://renogy.com/contact-us/).

Icon	Warning Event
	02: Short circuit of the inverter charger Shut down the inverter charger. Check whether the load is short-circuited. If it is, replace the load and restart the inverter charger.

# Warning/Fault Codes

Icon	Warning Event
	<p>03: Battery high voltage</p> <p>Shut down the inverter. Disconnect all cables connected to it. Check the battery voltage. If the battery is damaged, replace it.</p>
	<p>04: Battery low voltage</p> <ol style="list-style-type: none"> <li>1. Charge the battery immediately.</li> <li>2. Check the battery voltage to confirm whether the battery is damaged. If the battery is damaged, replace it.</li> </ol>
	<p>05: The heat sink of inverter charger is overheated</p> <ol style="list-style-type: none"> <li>1. Check whether fan thermal control is blocked and affect heat dissipation.</li> <li>2. Check whether the fans are running. If they are not running, the fans need troubleshooting. Contact our customer service through <a href="https://renogy.com/contact-us/">renogy.com/contact-us/</a>.</li> <li>3. Decrease the ambient temperature and the load power.</li> <li>4. Shut down the inverter charger and restart it when its temperature decreases.</li> </ol>
	<p>06: The output voltage of inverter charger is too high or too low</p> <p>Shut down the inverter charger and restart it. If the fault still persists, contact our custom service through <a href="https://renogy.com/contact-us/">renogy.com/contact-us/</a>.</p>
	<p>07: Inverter charger overloaded</p> <p>Reduce the quantity and power of the load.</p>
	<p>98: The transformer of inverter charger is overheated</p> <ol style="list-style-type: none"> <li>1. Check whether fan thermal control is blocked and affect heat dissipation.</li> <li>2. Check whether the fans are running. If they are not running, the fans need troubleshooting. Contact our customer service through <a href="https://renogy.com/contact-us/">renogy.com/contact-us/</a>.</li> <li>3. Decrease the ambient temperature and the load power.</li> <li>4. Shut down the inverter charger and restart it when its temperature decreases.</li> </ol>
	<p>99: Slow start failure of the inverter charger</p> <p>If the inverter fails to start slowly, contact our custom service through <a href="https://renogy.com/contact-us/">renogy.com/contact-us/</a>.</p>

# Technical Specifications

Inverter Specifications	
Rated Output Power	3000W
Surge Power (1 second)	9000W
Surge Power (3 seconds)	4500W
Surge Power (10 seconds)	3600W
Nominal Output Voltage RMS	120V AC (100V to 120V AC, 5V intervals)
Output Frequency	50 Hz ( $\pm 0.3$ Hz) or 60 Hz ( $\pm 0.3$ Hz)
Output Wave Form	Pure Sine Wave
Output Overload	105% < Load < 120% ( $\pm 10\%$ ) Fault (Turn off output after 10 seconds) 120% < Load < 150% ( $\pm 10\%$ ) Fault (Turn off output after 3 seconds) 150% < Load ( $\pm 10\%$ ) Fault (Turn off output after 1 seconds)
Nominal Input Voltage	12V DC
Input Voltage Range	11V to 16V DC ( $\pm 0.3$ V)
Low DC Warning Voltage	11V DC ( $\pm 0.3$ V)
Low DC Cut-off Voltage	10.5V DC ( $\pm 0.3$ V)
Short Circuit Protection	Software Protection
Nominal Efficiency	> 90% Peak
No Load Power Consumption	Normal: < 30W

Charger Specifications	
Nominal Input Voltage	120V AC
Input Voltage Range	90V to 138V AC
Input Frequency Range	40 Hz to 70 Hz
Input Wave Form	Sine Wave (Utility or Generator)
Power Factor	0.9 to 1
Optimal Efficiency	> 85%
Output Current	5A to 75A Configurable, 5A intervals



# Technical Specifications

Charger Specifications	
Short Circuit Protection	Circuit Breaker
Output Overload	120% < Load < 150% ( $\pm 10\%$ ) Fault (Turn off output after 60 seconds) 150% < Load ( $\pm 10\%$ ) Fault (Turn off output after 1 second)
Overcharge Protection Shutdown	16V for 12V DC

Transfer Switch Specifications	
Transfer Time	10 ms
Line Mode Efficiency	> 95%
Transfer Relay Rating	40A Maximum Bypass

General Specifications	
Battery Types	Gel, AGM, SLA, Flooded, Calcium, Li, User Mode
Operating Temperature Range	-20°F to 104°F or -20°C to 40°C
Storage Temperature	-22°F to 158°F or -30°C to 70°C
Humidity	0% to 95%
Noise	< 50 dB
Dimensions	20.1 x 11.2 x 7.6 in / 510 x 285 x 193 mm
Weight	63.5 lbs / 28.8 Kg
Certifications	ETL listed to CSA Standard C22.2 No. 107.1 and UL458 with marine supplement FCC part 15 Class A

Wired Remote Control	
List Dimensions	2.8 x 4.3 x 1.3 in / 70 x 110 x 31.8 mm
Wire Length	Approx 16.4 ft

## NOTE

- Product specifications are subject to change without further notice.

# Dimensions

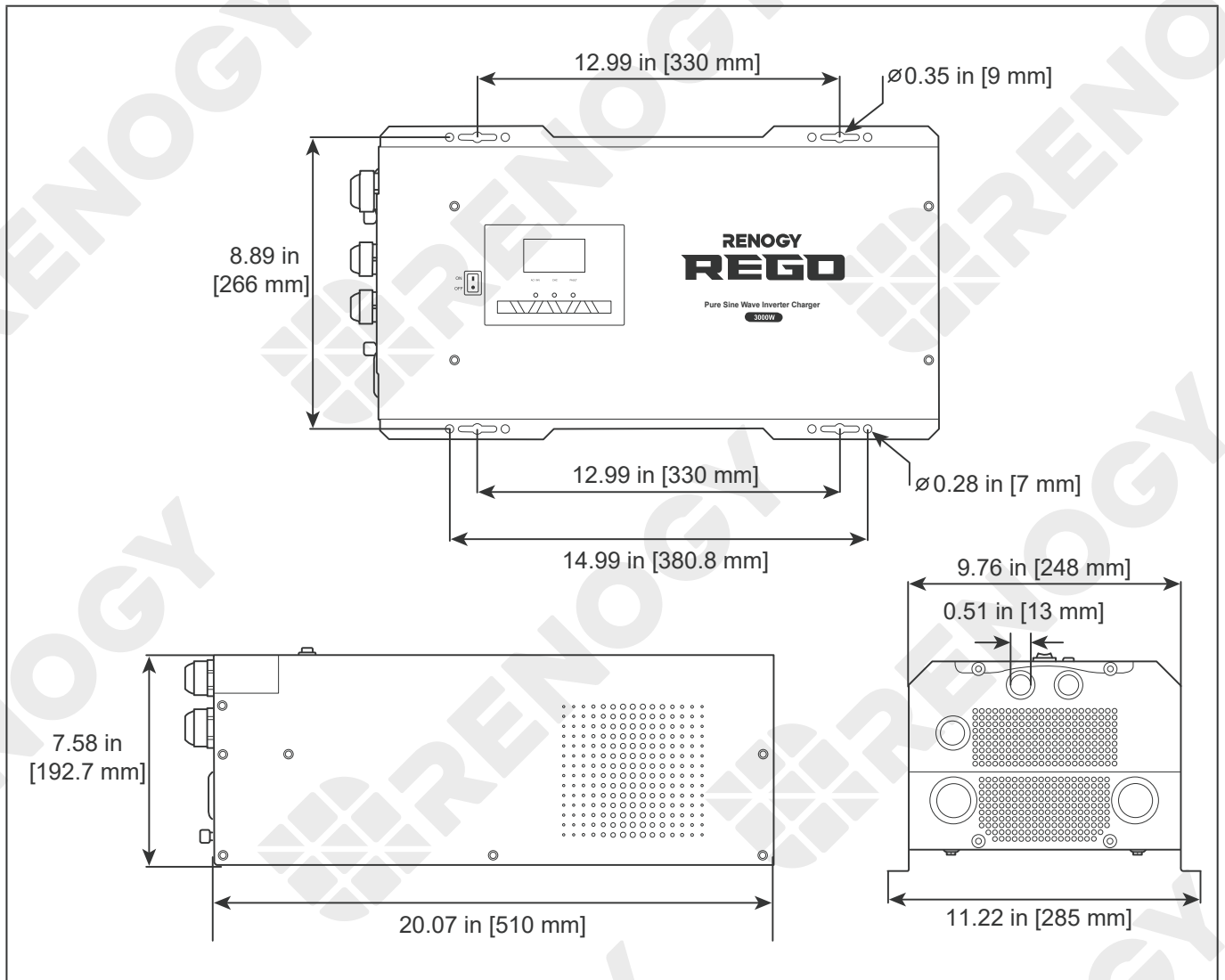

## NOTE

- Dimension tolerance:  $\pm 0.2$  in (0.5 mm)

# Maintenance

Inspection

Cleaning

Storage

## Inspection

For optimum performance, it is recommended to perform these tasks regularly.

- Ensure the inverter charger is installed in a clean, dry and ventilated area.
- Ensure there is no damage or wear on the cables.
- Ensure the firmness of the connectors and check if there are any loose, damaged or burnt connections.
- Make sure the AC/INV indicator, CHG indicator and FAULT indicator are in proper condition.
- Ensure there is no corrosion, insulation damage, or discoloration marks of overheating or burning.
- If the inverter charger is dirty, use a damp cloth to clean the outside of the device to prevent dust and dirt from accumulating. Before the inverter charger is powered on, make sure it is completely dry after cleaning.
- Make sure the ventilation holes are not blocked.



### WARNING

- Risk of electric shock! Make sure that all power supplies are turned off before touching terminals on the inverter charger.

## Cleaning

Follow the steps below to clean the inverter charger regularly.

- Disconnect all cables connected to the inverter charger.
- Wear proper protective equipment and use insulated tools during operation. Be careful when touching bare terminals of capacitors as they may retain high lethal voltages even after power is removed.
- Wipe the housing of the inverter charger and connector contacts with a dry cloth or non-metallic brush. If it is still dirty, you can use household cleaners.
- Make sure the ventilation holes are not blocked.
- Dry the inverter charger with a clean cloth and keep the area around the inverter charger clean and dry.
- Make sure the inverter charger is completely dry before reconnecting it to the battery and AC input.

## Storage

Follow the tips below to ensure that the inverter charger is stored well.

- Disconnect all cables connected to the inverter charger.
- By applying dielectric grease to each connector contact, the dielectric grease repels moisture and protects the connector contacts from corrosion.
- Store the inverter charger in a well-ventilated, dry, and clean environment with the temperature between 22°F to 158°F or 30°C to 70°C.

# Emergency Responses

Fire

Flooding

Smell

Noise

In the event of any threat to health or safety, always begin with the steps below before addressing other suggestions.

- Immediately contact the fire department or other relevant emergency response team.
- Notify all people who might be affected and ensure that they can evacuate the area.

## WARNING

- Only perform the suggested actions below if it is safe to do so.

### Fire

1. Disconnect all cables connected to the inverter charger.
2. Put out the fire with a fire extinguisher. Acceptable fire extinguishers include water, CO<sub>2</sub>, and ABC.

## WARNING

- Do not use type D (flammable metal) fire extinguishers.

### Flooding

1. If the inverter charger is submerged in water, stay away from the water.
2. Disconnect all cables connected to the inverter charger.

### Smell

1. Disconnect all cables connected to the inverter charger.
2. Ensure that nothing is in contact with the inverter charger.
3. Ventilate the room.

### Noise

1. Disconnect all cables connected to the inverter charger.
2. Make sure no foreign objects are stuck in the fan of the inverter charger or the ring terminal.

## NOTE

- The normal noise value of the inverter charger is less than 50dB during operation.

# Technical Support

For additional support, contact the Renogy technical support team through [renogy.com/contact-us](https://www.renogy.com/contact-us). Have the following information available when contacting Renogy.

- Owner name
- Contact information
- Order number
- Purchase channel
- Serial number
- Brief description of the issue



**Renogy offers premium services worldwide:**

<b>North America</b>	US	<a href="https://www.renogy.com">www.renogy.com</a>	CN	<a href="https://www.renogy.cn">www.renogy.cn</a>
<b>Asia/Pacific</b>	UK	<a href="https://uk.renogy.com">uk.renogy.com</a>	CA	<a href="https://ca.renogy.com">ca.renogy.com</a>
	AU	<a href="https://au.renogy.com">au.renogy.com</a>	JP	<a href="https://renogy.jp">renogy.jp</a>
<b>Europe</b>	FR	<a href="https://fr.renogy.com">fr.renogy.com</a>	DE	<a href="https://de.renogy.com">de.renogy.com</a>
	ES	<a href="https://es.renogy.com">es.renogy.com</a>	KR	<a href="https://kr.renogy.com">kr.renogy.com</a>

## FCC Statement

This device complies with Part 15 of the FCC Rules. FCC ID: 2ANPBRMLP4-G2. Operation is subject to the following two conditions:

- (1) This device may not cause harmful interference.
- (2) This device must accept any interference received, including interference that may cause undesired operation.

This equipment has been tested and found to comply with the limits for a Class A digital device, pursuant to Part 15 of the FCC Rules. These limits are designed to provide reasonable protection against harmful interference in a residential installation. This equipment generates, uses and can radiate radio frequency energy and, if not installed and used in accordance with the instructions, may cause harmful interference to radio communications. However, there is no guarantee that interference will not occur in a particular installation. If this equipment does cause harmful interference to radio or television reception, which can be determined by turning the equipment off and on, the user is encouraged to try to correct the interference by one or more of the following measures:

- (1) Orient or relocate the receiving antenna.
- (2) Increase the separation between the equipment and receiver.
- (3) Connect the equipment into an outlet on a circuit different from that to which the receiver is connected.
- (4) Consult the dealer or an experienced radio/TV technician for help.

## FCC Radiation Exposure Statement

This equipment complies with FCC radiation exposure limits set forth for an uncontrolled environment. This equipment should be installed and operated with minimum distance 20 cm between the radiator & your body.

Visit [renogy.com](https://renogy.com) to find relevant documentation or get more support via "[Contact Us](#)".  
Renogy reserves the right to change the contents of this manual without notice.

Join the Renogy Power Plus Community  
by downloading the DC Home App.  
Find your e-warranty here, and more.

