

SEARS

OWNERS
MANUAL

MODEL NO.
247.796890



WARNING

Carefully read and follow Safety Rules, Precautions and Operating Instructions. Failure to do so can result in serious personal injury.

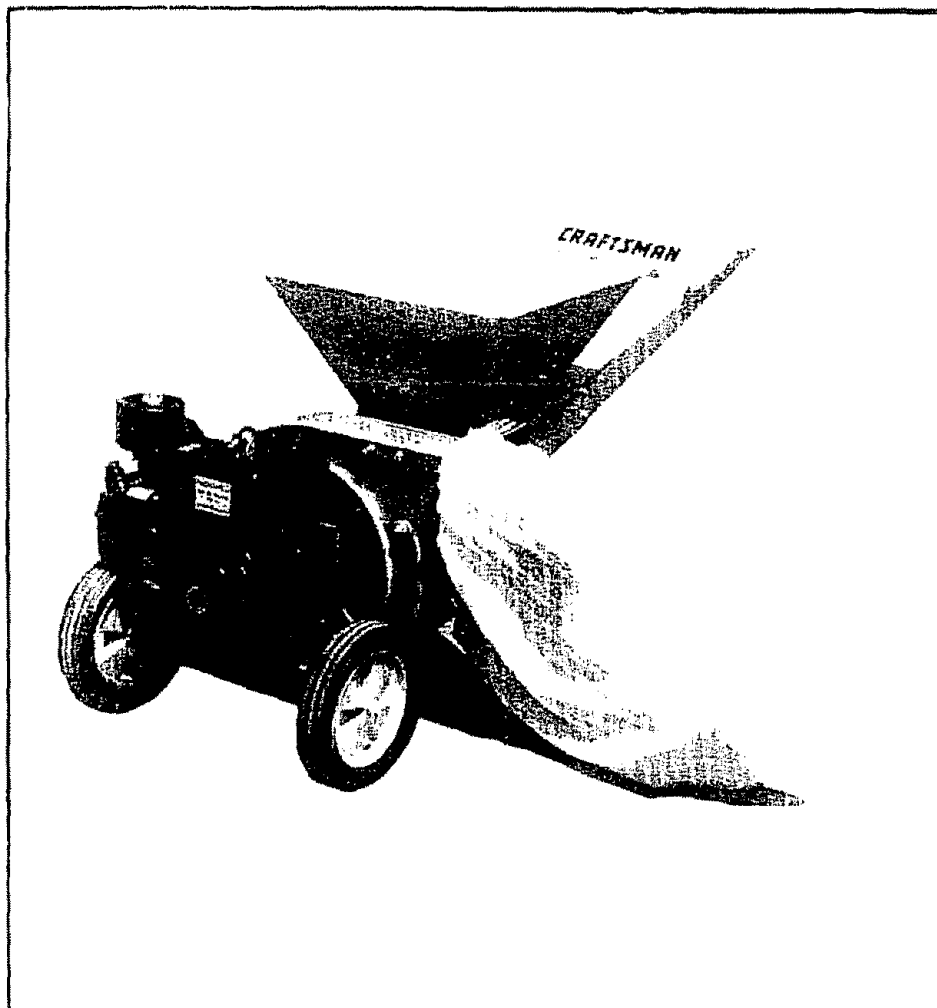

SEARS / CRAFTSMAN®

5 H.P. CHIPPER-SHREDDER

- Assembly
 - Operation
 - Maintenance
 - Repair Parts
- Always wear eye protection during operation

Sold by Sears, Roebuck and Co., Chicago, Ill 60684 U.S.A.

Part No. 770-5875B 8/87

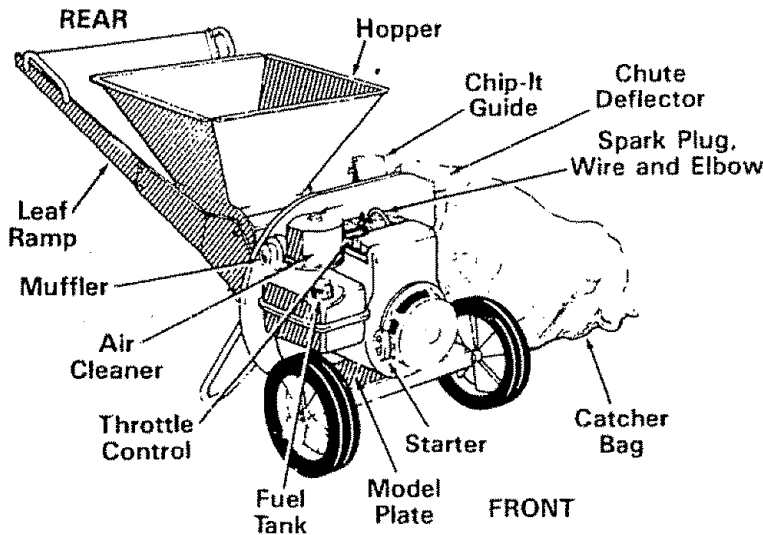

MODEL NUMBER _____
 SERIAL NUMBER _____

THE MODEL AND SERIAL NUMBERS WILL BE FOUND ON THE MODEL PLATE ATTACHED TO THE FRAME. SEE ILLUSTRATION AT LEFT

YOU SHOULD RECORD BOTH MODEL AND SERIAL NUMBERS AND KEEP IN A SAFE PLACE FOR FUTURE REFERENCE.

 Instructions given with this symbol are for personal safety. Be sure to follow them.

INDEX

Warranty	2	Maintenance	9
Rules for Safe Operation	3	Off-Season Storage	11
Assembly	4	Maintenance Check List	12
Operation	6	Trouble Shooting Chart	12
How to Use Your Chipper-Shredder	7	Repair Parts	13-19
Adjustments	9		

MAINTENANCE AGREEMENT

A Sears Maintenance Agreement is available on this product. Contact your nearest Sears store for details.

LIMITED ONE YEAR WARRANTY ON CRAFTSMAN GAS CHIPPER-SHREDDER

For one year from the date of purchase, when this Craftsman Chipper-Shredder is maintained, lubricated and tuned up according to the instructions in the owner's manual, Sears will repair, free of charge, any defect in material and workmanship.

If this Craftsman Chipper-Shredder is used for commercial or rental purpose, this warranty applies for only 30 days from the date of purchase.

This warranty does not cover:

- Expendable items which become worn during normal use, such as blades, blade guides, blade adapters, air cleaners, spark plugs and catcher bags;
- Repairs necessary because of operator abuse or negligence, including bent crankshafts.

WARRANTY SERVICE IS AVAILABLE BY RETURNING THE CRAFTSMAN CHIPPER-SHREDDER TO THE NEAREST SERVICE CENTER/DEPARTMENT IN THE UNITED STATES

This warranty gives you specific legal rights, and you may also have other rights which vary from state to state
 SEARS, ROEBUCK AND CO., Dept. 698/731A, Sears Tower, Chicago, IL 60684



This unit is equipped with an internal combustion engine and should not be used on or near any unimproved forest-covered, brush-covered or grass-covered land unless the engine's exhaust system is equipped with a spark arrester meeting applicable local or state laws (if any). If a spark arrester is used, it should be maintained in effective working order by the operator

In the State of California the above is required by law (Section 4442 of the California Public Resources Code). Other states may have similar laws. Federal law apply on federal lands. A spark arrester muffler is available at your Sears Authorized Service Center (see page 19)

**WARNING**

To reduce the potential for any injury, comply with the following safety instructions. Failure to comply with the instructions may result in personal injury.

RULES FOR SAFE OPERATION

TRAINING

1. Read this owner's manual carefully in its entirety before attempting to assemble or operate this machine. Be completely familiar with the controls and the proper use of this machine before operating it. Keep this manual in a safe place for future and regular reference and for ordering replacement parts.
2. Children must never be allowed to operate this equipment.
3. No one should operate this unit while intoxicated or while taking medication that impairs the senses or reactions.
4. This equipment should never be operated in the vicinity of children, pets or other persons.
5. Never run your machine in an enclosed area as the exhaust from the engine contains carbon monoxide, which is an odorless, tasteless and deadly poisonous gas.
6. Never allow your hands or any part of your body or clothing inside the feeding chamber, discharge chute, or near any moving part while the machine or engine is running.
7. If it is necessary for any reason to inspect or repair the feeding chamber or any part of the machine where a moving part can come in contact with your body or clothing, stop the machine, allow it to cool, and disconnect the spark plug wire from the spark plug before attempting such inspection or repair.

PREPARATION

1. Wear safety glasses provided with your unit while operating the chipper-shredder to prevent injury from any chips which may be ejected out of the openings.
2. Wear proper apparel. Avoid wearing loose fitting clothing. Wear gloves when handling material.
3. **HANDLE FUEL WITH CARE** as gasoline is an extremely flammable fuel.
 - A. Check the fuel before starting the engine. Do not fill the fuel tank indoors, while the engine is running, or while the engine is still hot. Turn the unit off and let the engine cool before refueling.
 - B. Fuel your chipper-shredder in a clean area. Do not smoke while refueling.
 - C. Fuel tank cap must be secure at all times except during refueling.
 - D. Avoid spilling gasoline or oil. Wipe the unit clean of any spilled fuel or oil.
 - E. Store fuel and oil in approved containers, away from heat or open flame, and out of reach of children.
4. This machine should be operated only upon an level earthen surface.
5. Assure that all screws, nuts and bolts and other fasteners are properly secured.

OPERATION

1. When feeding shreddable material into this equipment, be extremely careful that pieces of metal,

rocks, bottles, cans or other foreign objects are not included.

2. If the cutting mechanism strikes any foreign object or if your machine should start making an unusual noise or vibration, immediately stop the engine and disconnect the spark plug wire from the spark plug. Allow the machine to stop and take the following steps:
 - A. Inspect for damage.
 - B. Replace or repair any damaged parts.
 - C. Check for any loose parts and tighten to assure continued safe operation.
3. The engine must be kept clean of debris and other accumulations.
4. Do not allow an accumulation of processed material to build up in the discharge area as this will prevent proper discharge and can result in kick-back from feed opening.
5. Never allow your hands or any other part of your body or clothing inside the feeding chamber, discharge chute or near any moving part while the engine is running.
6. Keep all guards and deflectors in place and in good working condition to assure continued safe operation.
7. Always stand clear of the discharge area when operating this machine.
8. Keep your face and body back from the feed opening to avoid accidental bounce back of any material.
9. Do not over-reach. Keep proper balance and footing at all times.
10. The engine governor settings on your machine must not be altered, changed, or tampered with. The governor controls the maximum safe operating speeds and protects the engine and all moving parts from damage caused by overspeed.
11. Do not transport machine while engine is running.
12. Do not operate engine if air cleaner or cover directly over carburetor air intake is removed, except for adjustment. Removal of such parts could create a fire hazard.

MAINTENANCE AND STORAGE

1. When this equipment is stopped for servicing, inspection, storage or to change an accessory, make sure the spark plug wire is disconnected from the spark plug. The machine should be allowed to cool down before making such inspection, adjustments, service, etc. Maintain your machine with care and keep it clean for the best and continued safe operation.
2. Do not use flammable solutions to clean the air filter.
3. When not in use, your machine should be stored out of the reach of children. Keep where gasoline fumes will not reach an open flame or spark. For long periods of storage, the gasoline should be drained and disposed in a safe manner. Always allow the machine to cool before storing in any enclosure.



This unit is shipped WITHOUT GASOLINE or OIL. After assembly, see operation section of this manual for proper fuel and engine oil recommendations.



The right and left side of your chipper-shredder is determined from behind the unit.

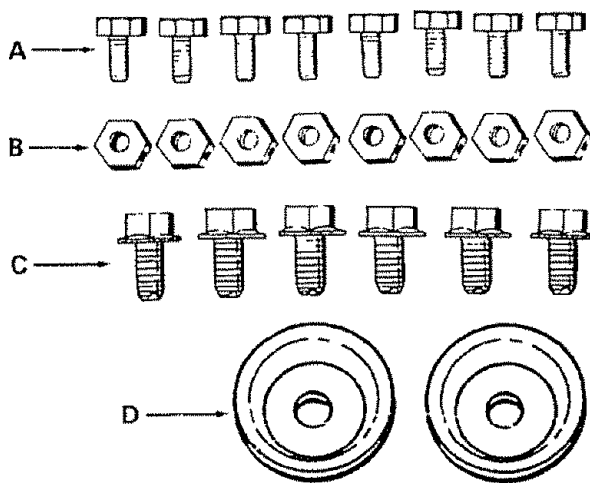

FIGURE 1.

ASSEMBLY INSTRUCTIONS

Tools Required for Assembly:

- (2) 7/16" Open End or Box Wrenches*
- (1) 1/2" Socket Wrench

* An Adjustable Wrench may be used in place of one of the wrenches.

UNPACKING

Remove the chipper-shredder and loose parts from the carton. Make certain all parts and literature have been removed before the carton is discarded.

Parts in Carton:

- Chipper-Shredder
- Chute Deflector
- Hopper
- Upper Leaf Ramp Section
- Catcher Bag
- Hardware Pack
- Safety Glasses

Contents of Hardware Pack (See Figure 1):

- A (8) Hex Bolts 1/4-20 x 1/2" Long
- B (8) Hex Lock Nuts 1/4-20 Thread
- C (6) Hex Washer Head Self-Tapping Screws
5/16-18 x 3/4" Long
- D (2) Keepers

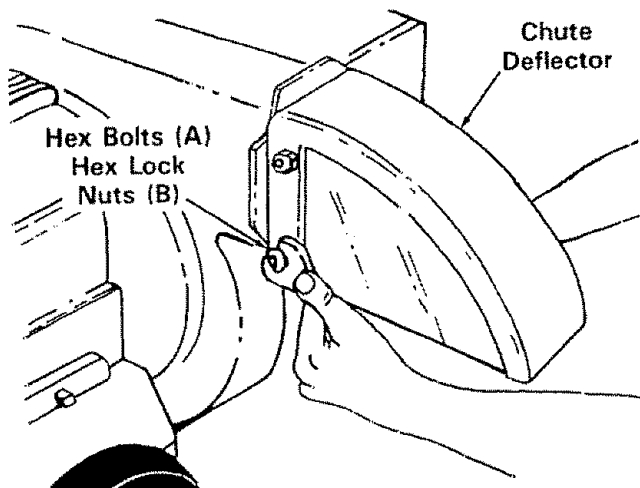

FIGURE 2.

CHUTE DEFLECTOR INSTALLATION

1. Place the chute deflector in position on the discharge opening (on the left side of the chipper-shredder). See figure 2
2. Secure chute deflector to discharge opening with hex bolts (A) and hex lock nuts (B). Heads of the hex bolts are inside the discharge opening. Hex nuts go on the outside
3. Tighten all four nuts and bolts securely

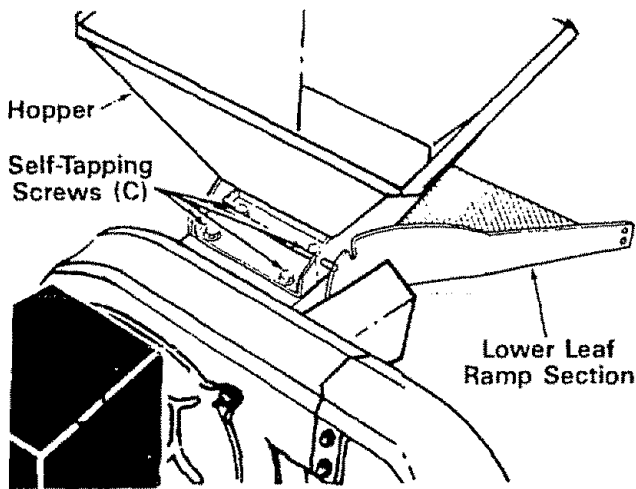

FIGURE 3.

INSTALLATION OF HOPPER AND UPPER GUIDE EXTENSION

1. The lower leaf ramp section on the chipper-shredder is placed in an upright position for shipping purposes. Lower this section.
2. Place the hopper in position on the shredder. See figure 3. Start all four hex washer head self-tapping screws (C), then tighten securely using a 1/2" socket wrench

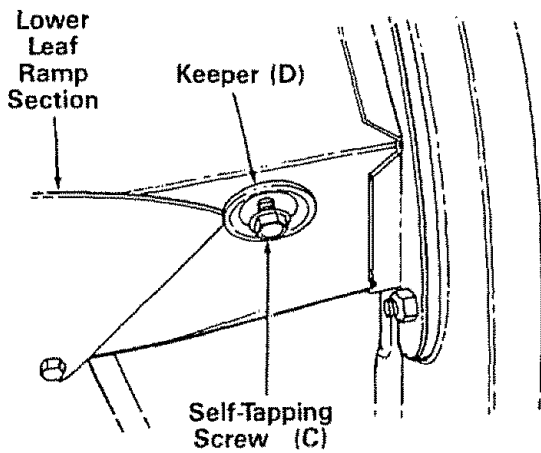

FIGURE 4.

3. Assemble the keepers (D) to the sides of the unit with two hex washer head self-tapping screws (C), using a 1/2" socket wrench. Tighten securely.

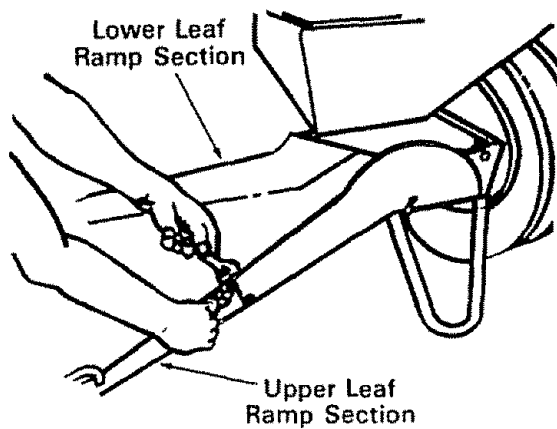

FIGURE 5.

4. Place upper leaf ramp section inside the lower leaf ramp section. Secure with four hex bolts (A) and hex lock nuts (B). Tighten securely. See figure 5.

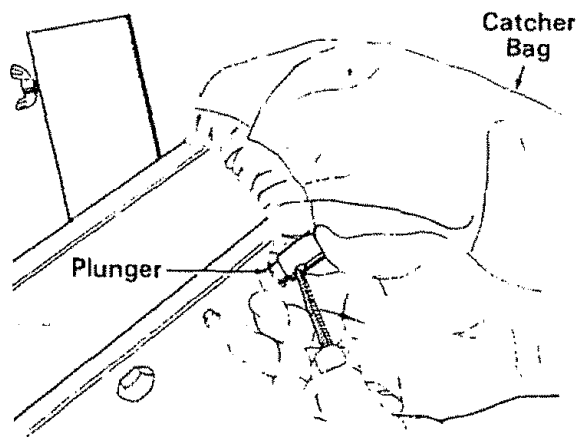

FIGURE 6.

ATTACHING THE CATCHER BAG

Your unit is equipped with a nylon bag which attaches to the discharge opening. If desired, place the end of the bag over the chute deflector. Depress plunger, pull on the drawstring, and release plunger to lock it in position. See figure 6.

OPERATION

GAS AND OIL FILL UP



ENGINE IS SHIPPED WITHOUT OIL. FILL CRANKCASE WITH OIL BEFORE STARTING. BE VERY CAREFUL NOT TO ALLOW DIRT TO ENTER THE ENGINE WHEN CHECKING OR ADDING OIL OR FUEL.

Recommended SAE Viscosity Grades

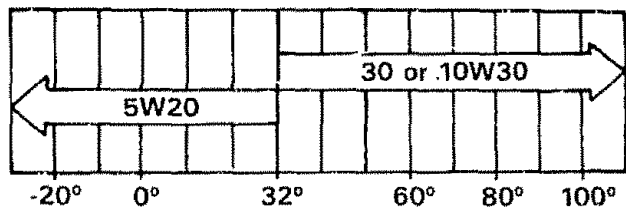

TEMPERATURE RANGE EXPECTED BEFORE NEXT OIL CHANGE. ALL OILS MUST A PI SERVICE CLASSIFICATION SD, SE OR SF.

1. Fill engine with oil.
 - a. Remove engine oil fill plug. See figure 7.
 - b. With chipper-shredder level, fill engine with oil to point of overflowing. Capacity is 1-1/4 pints.
 - c. Tilt chipper-shredder forward on its wheels, then re-level.
 - d. Check oil level. Refill to point of overflowing if necessary. Replace oil fill plug.

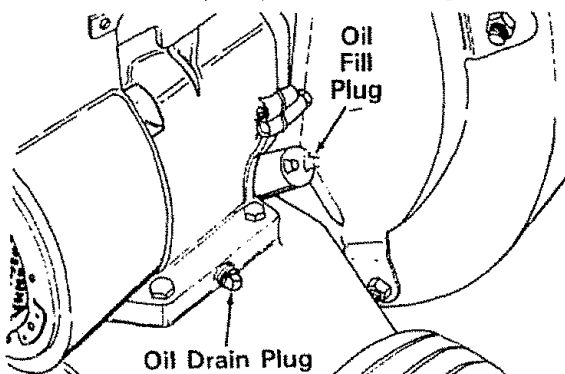

FIGURE 7.

2. Fill fuel tank. See figure 8. Use fresh, clean, unleaded automotive gasoline. Capacity is 3 quarts.

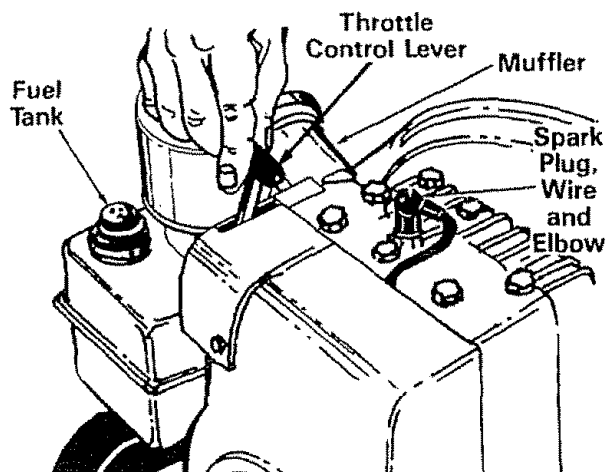

FIGURE 8.



WARNING

Fill to within 1/2 inch of top of fuel tank to prevent spills and to allow for fuel expansion. If gasoline is accidentally spilled, move chipper-shredder away from area of spill. Avoid creating any source of ignition until gasoline vapors have disappeared.



DO NOT USE GASOHOL OR METHANOL. These type fuels react with water content in the fuel and tend to form strong acids which can corrode metal parts and harm rubber plastics.

USE CLEAN OIL AND FUEL. STORE IN APPROVED, CLEAN, COVERED CONTAINERS. USE CLEAN FILL FUNNELS.

TO START ENGINE

1. Attach spark plug wire and boot to spark plug.
2. Place the throttle control lever in START position. See figure 8
3. Grasp starter handle (see figure 9) and pull rope out slowly until engine reaches start of compression cycle (rope will pull slightly harder at this point). Let the rope rewind slowly.

NOTE: A noise will be heard when finding the start of the compression cycle. This noise is caused by the flails and fingers which are part of the shredding mechanism falling into place, and should be expected.

4. Pull rope with a rapid, continuous, full arm stroke. Keep a firm grip on start handle. Let rope rewind slowly. Do not let starter handle snap back against starter.
5. Repeat preceding instructions 3 and 4 until engine fires.
6. After engine starts, move throttle control lever on engine to slow position for a few minutes warm up. Then move throttle control lever to RUN position for shredding-chipping operations.

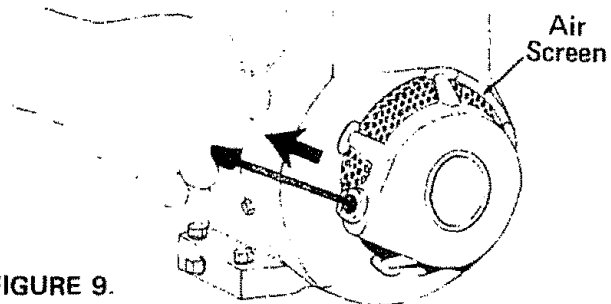

FIGURE 9.

TO STOP ENGINE

1. Move throttle control lever to STOP position. See figure 8.
2. Disconnect spark plug wire from spark plug and ground against the engine to prevent accidental starting while equipment is unattended.

HOW TO USE YOUR CHIPPER-SHREDDER

Your shredder is designed for safe, efficient operation. KEEP HANDS AND FEET AWAY FROM ALL OPENINGS.



Wear the safety glasses provided with your unit while operating the chipper-shredder to prevent injury from any chips which may be ejected out of the openings. Make certain chip-it guide is closed when not in use.

Wear gloves when handling material. Feed material into the chipper-shredder at a steady rate. It is possible to feed too fast. Experiment with feeding rates to determine what rate provides the best results without stalling the engine or plugging the discharge chute.

The discharge chute will direct the shredded material into a pile, a container or the bag provided with your shredder.



The chipper-shredder discharges material with considerable velocity. Keep away from the area around the discharge chute. Always stop the engine and disconnect the spark plug wire when removing or attaching the bag, when changing containers or when removing the shredded material.

If it becomes necessary to push materials into the chipper-shredder, use a small diameter stick, NOT YOUR HANDS. The stick should be small enough that it will be ground up if it gets into the impeller assembly.



Do not deposit material larger than 1.2" diameter in the hopper or upper guide extension. Any material heavier than 1/2" should be fed into the chip-it guide.

Leaves and smaller branches can be fed into the hopper with the leaf ramp raised as shown in figures 10 and 11.

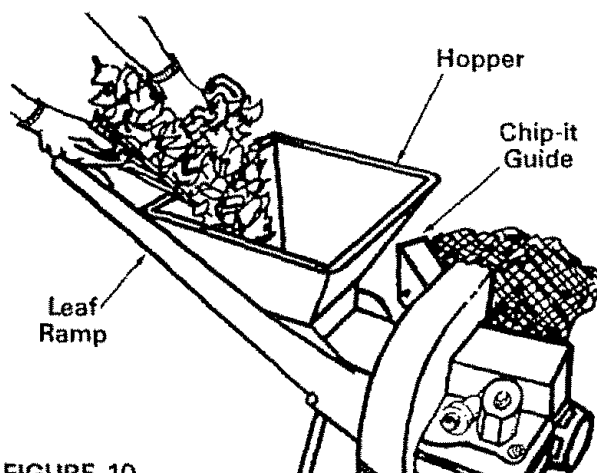

FIGURE 10.

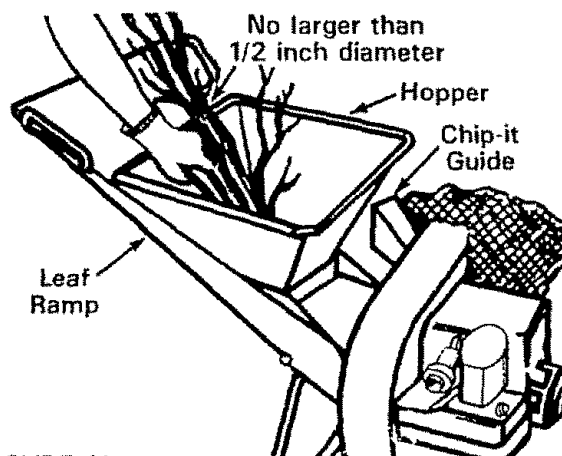

FIGURE 11.

Lower the leaf ramp by holding the handle and pulling up on the release bar. See figure 12. Leaves and small twigs can be raked into the chipper-shredder with the leaf ramp in this position. See figure 13.

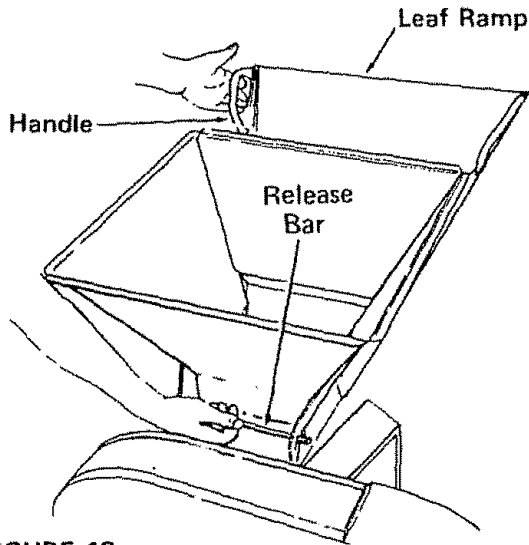

FIGURE 12.

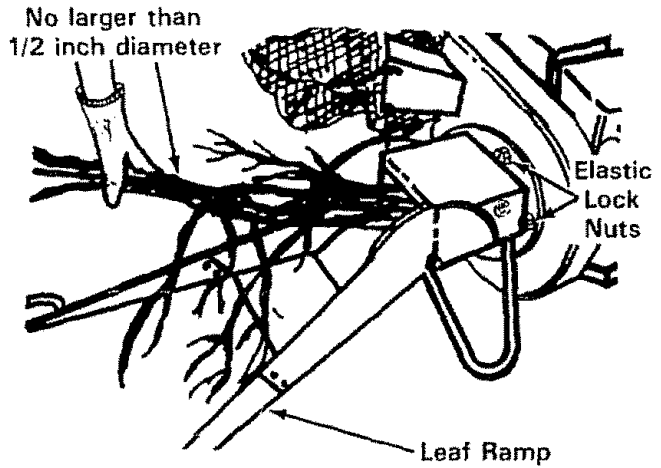

FIGURE 14.



Bulky material, such as stalks or heavy branches (anything over 1/2" diameter), should be fed into the chip-it guide. See figure 15. Do not force or jam material into the chip-it guide. Make certain leaf ramp is raised as shown in figure 15 when using the chip-it guide.



Make certain chip-it guide door is closed when not in use.

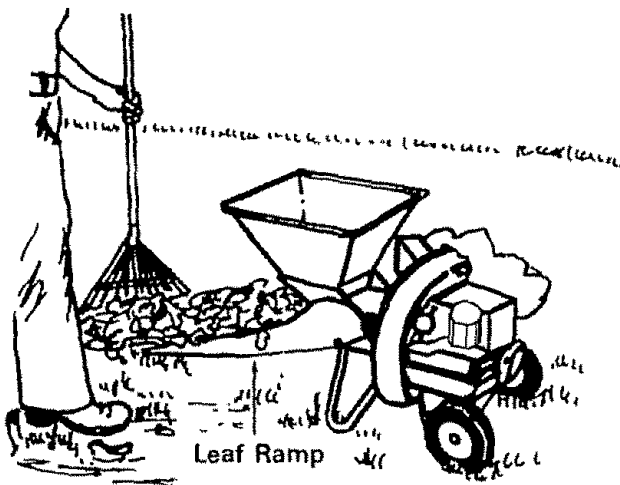

FIGURE 13.

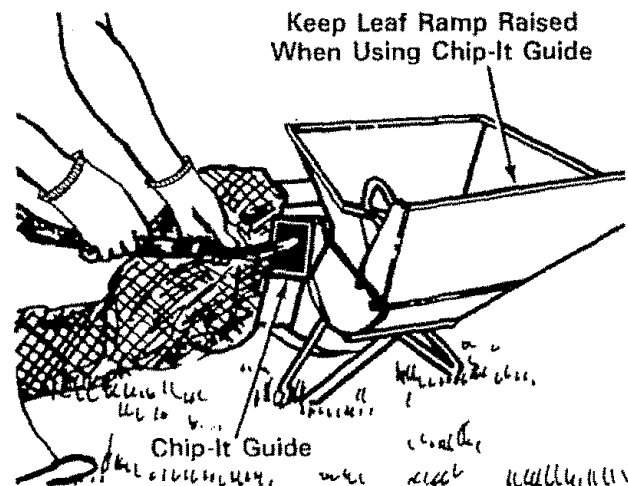

FIGURE 15.

Small branches can also be fed into the leaf ramp. See figure 14.

ADJUSTMENTS

CARBURETOR ADJUSTMENT



- If any adjustments are made to the engine while the engine is running (e.g. carburetor), keep clear of all moving parts. Be careful of heated surfaces and muffler.

Minor carburetor adjustment may be required to compensate for differences in fuel, temperature, altitude or load.



A DIRTY AIR CLEANER WILL CAUSE ENGINE TO RUN ROUGH. BE CERTAIN AIR CLEANER IS CLEAN AND ATTACHED TO THE CARBURETOR BEFORE ADJUSTING CARBURETOR. DO NOT MAKE UNNECESSARY ADJUSTMENTS. FACTORY SETTINGS ARE SATISFACTORY FOR MOST APPLICATIONS AND CONDITIONS.

Never attempt to change maximum engine speed. It is pre-set at the factory and should be changed only by a qualified service technician who has the necessary equipment.

The carburetor may need re-adjusting if engine lacks power or does not idle properly. If adjustments are needed, proceed as follows.

To Adjust Carburetor:

1. Close needle valve (See figure 16) clockwise (↻) finger tight only. Forcing may cause damage. Then open 1-1/2 turns counterclockwise (↺).
2. Start engine and allow to warm for five minutes.
3. With throttle in RUN position, close needle valve clockwise (↻) until engine starts to lose speed (lean mixture). Then slowly open needle valve counterclockwise (↺) until engine JUST BEGINS to run unevenly. This mixture should be rich enough for best performance under load.
4. Place throttle control in IDLE position:
 - a. If engine idles, no further adjustment is necessary.
 - b. If engine idles too fast, turn idle speed adjusting screw counterclockwise (↺) until slower speed is obtained.
 - c. If engine dies, turn idle speed adjusting screw 1/4 turn clockwise (↻). Place throttle control in FAST position and restart engine.
 - d. Move throttle control to IDLE position. If engine does not idle, repeat step c.

5. Test the engine by operating the chipper-shredder. If engine tends to stall or die out, it usually indicates that the mixture is slightly lean and it may be necessary to open (↺) the needle valve slightly to provide a richer mixture. This richer mixture may cause a slight unevenness in idling.

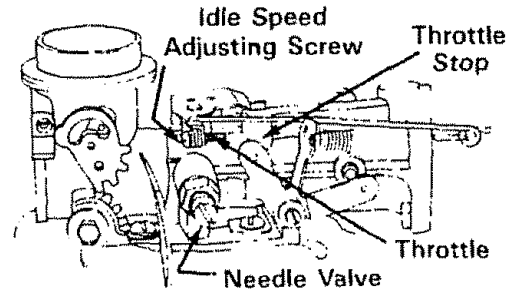

FIGURE 16.

MAINTENANCE



Disconnect spark plug wire and ground it against the engine before performing any repairs or maintenance.

ENGINE LUBRICATION

Your four cycle engine will normally consume some oil; therefore check engine oil level regularly - approximately every five hours of operation and before each usage. Stop engine and wait several minutes before checking oil level. With engine level, the oil must be even with the oil fill (refer to figure 7). Change engine oil after the first two hours of operation, and every twenty-five hours thereafter.

1. Drain oil while engine is warm
 - a. Remove oil drain plug. Refer to figure 7.
 - b. Tip the chipper-shredder forward, and catch oil in a suitable container.
 - c. When engine is drained of all oil, replace drain plug securely.
2. Refill with fresh oil. Above 32°, use oil labeled SAE 30W or 10W30. Below 32°, use oil labeled 5W20. Capacity is 1-1/4 pints. Refer to "Gas and Oil Fill-Up" on page 6.
3. Replace oil fill plug.

AIR CLEANER

The air cleaner prevents damaging dirt, dust, etc., from entering the carburetor and being forced into the engine and is important to engine life and performance.

Never run your engine without air cleaner completely assembled.

To Service Air Cleaner:

Clean and re-oil foam pre-cleaner at three month intervals or every 25 hours, whichever occurs first. See figure 17. Service more often under dusty conditions.

1. Remove knob and cover.
2. Remove foam pre-cleaner by sliding it off the paper cartridge.
 - a. Wash foam pre-cleaner in liquid detergent and water.
 - b. Wrap foam pre-cleaner in cloth and squeeze dry.
 - c. **Saturate foam pre-cleaner in clean engine oil.** Squeeze to remove excess oil.
3. Install foam pre-cleaner over paper cartridge. Reassemble cover and screw down tight.

Replace and clean cartridge included with dual element air cleaner yearly or every 100 hours. Service more often if necessary.

Clean cartridge by tapping gently on a flat surface. If very dirty, replace cartridge or clean as follows:

- a. Wash in a low or non-sudsing detergent and warm water solution. **CAUTION:** Do not use petroleum solvents such as kerosene, to clean cartridge.
 - b. Rinse thoroughly with flowing water from inside out until water is clear.
 - c. Allow cartridge to stand and air dry thoroughly before using. **DO NOT OIL CARTRIDGE. DO NOT USE PRESSURIZED AIR TO CLEAN OR DRY CARTRIDGE**
4. Install cartridge and pre-cleaner then the cover. Screw knob down securely.

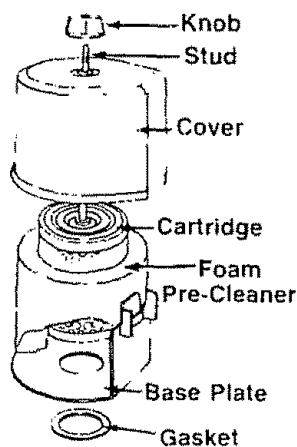

FIGURE 17.

MUFFLER

Do not operate the chipper-shredder without a muffler or tamper with the exhaust system. Damaged mufflers or spark arresters could create a fire hazard. Inspect periodically, and replace if necessary. If your engine is equipped with a spark arrester screen assembly, remove every 50 hours for cleaning and inspection. Replace if damaged.

CLEAN ENGINE

Clean engine periodically. Remove dirt and debris with a cloth or brush. Cleaning with a forceful spray of water is not recommended as water could contaminate the fuel system.

Yearly or every 50 hours, whichever occurs first, remove the blower housing and clean the areas shown in figure 18 to avoid overspeeding, overheating and engine damage. Clean more often if necessary.



Periodically clean muffler area to remove all grass, dirt and combustible debris.

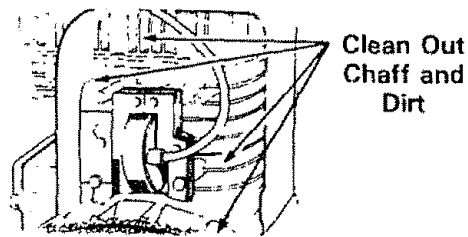

FIGURE 18.

SPARK PLUG

The spark plug should be cleaned and the gap reset to .030" at least once a season or every 50 hours of operation. Spark plug replacement is recommended at the start of each season. Refer to engine parts list for correct spark plug type.

NOTE: Do not blast clean spark plug. Spark plug should be cleaned by scraping or wire brushing and washing with a commercial solvent.

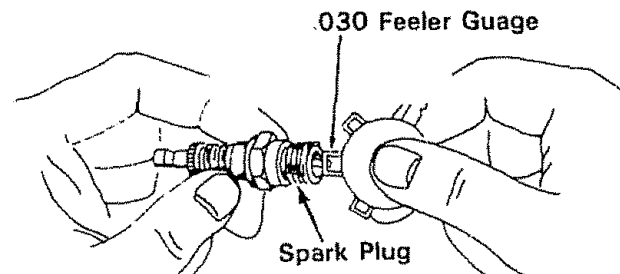

FIGURE 19.

LUBRICATION

Wheels - The wheels require no lubrication.

Flails and Fingers - If the unit is disassembled for any reason, lubricate the flails and fingers with a light oil (engine oil may be used)

CUTTING BLADE

The cutting blade may be removed for grinding or replacement as follows

1. Lower the upper guide extension
2. Block up the housing. See figure 20.
3. Remove the four elastic lock nuts from the back of the housing using a 1/2" wrench. Refer to figure 14. Separate the shredder into two halves.
4. Remove the back-up plate. See figure 20



When reassembling, make certain the opening on the back up plate is toward the bottom of the unit. The back up plate may be reversed to provide a new cutting edge.

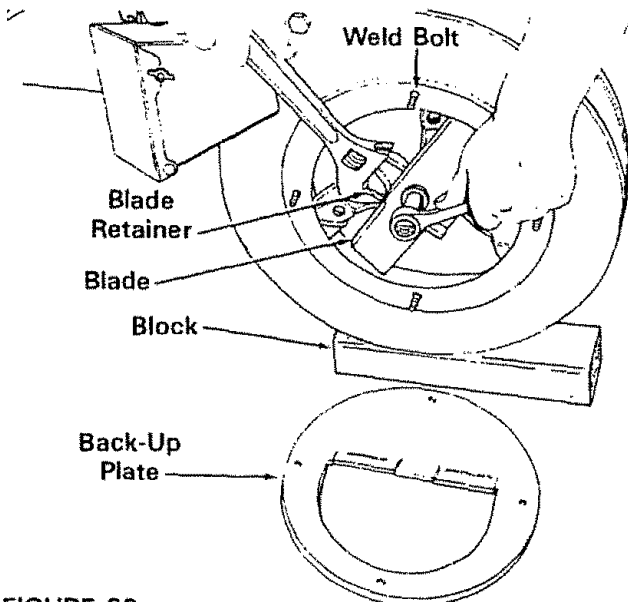

FIGURE 20.

5. Hold the blade retainer on the impeller assembly with an adjustable wrench to keep the blade from turning as shown in figure 20.
6. Remove the blade by removing the center bolt, lock washer and flat washer.



Use caution when removing the blade to avoid contacting the weld bolts protruding from the housing.



The blade is reversible and can be assembled to the crankshaft with either side showing

When sharpening the blade, follow the original angle of grind as a guide. It is extremely important that each cutting edge receives an equal amount of grinding to prevent an unbalanced blade. An unbalanced blade will cause excessive vibration when rotating at high speeds and may cause damage to the unit.

The blade can be tested by balancing it on a round shaft screwdriver or nail. Remove metal from the heavy side until it balanced evenly. See figure 21.

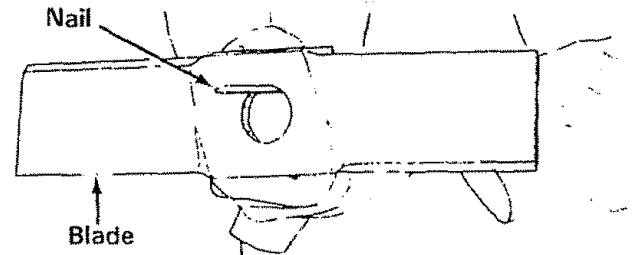

FIGURE 21.

When reassembling the blade, tighten to between 375 and 450 inch pounds, or lacking torque wrench, tighten securely.

FLAILS AND FINGERS

The flails and fingers may be reversed when they become dull. It is suggested that this procedure be performed by your nearest Sears Service Department.

OFF-SEASON STORAGE

If the chipper-shredder is to be inoperative for a period longer than 30 days, the following precautions are recommended.

1. Working outdoors, drain all fuel from the fuel tank. Run the engine until it stops from lack of fuel.



DO NOT DRAIN FUEL WHILE SMOKING, OR IF NEAR AN OPEN FIRE.

2. Drain all the oil from the crankcase (this should be done after the engine has been operated and is still warm) and refill crankcase with fresh oil.
3. Protect the inside of the engine for storage as follows:
Remove spark plug, pour approximately 1/2 ounce (approximately one tablespoon) of engine oil into cylinder and crank slowly to distribute oil. Replace spark plug.
4. Clean the engine and the entire chipper-shredder thoroughly.



When storing any type of power equipment in an unventilated or metal storage shed, care should be taken to rustproof the equipment. Using a light oil or silicone, coat the equipment, especially all moving parts.

5. Store in a clean, dry area.

MAINTENANCE CHECK LIST

SERVICE RECORD FILL IN DATES AS YOU COMPLETE REGULAR SERVICE	Page No.	1st 2 Hours	Frequently	Every 5 Hours	Every 25 Hours	Every 50 Hours	SERVICE DATES														
Check Engine Oil Level	9		✓																		
Change Engine Oil	9	✓			✓																
Clean Engine	10		✓																		
Service Air Cleaner	10				✓																
Clean Engine Cylinder Fins	10					✓															
Clean or Replace Spark Plug	10					✓															

TROUBLE SHOOTING CHART

SYMPTON	POSSIBLE CAUSE(S)	SOLUTION
Engine fails to start	<ol style="list-style-type: none"> 1. Check fuel tank for gas. 2. Spark plug lead wire disconnected 3. Faulty spark plug 	<ol style="list-style-type: none"> 1. Fill tank if empty (p. 6). 2. Connect lead wire (p. 6). 3. Clean, adjust gap or replace (p. 10).
Hard starting or loss of power	<ol style="list-style-type: none"> 1. Spark plug wire loose. 2. Dirty air cleaner. 	<ol style="list-style-type: none"> 1. Connect and tighten spark plug wire (p. 6). 2. Clean air cleaner as described in maintenance section (p. 10).
Engine overheats	<ol style="list-style-type: none"> 1. Carburetor not adjusted properly 2. Air flow restricted. 3. Engine oil level low 	<ol style="list-style-type: none"> 1. Adjust carburetor. See adjustment section (p. 9). 2. Remove blower housing and clean as described in the maintenance section (p. 10). 3. Fill crankcase with the proper oil (p. 6).
Material not shredding	Blade and/or flails not sharp.	Sharpen or reverse blade and flails (p. 11)
Engine bogs down or stalls	<ol style="list-style-type: none"> 1. No fuel in fuel tank. 2. Feeding material into the machine too quickly. 	<ol style="list-style-type: none"> 1. Fill tank if empty (p. 6). 2. Do not force material into the opening. Feed gradually (p. 7).

NOTE: For repairs beyond the minor adjustments listed above, please contact your Sears Authorized Service Center.



Repair Parts

5 H.P. Chipper-Shredder—Model 247.796890

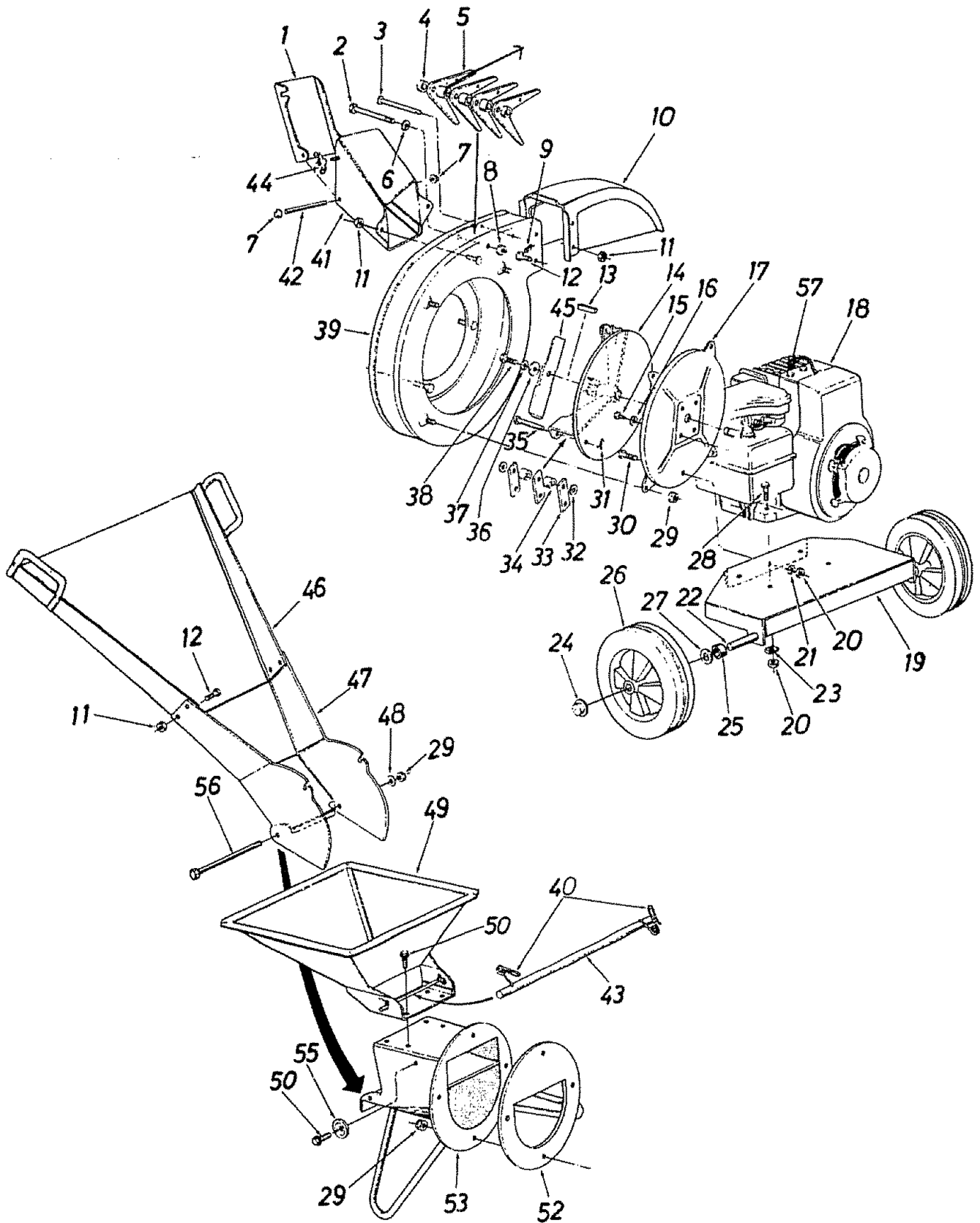

Repair Parts

5.H.P. Chipper-Shredder—Model 247.796890

Key No.	Part No.	Description	Key No.	Part No.	Description
1	11476	Door Chip It	31	714-0144	Cotter Pin 1/8" Dia x 1.00" Lg* (Special)
2	710-0465	Hex Bolt 1/2-20 x 4.50" Lg.*	32	736-0192	Fl-Wash. 531" I.D. x 937 O.D. x .09
3	711-0580	Clevis Pin	33	11459	Flail
4	711-0579	Flail Spacer 7/32" Lg.	34	711-0564	Flail Spacer 23/32" Lg.
5	11455	Cutting Finger	35	711-0578	Clevis Pin .50" Dia. x 3.0" Lg.
6	736-0921	L-Wash 1/2" I.D.*	36	736-0247	Fl-Wash. 406" I.D. x 1.25" O.D. Hdn.
7	726-0111	Palnut 3/16" Dia.	37	736-0217	L-Wash. 3/8" I.D. H.D.
8	712-0922	Hex Jam Nut 1/2-20 Thd.*	38	710-0151	Hex Bolt 3/8-24 x 2.0" Lg HT
9	714-0507	Cotter Pin 3/32" Dia. x 3/4" Lg.*	39	14575--629	Flail Housing Ass'y-Comp.
10	16568	Chute Deflector	40	732-0546	Torsion Spring .062 Dia. x 1.06 Lg.
11	712-0107	L-Nut 1/4-20 Thd.	41	11477	Chip-It Guide Ass'y.
12	710-0289	Hex Bolt 1/4-20 x .50" Lg.*	42	11478	Hinge Pin
13	714-0114	Sq. Key 1/4" x 2.00" Lg.	43	747-0531	Release Bar
14	13430	Impeller Assembly	44	712-0109	Wing Nut Elastic 1/4-20 Thd.
15	710-0157	Hex Bolt 5/16-24 x 3/4" Lg.*	45	13431	Blade
16	736-0119	L-Wash. 5/16" I.D.*	46	11460--629	Upper Leaf Ramp Section
17	14573	Hopper to Engine Mtg. Plate	47	16524--629	Lower Leaf Ramp Section
18	5 H.P.	Engine - B & S 130212-1731-01	48	736-0264	Fl-Wash. 5/16" I.D.
19	11464	Engine Mounting Plate	49	11481--629	Hopper Assembly
20	712-0123	Hex Nut 5/16-24 Thd.*	50	710-0601	Hex Wash. Hd. Self-Tap Scr. 5/16-18 x .75" Lg
21	736-0119	L-Wash. 5/16" I.D.*	52	11454	Back-Up Plate
22	738-0521	Shaft	53	16522	Inlet Guide Assembly
23	736-0170	Special L-Wash. 5/16" I.D.	55	11480	Stop Washer
24	726-0221	Push Cap	56	710-0542	Hex Bolt 5/16-18 x 8.38" Lg
25	711-0494	Spacer	57	735-0639	Spark Plug Elbow
26	734-1173	Wheel Ass'y-Comp.	---	764-0199	Bag (Not Shown)
27	736-0100	Fl-Wash. 50" I.D.	---	723-0400	Safety Glasses (Not Shown)
28	710-0624	Hex Bolt 5/16-24 x 1.50" Lg.*			
29	712-0429	Elastic Lock Nut 5/16-18 Thd			
30	710-0237	Hex Bolt 5/16-24 x .62" Lg.*			

* Common Hardware - May be purchased locally.

NOTE: Specifications subject to change without notice or obligation.

Repair Parts

5 H.P. Chipper-Shredder—Model 247.796890

Engine—Model 130212 Type 1731-01

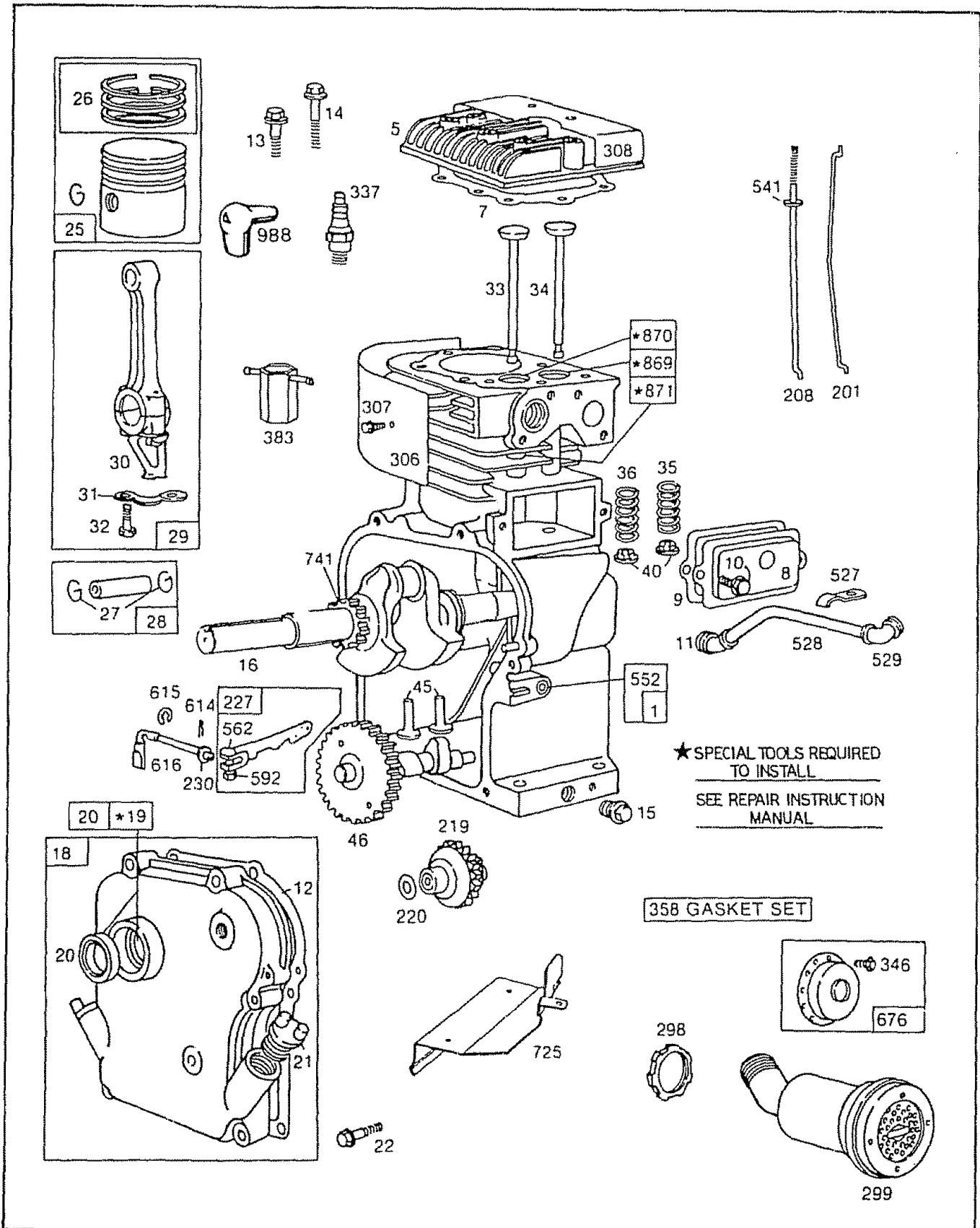

Repair Parts

5 H.P. Chipper-Shredder—Model 247.796890

Engine—Model 130212 Type 1731-01

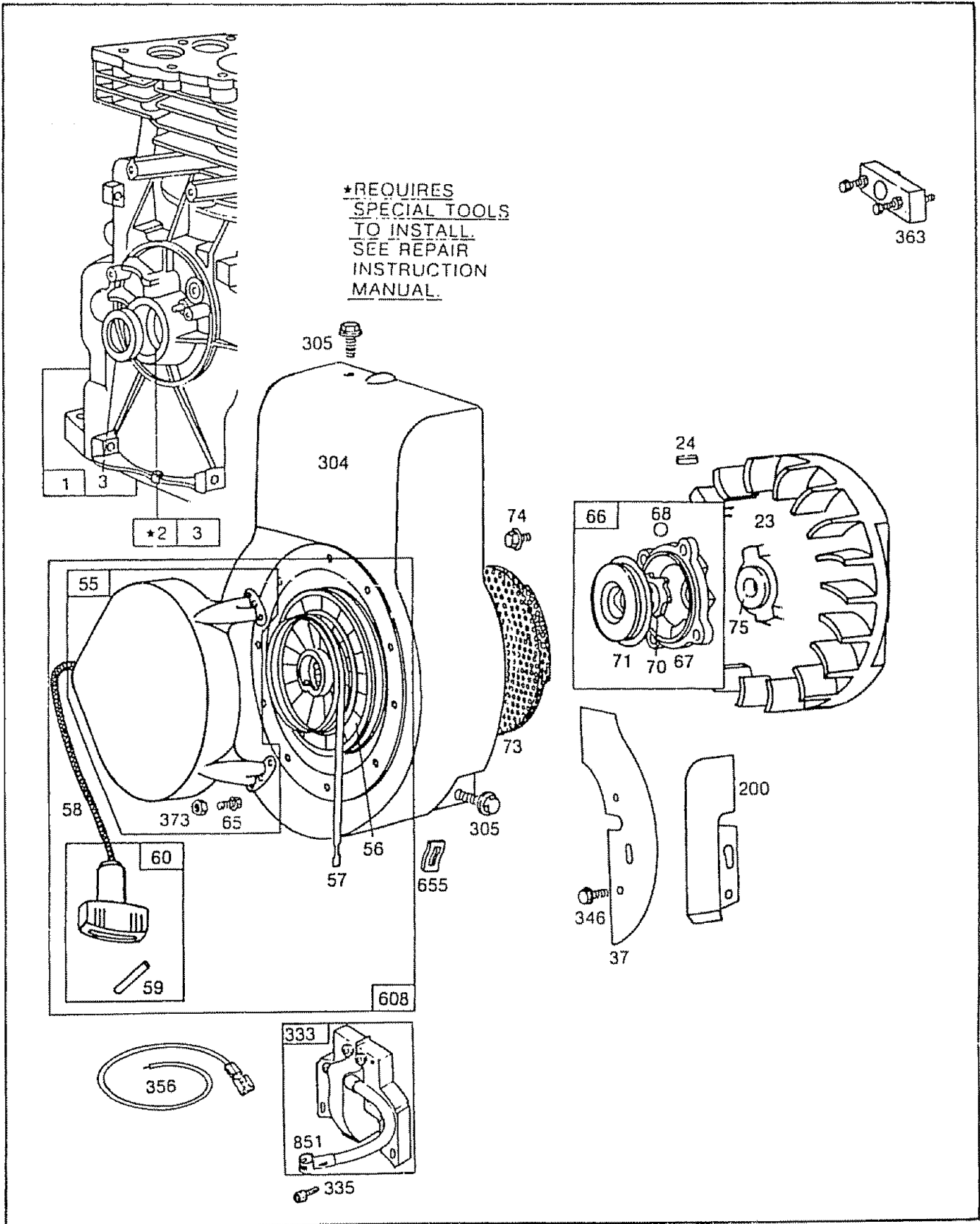

Repair Parts

5 H.P. Chipper-Shredder—Model 247.796890

Engine—Model 130212 Type 1731-01

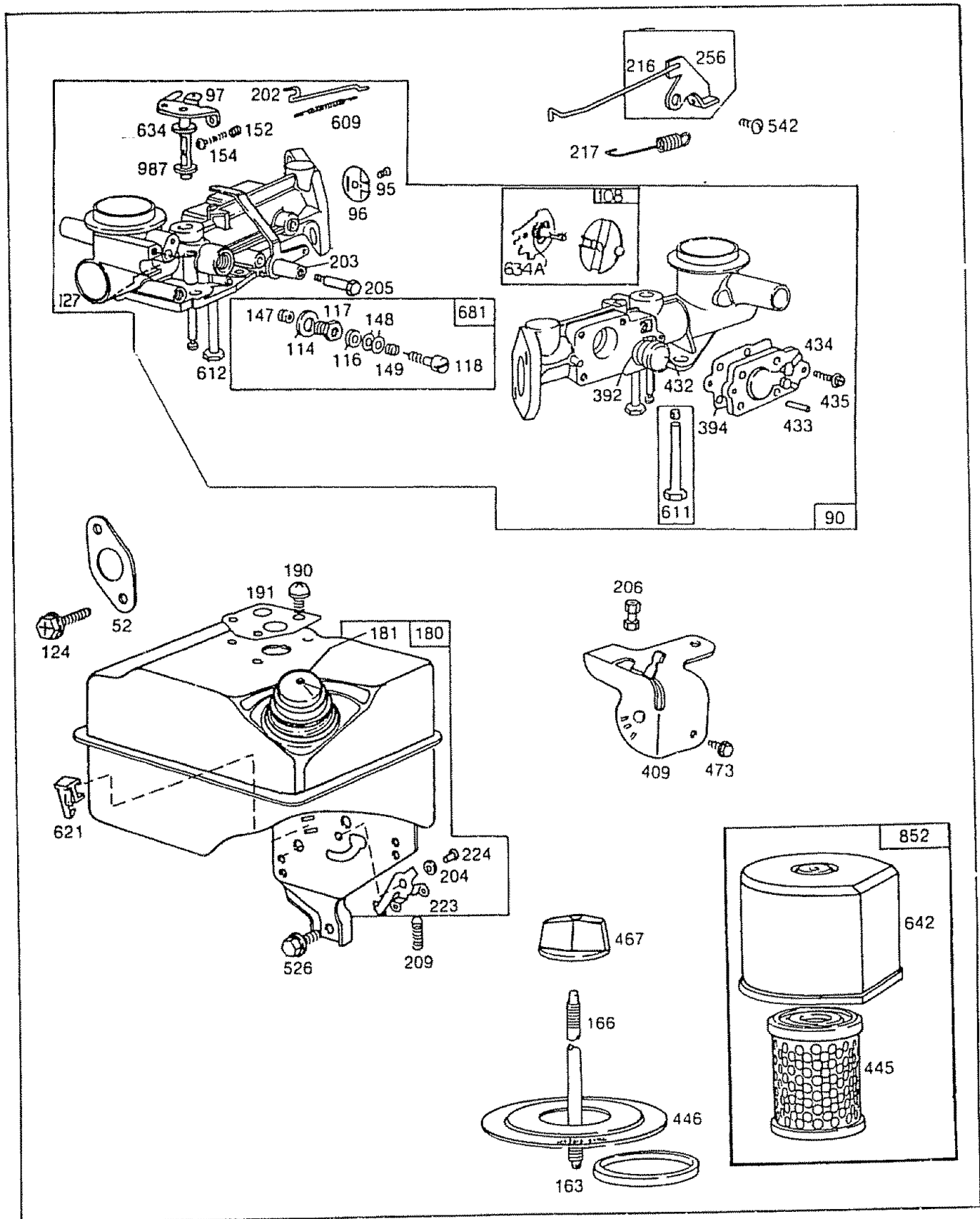

Repair Parts

5 H.P. Chipper-Shredder—Model 247.796890

Engine—Model 130212 Type 1731-01

KEY NO	PART NO	DESCRIPTION	KEY NO	PART NO	DESCRIPTION
1	395990	Cylinder Assembly	31	221876	Lock—Screw Head
2	297565	Bushing—Cylinder	32	92296	Screw—Connecting Rod
	Note:	Requires special tools for installation	33	211119	Valve—Exhaust
3	299819	Seal—Oil	34	261044	Valve—Intake
5	211542	Head—Cylinder	35	260552	Spring—Intake Valve
7	*270383	Gasket—Cylinder Head	36	26478	Spring—Exhaust Valve
8	294178	Breather—Valve Chamber	37	222443	Guard—Flywheel
9	*27549	Gasket—Valve Cover	40	93312	Retainer—Valve Spring
10	93394	Screw—Breather Mtg. Sem	45	260642	Tappet—Valve
11	66578	Grommet—Breather Tube	46	212733	Gear—Cam
12	*270080	Gasket—Crankcase— .015 thick (Standard)	52	*27355	Gasket—Carburetor Mounting (2)
	*270125	Gasket—Crankcase— .005" thick	55	299431	Housing—Rewind Starter
	*270126	Gasket—Crankcase— .009" thick	56	295871	Pulley—Rewind Starter (Includes 63" long rope)
13	93368	Screw—Cylinder Head (2-3/32" long)	57	294303	Spring—Rewind Starter
14	93369	Screw—Cylinder Head (2-15/32" long)	58	66884	Rope—Rewind Starter— 63" long
15	91249	Plug—Pipe, 1/4" Std. Square Head	59	230228	Pin—Starter Grip
		To Replace Crankshaft Gear Pin, Order Part No. 230978	60	393152	Grip—Starter Rope
16	398098	Crankshaft	65	93105	Screw—Standard Steel Housing Mtg. Sem
18	298517	Cover Assy.—Crankcase	66	399671	Clutch Assy.—Rewind Starter
19	297603	Bushing—Crankcase Cover	67	394897	Housing—Starter Clutch
		Note: Requires special tools for installation.	68	63770	Ball—Clutch
20	298504	Oil Seal and Spacer	70	298436	Ratchet—Rewind Starter
21	66768	Plug—Oil Filler	71	394506	Washer—Clutch Retainer
22	93032	Screw—Crankcase Cover Mounting Sem	73	221923	Screen—Starter Pulley
23	297229	Flywheel—Magneto	74	93490	Screw—Sem
24	222698	Key—Flywheel	75	220865	Washer—Spring
25	298904	Piston Assy— Standard	90	397940	Carb. Assy
	298905	Piston Assy.—.010" O.S.	95	93499	Screw—Throttle Valve to Shaft Sem
	298906	Piston Assy.—.020" O.S.	96	211203	Throttle—Carburetor
	298907	Piston Assy.—.030" O.D.	97	299212	Shaft and Lever— Throttle
PISTON RING SETS:			108	397134	Valve Group—Choke
		Note: For Chrome Piston Ring Set — Standard Size — Order Part No. 299742.	114	66594	Gasket—Needle Valve Nut
26	298982	Ring Set—Standard Piston	116	65978	Packing—Needle Valve
	298983	Ring Set—.010" O.S. Piston	117	230590	Nut—Needle Valve
	298984	Ring Set—.020" O.S. Piston	118	23433	Valve—Needle
	298985	Ring Set—.030" O.S. Piston	124	93357	Screw—Hex Head
27	26026	Lock—Piston Pin	127	22831	Plug—Welch
28	298909	Pin Assy.—Piston— Standard	147	230591	Seat—Needle Valve
	298908	Pin Assy.—Piston—.005" O.S.	148	22235	Washer—Needle Valve (2)
29	299430	Rod Assy.—Connecting	149	26336	Spring—Needle Valve
		Note: For Connecting Rod with .020" undersize Crankpin Bore— Order No. 390459.	152	260575	Spring—Throttle Adjustment
30	221980	Dipper—Connecting Rod	154	93527	Screw—Machine, Rd. Hd.— 5-40 x 5/8"
			163	271139	Gasket—Air Cleaner Mounting
			166	231332	Stud—Air Cleaner
			180	397137	Tank Assembly—Fuel
			181	394818	Cap—Fuel Tank
			190	93440	Screw—Fuel Tank Mounting Sem (2)
					Note: 94094 Screw—Fuel Tank Mounting (1)



Repair Parts

5 H.P. Chipper-Shredder—Model 247.796890
 Engine—Model 130212 Type 1731-01

KEY NO.	PART NO.	DESCRIPTION	KEY NO.	PART NO.	DESCRIPTION
191	*271592	Gasket—Fuel Tank Mounting	435	93141	Screw—Diaphragm Cover
200	221480	Guide—Air	445	396424	Cartridge—Air Cleaner
201	261558	Link—Governor		271466	Foam Pre-Cleaner Element (not shown)
202	260678	Link—Throttle			
203	393919	Crank—Bell	446	222844	base -Air Cleaner
204	222962	Bushing—Governor Lever (Flat)	467	212706	Knob Air Cleaner
205	93838	Screw—Shoulder	473	93612	Screw Sem
206	280012	Nut—Control Rod	526	93343	Screw Tank Bracket Mounting Sem
208	230946	Rod—Control			
209	260695	Spring—Governor	527	221514	Clamp Breather Tube
216	397709	Link—Choke (Includes Bell Crank)	528	231386	Tube Breather
217	261951	Spring—Choke	529	67838	Grommet Breather Tube
219	391737	Gear—Governor	541	22398	Washer
220	221551	Washer—Thrust	542	94025	Screw
223	221517	Lever—Governor Control	552	231079	Bushing Governor Crank (1/4" I.D.)
224	93491	Rivet—Governor Control Lever Mounting	562	92613	Bolt Governor Lever
227	393920	Lever Assy—Governor	592	231082	Nut Hex 10 24
230	222450	Washer—Governor Lever	608	390463	Starter Assy Rewind
256	397709	Crank—Bell (Includes Choke Link)	609	260294	Spring Throttle Link
298	261409	Locknut—Muffler	611	391813	Fuel Pipe and Clip Assembly
299	393368	Muffler—Exhaust	612	296811	Pipe—Fuel
304	299410	Housing—Blower	614	93306	Cotter Hair Pin
305	93158	Screw—Blower Housing Mounting	615	93307	Retainer E-Ring
306	221511	Shield—Cylinder	616	231077	Crank Governor (1/4" Dia)
307	93042	Screw—Cylinder Shield Mounting Sem	621	297472	Switch -Stop
308	221512	Cover—Cylinder Head	634	271853	Washer Throttle Shaft (Foam)
333	397358	Armature Assembly	634A	270382	Washer Choke Shaft
335	93414	Screw—Armature Mtg. Sem	642	223306	Cover Air Cleaner
337	298809	Plug—Spark 1-1/2" High— 37-42 M.M.	655	222598	Anchor Spring
346	93705	Screw—Sem	676	395700	Deflector Exhaust (Direct Outlet)
356	398808	Wire—Ground	681	299060	Needle Valve Kit
358	397145	Gasket Set	725	223334	Shield - Heat
363	19069	Flywheel Puller (Optional Accessory)	741	261696	Gear Timing
373	93987	Nut—Hex	851	221798	Cable Terminal--Ignition
383	89838	Wrench—Spark Plug	852	396397	Cleaner Group - Air
392	260455	Spring—Fuel Pump Diaphragm	869	211787	Seat - Intake Valve (Standard)
394	270026	Diaphragm	870	211172	Seat -Exhaust Valve (Standard)
409	299837	Lever-Trol—Speed Control	871	231348	Note: For Options see Repair Manual.
432	221377	Cap—Spring			Guide Exhaust Valve
433	93265	Pin—Diaphragm Cover			Note: 63709 Guide - Intake Valve
434	210959	Cover—Diaphragm	987	398970	See Repair Instruction Manual.
			988	735-0639	Seal Throttle Shaft
					Spark Plug Elbow

*Included in Gasket Set
 Part No. 397145.

<p>SPARK ARRESTING MUFFLER ASSEMBLY 392390 (Optional Equipment)</p> <p>Consists of the following:</p> <p>392154 Screen (1 required)</p> <p>223372 Deflector (1 required)</p> <p>93705 Screw (4 required)</p>
--



SEARS

OWNERS
MANUAL

MODEL NO.
247.796890

HOW TO ORDER
REPAIR PARTS

SEARS / CRAFTSMAN®

5 H.P.
CHIPPER-SHREDDER

The model number will be found on the model plate, attached to the frame. Always mention the model number when requesting service or repair parts for your chipper-shredder

All parts listed herein may be ordered from any Sears Service Center and most Sears stores

WHEN ORDERING REPAIR PARTS, ALWAYS GIVE THE FOLLOWING INFORMATION:

- THE PART NUMBER
- THE PART DESCRIPTION
- THE MODEL NUMBER 247 796890
- THE NAME OF MERCHANDISE—CHIPPER-SHREDDER

If the parts you need are not stocked locally, your order will be electronically transmitted to a Sears Repair Parts Distribution Center for handling

Sears, Roebuck and Co., Chicago, Ill 60684 U.S.A.