

Sunbeam

Copper Infused DuraCeramic™ Air Fryer

User Guide

AFP4000WH
AFP4000BK



Contents

Sunbeam's Safety Precautions	1
Features Of Your Sunbeam Air Fry	2
Copper Infused Duraceramic™ Bowl	3
Guide To Fats & Oils	4
Cooking Guide	5
Cooking Popular, Convenience And Frozen Foods	6
Care & Cleaning	7
Troubleshooting	8

Important instructions – retain for future use.

تأكد من تفهم احتياطات السلامة المذكورة اعلاه

請務必理解上述的安全預防措施。

Assurez-vous que les précautions ci-dessus relatives à la sécurité sont bien comprises

Versichern Sie sich, dass die obenstehenden Sicherheitsmaßnahmen Verstanden werden

Βεβαιώσετε πως οι παραπάνω προφυλάξεις ασφαλείας γίνονται κατανοητές

Pastikan bahwa tindakan-tindakan keselamatan seperti di atas dimengerti anda

Accertatevi che le suddette norme di sicurezza siano comprese a dovere

上記の注意事項をよくお読みになり、安全を御確認ください

Уверете се дека погоре споменатите мерки на претпазливост се добро разбрани

Asegúrese de que las precauciones de seguridad precedentes sean bien comprendidas

کاری بکنید کہ احتیاط‌های بالا حتماً درک بشوند

ต้องแน่ใจว่า ข้อควรระวังเรื่องความปลอดภัยข้างต้น เป็นที่เข้าใจกันดี

Yukarda belirtilen güvenlik önlemlerinin anlaşıldığından emin olunuz

Xin kiểm chắc rằng những biện pháp làm an toàn kể trên được hiểu rõ

Sunbeam's Safety Precautions

Sunbeam is very safety conscious when designing and manufacturing consumer products, but it is essential that the product user also exercise care when using an electrical appliance. Listed below are precautions which are essential for the safe use of an electrical appliance:

- Read carefully and save all the instructions provided with the appliance.
- Always turn the power off at the power outlet before you insert or remove a plug. Remove by grasping the plug - do not pull on the cord.
- Turn the power off and remove the plug when the appliance is not in use and before cleaning.
- Do not use your appliance with an extension cord unless this cord has been checked and tested by a qualified technician or service person.
- Always use your appliance from a power outlet of the voltage (A.C. only) marked on the appliance.
- Children should be supervised to ensure that they do not play with the appliance.
- The temperature of accessible surfaces may be high when the appliance is operating.
- Never leave an appliance unattended while in use.
- Do not use an appliance for any purpose other than its intended use.
- Do not place an appliance on or near a hot gas flame, electric element or on a heated oven.
- Do not place on top of any other appliance.
- Do not let the power cord of an appliance hang over the edge of a table or bench top or touch any hot surface.
- Do not operate any electrical appliance with a damaged cord or after the appliance has been damaged in any manner. If damage is suspected, return the appliance to the nearest Sunbeam Appointed Service Centre for examination, repair or adjustment.
- For additional protection, Sunbeam recommend the use of a residual current device (RCD) with a tripping current not exceeding 30mA in the electrical circuit supplying power to your appliances.
- Do not immerse the appliance in water or any other liquid unless recommended.
- Appliances are not intended to be operated by means of an external timer or separate remote control system.
- This appliance is intended to be used in household and similar applications such as: staff kitchen areas in shops, offices and other working environments; farm houses; by clients in hotels, motels and other residential type environments; bed and breakfast type environments.
- Refer to "Care and Cleaning" section for details concerning precautions during use maintenance.
- Cleaning and user maintenance shall not be made by children unless they are older than 8 and supervised.
- Keep the appliance and its cord out of reach of children less than 8 years old.
- This appliance is not intended for use by persons (including children) with reduced physical, sensory or mental capabilities, or lack of experience and knowledge, unless they have been given supervision or instruction concerning use of the appliance by a person responsible for their safety.
- Keep appliance 20cm away from the wall when in use.



**Hot Surface
Do Not Touch**

This symbol indicates, temperature of accessible surfaces may be high when the appliance is operating and for some time after use.

If you have any concerns regarding the performance and use of your appliance, please visit www.sunbeam.com.au or contact the Sunbeam Consumer Service Line. Ensure the above safety precautions are understood.

Features of your Sunbeam Air Fryer

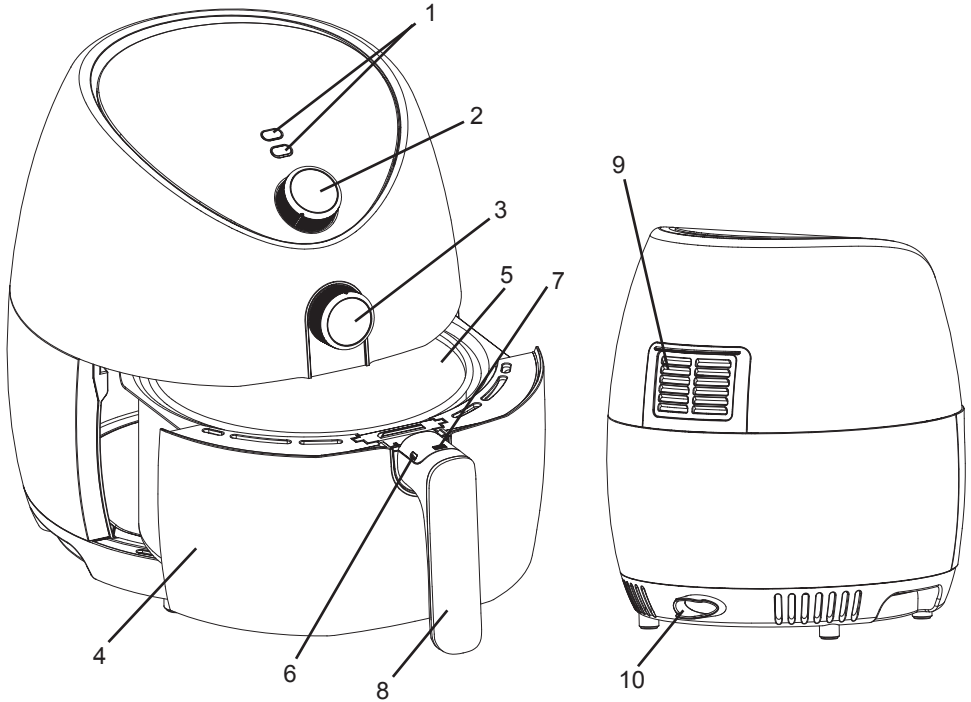

1. Power and heat indicators
2. Time control knob
3. Temperature control knob
4. Cooking tray
5. Removable cooking basket
6. Basket release shield

7. Basket release button
8. Handle
9. Heating fan vent cover
10. Power cord storage compartment

Copper Infused DuraCeramic™ bowl

This product features the exclusive Copper Infused DuraCeramic™ coating from Sunbeam®. This specialised natural ceramic coating is designed to transfer heat quicker and more efficiently than standard non-stick coatings – meaning faster cooking times for your delicious home-cooked meals. In addition, the Copper Infused DuraCeramic™ coating is scratch resistant and is PTFE and PFOA free, so not only is this exclusive coating durable and easy to clean, it's also natural and super safe for the whole family.

⚠ Never immerse any part of the air fryer body, power cord or plug in water or any other liquid. Before assembling or disassembling your air fryer, ensure it is unplugged and all parts are cool.

Unpack the appliance and remove all packaging, promotional materials and

stickers. Remove the cardboard from underneath the air fry basket. Remove all printed documents. Wash the inner basket. Basket handle in hot soapy water. Rinse then dry all of the parts. Wipe the body and lid with a damp cloth only—see page 7 for cleaning instructions.

We recommend that you wash the inner basket by hand only, in order to preserve the Copper Infused DuraCeramic™ coating.

Guide To Oils And Fats

Using your Air Fryer to cook food will help you to reduce the amount of oil needed in some recipes, which may benefit your diet. The table below lists some of the more

widely available, popular oils. All of them can be used in your Air Fryer. However, for best results, we recommend Vegetable or Rapeseed oil.

Oil Type	Use
Vegetable oil	Shallow, deep and stir frying.
Rapeseed oil (often called vegetable oil)	Shallow, deep and stir frying.
Corn oil	Shallow, deep and stir frying.
Sunflower oil	Shallow, deep and stir frying.
Olive oil	Shallow and stir frying. Marinades, dressings, drizzling.
Sesame oil	Shallow, deep and stir frying. Marinades, drizzling.
Peanut oil (often called ground nut oil)	Shallow and stir frying. Dressings. Adds a nutty flavour.
Grape Seed oil	Shallow, deep and stir frying.
You can also use low calorie cooking spray in your Air Fryer.	Always ensure that the ingredients are evenly coated with oil.

Cooking Guide

Your Air Fryer can be used to cook fresh or frozen foods. Always ensure that the ingredients are evenly coated with oil.

1. Plug the Air Fryer into an electrical outlet.
2. Turn the temperature control knob to the required temperature.
3. To switch the Air Fryer on, turn the time control knob to the desired cooking time. The power and heating lights will illuminate.
4. Use the handle to gently pull the cooking tray from the Air Fryer. Place food in the removable cooking basket and replace the tray back into the air fryer properly. If the tray is not inserted properly, the appliance will not operate.
5. To ensure crispiness, some foods require shaking halfway through the cooking process. To do this, pull the cooking tray out of the appliance by the handle and gently shake/stir the food. Then slide the tray back into the air fryer and continue to cook.
Note: Do not press the basket release button on the handle while shaking the cooking tray. Make sure the basket release shield is in place to prevent accidental release of the basket from the tray.
6. When you hear the timer bell, the set cooking time has finished. Pull the tray out of the appliance and place it on a heat resistant surface. Check if the foods are ready. If not, simply put back into the Air Fryer and set the time for a few extra minutes.
7. When the food is ready, carefully pull the cooking basket from the Air Fryer and place on heat resistant surface, then push the clear basket release shield forward with your thumb. Press the basket release button and lift the basket out of the tray. Empty basket of food into serving bowl or plate. For larger or fragile items, use tongs to lift the food out of the basket.
8. Do not use metallic utensils to take food residues out from the cooking tray or the cooking basket.
9. Use heat resistant, non-metallic utensils, to take out food from the removable cooking basket.

Cooking Popular, Convenience And Frozen Foods

The following table provides basic cooking guidelines for popular, convenience and frozen foods. Please note that due to the variations in thickness and size of the foods being cooked some experimentation may be required for the best cooking results. Always ensure that the food is thoroughly cooked to food-safe temperature throughout before consuming.

When cooking fresh fries, we've kept the oil quantities as low as possible for the healthiest results. However, if you feel the fries are a little pale and require further browning, increase the quantity of oil slightly.

Note: For crispier results it is recommended to shake the fryer basket 1-2 times throughout the cooking cycle.

Food	Cooking Time (mins)	Cooking Temp (Degrees C)	Notes	Oil (TBSP)
600g fresh fries	23-25	200	Remove and shake basket periodically	1
600g frozen fries	12-16	200	Remove and shake basket periodically	-
500g frozen potato tots	12-16	200	Cover basket in one layer	-
500g frozen cheese sticks	8-10	200	Cover basket in one layer	-
600g frozen hash browns	8-10	200	Coat basket lightly with oil	1
Frozen pizza	6-8	200		-
Frozen beef burger	8-10 medium 11-13 well done	200	Flip once	-
Frozen small chicken nuggets	14-16	200	Cover basket in one layer	-
Fresh chicken breast	16-20	200	Wash and pat dry	1
Fresh chicken drumsticks	20-25	200	Wash and pat dry	1

Care And Cleaning

▲ Always unplug your Air Fryer and allow it to cool completely before cleaning it. NEVER immerse the MAIN body, power cord or plug in water or any other liquid. To prevent damage to the appliance do not use alkaline cleaning agents when cleaning, use a soft cloth and a mild detergent.

- Carefully wipe any oil spatter from the heating fan cover with kitchen paper. Wipe over the outer body with a clean, slightly damp cloth and dry.
- Wash the removable cooking basket, and handle with warm soapy water using a cloth, sponge or non-abrasive brush. Dry completely before use or storage.
- We recommend that you wash the inner basket by hand only, in order to preserve the Copper Infused DuraCeramic™ coating.

To remove the cooking basket from the tray:

1. Slide the basket release shield forward.
2. Press the basket release button.
3. To refit basket to the cooking tray, position the basket over the top of the body then pivot the basket downward into place until the lock clicks.

This appliance has no user serviceable parts. Any servicing beyond that described in the Cleaning Section should be performed by an Authorized Service Representative only. See Warranty Section.

Troubleshooting

Problem	Possible Reason	Solution
Air fryer does not turn on	<ul style="list-style-type: none">• Basket is not inserted properly.• Timer is not set.	<ul style="list-style-type: none">• Insert the basket properly, ensuring it clicks into the closed position.• Turn the timer dial on the control panel to set the time.
Food is not evenly cooked	<ul style="list-style-type: none">• Too much food in inner bowl.	<ul style="list-style-type: none">• Remove food from the bowl and cook in smaller batches.
Chips are not crispy	<ul style="list-style-type: none">• Potatoes have too much starch in them.• Old potatoes used.• Not enough oil added.• Potatoes cut too large.	<ul style="list-style-type: none">• Wash potatoes thoroughly and dry before frying.• Use fresh potatoes.• Add slightly more oil.• Cut potatoes into smaller pieces.
Chips not evenly cooked	<ul style="list-style-type: none">• Chips were not shaken halfway through the cooking process.	<ul style="list-style-type: none">• Shake chips halfway through the cooking process.

12 Month Replacement Guarantee

This Sunbeam product is covered by a 12 month replacement or repair warranty, which is in addition to your rights under the Australian Consumer Law (if your product was purchased in Australia) or New Zealand Consumer Guarantees Act (if your product was purchased in New Zealand).

Upon receipt of your claim, Sunbeam will seek to resolve your difficulties or, if the product is defective, advise you on how to obtain a replacement or refund.

To assist us in managing warranty claims, we recommend you register your product as soon as practicable after purchase by creating a MySunbeam account on our website and uploading a copy of your original receipt.

In order to make a claim under our warranty, you must have the original proof of purchase documentation for the product and present it when requested (if not already uploaded to our website).

Should your product develop any defect within 12 months of purchase because of faulty materials or workmanship, we will replace or repair it, at our discretion, free of charge. A product presented for repair may be replaced by a refurbished product of the same type rather than being repaired. Refurbished parts may be used to repair the product.

Our replacement or repair warranty only applies where a defect arises as a result of faulty material or workmanship during the warranty period. Your warranty does not cover misuse or negligent handling (including damage caused by failing to use the product in accordance with this instruction booklet), accidental damage, or normal wear and tear.

Your warranty does not:

- cover freight or any other costs incurred in making a claim, consumable items, accessories that by their nature and limited lifespan require periodic renewal (such as filters and seals) or any consequential loss or damage; or

- cover damage caused by:
 - power surges, power dips, voltage supply problems, or use of the product on incorrect voltage;

- servicing or modification of the product other than by Sunbeam or an authorised Sunbeam service centre;
- use of the product with other accessories, attachments, product supplies, parts or devices that do not conform to Sunbeam specifications; or
- exposure of the product to abnormally corrosive conditions; or

- extend beyond 3 months if the product is used in commercial, industrial, educational or rental applications.

The benefits given to you by our warranty are in addition to other rights and remedies under law in relation to the product.

In Australia our goods come with guarantees that cannot be excluded under the Australian Consumer Law. You are entitled to a replacement or refund for a major failure and for compensation for any other foreseeable loss or damage. You are also entitled to have the goods repaired or replaced if the goods fail to be of acceptable quality and the failure does not amount to a major failure.

Our goods also come with guarantees that cannot be excluded under the New Zealand Consumer Guarantees Act.

If your warranty claim is not accepted, we will inform you and if requested to do so by you, repair the product provided you pay the usual charges for such repair. You will also be responsible for all freight and other costs.

Should your product require repair or service after the warranty period, contact your nearest Sunbeam service centre. For a complete list of Sunbeam's service centres, visit our website or call our customer service line for advice on 1300 881 861 in Australia, or 0800 786 232 in New Zealand.

Should you experience any difficulties with your product during the warranty period, please contact our customer service line for advice on 1300 881 861 in Australia, or 0800 786 232 in New Zealand.

Australia

www.sunbeam.com.au
1300 881 861
Suite 1, Level 1,
13 Lord Street,
Botany NSW 2019
Australia

New Zealand

www.sunbeam.co.nz
0800 786 232
Level 6, Building 5,
Central Park,
660-670 Great South Road,
Greenlane, Auckland
New Zealand

Need help with your appliance?

Contact our customer service team
or visit our website for information
and tips on getting the most from
your appliance.

Australia | **visit** www.sunbeam.com.au
phone 1300 881 861
mail Suite 1, Level 1, 13 Lord Street,
Botany NSW 2019 Australia.

New Zealand | **visit** www.sunbeam.co.nz
phone 0800 786 232
mail Level 6, Building 5,
Central Park,
660–670 Great South Road,
Greenlane, Auckland.

NEWELL AUSTRALIA PTY LTD. ABN 68 075 071 233

Sunbeam is a registered trade mark.

'DuraCeramic' is a trade mark of Sunbeam Corporation.

Made in China to Sunbeam's specification.

Due to minor changes in design or otherwise,

the product you buy may differ slightly from the one shown here.

Approved by the appropriate electrical regulatory authorities.

©Sunbeam Corporation Limited 2020.

07/20

4020A-IB

AFP4000WH_AFP4000BK_20EM2 (ANZ)

GCDS-SUN-SL