



# User Manual

Ultrasonic Humidifier

---

**READ AND SAVE THESE INSTRUCTIONS**

---

**MODEL NUMBER**

---

SCWA-4006

---



## Welcome to the TOSOT Direct Family!

We're extremely happy to welcome you as a new member of our family! To thank you, we're giving you a warranty extension. Are you interested? All you need to do is register your product at [www.tosotdirect.com/extend](http://www.tosotdirect.com/extend). Once your product is registered, we'll automatically give you a 6-month extension on the manufacturer warranty. It's that easy!

You'll also get a quick start guide so you can know how to set up and use your product for the first time.

## Tips for First-Time Use

1. Before using the humidifier for the first time, let the unit sit in a room temperature environment for at least 30 minutes before powering on.
2. The suitable operating environment for this product is 41 °F – 104 °F (5°C – 40°C) with a relative humidity level of less than 70%.
3. For best results use clean, distilled water that is less than 104 °F (40°C) in temperature.
4. If you have not operated the humidifier within the last month, please clean the water channel and water tank before powering on.
5. Replace the water in the water tank and water channel every day to prevent the growth of bacteria.

# Table of Contents

Important Safety Instructions .....	01
FCC Compliance .....	01
Electric Schematic .....	03
Polarized Plug Notice .....	03
Technical Specs .....	04
Parts List .....	05
Features .....	06
Button/Light Functions .....	06
Aromatherapy .....	07
Night Light .....	07
How Ultrasonic Humidifiers Work .....	07
Using Your Humidifier .....	08
Cleaning and Maintenance .....	08
Maintenance Checklists .....	08
Cleaning the atomizer: .....	09
Cleaning the water tank: .....	10
Cleaning the water channel: .....	10
Troubleshooting .....	10
Frequently Asked Questions .....	12

## **Warning**

This symbol throughout the manual points out a potentially hazardous situation that if not avoided may result in death or serious injury. Please use caution when operating this device.

# Important Safety Instructions

Please read all instructions before use and save this user manual for future reference. A digital version can be found by visiting the product page on our website, [www.tosotdirect.com](http://www.tosotdirect.com), or by contacting [support@tosotdirect.com](mailto:support@tosotdirect.com) to ask for a digital version.

Your safety and the safety of others are very important to us. We have provided many important safety messages throughout this manual and on the appliance itself. Always read and follow all posted safety messages. If you have any doubt, please contact [support@tosotdirect.com](mailto:support@tosotdirect.com) with any questions.

**This appliance is not intended for use by persons (including children) with reduced physical, sensory or mental capabilities or lack of experience and knowledge, unless they have been given supervision or instruction concerning use of the appliance by a person responsible for their safety. Children should always be supervised to ensure that they do not play with the appliance.**

**When using electrical appliances, basic precautions should always be followed to reduce the risk of fire, electric shock, injury to persons, and property loss. These precautions include, but are not limited to, the following:**

1. Please keep plastic bags and sheets out of the reach of children as they might be mistakenly used for play. Packaging materials can become airtight chambers and may pose a risk of suffocation if not disposed of properly.
2. Before using the humidifier, check the power cord for any signs of damage. If the cord is found to be damaged, DO NOT USE and return the humidifier to the manufacturer under the warranty agreement for repair.
3. To avoid fire or shock hazard, plug the appliance directly into a 120V AC electrical outlet only.
4. Keep the cord out of heavy traffic areas, to avoid fire hazard. NEVER put the cord under rugs or near heat registers.

5. This appliance has a dual-prong polarized plug (one blade is wider than the other). To reduce the risk of shock, this plug is intended to fit only one way in a polarized outlet. If the plug does not fit securely in the outlet, reverse the plug. If it still does not fit, contact a qualified electrician. DO NOT attempt to defeat this safety feature.
6. A loose fit between the AC outlet (receptacle) and plug may cause overheating and a distortion of the plug. Contact a qualified electrician to replace loose or worn outlet.
7. Do not use an extension cord to reduce risk of fire or electric shock.
8. WARNING: Do not attempt to refill humidifier without first unplugging the unit from its electrical outlet. Failure to heed this warning may cause personal injury.
9. Humidifier should be unplugged when not in use. To disconnect the humidifier, first turn controls to the OFF position, then grip the plug and remove from the wall outlet. Never pull by the cord. Do not operate or pull the plug with wet hand.
10. Do not use humidifier in an area where humidity level is in excess of 70%. Use a hygrometer, available at your local retailer or through the manufacturer, to measure the humidity level in your home.
11. NEVER drop or insert any object into any openings of the humidifier.
12. Do not use the humidifier outdoors. Any other use not recommended by the manufacture may cause fire, electric shock, or injury to persons. The use of attachments not recommended or sold by the manufacture may cause hazards.
13. Always follow the cleaning and maintenance instructions. Always power off and unplug the power cord from wall outlet before cleaning or performing maintenance.
14. The humidifier should always be unplugged and emptied when not in operation or while being serviced or cleaned.
15. Do not direct moisture flow directly at individuals, walls or furniture. When a humidifier is used in a closed room or small rooms, check periodically for proper ventilation, as excessive humidity can cause condensation stains on walls.
16. Do not disassemble or repair the humidifier by yourself as this may cause electric shock, fire hazard or personal injury. Always contact the manufacturer or turn to an experienced technician for help.
17. If the product makes a strange noise or emits a strange or smoky smell, immediately remove the power plug and contact customer service for next steps.

18. NEVER operate unit without water in the tank.
19. Do not touch the water in the humidifier when the humidifier is connected into power supplies. Do not move the unit until it has completely cooled off after operation.
20. Never place anything over moisture outlet when the unit is running.
21. Do not pour water in any openings other than the water tank.
22. NEVER use detergents, gasoline, glass cleaner, furniture polish, paint thinner, or other household solvents to clean any part of the humidifier.

## Electric Schematic

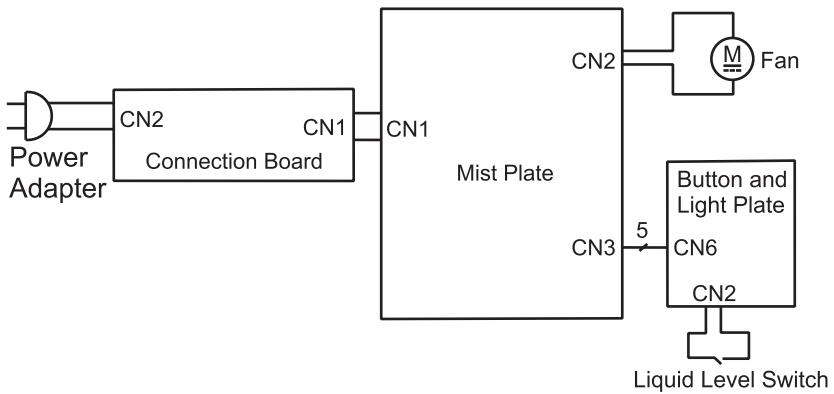

SCWA-4006

## Polarized Plug Notice



**DO NOT ATTEMPT TO MODIFY THIS PLUG OR DEFECT THIS SAFETY FEATURE IN ANY WAY.**

**THIS APPLIANCE HAS A POLARIZED PLUG (One blade is wider than the other).** To reduce the risk of electric shock, this plug is intended to fit in a polarized outlet only one way. If the plug does not fit fully in the outlet, reverse the plug. If it still does not fit, contact a qualified electrician to install the proper outlet.

# Technical Specs

Model	SCWA-4006
Working Voltage	24 V DC
Rated Power Input	20W
Tank Capacity	1.06Gal / 4.0 L
Max Humidifying Volume	4.5L/24h
Max Noise Level	38dB(A)
Unit Dimensions (LxWxH)	7.5 in x 7.5 in x 12.7 in
Power Adapter Rated Input	100-240V~, 50/60Hz, 1.0 A
Power Adapter Output	24V 1.5A

## **Notes:**

***Humidifying volume will change according to the changes in indoor temperature and humidity levels.***

***If using water that is colder than room temperature the humidifying volume will be lower than volume noted in technical specs. The volume should increase as the water temperature reaches room temperature.***

## Parts List

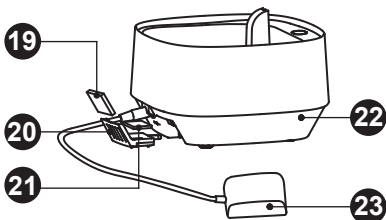
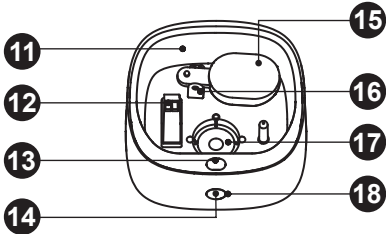
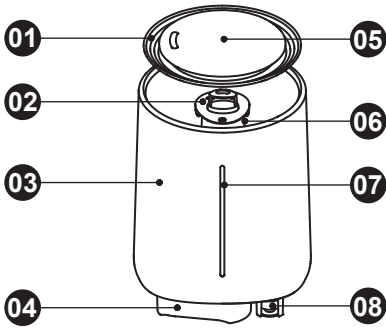

- 01 Decorative Ring
- 02 Transfer Pipe
- 03 Water Tank
- 04 Mist Reinforcement
- 05 Mist Outlet Cover
- 06 Mist Outlet
- 07 Water Gauge
- 08 Float
- 09 Filter
- 10 Water Cover Subassembly
- 11 Water Channel
- 12 Air Outlet
- 13 Water Tank Light
- 14 Button
- 15 Float Plate
- 16 Supporter
- 17 Atomizer
- 18 Light Ring
- 19 Carbon Filter
- 20 Fragrance Box
- 21 Fragrance Sponge
- 22 Bottom Cover
- 23 Power Adapter

### Notes:

*If the structure diagram of product is subject to change without prior notice. Please refer to the actual product.*

# Features

## Button/Light Functions

Operation/Action	Result/Explanation
Short press the button	Cycle between 3 mist output levels (low/medium/high) or standby mode.
Long press the button	While humidifying, holding for 2 seconds turns the water tank light on/off . While plugged in but not dehumidifying, holding for 2 seconds engages standby mode.
Light ring turns to red	Standby mode.
Light ring turns to white	The brightness of the light ring indicates the mist output level. The brighter the light, the higher the mist output.
Light ring is flickering/blinking red	The unit is in standby mode and requires your attention. <ul style="list-style-type: none"><li>● Flashes 2 times: unit is in water shortage protection. Fill tank with water or place tank correctly on the basin.</li><li>● Flashes 3 times: unit is in dry-burning protection. Unplug power cord, refill tank with water, and plug power cord back in.</li><li>● Flashes 5 times: unit is experiencing jumper cap failure. Please contact customer service for support.</li></ul>
Light ring goes dark	If the unit is not operated for 40 seconds, the light ring will go dark. Any input from you will wake the machine.
Color of water tank light	The water tank will light up in purple.

## Aromatherapy

This Model SCWA-4006 Ultrasonic Humidifier is equipped with an aromatherapy function. To use, press in the aromatherapy fragrance box and remove from unit. Add a few drops of your selected fragrance to the fragrance sponge and then slide the fragrance tray back into the humidifier.

Do not add fragrance or essential oils directly into the water tank. This can damage the internal components and will immediately void the manufacturer warranty of your humidifier.

## Night Light

Under working status, long press and hold the button for 2 seconds to turn the night light in the tank on or off. Please check the table above for more information about the functions of the night light and button.

## How Ultrasonic Humidifiers Work

The Ultrasonic Cool Mist Humidifier is designed to quietly provide visible cool moisture. Water is released from the water tank into the transducer nebulizer where it is turned into a fine visible mist through the action of ultrasonic sound waves. The mist is then propelled into the air by a small fan providing relief from discomfort caused by dry air.

# Using Your Humidifier

1. Use both hands to remove the water tank from the base of humidifier unit. If the water tank contains water, you may need to place your second hand on the bottom to support the water tank after removing from base.
2. Remove the mist outlet cover from the top of the water tank and fill with water.
3. After filling the water tank, place the water tank back onto the base of the humidifier.
4. Reinstall the mist outlet cover, taking care to align the notch of the mist outlet cover within the groove on the water tank. The mist outlet can be rotated 360 to choose the optimal mist direction for your needs.
5. Press the button on the front of the humidifier to select the proper mist volume.
6. If the light ring is white, your humidifier is good to go! If light ring is red, you need to add more water to the water tank.

## **Note:**

*The optimal relative humidity level is anywhere within 40-60% RH. Relative humidity levels above 60% RH may increase the chance of mold or mildew growth. You may need to purchase a hygrometer to accurately measure the relative humidity setting in your home.*

## Cleaning and Maintenance

### Maintenance Checklists

#### Pre-Season Maintenance Checklist

- Check the power cord for any cuts or exposed wiring
- Empty and clean the water tank, dry after cleaning
- Remove and clean the carbon air filter, dry after cleaning

## Long-Term Storage Checklist

- Unplug humidifier from power outlet and wrap up power cord
- Empty and clean the water tank, dry after cleaning
- Remove and clean the carbon air filter, dry after cleaning
- Wrap and/or cover the unit to prevent the accumulation of dust

## Types of Water

Depending on the water treatment methods in your local area, water added from the tap may be rich in calcium, magnesium, or other hard minerals. After using the humidifier, some of these minerals may collect on or inside your humidifier in the form of a white, sometimes powdery, substance. For this reason, we commend that you use distilled water in your humidifier to limit the buildup of these hard-mineral deposits.

## Carbon Filter

Located on the bottom of your humidifier is a black, sponge-like material which is the carbon filter for the air intake. This filter may attract large quantities of dust or other debris from the surrounding air after continued use, depending on your local environment.

The atomizer, water tank, and water channel should be cleaned weekly.

## Cleaning the atomizer:

1. Place approx. 2 tsp. of distilled white vinegar onto the surface of the atomizer and let sit for 2-5 minutes. Increase or decrease the amount of vinegar depending on the amount of hard-mineral deposits.
2. Gently scrub the surface of the atomizer with the included soft cleaning brush until any mineral deposits are removed.
3. Rinse the surface of the atomizer with clean water to remove any remaining vinegar.

## Cleaning the water tank:

1. Add approx. 2 tsp. of white into the water tank and fill water tank approx.  $\frac{1}{4}$  full of clean water.
2. Tighten the nut of water tank and shake vigorously to ensure all surfaces are reached with the cleaning mixture.
3. Empty the drain bucket and rinse with clean water to remove any remaining vinegar.

## Cleaning the water channel:

1. If there are any hard-mineral deposits on the water channel, dip a soft cloth with white vinegar and wipe away. For larger deposits, you may need to use the included soft cleaning brush.
2. Rinse with clean water to remove any remaining vinegar.

## Troubleshooting

If your humidifier is not function properly please check the below table for the issue and solution. Please contact [support@tosotdirect.com](mailto:support@tosotdirect.com) if you have any additional questions or the issue you are experiencing is not listed.

Issue	Possible Cause	Solution
Humidifier does not power on	The power plug is not fully inserted into the outlet.	Re-insert the power plug.
	There's no water in the tank.	Fill the tank with water.
	The water tank is not properly seated.	Installed the water tank correctly.
The mist smells weird	The water is dirty, or the water has been in the tank for too long.	Clean the water tank and replace with clean water

Issue	Possible Cause	Solution
Poor mist output	The carbon filter is dirty or blocked.	Clean the carbon filter and ensure it is no longer blocked.
Mist is overflowing around the air outlet cover	There is a gap between the air outlet cover and the water tank.	Reposition the air outlet cover to align with the groove on the water tank. Wipe excess water with a soft cloth.
Water leakage around unit	The mist is not scattering completely or cannot be absorbed by the air due to poor air circulation or high ambient humidity level.	Decrease the mist volume via the control knob or use an air conditioner/fan to increase air circulation.
Strange noises from humidifier	The unit has been placed on an unstable surface.	Relocate the unit to a flat, solid surface.
Water tank contains water, but the tank indicator light is glowing red.		

**⚠ CAUTION**

This product can expose you to toxic chemicals including Di (2-ethylhexyl) phthalate (DEHP), which may cause cancer or harm developmental growth.

Wash hands after installation.

For more information go to [www.p65Warnings.ca.gov](http://www.p65Warnings.ca.gov)



# Frequently Asked Questions

To view the complete list of frequently-asked questions, please visit [www.tosotdirect.com/faq](http://www.tosotdirect.com/faq).

## **How do I know the humidity level in my home?**

This humidifier is not equipped with a digital hygrometer to measure the humidity level in your home. Optimal humidity levels are 40-60% relative humidity. Humidity levels greater than 60% can lead to growth of mold and mildew, while humidity levels below 40% can cause skin dryness/irritation, respiratory system discomfort, and buildup of static electricity. In physical objects, low humidity levels can cause wood furniture or trim to shrink and drywall to crack.

We recommend purchasing a hygrometer (digital or analog) to measure the humidity level in the area where you are planning to use the humidifier.

## **Can I use this humidifier for aromatherapy treatment?**

This humidifier (Model SCWA-4006) is equipped with a tray for aromatherapy, fragrances, or essential oils. However, do not add scented oils or anything but water to the water tank, as this may degrade the internal components and will void your manufacturer warranty.

## **What is the white dust around my humidifier?**

In the process of humidifying, you may notice a white dust or powder collecting inside of, or on the area immediately surrounding your humidifier. This dust is from the hard minerals in the water you added to the water tank and is not harmful. The dust is near-impossible to avoid, but can be greatly reduced by using only distilled, mineral-free water in your humidifier.

## **What happens if my unit isn't working? Does my unit have a warranty?**

Please contact us at [support@tosotdirect.com](mailto:support@tosotdirect.com) if you have any questions about your unit. If you haven't already done so, you will be asked to register your product for warranty on our website. You can speed up that process by visiting [www.tosotdirect.com/extend](http://www.tosotdirect.com/extend) to give us some information about your unit. All products are covered under a one-year warranty from the date you place your order.

# TOSOT

TOSOT Direct  
[www.tosotdirect.com](http://www.tosotdirect.com)

Customer service: [support@tosotdirect.com](mailto:support@tosotdirect.com)

Facebook: [www.facebook.com/tosotdirect](http://www.facebook.com/tosotdirect)

Instagram: [@tosotdirect](https://www.instagram.com/tosotdirect)

Twitter: [@tosotdirect](https://twitter.com/tosotdirect)