



DualZone Air Fryer

use & care

Introduction2
Important Safety Information3
Features6
Controls & Operation7

Care & Cleaning 14
Troubleshooting..... 15
Limited Warranty 16



2

INTRODUCTION

Welcome to our family

This manual is your resource for the use and care of your product. Please read it before using your appliance. Keep it handy for quick reference. If something doesn't seem right, the troubleshooting section will help you with common issues.

Visit Owner Support on www.frigidaire.com for access to FAQs, how-to videos and articles, accessories and cleaning products.

We are here for you! Visit our website, chat with an agent, or call us if you need help. If you do need service, we can get that started for you.

For Peace of Mind Protection, register your product. Locate your registration card and/or label on your product with the photo register icon.

Keep your product info here so it's easy to find.

Model Number: _____

Serial Number: _____

Purchase Date: _____

Definitions

 This is the safety alert symbol. It is used to alert you to potential personal injury hazards. Obey all safety messages that follow this symbol to avoid possible injury or death.



DANGER

DANGER indicates an imminently hazardous situation which, if not avoided, will result in death or serious injury.



WARNING

WARNING indicates a potentially hazardous situation which, if not avoided, could result in death or serious injury.

Conforms to UL Std.1026

Certified to CSA Std. CSA C22.2
No.60335-1:16&No.60335-2-9:20



Intertek

Product Information

Power: 120V 60Hz 1800W

ATTENTION

Please read all instructions related to your product and keep this manual for your future reference. Follow all the warnings and instructions described in this manual to better use your product and get better results.

ENVIRONMENT

Frigidaire is committed to offering products that have less impact on the environment, thus contributing to the sustainable development. Electronic equipment, cells and batteries must be disposed of separately from ordinary waste. If your equipment has cells or batteries, when they are replaced or discarded, they must be sent to an Frigidaire Authorized Service so that they have a suitable destination. Environmentally sound preparation of packaging and products at the end of life is everyone's responsibility.



CAUTION

CAUTION indicates a potentially hazardous situation which, if not avoided, may result in minor or moderate injury.



IMPORTANT

IMPORTANT indicates installation, operation or maintenance information which is important but not hazard-related.

IMPORTANT SAFEGUARDS

SAFETY PRECAUTIONS

Read all instructions before using the electric appliance. When using electrical appliances, basic safety precautions should always be followed including the following:

- Children should not play with the appliance. Cleaning and maintenance should not be performed by children without supervision. Close supervision is necessary when the appliance is used by or near children.
 - This appliance is not intended for use by persons (including children) with reduced physical, sensory or mental capabilities, or lack of experience and knowledge, unless they have been given supervision or instruction concerning use of the appliance by a person responsible for their safety.
 - Please keep the appliance and the power cord out of the reach of children.
 - After unpacking the product, keep the packaging material out of reach of children.
 - This appliance is intended for normal household use only. Not for commercial use.
 - Check that the supply voltage is the same as the product label before connecting it.
 - Unplug from outlet when not in use and before cleaning. Allow to cool down before putting on or taking off parts.
 - Do not operate any appliance with a damaged cord or plug or after the appliance malfunctions or has been damaged in any manner. Always make sure that the plug is inserted properly into a wall outlet.
- a) A short power-supply cord (or detachable power-supply cord) is provided to reduce the risk resulting from becoming entangled in or tripping over a longer cord.
- Regularly inspect the appliance and power cord. If the power cord is damaged or broken, it must be replaced by a service agent or similarly qualified persons to avoid safety hazards.
 - Return appliance to the nearest authorized service facility for examination, repair, or adjustment. Do not attempt to repair the appliance by yourself.
 - Keep the power cord away from hot surfaces or sharp objects to avoid damage. Do not use an extension cord. Do not use an outlet under the counter.
 - Do not excessively pinch, bend, twist or place heavy objects on the power cord to prevent from exposing or breaking its shielding. Do not use the electrical cord to pull or drag the product.
 - Do not let cord hang over edge of table or counter, or touch hot surfaces.
 - Always attach plug to appliance first(if applicable), then plug cord into the wall outlet. To disconnect, turn any control to "off", then remove plug from wall outlet.
 - The accessible surfaces may become hot during use. Do not touch hot surfaces. Use handles or Knobs.
 - Do not cover the air inlet and the air outlet openings while the appliance is operating.
 - Never unplug the product from the outlet by pulling on the electrical cable, use the plug.
 - Do not place the appliance on or near a hot gas or electric burner, or in a heated oven. Do not use outdoors.

IMPORTANT SAFEGUARDS

- Never put anything flammable, explosive or corrosive in the basket or trays. Never place paper, cardboard, non-heat-resistant plastic or similar combustible materials into your appliance. Never put baking or parchment paper into the appliance without food on top. Air circulation can cause paper to lift and touch heating coils.
 - Do not pour oil into the cooking basket or trays.
 - Be careful of small parts.
 - Extreme caution must be used when moving an appliance containing hot oil or other hot liquids.
 - Do not insert pins, wires or other objects into any of the openings of the appliance to avoid an electrical shock or injury.
 - To protect against electric shock, do not immerse the cord, plug, or housing in water or other liquids.
 - Do not move or shake the appliance during use.
 - Immediately unplug the unit if the unit emits black smoke.
 - Do not leave your appliance unattended while in use.
 - Do not store items on top of the appliance when it is turned on.
 - Do not use appliance for other than intended use.
 - When cooking, DO NOT place the appliance against a wall or against other appliances. Leave at least 4"/10 cm of free space on the back, sides, and 5"/12.7cm above the appliance. DO NOT operate the appliance on or near combustible materials. DO NOT block any ventilation openings as hot steam is released through them. DO NOT place anything on top of the appliance.
 - The use of accessory attachments not recommended by the appliance manufacturer may cause injuries.
 - Please be cautious when taking out and replacing the cooking basket. Improper operation may cause pinching hazards.
 - Oversize foods or metal utensils must not be inserted in a appliance as they may create a fire or risk of electric shock.
 - A fire may occur if the appliance is covered or touching flammable material, including curtains, draperies, walls, and the like, when in operation. Do not store any item on top of the appliance when in operation.
 - Do not clean with metal scouring pads. Pieces can break off the pad and touch electrical parts involving a risk of electric shock.
 - Do not store any materials, other than manufacturers recommended accessories, in this appliance when not in use.
 - Do not cover trays, racks, or any part of the appliance with metal foil. This will cause overheating of the appliance.
 - Do not touch the sharp parts of the machine to avoid cuts.
 - Do not put the product into the cabinet.
 - The appliances are not intended to be operated by means of an external timer or separate remote-control system.
- Any changes or modifications are not expressly approved by the party responsible for compliance could void the use's authority to operate the equipment.

This device complies with Part 15 of the FCC Rules. Operation is subject to the following two conditions: (1) this device may not cause harmful interference, and (2) this device must accept any interference received, including interference that may cause undesired operation.

CAN ICES-003 (B) / NMB-003 (B)

Note: Items marked with the following symbol may reach high temperature and should be handled carefully.



CAUTION

- Objects in the direct path of the hot air vent may suffer damage such as deformation or staining.
- The appliance is not intended for use as a barbecue. The use of coal or wood inside the appliance presents a high risk of fire.



WARNING

FIRE/ELECTRICAL SHOCK HAZARD

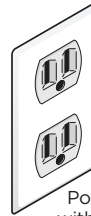

Grounding-type wall receptacle

Power Cord with 3-prong grounded plug

DO NOT under any circumstances, cut, remove, or bypass the grounding prong.



WARNING

CALIFORNIA RESIDENTS ONLY:
For cancer and reproductive harm information visit:
www.P65Warnings.ca.gov

FOR HOUSEHOLD USE ONLY
SAVE THESE INSTRUCTIONS FOR
FUTURE REFERENCE.

6

FEATURES

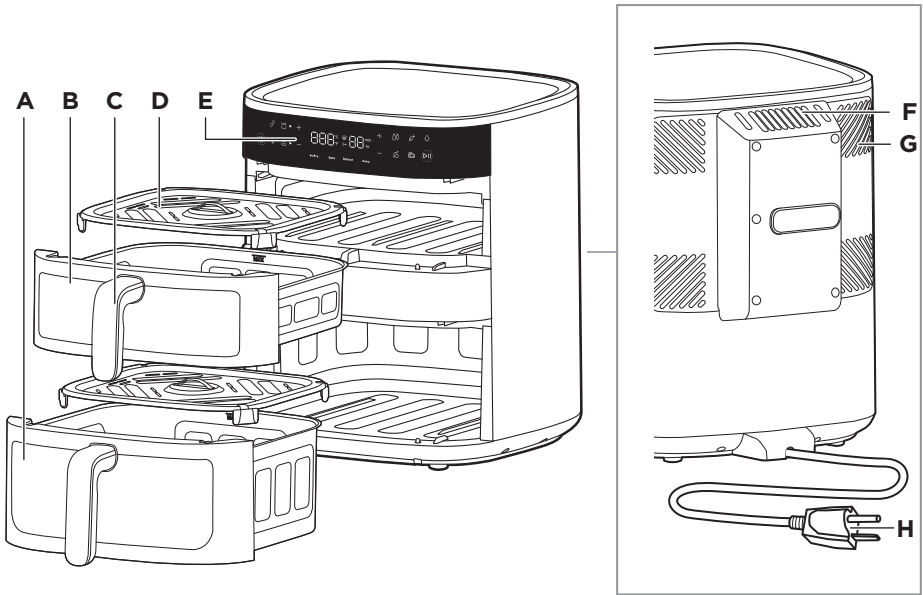

- A** Bottom basket(7.60Qt) **C** Basket handle **E** Control panel **G** Cooling system
B Top basket(4.23Qt) **D** Basket Tray **F** Air outlet **H** Power cord

Accessories (for some models only)

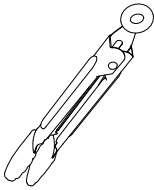

Cooking tongs

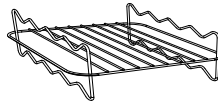

Wire Rack

Before First Use

1. Remove all packaging materials and promotional labels from the inside and outside of the appliance.
2. Place the appliance on a stable, level and heat-resistant surface, leaving enough space to open the door.
3. Clean the appliance and accessories (see CARE & CLEANING).

NOTE

Before the first use, operate the Air Fry mode for 20 minutes. You may notice a small amount of smoke and/or an odor of oil, which is normal.

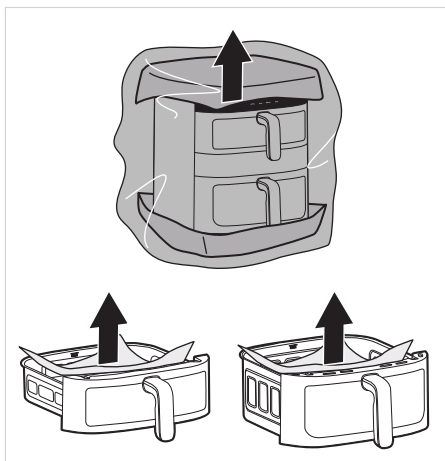

Control Panel

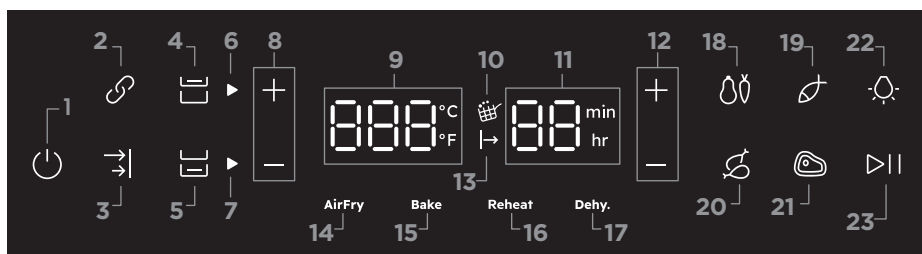

- | | | |
|--------------------------------|-------------------------------|------------------------------|
| 1. On/Off button | 9. Temperature indicator | 18. Vegetables preset button |
| 2. Sync cook button | 10. Shake indicator | 19. Fish preset button |
| 3. Sync Finish button | 11. Time indicator | 20. Drumstick preset button |
| 4. Top basket button | 12. Time control buttons | 21. Steak preset button |
| 5. Bottom basket button | 13. Waiting to cook indicator | 22. Light button |
| 6. Top basket indicator | 14. AirFry button | 23. Play/Pause button |
| 7. Bottom basket indicator | 15. Bake button | |
| 8. Temperature control buttons | 16. Reheat button | |
| | 17. Dehy. button | |

Using your Air fryer

Placement Instructions

- Place the appliance on a stable, level and heat-resistant surface leaving enough room to take out the cooking basket.
- Do not place the appliance against a wall or other appliances.
- Leave at least 4"(10cm) free space on the back and sides, and 5"(12.7cm) above the appliance to ensure proper

ventilation. Do not place any objects within these areas to prevent fire hazards.



IMPORTANT

Do not obstruct the air outlets of the product.

Mode selecting and setting

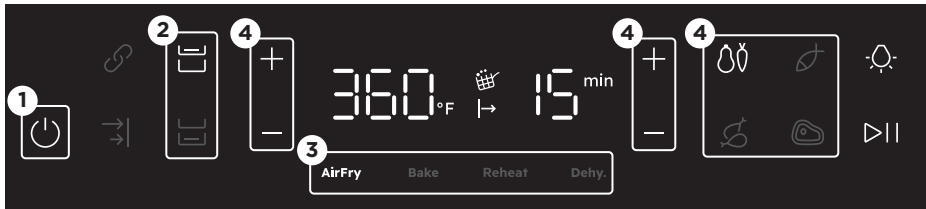

- Plug in the appliance. Then press the On/Off button to turn on the appliance.
- Press the "Top Basket Button" or "Bottom Basket Button" to select desired basket. The selected basket's button light will stay fully lit, while the other one will remain dim.
- Choose the mode you want to use.
- Choose the appropriate preset based on different ingredients, or manually adjust the temperature and time settings.

The **AirFry** mode offers 4 distinct presets for different food types: Vegetable, Fish, Drumstick, and Steak. After selecting AirFry mode, you can choose one of these presets. Alternatively, you may manually adjust the temperature and time settings.

For **Bake**, **Reheat**, and **Dehy.** modes, only one preset is available for each. Once you select any of these modes, the default settings will be displayed automatically. You can also manually modify the temperature and time if needed.

Temperature & Timer Adjustment Range

Mode	Temp. Range	Timer range
AirFry	140 - 400°F (60 - 200°C)	1 - 99min
Bake	140 - 400°F (60 - 200°C)	1 - 99min
Reheat	140 - 400°F (60 - 200°C)	1 - 99min
Dehy.	100 - 175°F (40 - 80°C)	1 - 5hours

Note: In Dehy. Mode, the time can only be adjusted in 1-hour increments.

Sync cook function

The top and bottom cooking baskets can be operated independently to run different functions. Alternatively, you can use the "Sync cook function" to sync their operations, allowing both the top and bottom baskets to execute the same settings.

Press the Sync cook button to activate this function.



Both top basket and bottom basket button will be on. Select your desired mode and set the temperature/timer once—both the top and bottom cooking baskets will execute the same settings.

Sync finish function

When the top and bottom cooking baskets have been set with their respective functions, press the "Sync Finish Button" to activate the Sync Finish function. Once activated, the appliance will first start the basket with the longer cooking time. The basket with the shorter cooking time will start with a delay, ensuring both the top and bottom baskets finish cooking simultaneously.



This function can only be activated when both the top and bottom cooking baskets have their modes selected.

If one of the cooking baskets is paused during the cooking process, it may result in inconsistent final completion times for the two baskets.

NOTE

Press the temperature "+" and "-" at the same time for 5 seconds will change the temperature unit between "°F" or "°C".

Food Preparation

1. Pull out the cooking basket and check if its tray is properly installed.

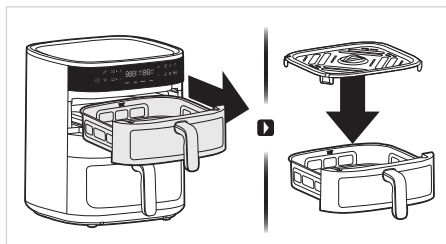

2. Place the prepared ingredients into the basket.
3. Slide the cooking basket back into the appliance until it locks into place.

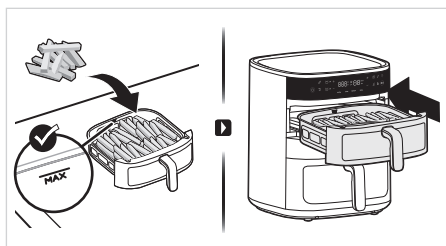

Cooking Process

Start cooking

Choose the basket that you want to start cooking.

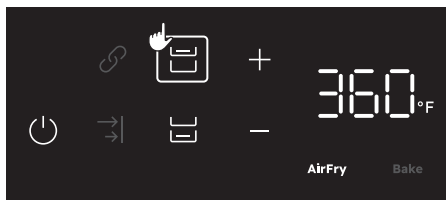

Press the "Play/Pause" button to start the cooking process.

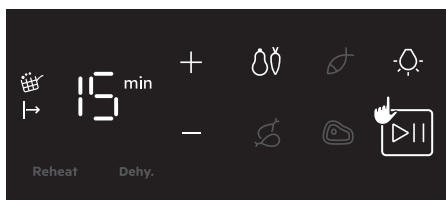

10 CONTROLS & OPERATION

Press the “Play/Pause” button again can pause the cooking process.

NOTE

When the “Sync Cook Function” or “Sync Finish Function” is activated, you only need to press the “Play/Pause” button once to start/pause both cooking baskets simultaneously.

Otherwise, each time you press the “Play/Pause” button, only the selected cooking basket will start/pause.

During operation, the Operation Indicator the active cooking basket will illuminate.

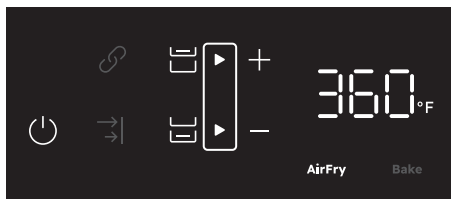

During operation, press the Top/Bottom Basket Button to check the mode, temperature setting, and remaining time for the corresponding basket.

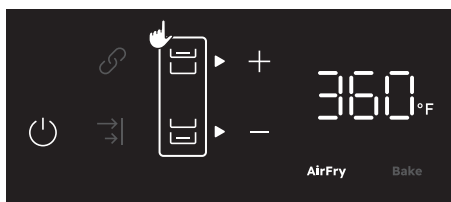

During cooking process, you can press the temperature control / time control buttons to change the temperature / time setting.

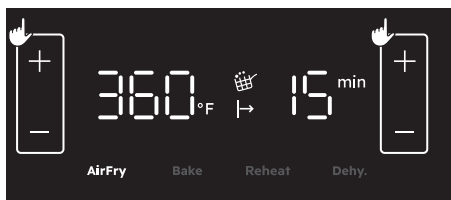

Shake or Flip Reminder

When half the cooking time is up, the Shake Reminder indicator turns on and the appliance beeps to remind you to shake or flip the food.

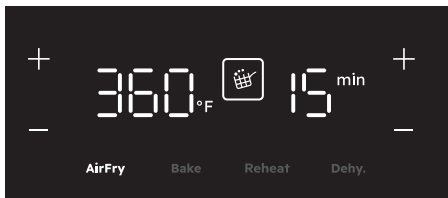

NOTE

- If no action is taken within 1 minute, the appliance will stop reminding.
- The operation will pause automatically when the cooking basket is pulled out, and resume automatically once the basket is pushed back in.
- When the Sync Finish Function is activated, pulling out only one of the two baskets will cause both the top and Bottom baskets to pause operation simultaneously.
- For Drumstick, when the cooking time exceeds 30 minutes, a reminder will sound every 10 minutes.
- Each time the time is adjusted, the shake reminder will reset.

Basket light

Press the Light button will active both basket's light for 30 seconds.

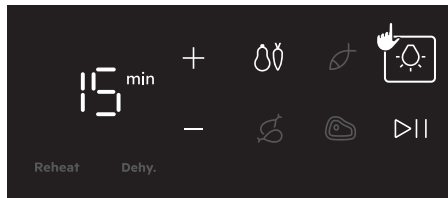

Note: Pulling out the cooking basket will trigger the corresponding basket light to turn on for 30 seconds.

When 30 seconds remain in the cooking time, the basket light will turn on.

When cooking is complete, the display panel will show "End" and the appliance will emit three beeps as a reminder.

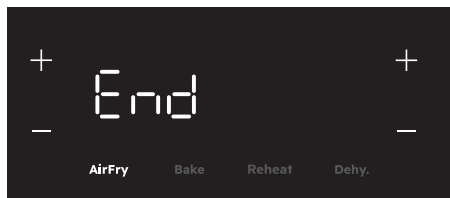

WARNING

- When removing the cooking basket, note that all parts except the handle are hot—do not touch them.
- When pulling out the handle, be careful to avoid steam release.

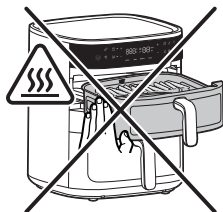

Usage of accessories(optional)

Cooking tongs

Silicone tongs can be used to:

- Press the ring at the top to release the cooking tongs.
- Put food into or take cooked food out of the fryer basket.
- Flip food during cooking.

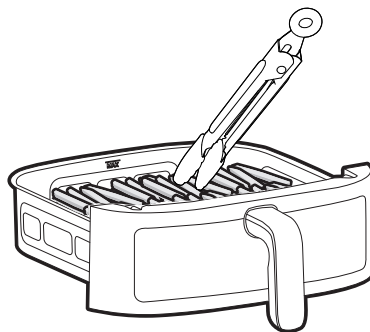
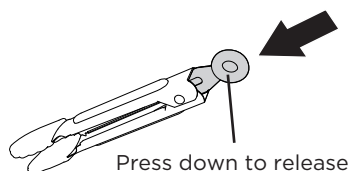

Wire Rack

This rack gives you an extra layer of space. You can either cook more different foods at once or layer the same type of food for more even heating.

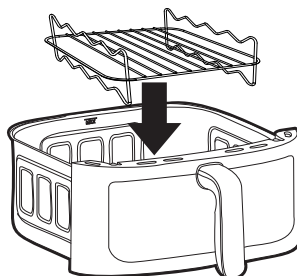

Note: Multi - layer rack can only fit on the bottom basket.

Error code

When below error codes show on the display, please contact your Authorized Frigidaire Service Center.

Error Code	Description
E1	Top bucket open circuit.
E2	Top bucket short circuit.
E3	Bottom bucket open circuit.
E4	Bottom bucket short circuit.
E5	Control PCBA communication failure.
E6	Power PCBA communication failure.

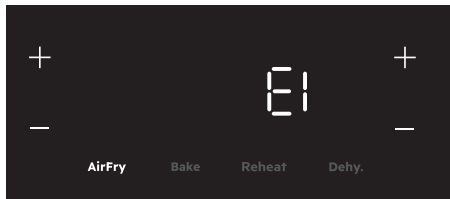

Preset Recipes

The adjustable ranges of temperature and time vary among different modes. Each time a different mode is selected, the temperature and time will be reset to the values in the preset recipe. Please select the appropriate mode according to the following introduction of the modes.

 **NOTE**

It is necessary to turn certain foods at halfway through the cooking time for uniform texture. Use gloves or tongs to ensure your safety and avoid accidents.

Recipes preset settings.

Mode	Preset Temp. (°F/°C)	Preset Time	Temp Range Possible (°F/°C)	Time Range	Shake Reminder (Y/N)
AirFry	360°F/180°C	25min	140-400°F/ 60-200°C	1-99min	Y
Bake	340°F/170°C	15min	140-400°F/ 60-200°C	1-99min	N
Reheat	320°F/160°C	7min	140-400°F/ 60-200°C	1-99min	N
Dehy.	175°F/80°C	5hours	100-175°F/ 40-80°C	1-5hours	N
Vegetables	340°F/170°C	15min	140-400°F/ 60-200°C	1-99min	Y
Fish	285°F/140°C	15min	140-400°F/ 60-200°C	1-99min	Y
Drumstick	360°F/180°C	30min	140-400°F/ 60-200°C	1-99min	Y
Steak	400°F/200°C	15min	140-400°F/ 60-200°C	1-99min	Y

 **IMPORTANT**

The temperature and preparation times listed in the table are guidelines and vary depending on the recipes and the amount of ingredients, shape and texture of the foods. You can adjust the cooking temperature and time as desired.

14 CARE & CLEANING

Cleaning

To avoid electric shock, remove the plug from the outlet before performing any cleaning or maintenance. Cleaning should be done with a cold appliance.

Cleaning the main unit

Use only a damp cloth to clean the outside of the appliance and its electrical cable.

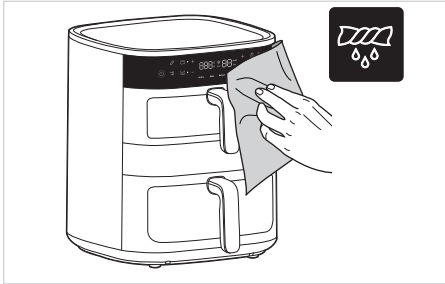

Use a dry soft-bristled brush to sweep loose food debris (like breadcrumbs) from the cavity. For oil stains, wipe with a slightly damp cloth/sponge dipped in warm soapy water (no harsh cleaners).

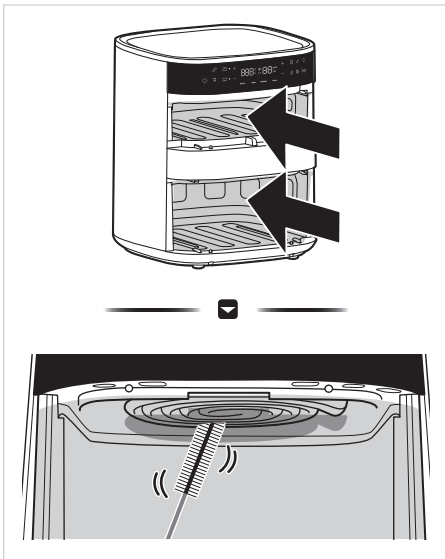

Cleaning the cooking baskets

Use a soft sponge and mild detergent and rinse thoroughly to clean the baskets. Baskets are also dishwasher safe. Clean the accessories only after they cool down.

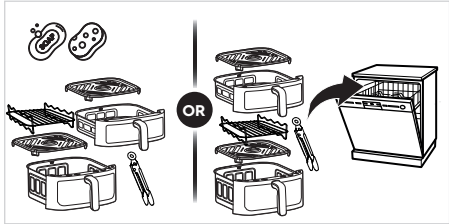

WARNING

- Never immerse the appliance, plug or power cord in water or any other liquid.
- Never clean your appliance with flammable fluids (e.g., alcohol, kerosene, gasoline, thinner, solvents, removers), chemicals (e.g., ammonia-based detergents, acids, vinegar, soda), or abrasive substances (e.g., soaps).
- Do not use steam equipment to clean the appliance.
- After cleaning, make sure the appliance is completely dry before operating it.

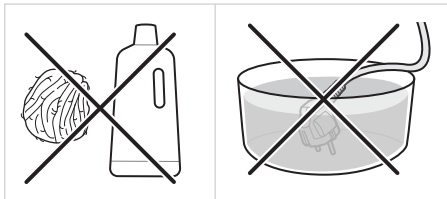

Storage

1. Turn off the appliance and allow it to cool completely.
2. Ensure that all components and accessories are clean and dry.
3. Store your appliance in a flat, dry, safe place away from children.

TROUBLESHOOTING 15

Use this guide to help with common issues that may interfere with the performance of the product. If this does not help improve the issue, please contact Customer Service.

Problem	Possible Cause	Solution
Appliance doesn't work	Appliance not plugged in.	Plug the mains plug into an earthed wall socket.
	Start button not pressed.	Press the Play/Pause button after setting temperature and time.
Fried ingredients are undercooked.	Too many ingredients in the basket.	Cook ingredients in smaller batches (for more even frying).
	Set temperature too low.	Adjust to the required temperature.
Ingredients fry unevenly.	Certain ingredients need shaking halfway through cooking.	Shake ingredients stacked/crossed (e.g., fries) halfway through cooking.
Can't slide the basket properly.	Too many ingredients in the basket.	Don't fill beyond the "MAX" mark on the basket.
White smoke comes out of the appliance.	Preparing greasy ingredients.	Oil may splatter onto the heating element, causing white smoke. This is normal.
	Grease residues left in the basket from previous use.	White smoke is caused by the heated grease residues in the basket. Thoroughly clean the basket after each use.
Fresh fries are fried unevenly.	Using the wrong type of potato.	Use fresh potatoes and ensure they remain firm during frying.
	Insufficient rinsing of potato sticks before frying.	Properly rinse the potato sticks to remove the starch from their surface.

Model	FRDA100B, FRDA110B, FRDA200BC, FRDA210BC
Voltage	120V
Frequency	60Hz
Power	1800W
Capacity	Top basket(4.2Qt) / Bottom basket(7.4Qt)
Color	Black

16 LIMITED WARRANTY

Your appliance is covered by a one year limited warranty. For one year from your original date of delivery, Electrolux will pay all costs for repairing or replacing any parts of this appliance that prove to be defective in materials or workmanship when such appliance is installed, used and maintained in accordance with the provided instructions.

Exclusions

This warranty does not cover the following:

1. Products with original serial numbers that have been removed, altered or cannot be readily determined.
2. Product that has been transferred from its original owner to another party or removed outside the USA or Canada.
3. Rust on the interior or exterior of the unit.
4. Products purchased "as-is" are not covered by this warranty.
5. Products used in a commercial setting.
6. Service calls which do not involve malfunction or defects in materials or workmanship, or for appliances not in ordinary household use or used other than in accordance with the provided instructions.
7. Service calls to correct the installation of your appliance or to instruct you how to use your appliance.
8. Expenses for making the appliance accessible for servicing, such as removal of trim, cupboards, shelves, etc., which are not a part of the appliance when it is shipped from the factory.
9. Service calls to repair or replace appliance light bulbs, air filters, other consumables, or knobs, handles, or other cosmetic parts.
10. Pickup and delivery costs; your appliance is designed to be repaired in the home.
11. Surcharges including, but not limited to, any after hour, weekend, or holiday service calls, tolls, ferry trip charges, or mileage expense for service calls to remote areas, including the state of Alaska.
12. Damages to the finish of appliance or home incurred during transportation or installation, including but not limited to floors, cabinets, walls, etc.
13. Damages caused by: services performed by unauthorized service companies; use of parts other than genuine Electrolux parts or parts obtained from persons other than authorized service companies; or external causes such as abuse, misuse, inadequate power supply, accidents, fires, or acts of God.

DISCLAIMER OF IMPLIED WARRANTIES; LIMITATION OF REMEDIES

CUSTOMER'S SOLE AND EXCLUSIVE REMEDY UNDER THIS LIMITED WARRANTY SHALL BE REPAIR OR REPLACEMENT AS PROVIDED HEREIN. CLAIMS BASED ON IMPLIED WARRANTIES, INCLUDING WARRANTIES OF MERCHANTABILITY OR FITNESS FOR A PARTICULAR PURPOSE, ARE LIMITED TO ONE YEAR OR THE SHORTEST PERIOD ALLOWED BY LAW, BUT NOT LESS THAN ONE YEAR. ELECTROLUX SHALL NOT BE LIABLE FOR CONSEQUENTIAL OR INCIDENTAL DAMAGES SUCH AS PROPERTY DAMAGE AND INCIDENTAL EXPENSES RESULTING FROM ANY BREACH OF THIS WRITTEN LIMITED WARRANTY OR ANY IMPLIED WARRANTY. SOME STATES AND PROVINCES DO NOT ALLOW THE EXCLUSION OR LIMITATION OF INCIDENTAL OR CONSEQUENTIAL DAMAGES, OR LIMITATIONS ON THE DURATION OF IMPLIED WARRANTIES, SO THESE LIMITATIONS OR EXCLUSIONS MAY NOT APPLY TO YOU. THIS WRITTEN WARRANTY GIVES YOU SPECIFIC LEGAL RIGHTS. YOU MAY ALSO HAVE OTHER RIGHTS THAT VARY FROM STATE TO STATE.

If You Need Service

Keep your receipt, delivery slip, or some other appropriate payment record to establish the warranty period should service be required. If service is performed, it is in your best interest to obtain and keep all receipts. Service under this warranty must be obtained by contacting Electrolux at the addresses or phone numbers below.

This warranty only applies in the USA, Puerto Rico and Canada. In the USA and Puerto Rico, your appliance is warranted by Electrolux Consumer Products, Inc. In Canada, your appliance is warranted by Electrolux Canada Corp. Electrolux authorizes no person to change or add to any obligations under this warranty. Obligations for service and parts under this warranty must be performed by Electrolux or an authorized service company. Product features or specifications as described or illustrated are subject to change without notice.

USA & Puerto Rico
1-800 374 4432
Electrolux Consumer Products, Inc.
10200 David Taylor Drive
Charlotte, NC 28262

FRIGIDAIRE

Canada
1-800 265 8352
Electrolux Canada Corp.
5855 Terry Fox Way
Mississauga, Ontario,
Canada L5V 3E4

FRIGIDAIRE®

welcome *home*

Our home is your home. Visit us if you need help with any of these things:



owner support



accessories



service



registration

(See your registration card for more information.)

Frigidaire.com
1-800-374-4432

Frigidaire.ca
1-800-265-8352