



**5.0 Horsepower
21 Inch Single Stage
Auger Propelled
Electric Start
SNOW THROWER**

**MODEL NO.
536.885212**



Caution:

**Read and follow all Safety Rules
and Operating Instructions before
first use of this product.**

**SEARS, ROEBUCK AND CO., Hoffman Estates, IL 60179 U.S.A.
F-001128M**

SAFETY

ASSEMBLY

OPERATION

MAINTENANCE

PARTS LIST

ESPAÑOL

TABLE OF CONTENTS

WARRANTY STATEMENT	2	STORAGE	20
SAFETY RULES	2	TROUBLE SHOOTING CHART ..	21
INTERNATIONAL SYMBOLS	4	REPAIR PARTS	22
ASSEMBLY	6	ENGINE REPAIR PARTS	32
OPERATION	8	SPANISH (ESPAÑOL)	38
MAINTENANCE	14	PARTS ORDERING/SERVICE ..	60
SERVICE AND ADJUSTMENT ..	16		

WARRANTY STATEMENT

LIMITED TWO-YEAR WARRANTY ON CRAFTSMAN SNOW THROWER

For two years from the date of purchase, when this Craftsman Snow thrower is maintained, lubricated, and tuned up according to the operating and maintenance instructions in the owner's manual, Craftsman will repair, free of charge, any defect in material or workmanship.

If this Craftsman Snow thrower is used for commercial or rental purposes, this warranty applies for only 90 days from the date of purchase.

This warranty does not cover the following:

- Items which become worn during normal use, such as spark plugs, drive belts and shear pins.
- Repair necessary because of operator abuse or negligence, including bent crankshafts and the failure to maintain the equipment according to the instructions contained in the owner's manual.

WARRANTY SERVICE IS AVAILABLE BY RETURNING THE CRAFTSMAN SNOW THROWER TO THE NEAREST CRAFTSMAN SERVICE CENTER/DEPARTMENT IN THE UNITED STATES. THIS WARRANTY APPLIES ONLY WHILE THIS PRODUCT IS IN USE IN THE UNITED STATES.

This warranty gives you specific legal rights, and you may also have other rights which may vary from state to state.

Sears, Roebuck and Co., D817WA, Hoffman Estates, IL 60179

SAFETY RULES



LOOK FOR THIS SYMBOL TO POINT OUT IMPORTANT SAFETY PRECAUTIONS. IT MEANS— ATTENTION!!! BECOME ALERT!!! YOUR SAFETY IS INVOLVED.



WARNING:



Engine Exhaust, some of its constituents, and certain vehicle components contain or emit chemicals known to the State of California to cause cancer and birth defects or other reproductive harm.

Battery posts, terminals and related accessories contain lead and lead compounds, chemicals known to the State of California to cause cancer and birth defects or other reproductive harm. **WASH HANDS AFTER HANDLING.**



WARNING: Always disconnect the spark plug wire and place it where it cannot make contact with spark plug to prevent accidental starting during: Preparation, Maintenance, or Storage of your snow thrower.

IMPORTANT: Safety standards require operator presence controls to minimize the risk of injury. Your snow thrower is equipped with such controls. Do not attempt to defeat the function of the operator presence control under any circumstances.

TRAINING

1. Read the operating and service instruction manual carefully. Be thoroughly familiar with the controls and the proper use of the equipment. Know how to stop the unit and disengage the controls quickly.
2. Never allow children to operate the equipment. Never allow adults to operate the equipment without proper instruction.
3. Keep the area of operation clear of all persons, particularly small children and pets.
4. Exercise caution to avoid slipping or falling especially when operating in reverse.

PREPARATION

1. Thoroughly inspect the area where the equipment is to be used and remove all doormats, sleds, boards, wires, and other foreign objects.
2. Disengage all clutches before starting the engine (motor).
3. Do not operate the equipment without wearing adequate winter outer garments. Wear footwear that will improve footing on slippery surfaces.
4. Handle fuel with care; it is highly flammable.
 - a. Use an approved fuel container.
 - b. Never remove fuel tank cap or add fuel to a running engine (motor) or hot engine (motor).
 - c. Fill fuel tank outdoors with extreme care. Never fill fuel tank indoors.
 - d. Replace fuel cap securely and wipe up spilled fuel.
 - e. Never store fuel or snow thrower with fuel in the tank inside of a building where fumes may reach an open flame or spark.
 - f. Check fuel supply before each use, allowing space for expansion as the heat of the engine (motor) and/or sun can cause fuel to expand.
5. For all units with electric starting motors use electric starting extension cords certified CSA/UL. Use only with a receptacle that has been installed in accordance with local inspection authorities.
6. Adjust the snow thrower height to clear gravel or crushed rock surface.
7. Never attempt to make any adjustments while the engine (motor) is running (except when specifically recommended by manufacturer).
8. Let engine (motor) and snow thrower adjust to outdoor temperatures before starting to clear snow.

9. Always wear safety glasses or eye shields during operation or while performing an adjustment or repair to protect eyes from foreign objects that may be thrown from the snow thrower.

OPERATION

1. Do not operate this machine if you are taking drugs or other medication which can cause drowsiness or affect your ability to operate this machine.
2. Do not use this machine if you are mentally or physically unable to operate this machine safely.
3. Do not put hands or feet near or under rotating parts. Keep clear of the discharge opening at all times.
4. Exercise extreme caution when operating on or crossing gravel drives, walks or roads. Stay alert for hidden hazards or traffic.
5. After striking a foreign object, stop the engine (motor), remove the wire from the spark plug, thoroughly inspect snow thrower for any damage, and repair the damage before restarting and operating the snow thrower.
6. If the unit should start to vibrate abnormally, stop the engine (motor) and check immediately for the cause. Vibration is generally a warning of trouble.
7. Stop the engine (motor) whenever you leave the operating position, before unclogging the auger/impeller housing or discharge chute and when making any repairs, adjustments, or inspections.
8. When cleaning, repairing, or inspecting, make certain the auger/impeller and all moving parts have stopped and all controls are disengaged. Disconnect the spark plug wire and keep the wire away from the spark plug to prevent accidental starting.
9. Take all possible precautions when leaving the snow thrower unattended. Disengage the auger/impeller, stop engine (motor), and remove key.
10. Do not run the engine (motor) indoors, except when starting the engine (motor) and for transporting the snow thrower in or out of the building. Open the outside doors; exhaust fumes are dangerous (containing CARBON MONOXIDE, an ODORLESS and DEADLY GAS).
11. Do not clear snow across the face of slopes. Exercise extreme caution when changing direction on slopes. Do not attempt to clear steep slopes.
12. Never operate the snow thrower without proper guards, plates or other safety protective devices in place.

13. Never operate the snow thrower near enclosures, automobiles, window wells, drop-offs, and the like without proper adjustment of the snow discharge angle. Keep children and pets away.
14. Do not overload the machine capacity by attempting to clear snow at too fast a rate.
15. Never operate the machine at high transport speeds on slippery surfaces. Look behind and use care when backing up.
16. Never direct discharge at bystanders or allow anyone in front of the unit.
17. Disengage power to the collector/impeller when snow thrower is transported or not in use.
18. Use only attachments and accessories approved by the manufacturer of the snow thrower (such as tire chains, electric start kits, ect.).
19. Never operate the snow thrower without good visibility or light. Always be sure of your footing and keep a firm hold on the handles. Walk; never run.
20. Do not over-reach. Keep proper footing and balance at all times.
21. Do not attempt to use snow thrower on a roof.

MAINTENANCE AND STORAGE

1. Check shear bolts and other bolts at frequent intervals for proper tightness to be sure the equipment is in safe working condition.
2. Never store the snow thrower with fuel in the tank inside a building where ignition sources are present such as hot water and space heaters, clothes dryers, and the like. Allow the engine (motor) to cool before storing in any enclosure.
3. Always refer to operator's guide instructions for important details if the snow thrower is to be stored for an extended period.
4. Maintain or replace safety and instruction labels, as necessary.
5. Run the snow thrower a few minutes after throwing snow to prevent freeze-up of the auger/impeller.



WARNING: This snow thrower is for use on sidewalks, driveways and other ground level surfaces.

Caution should be exercised while using on steep sloping surfaces. **DO NOT USE SNOW THROWER ON SURFACES ABOVE GROUND LEVEL** such as roofs of residences, garages, porches or other such structures or buildings.

SYMBOLS

IMPORTANT: Many of the following symbols are located on your unit or on literature supplied with the product. Before you operate the unit, learn and understand the purpose for each symbol.

Control And Operating Symbols



Slow



Fast



Electric Start



Engine Start



Engine Run



Engine Off



Engine Stop



On



Choke Off



Choke On



Neutral



Throttle



Primer Button

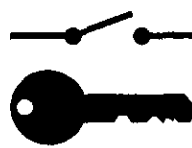

Ignition Key



Ignition Off

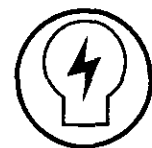

Ignition On

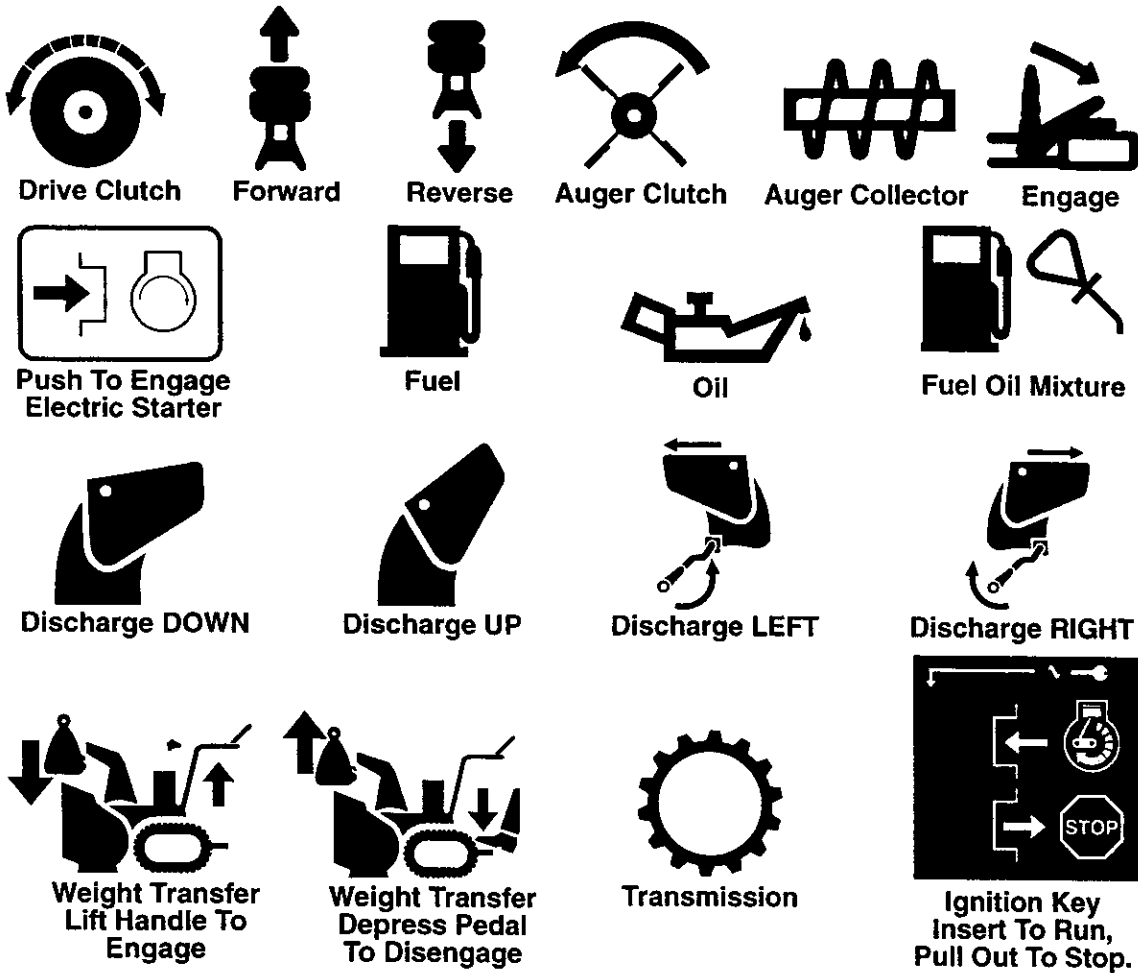

Drive Clutch

Forward

Reverse

Auger Clutch

Auger Collector

Engage

Push To Engage
Electric Starter

Fuel

Oil

Fuel Oil Mixture

Discharge DOWN

Discharge UP

Discharge LEFT

Discharge RIGHT

Weight Transfer
Lift Handle To
Engage

Weight Transfer
Depress Pedal
To Disengage

Transmission

Ignition Key
Insert To Run,
Pull Out To Stop.

Safety Warning Symbols



ASSEMBLY

Contents of Parts Bag

- 1 – Owner's Manual (not shown)
- 1 – Electric Starter Cord (not shown)



1– Container 3.2 ounce
Craftsman 2–cycle oil



WARNING: Always wear safety glasses or eye shields while assembling snow thrower.

TOOLS REQUIRED

- 1 – Knife to cut carton

Figure 1 shows the snow thrower in the operating position.

References to the right or left hand side of the snow thrower are from the viewpoint of the operator's position behind the unit.

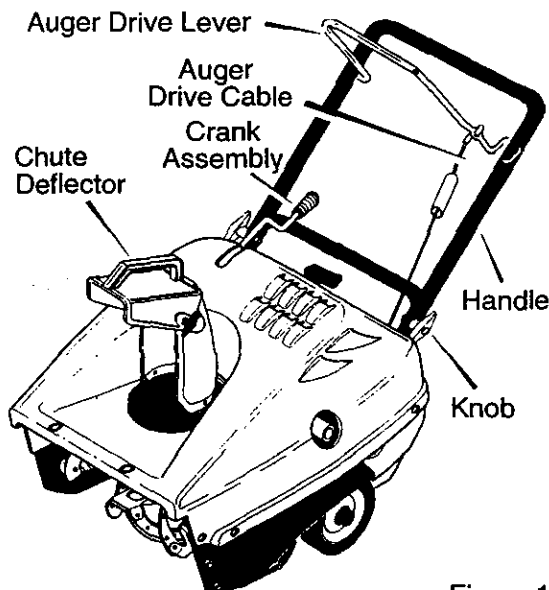

Figure 1

HOW TO REMOVE FROM THE CARTON

1. Locate and remove container of Craftsman 2–cycle oil.
2. Locate all parts packed separately and remove from the carton.
3. Remove and discard the packing material from around the snow thrower.
4. Cut down all four corners of the carton and lay the panels flat.
5. Hold onto the lower handle and pull the snow thrower off the carton.
CAUTION: DO NOT back over cables.
6. Remove the packing material from the handle assembly.

How To Assemble The Handle

1. Loosen the **knobs** on each side of the **handle** (Figure 1).
2. Raise the upper **handle** to the operating position. Hold the upper **handle** apart to prevent scratching the lower handle.
NOTE: Make sure the cables are not caught between the upper and lower handle.
3. Tighten the **knobs**.

ASSEMBLY

✓ CHECKLIST

Before you operate your new snow thrower, to ensure that you receive the best performance and satisfaction from this quality product, please review the following checklist:

- ✓ All assembly instructions have been completed.
- ✓ The discharge chute rotates freely.
- ✓ No remaining loose parts in carton.

While learning how to use your snow thrower, pay extra attention to the following important items:

- ✓ Make sure the fuel tank is filled with the correct mixture (40:1 ratio) of gasoline and oil.
- ✓ Become familiar with the location of all controls and understand their function.
- ✓ Before starting the engine, make sure all controls operate correctly.

PRODUCT SPECIFICATIONS

Horse Power:	5
Displacement:	8,46 cu. in.
Fuel Tank:	1,62 quart
Fuel/Oil Mixture:	40:1 Ratio 3,2 ounces of air cooled engine 2-cycle oil specified for 40:1 per 1 gallon of gasoline.
Spark Plug:	Champion RCJ8Y or equivalent (Gap 0.030)

OPERATION

KNOW YOUR SNOW THROWER

READ THIS OWNER'S MANUAL AND SAFETY RULES BEFORE OPERATING YOUR SNOW THROWER. Compare the illustrations with your SNOW THROWER to familiarize yourself with the location of various controls and adjustments. Save this manual for future reference.

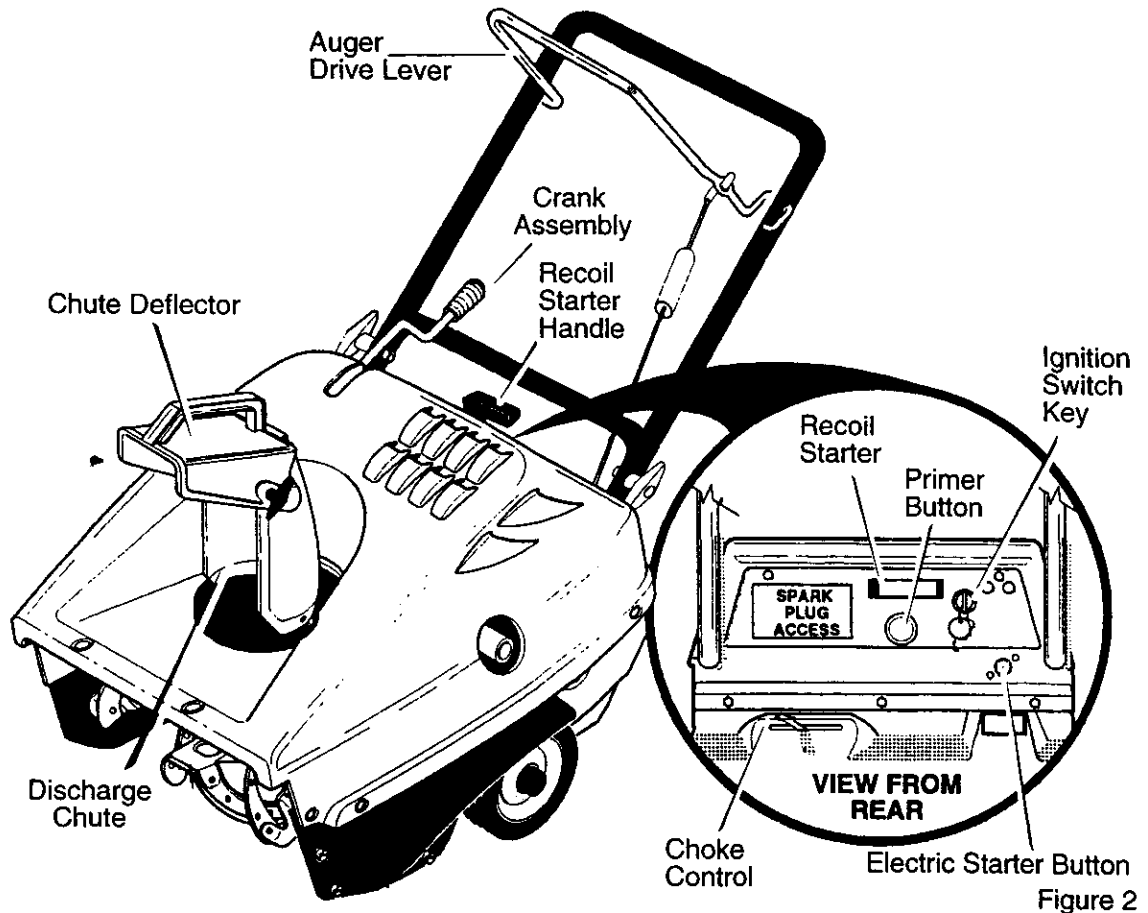

Figure 2

Auger Drive Lever – Starts and stops the auger.

Crank Assembly – Changes the direction of snow throwing through the discharge chute.

Chute Deflector – Changes the distance the snow is thrown.

Discharge Chute – Changes the direction the snow is thrown.

Ignition Switch Key – Must be inserted and turned to the ON position to start the engine.

Recoil Starter Handle – Starts the engine manually.

Electric Starter Button – Use to start the engine when using the 120V electric starter.

Choke Control – Used to start a cold engine.

Primer Button – Injects fuel directly into the carburetor manifold for fast starts in cold weather.

Spark Plug Access Panel – Aides in the removal of the spark plug.

OPERATION

The operation of any snow thrower can result in foreign objects being thrown into the eyes, which can result in severe eye damage. Always wear safety glasses or eye shields while operating the snow thrower.

We recommend standard safety glasses or a wide vision safety mask for over your glasses.



WARNING: Read Owner's Manual before operating machine. Never direct discharge toward bystanders stop the engine before unclogging discharge chute or auger housing and before leaving the machine.

TO STOP YOUR SNOW THROWER

1. To stop throwing snow, release the **auger drive lever**. See Figure 2.
NOTE: If the snow thrower continues to slowly move forward, see "How To Adjust The Auger Control Cable" in the Service And Adjustment Section.
2. To stop the engine, move the ignition key to the off position.

TO CONTROL SNOW DISCHARGE

1. Turn the chute control rod to set the direction of the snow throwing.
2. Loosen the **wing knob** on the chute deflector and move the deflector to set the distance. Move the deflector (**Up**) for more distance, (**Down**) for less distance. Then tighten the **wing knob** (See Figure 3).

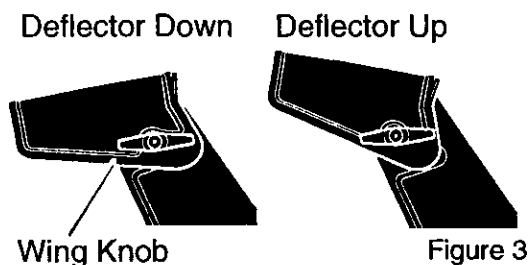

F-001128M

HOW TO THROW SNOW

1. Engage the **auger drive lever**.
2. To stop throwing snow, release the **auger drive lever**.



WARNING: The operation of any snow thrower can result in foreign objects being thrown into the eyes, which can result in severe eye damage. Always wear safety glasses or eye shields while operating the snow thrower. We recommend standard safety glasses or use a wide vision safety mask over your glasses.

HOW TO MOVE FORWARD

1. Hold the **auger drive lever** against the **handle** (See Figure 4). The auger will begin rotating.
2. To go forward, raise the **handle** to allow the **rubber auger blades** to contact the ground. Maintain a firm hold on the **handle** as the snow thrower starts to move forward. Guide the snow thrower by moving the **handle** either left or right. Do not attempt to push the snow thrower.
3. To stop, release the **auger drive lever**.

NOTE: If the auger continues to rotate, see "How To Adjust The Auger Control Cable" in the Service and Adjustments section.

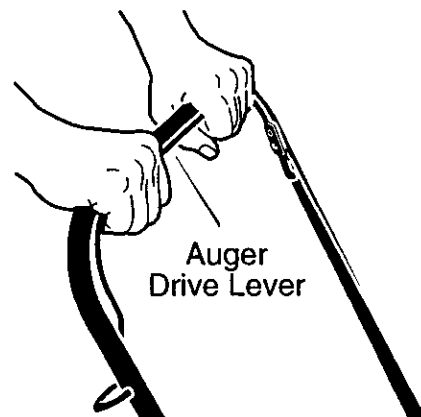

Figure 4

OPERATION

FILL GAS:

NOTICE: ENGINES WHICH ARE CERTIFIED TO COMPLY WITH CALIFORNIA AND US EPA EMISSION REGULATIONS FOR ULGE ENGINES: Are certified to operate on regular unleaded gasoline. Include the following emission control system(s): EM, TWC (if so equipped). Include any user adjustable features—therefore no other adjustments are needed.



WARNING: Experiences indicate that alcohol blended fuels (called gasohol or those using ethanol or methanol) can attract moisture which leads to separation and formation of acids during storage. Acidic gas can damage the fuel system of an engine while in storage.

NOTE: To avoid engine problems, the fuel system must be emptied before storage for 30 days or longer. Start the engine and let it run until the fuel lines and carburetor are empty. Use the carburetor bowl drain to empty residual gasoline from the float chamber. Use fresh fuel next season. See the **Storage** section in this manual for additional information.

Never use engine or carburetor cleaner products in the fuel tank or permanent damage may occur.

HOW TO MIX THE FUEL MIXTURE

The two cycle engine, used on this snow thrower, requires a mixture of gasoline and oil for lubrication of the bearings and other moving parts. The correct fuel mixture ratio is 40:1 (3.2 oz. oil per one gallon of gas – see the Fuel Mixture Chart). Gasoline and oil must be pre-mixed in a clean gasoline container. Always use fresh, clean, unleaded gasoline.

FUEL MIXTURE CHART (mixture 40:1)

U.S.		IMPERIAL		SI. (Metric)	
GAS	OIL	GAS	OIL	GAS	OIL
1 Gal.	3.2 oz	1 Gal.	3.7 oz	4 liter	100 ML

Mix gasoline and oil as follows:

1. Pour one (1) U.S. quart of fresh, clean, unleaded automotive gasoline into a one gallon size gasoline container.
2. Add 3.2 ounces of clean, high quality, two-cycle oil to the gasoline container.

IMPORTANT: Do not use outboard motor oil or multi-viscosity oils, such as 10W-30 or 10W-40.

3. Install the fuel cap onto the gasoline container. Vigorously shake the gasoline container to mix the oil with the gasoline.
4. Add an additional three (3) U.S. quarts of gasoline to the gallon container. Again shake the gasoline container.

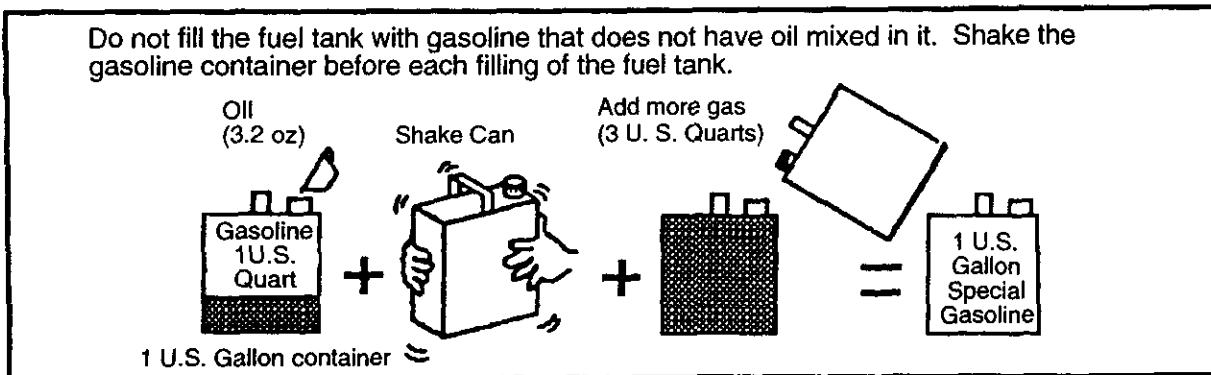

OPERATION



WARNING: Gasoline is flammable. Always use caution when handling or storing

gasoline.

Do not fill fuel tank while snow thrower is running, when it is hot, or when snow thrower is in an enclosed area.

Keep away from open flame or an electrical spark and do not smoke while filling the fuel tank.

Never fill the tank completely. Fill the tank to within 1/4"–1/2" from the top to provide space for expansion of fuel.

Always fill fuel tank outdoors and use a funnel or spout to prevent spilling.

Make sure to wipe up any spilled fuel before starting the engine.

Store gasoline in a clean, approved container and keep the cap in place on the container.



WARNING: The starter is equipped with a three-wire power cord and plug and is designed to operate on 120 volt A.C. household current. The power cord must be properly grounded at all times to avoid the possibility of electrical shock which can injure the operator. Carefully follow all instructions in the "How To Start The Engine" section. Make sure that your house wiring is a three-wire grounded system. If you are not sure, ask a licensed electrician. If your house wire system is not a three-wire grounded system, do not use this electric starter under any conditions. If your system is grounded but a three-hole grounded receptacle is not available to start the engine, have a three-hole grounded receptacle installed by a licensed electrician. To connect a 120 volt A.C. power cord, always connect the power cord to the switch box on the engine first. Then, plug the other end into the three-hole grounded receptacle. When disconnecting the power cord, always unplug the end from the three-hole grounded receptacle first.

BEFORE STARTING THE ENGINE

1. Before you service or start the engine, familiarize yourself with the snow thrower. Be sure you understand the function and location of all controls.
2. Be sure that all fasteners are tight.
3. Before starting the engine, make sure all controls operate correctly.

HOW TO STOP THE ENGINE

To stop the engine, move the ignition key to the stop position.

HOW TO START THE ENGINE

The engine is equipped with a 120 volt AC electric starter and also a recoil starter. Before starting the engine, make certain that you have read the following information.

F-001128M

HOW TO START A COLD ENGINE

1. Fill the fuel tank with a fresh, clean fuel mixture. See "How To Mix The Fuel Mixture".
2. Move the choke control to FULL position.
3. Make sure the **auger drive lever** is in the disengaged (released) position.
4. Insert the **ignition key** and turn to the ON position.
5. Move the **choke control** to the full choke position.
6. **(Electric Start)** Connect the power cord to the **switch box** located on the engine.
7. **(Electric Start)** Plug the other end of the power cord into a three-hole,

OPERATION

grounded 120 VOLT, A.C. receptacle. (See the WARNING in this section).

8. Push the **primer button** while covering the vent hole as follows: Remove finger from primer button between primes.
Do not prime if temperature above 50° F (10° C).
Push two time if temperature is 50° F (10° C) to 15°F (-10° C).
Push four times if temperature is below 15° F (-10° C).
Push five time if temperature is below 0° F (-18° C).
9. **(Electric Start)** Push on the **electric start button** until the engine starts. Do not crank for more than 10 seconds at a time. The electric starter is thermally protected. If the electric starter overheates, it will automatically stop and can only be restarted when it has cooled to a safe temperature. A wait of about 5 to 10 minutes is required to allow the electric starter to cool.
10. **(Recoil Start)** Rapidly pull the **recoil starter handle**. Do not allow the **recoil starter handle** to snap back. Slowly return the **recoil starter handle**.
11. If the engine does not start in 5 or 6 tries, See the "Trouble Shooting Chart" Instructions.
12. **(Electric Start)** When the engine starts, release the **electric start button**.
13. **(Electric Start)** First disconnect the power cord from the three-hole receptacle. Then, disconnect the power cord from the **switch box**.
14. As the engine warms up, move the **choke control** to 1/2 choke posi-

tion. When the engine runs smoothly, move the **choke control** to the off position.

NOTE: Allow the engine to warm up for several minutes before blowing snow in temperatures below 0°F.

WARM START

If restarting a warm engine after a short shutdown, leave choke at "OFF" and do not push the primer button. If the engine fails to start, follow the Cold Start instructions.



WARNING: Never run engine indoors or in enclosed, poorly ventilated areas. Engine exhaust contains **CARBON MONOXIDE, AN ODORLESS AND DEADLY GAS**. Keep hands, feet, hair and loose clothing away from any moving parts on engine and snow thrower.

The temperature of muffler and nearby areas may exceed 150°F. Avoid these areas.

DO NOT allow children or young teenagers to operate or be near snow thrower while it is operating.



WARNING: Do not attempt to remove any item that may become lodged in auger without taking the following precautions:

- Release auger drive lever.
- Move the ignition lever to the stop position to stop the engine.
- Disconnect spark plug wire.
- Do not place your hands in the auger or discharge chute. Use a pry bar.

OPERATION

SNOW THROWING TIPS

1. When the handle is raised, the auger blades will engage the ground and the snow thrower will move forward. When the auger drive lever is released, the auger blades will stop. If the blades do not stop, see "How To Adjust The Auger Drive Cable" in the Service And Adjustment section.
2. Most efficient snow throwing is accomplished when the snow is removed immediately after it falls.
3. For complete snow removal, slightly overlap each previous path.
4. Whenever possible, discharge the snow down wind.
5. The distance the snow will be discharged can be adjusted by moving the discharge chute deflector. Raise the deflector for more distance or lower the deflector for less distance.
6. In windy conditions, lower the chute deflector to direct the discharged snow close to the ground where it is less likely to blow into unwanted areas.
7. For safety and to prevent damage to the snow thrower, keep the area to be cleared free of stones, toys and other foreign objects.
8. Do not use the auger propelling feature when clearing gravel or crushed rock driveways. Move the handle down to slightly raise the auger.
9. The forward speed of the snow thrower is dependent on the depth and weight of the snow. Experience will establish the most effective method of using the snow thrower under different conditions.

10. After each snow throwing job, allow the engine to run for a few minutes. The snow and accumulated ice will melt off the engine.
11. Clean the snow thrower after each use.
12. Remove ice, snow and debris from the entire snow thrower. Flush with water to remove all salt or other chemicals. Wipe snow thrower dry.

DRY AND AVERAGE SNOW

1. Snow up to eight inches deep can be removed rapidly and easily by walking at a moderate rate. For snow or drifts of a greater depth, slow your pace to allow the discharge chute to dispose of the snow as rapidly as the auger receives the snow.
2. Plan to have the snow discharged in the direction the wind is blowing.

WET PACKED SNOW

Move slowly into wet, packed snow. If the wet, packed snow causes the auger to slow down or the discharge chute begins to clog, back off and begin a series of short back and forth jabs into the snow. These short back and forth jabs, four to six inches, will "belch" the snow from the chute.

SNOW BANKS AND DRIFTS

In snow of greater depth than the unit, use the same "jabbing" technique described above. Turn the discharge chute away from the snow bank. More time will be required to remove snow of this type than level snow.

MAINTENANCE

CUSTOMER RESPONSIBILITIES

SERVICE RECORDS Fill in dates as you complete regular service.	Before Each Use	Often	Every 5 Hours	Every 10 Hours	Every 25 Hours	Each Season	Before Storage	SERVICE DATES
Tighten All Screws and Nuts	√	√						
Check Spark Plug					√	√		
Lubricate Chute Control Flange							√	
Drain Fuel							√	
Check Fuel	√							
Check Auger Drive Cable Adjustment (See Cable Adjustment)						√		

GENERAL RECOMMENDATIONS

The warranty on this snow thrower does not cover items that have been subjected to operator abuse or negligence. To receive full value from the warranty, the operator must maintain the snow thrower as instructed in this manual.

Some adjustments will need to be made periodically to properly maintain your snow thrower.

All adjustments in the **Service and Adjustments** section of this manual should be checked at least once each season.

AFTER EACH USE

- Check for any loose or damaged parts.
- Tighten any loose fasteners.
- Check and maintain the auger.
- Check controls to make sure they are functioning properly.
- If any parts are worn or damaged, replace immediately.
- Run the machine to clear the auger of snow.

- To prevent freezing of the auger or controls, remove all snow and slush from the snow thrower.

LUBRICATION

Before Storage

1. Remove the **top cover**. See "How To Remove The Top Cover".
2. Lubricate the **chute control flange**. Apply a clinging type of grease such as Lubriplate.

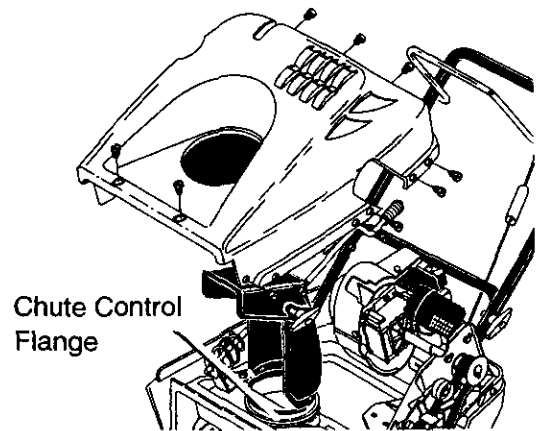

Figure 5

MAINTENANCE

HOW TO REMOVE THE TOP COVER

1. Remove the **discharge chute**.
2. Remove the **fuel cap**.
3. Remove the two **bolts and nuts (A)** from the front of the **top cover**.
4. Remove the two **bolts (B)** from the left and right side of the **top cover**.
5. Remove the eight **screws (C)** on the left and right side of the **top cover**.
6. Remove the three **screws (D)** from the top portion of the **control panel**.
7. Carefully pull the rear of the **top cover** up and over the **gas tank**.
8. To install the **top cover**, reverse the above steps.

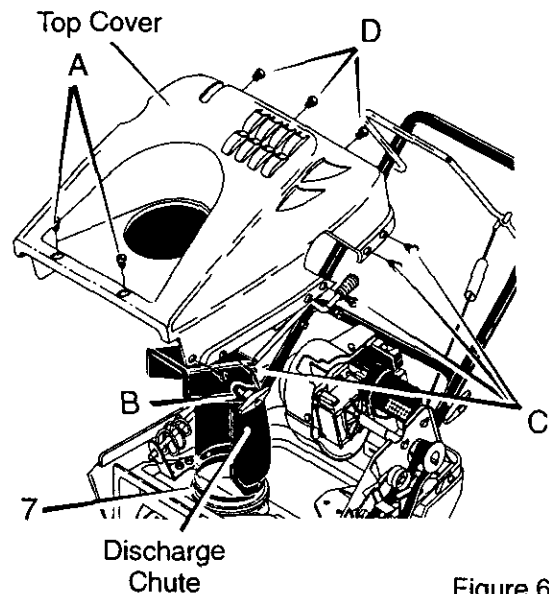

Figure 6

HOW TO REMOVE THE BELT COVER

1. If equipped, remove the **heat shield** from the rear of the **belt cover**.
2. Remove the **bolts and nuts (A)** that hold the **belt cover** to the **auger housing**.
3. If the top cover has not been removed, then remove the **screws (B)** that attach the **belt cover** to the **top cover**.
4. Remove **screw (C)** that holds the **belt cover** to the **bottom cover**.
5. To remove, hold the bottom portion of the **belt cover** and pull down and out.
6. To install the **belt cover**, reverse the above steps.

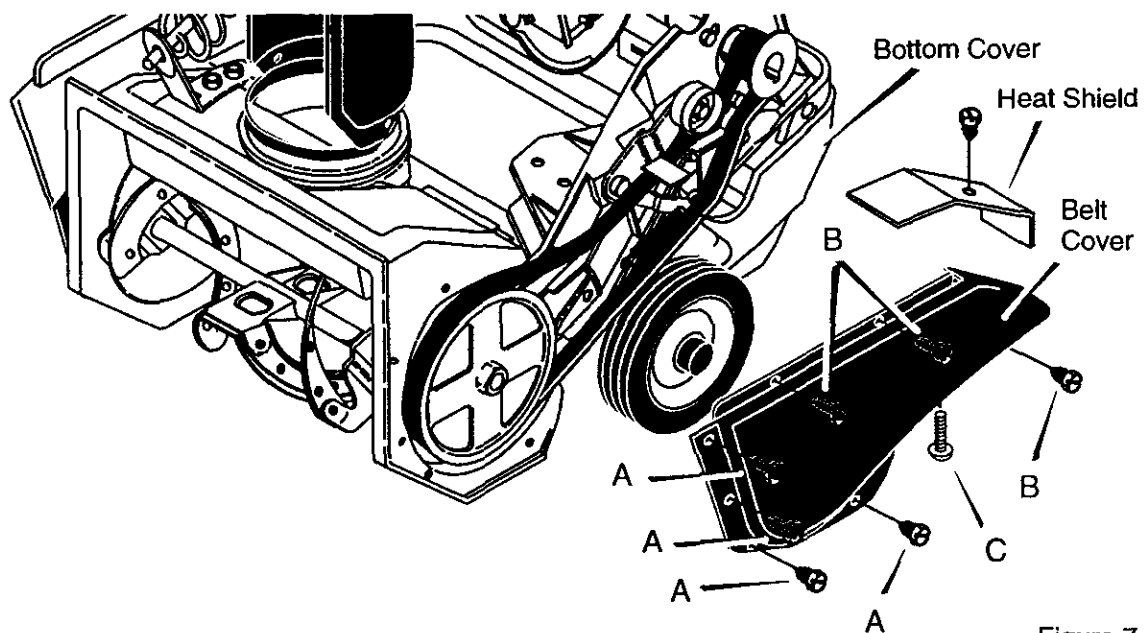

Figure 7

SERVICE AND ADJUSTMENT



WARNING: To prevent accidental starting when making any adjustments or repairs, always disconnect the spark plug wire and place it where it cannot make contact with the spark plug.

HOW TO ADJUST THE CHUTE CRANK

If the chute crank will not rotate fully to the left or right, adjust as follows.

1. Remove the top cover. See "How To Remove The Top Cover".
2. Loosen the nuts.
3. Move the **crank adjusting bracket** to allow **1/8 inch (3mm)** clearance between the notch in the **flange** and

- the outer diameter of the **worm gear**.
4. Tighten the nuts.

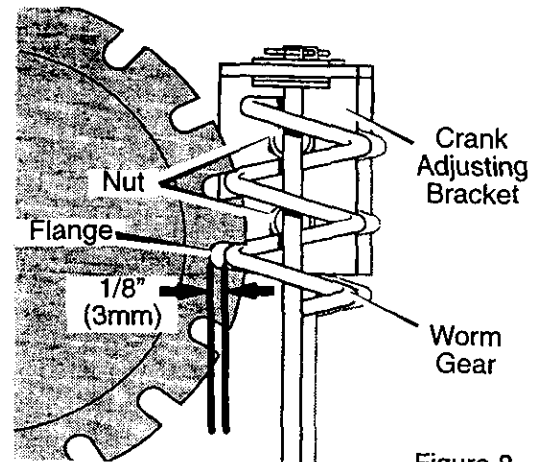

Figure 8

HOW TO ADJUST THE AUGER CONTROL CABLE

The auger control cable is adjusted at the factory. During normal use, the auger control cable can become stretched and the auger drive lever will not properly engage or disengage the auger.

1. Remove the "Z" hook from the **auger drive lever** (Figure 9).
2. Slide the **cable boot** off the **cable adjustment bracket** (Figure 10).
3. Push the bottom of the **auger control cable** through the **cable adjustment bracket** until the "Z" hook can be removed.
4. Remove the "Z" hook from the **cable adjustment bracket**. Move the "Z" hook down to the next adjustment hole.
5. Pull the **auger control cable** up through the **cable adjustment bracket**.
6. Put the **cable boot** over the **cable adjustment bracket**.
7. Install the "Z" hook to the **auger drive lever**.

8. To check the adjustment, start the snow thrower. Make sure the auger does not rotate when the auger drive lever is released.

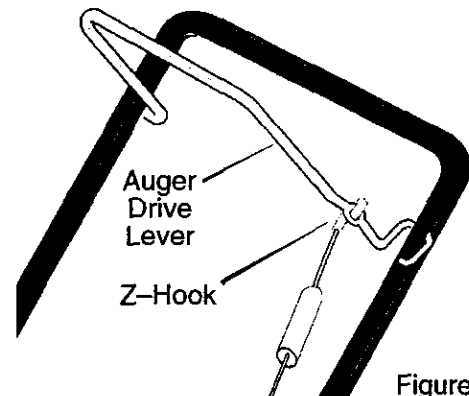

Figure 9

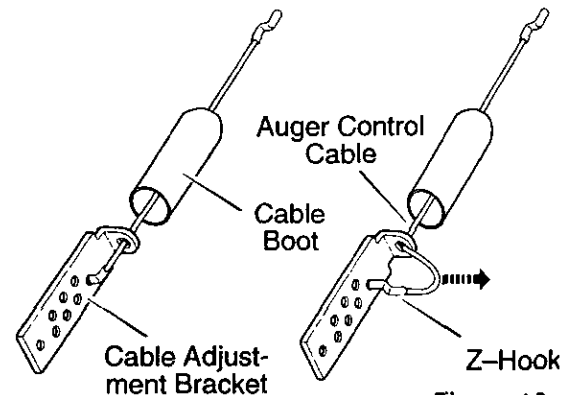

Figure 10

SERVICE AND ADJUSTMENT

HOW TO REPLACE THE DRIVE BELT

The drive belt is of special construction and must be replaced with original factory replacement belt available from your nearest Sears authorized service center.

1. Remove the belt cover. See "How To Remove The Belt Cover".
2. Remove the **drive belt** from the **idler pulley** (Figure 11).
3. Move the **belt guide** away from the belt.
4. To reduce pressure on the drive belt, move the idler pulley away from the belt. Remove the drive belt from between the brake pad and the roller.
5. Remove the old **drive belt**.
6. To install the new **drive belt**, reverse the above steps.
7. Make sure the **drive belt** is seated properly on the pulleys.
8. Set the belt guide to $3/32$ " clearance as shown in Figure 12.

NOTE: When the auger control lever is engaged, the belt guide must be $3/32$ " from the drive belt.

9. Install belt cover. See "How To Remove The Belt Cover".

HOW TO REPLACE THE AUGER

1. Remove the belt cover. See "How To Remove The Belt Cover".
2. Remove the drive belt. See "How To Replace The Drive Belt".
3. Remove the **auger pulley (1)** from the auger shaft (threads are left hand; turn clockwise to remove).
4. To keep the auger from rotating, set a 2"x4" piece of wood on the center paddle to secure auger.
5. Remove the fasteners from the **bearing assembly**. Remove the **bearing assembly** from the **auger housing**.
6. Slide the **auger** out of the bearing assembly on the right side of the snow thrower.

7. Tip the **auger** enough to allow the **auger** to slide out of the **auger housing**.
8. To install **auger**, reverse the above steps.

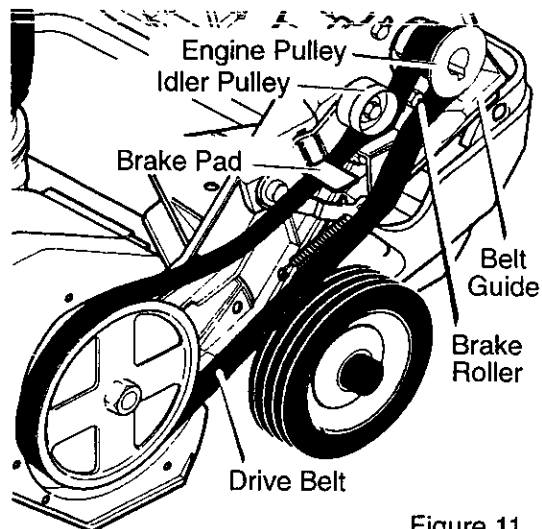

Figure 11

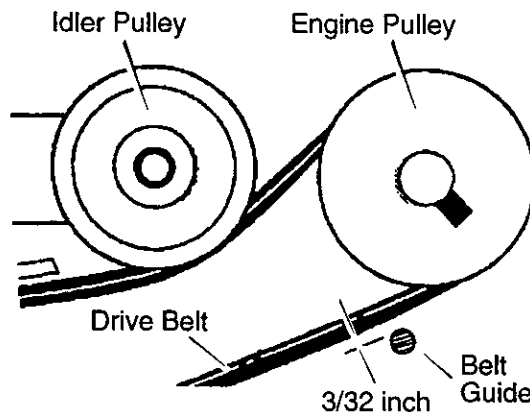

Figure 12

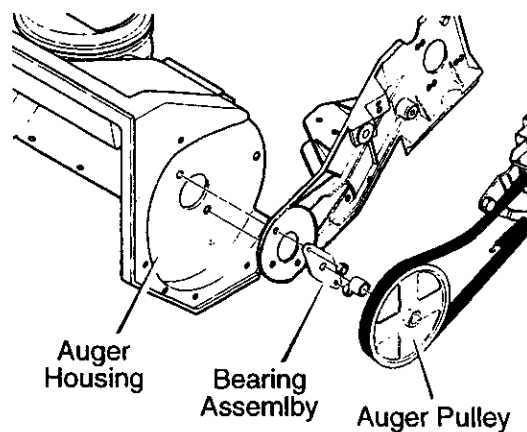

Figure 13

SERVICE AND ADJUSTMENT

HOW TO ADJUST THE BRAKE PAD

The brake pad is adjusted at the factory and a periodic adjustment is not necessary.

IMPORTANT: An adjustment is only necessary if the brake pad has become loose or has been removed. To adjust, proceed as follows:

1. Remove the top cover. See "How To Remove The Top Cover".
2. Remove the belt cover. See "How To Remove The Belt Cover".
3. Tie the auger drive lever to the handle. This will engage the drive system.
4. Loosen the **screw** and nut on the **brake pad arm** (Figure 14).
5. Set the clearance between the **brake pad** and the **drive belt** to **1/8 inch**.
6. Tighten the **screw** and nut on the **brake pad arm**.

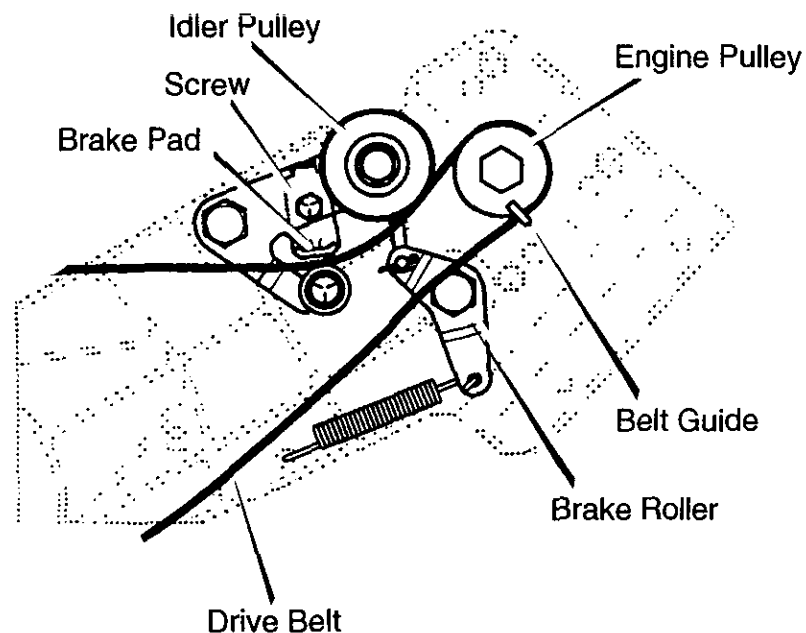

Figure 14

SERVICE AND ADJUSTMENT

TO ADJUST THE CARBURETOR

The carburetor is not adjustable. Engine performance should not be affected at altitudes up to 7,000 feet. For operation at higher elevations, contact your nearest Sears Store.

IMPORTANT: Never tamper with the engine governor, which is factory set for

proper engine speed. Over-speeding the engine above the factory high speed setting can be dangerous. If the engine-governed high speed needs an adjustment, contact an authorized Sears Service Center. They have the proper equipment and experience to make any necessary adjustments.

TO ADJUST OR REPLACE THE SPARK PLUG

Check the **spark plug** every twenty-five (25) hours. Replace the **spark plug** if the electrodes are pitted or burned or if the porcelain is cracked.

The spark plug is housed in the engine compartment under the top cover and cannot be seen under normal conditions.

1. Open the spark plug **access door** on the control panel (Figure 15).
2. The spark plug and wire are now visible.
3. Remove the spark plug wire.
4. Clean the area around the spark plug base to prevent dirt from entering the engine when the spark plug is removed.
5. Remove the spark plug.
6. Check the spark plug. If the spark plug is cracked, fouled or dirty, it must be replaced.
7. Set the gap between the electrodes of the new spark plug at .030 inch (Figure 16).

8. Install the spark plug in the cylinder head and firmly tighten. Recommended torque is 18 to 20 foot pounds.

Access Door

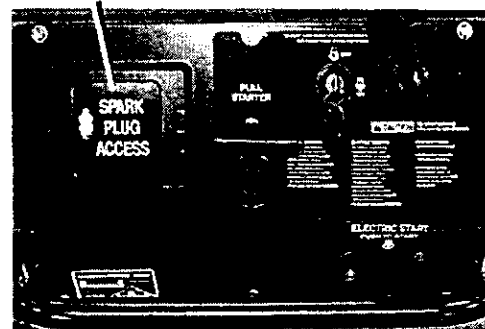

Figure 15

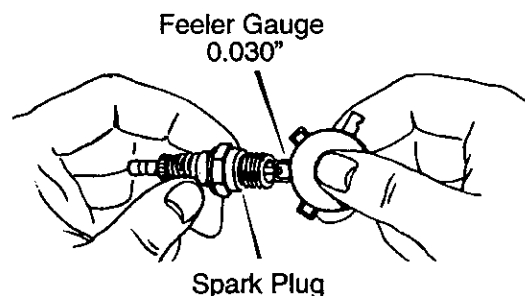

Figure 16

STORAGE



WARNING: Never store your snow thrower indoors or in an enclosed, poorly ventilated area. If gasoline remains in the tank, fumes may reach an open flame, spark or pilot light from a furnace, water heater, clothes dryer, cigarette, etc.

NOTE: To prevent engine damage (if snow thrower is not used for more than 30 days) follow the steps below.

SNOW THROWER

1. Thoroughly clean the snow thrower.
2. Lubricate all lubrication points. See the **Maintenance** section.
3. Be sure that all nuts, bolts and screws are securely fastened. Inspect all visible moving parts for damage, breakage and wear. Replace if necessary.
4. Touch up all rusted or chipped paint surfaces; sand lightly before painting.
5. Cover the bare metal parts of the blower housing auger and the impeller with rust preventative, such as a spray lubricant.

NOTE: A yearly checkup or tune-up by a Sears service center is a good way of ensuring that your snow thrower will provide maximum performance for the next season.

ENGINE



WARNING: Drain the gasoline outdoors, away from fire or flame.

Gasoline must be removed or treated to prevent gum deposits from forming in the fuel tank, filter, hose, and carburetor during storage. Also, during storage alcohol blended gasoline that uses ethanol or methanol (sometimes called gasohol) attracts water. It acts on the gasoline to form acids which damage the engine.

F-001128M

1. To remove gasoline, run the engine until the fuel tank is empty and the engine stops.
2. If you do not remove the gasoline, use fuel stabilizer supplied with unit or purchase Craftsman Fuel Stabilizer No. 3550. Add fuel stabilizer to any gasoline left in the tank to minimize gum deposits and acids. If the fuel tank is almost empty, mix stabilizer with fresh gasoline in a separate container and add some to the fuel tank.
3. Always follow the instruction on the stabilizer container. After the stabilizer is added to the fuel tank, run the engine at least ten minutes to allow the mixture to reach the carburetor.
4. Change the engine oil.
5. Lubricate the piston/cylinder area. First, remove the spark plug and squirt a few drops of clean engine oil into the spark plug hole. Next, cover the spark plug hole with a rag to absorb oil spray. Then, pull two or three times on the recoil starter rope to rotate the engine. Finally, install the spark plug and attach the spark plug wire.

OTHER

1. If possible, store your snow thrower indoors and cover it to give protection from dust and dirt.
2. If the machine must be stored outdoors, block up the snow thrower to be sure the entire machine is off the ground.
3. Cover the snow thrower with a suitable protective cover that does not retain moisture. Do not use plastic.

IMPORTANT: Never cover snow thrower while engine and exhaust areas are still warm.

TROUBLE SHOOTING

TROUBLE	CAUSE	CORRECTION
Difficult starting	Defective spark plug.	Replace spark plug.
	Water or dirt in fuel system.	Use carburetor bowl drain to flush and refill with fresh fuel mixture.
Engine runs erratic	Blocked fuel line, empty gas tank, or stale fuel mixture.	Clean fuel line; check fuel supply; add fresh fuel mixture.
Engine stalls	Unit running on CHOKE.	Set choke lever to run or off position.
Engine runs erratic; Loss of power	Water or dirt in fuel system.	Use carburetor bowl drain to flush and refill with fresh fuel mixture.
Excessive vibration	Damaged auger assembly	Repair or replace the auger assembly.
	Loose parts. Damaged impeller.	Immediately stop engine. Remove ignition key. Tighten all fasteners and make all necessary repairs. If vibration continues, take the unit to a Sears authorized service center.
Unit fails to propel itself	Drive belt loose or damaged.	Replace drive belt.
	Incorrect adjustment of auger drive cable	Adjust auger drive cable.
Unit fails to discharge snow	Auger drive belt loose or damaged.	Adjust auger drive belt; replace if damaged.
	Auger control cable not adjusted correctly.	Adjust auger control cable.
	Discharge chute clogged.	Stop engine immediately and disconnect spark plug wire. Clean discharge chute and inside of auger housing.
	Foreign object lodged in auger	Stop engine immediately and disconnect spark plug wire. Remove object from auger.

CRAFTSMAN 21" 5HP SNOW THROWER 536.885212

ELECTRIC START ASSEMBLY

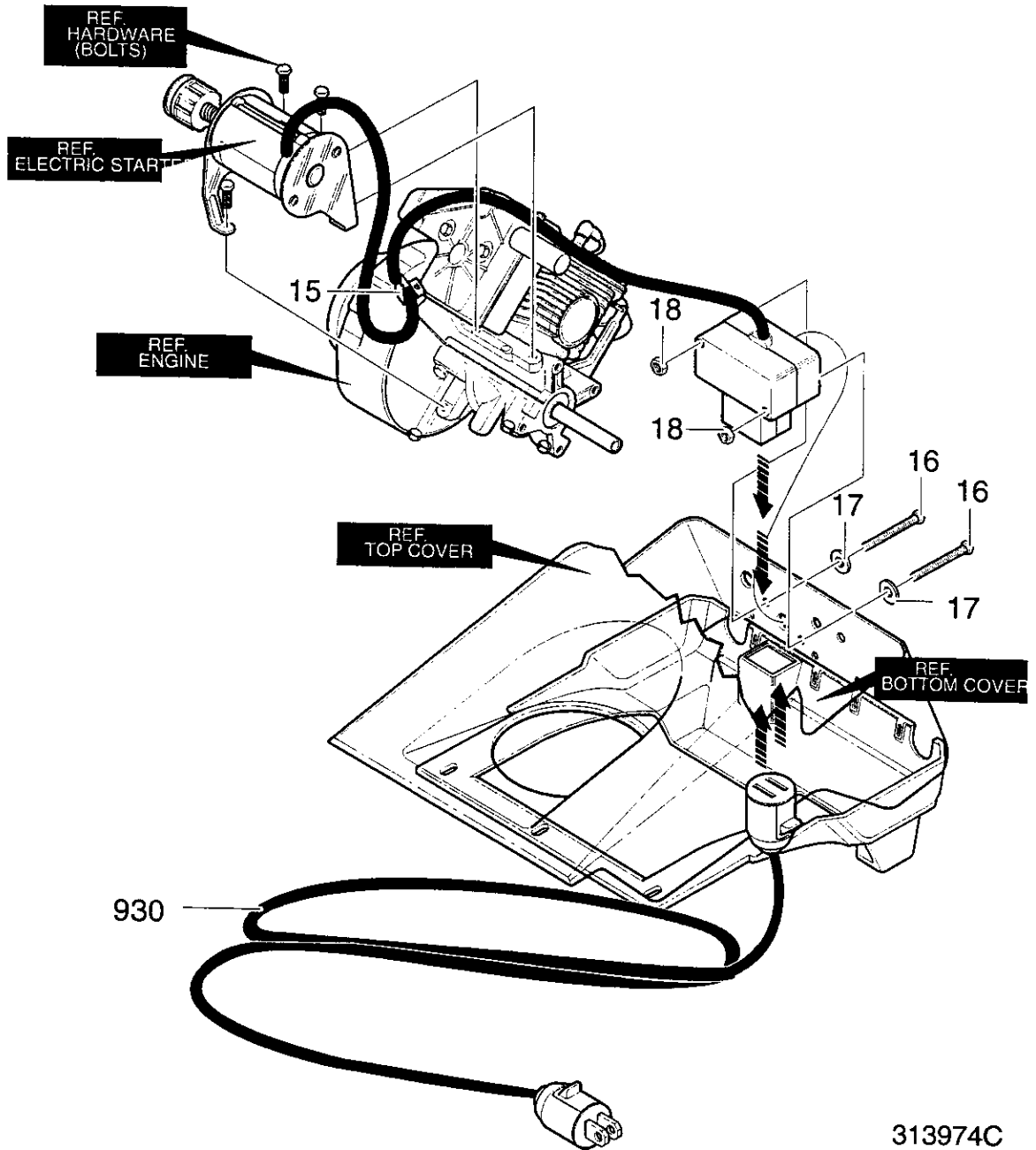

313974C

Key No.	Description	Part No.
15	RETAINER	57569
16	SCREW	311633
17	WASHER, FLAT	414106
18	NUT, KEPS	271163
930	CORD, EXTENSION	56023

F-001128M

CRAFTSMAN 21" 5HP SNOW THROWER 536.885212

FRAME ASSEMBLY

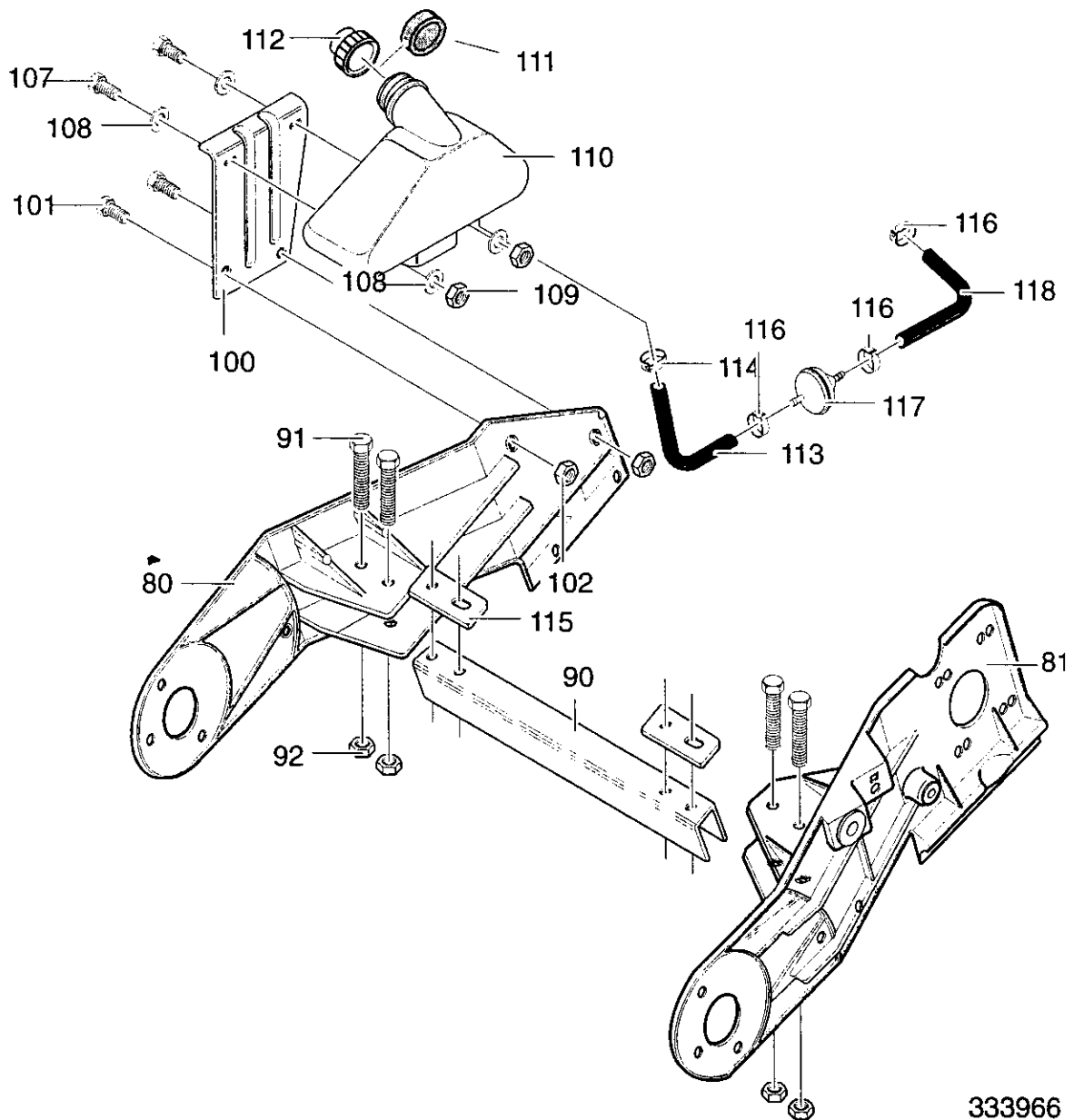

333966

KEY NO.	DESCRIPTION	PART NO.	KEY NO.	DESCRIPTION	PART NO.
80	FRAME, RIGHT SIDE	333769-853	109	NUT, 1/4-20	73826
81	FRAME, LEFT SIDE	333767	110	TANK, FUEL 1.5QT	333739
90	CHANNEL, FRAME	333987	111	RING, FUEL TANK	762224
91	SCREW, 1/4-20X2.00	180044	112	CAP, FUEL	340300
92	NUT, 1/4-20	782585	113	TUBING	323363
100	BRKT, FUEL TANK	333749-853	114	CLAMP, HOSE	47345
101	SCREW, 1/4-20X .75	180020	115	PLATE, SUPPORT	335351
102	NUT, 1/4-20	782585	116	CLAMP, HOSE	323387
107	SCREW, 1/4-20X .75	302628	117	FILTER, IN-LINE	56679
108	WASHER, FLAT	71067	118	TUBING	335906

F-001128M

CRAFTSMAN 21" 5HP SNOW THROWER 536.885212

AUGER ASSEMBLY

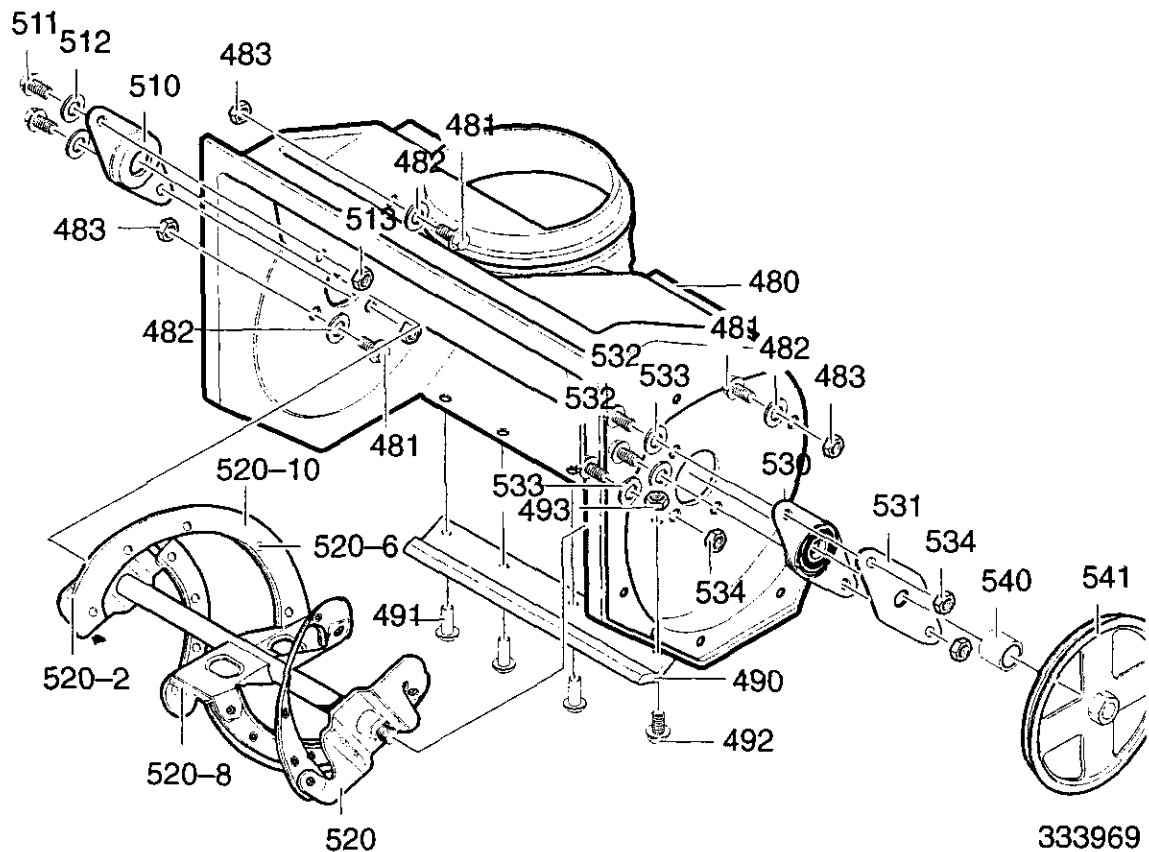

KEY NO.	DESCRIPTION	PART NO.	KEY NO.	DESCRIPTION	PART NO.
480	HOUSING, AUGER	340091	520	AUGER, ASSY	327072
481	SCREW, 1/4-20X .75	302628	520-2	BLADE, AUGER	302565
482	WASHER, FLAT	71067	520-6	RIVET	49838
483	NUT, 1/4-20	73826	520-8	BLADE, CENTER	335992
490	BLADE, SCRAPER	55323	520-10	AUGER BLD ASSY	307049-853
491	RIVET	577707	530	BEARING & PLATE	583459
492	SCREW, 1/4-20X .75	302628	531	PLATE, BEARING	334287
493	NUT, 1/4-20	302635	532	SCREW	579052
510	BRNG, FL 670IDX1.25	577023	533	WASHER, FLAT	71067
511	SCREW, 1/4-20X1.00	710263	534	NUT, 1/4-20	73826
512	WASHER, FLAT	71067	540	SPACER, SLEEVE	578101
513	NUT, 1/4-20	302635	541	PULLEY	333446

CRAFTSMAN 21" 5HP SNOW THROWER 536.885212

HANDLE ASSEMBLY

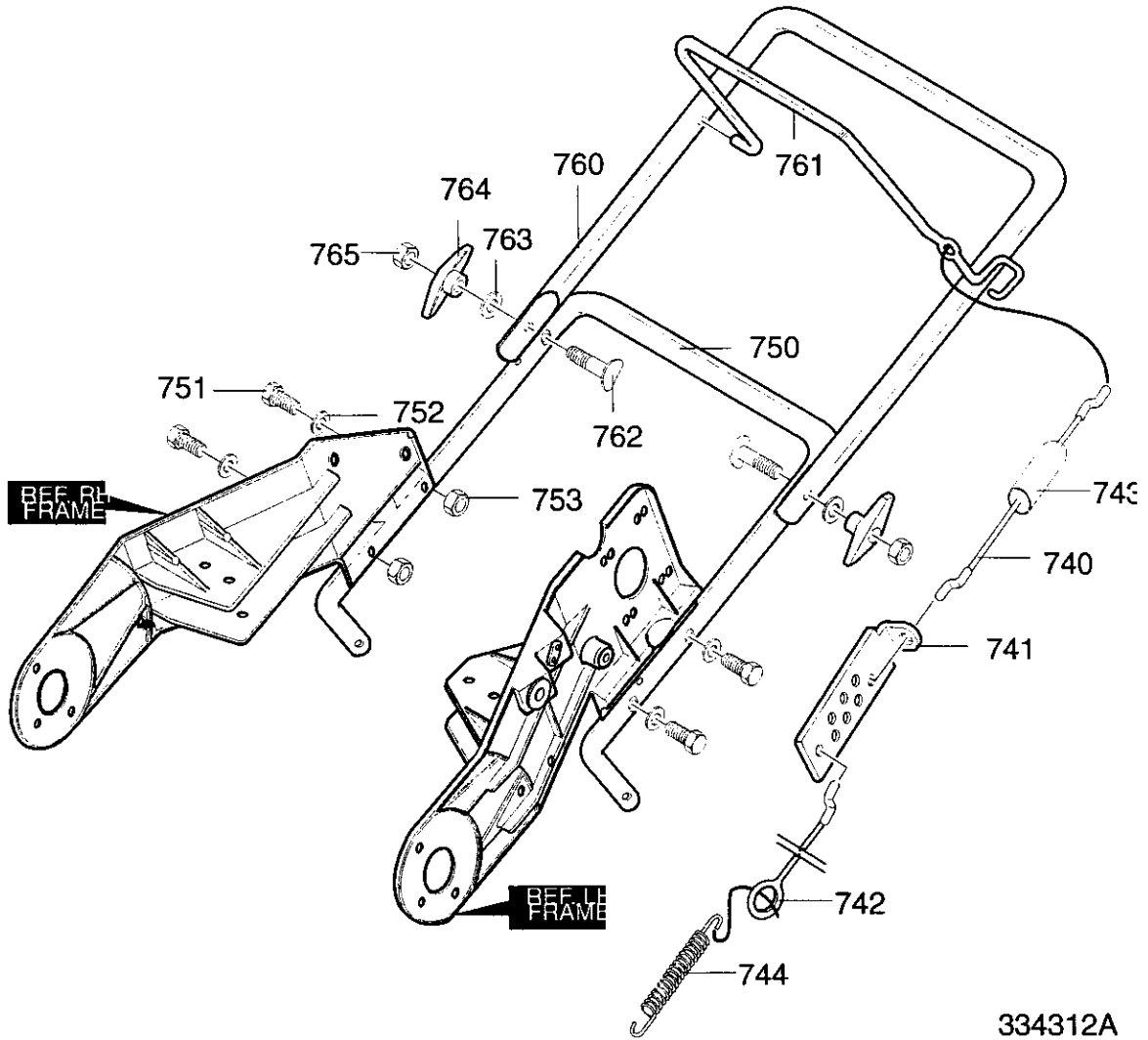

334312A

Key No.	Description	Part No.
740	CABLE, UPPER CONTROL	313449
741	LF BRKT, CABLE ADJ	313441
742	CABLE, LOWER CONTROL	313448
743	BOOT, CLUTCH SPRING	308146
744	SPRING, EXTENSION	313471
750	HANDLE, LOWER	333909-853
751	SCREW, 1/4-20X1.25	313674
752	WASHER, FLAT.	71067
753	NUT, 1/4-20	782585
760	HANDLE, UPPER	333919-853
761	BAIL, CONTROL	333954-853
762	BOLT, 5/16-18X2.00	337584
763	WASHER, FORM	311936
764	KNOB, T 3.00 WD PLAS BLA	57171
765	NUT, 5/16-18 REGHEX	71037



CRAFTSMAN 21" 5HP SNOW THROWER 536.885212

CHUTE ROD ASSEMBLY

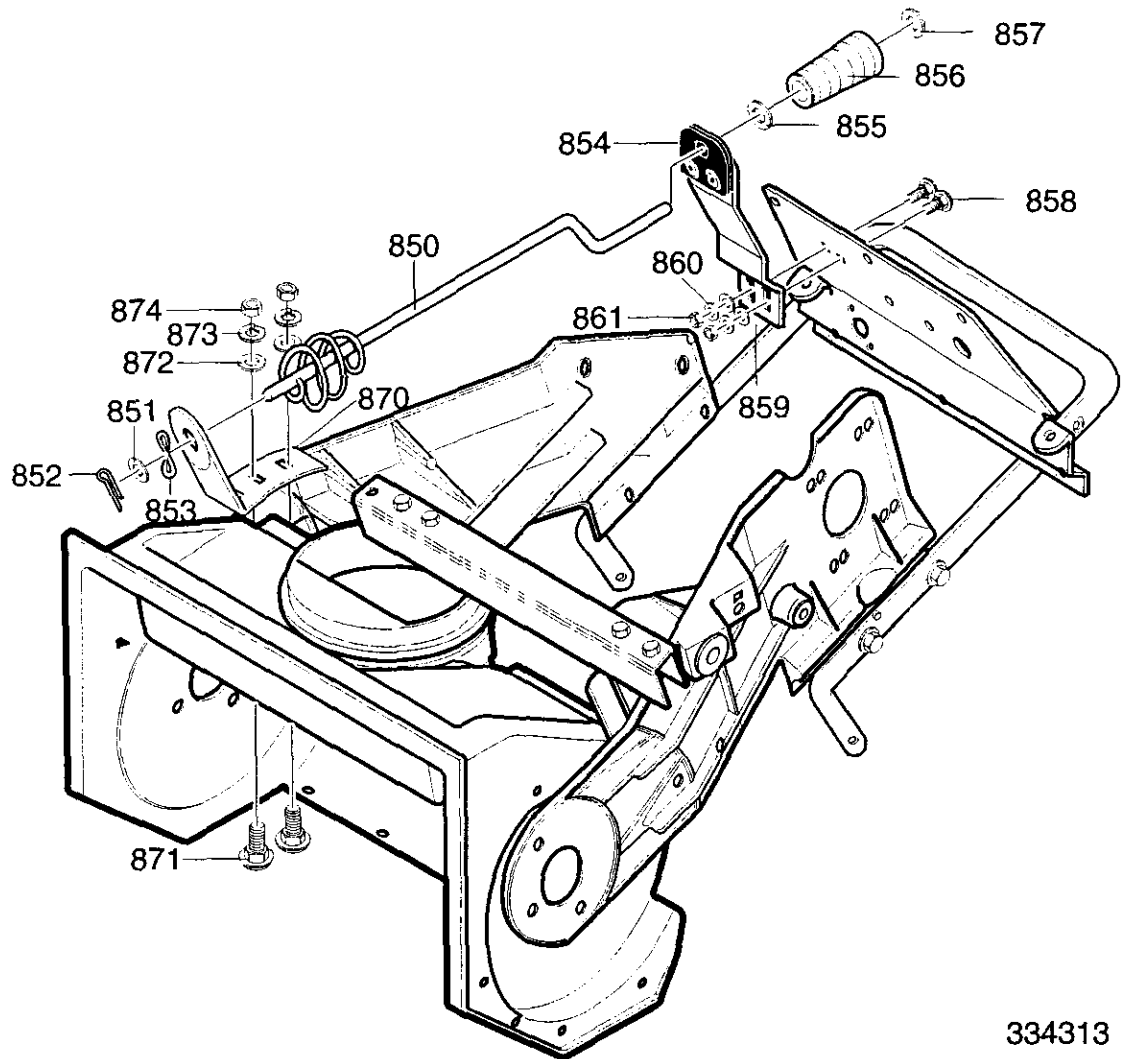

334313

Key No.	Description	Part No.
850	LF ROD, CHUTE	337941
851	WASHER, FLAT	71072
852	PIN, COTTER	71082
853	WASHER, CURVED SPRING	313431
854	SF ASSY, CHUTE CRANK BRKT	335264
855	WASHER, FLAT	71072
856	KNOB, SLEEVE	57082
857	NUT, PUSH, FITS 3/8 DIA	331532
858	BOLT, CARRIAGE	3809
859	WASHER, FLAT	120393
860	WASHER	71060
861	NUT, 1/4-20	71034
870	MP BRACKET, CHUTE ROTATE	333946-853
871	BOLT	340720
872	WASHER, FLAT	71071
873	WASHER	71060
874	NUT, 5/16-18	71037

CRAFTSMAN 21" 5HP SNOW THROWER 536.885212

DISCHARGE CHUTE ASSEMBLY

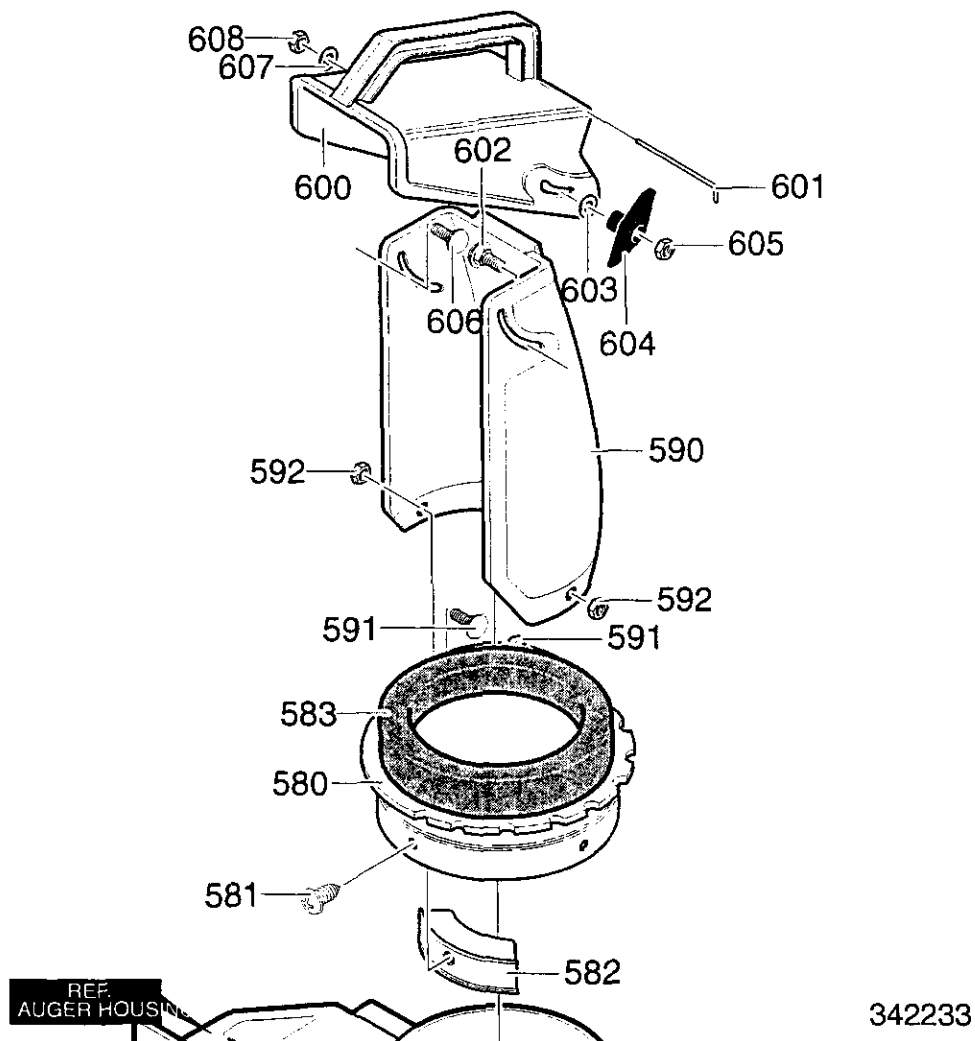

342233

Key No.	Description	Part No.
580	RING, CHUTE	333859
581	SCREW	711752
582	GUIDE, CHUTE	577021
583	DONUT, FOAM	762173
590	CHUTE, LOWER	305862
591	SCREW, 1/4-20X .50	313686
592	NUT, CNTRLK 1/4-20	302635
600	CHUTE, UPPER WITH HANDLE	305861
601	WIRE	310562
602	BOLT, 5/16-18X1.25	302843
603	WASHER, FLAT	71071
604	T-KNOB	57171
605	NUT, 5/16-18	71037
606	SCREW, 5/16-18X	578088
607	WASHER, FLAT	71071
608	NUT, 5/16-18	71391

CRAFTSMAN 21" 5HP SNOW THROWER 536.885212

TOP COVER ASSEMBLY

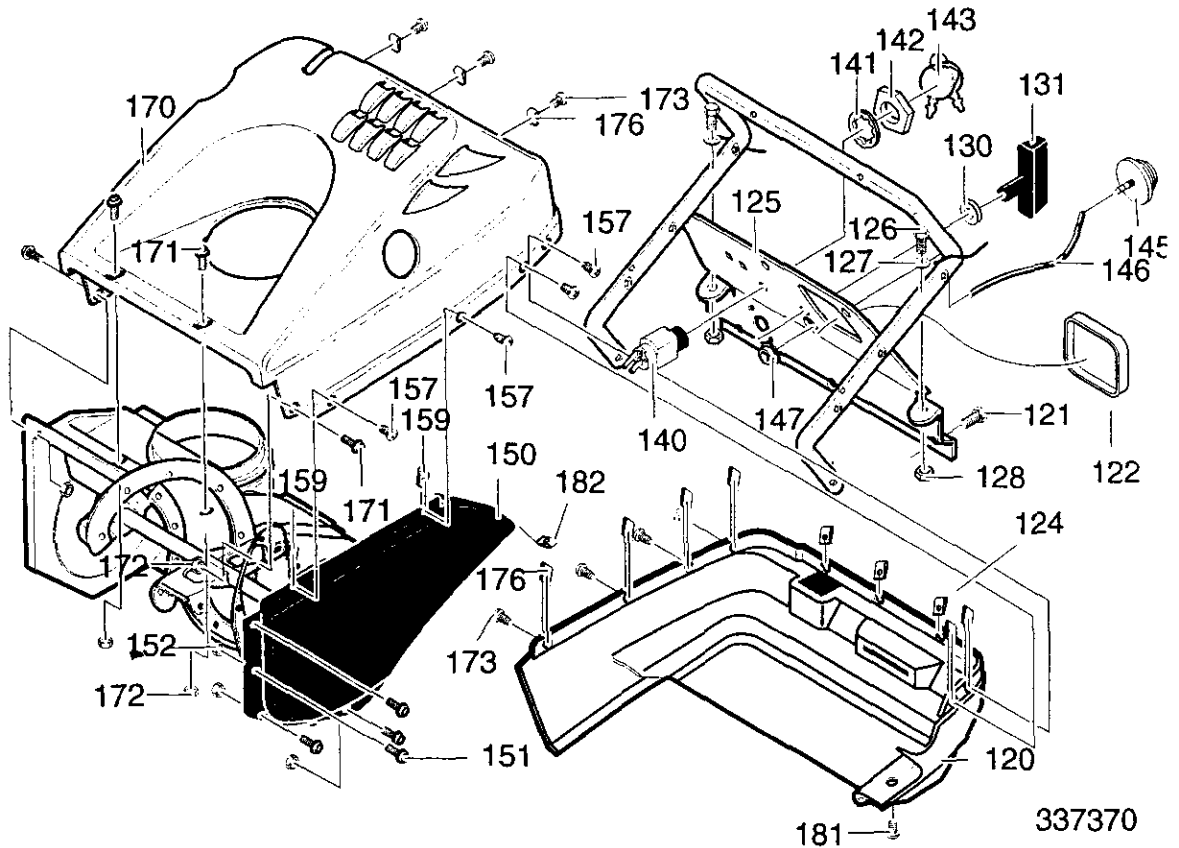

KEY NO.	DESCRIPTION	PART NO.	KEY NO.	DESCRIPTION	PART NO.
120	COVER, BOTTOM	340097	146	HOSE, PRIMER	335507
121	SCREW, 1/4-14X .75	313685	147	NUT, 1/4-20	271172
122	PANEL, ACCESS	761538	150	COVER, BELT	340089
124	NUT, 1/4-10 SPEED	578109	151	SCREW, 10-24X .50	12342
125	PANEL, CONTROL	761539-853	152	NUT, #10-24	312300
126	SCREW, 1/4-20X1.25	313674	157	SCREW, 1/4-14X .75	313685
127	WASHER, FLAT	71067	159	NUT, 1/4-10 SPEED	578109
128	NUT, 1/4-20	782585	170	COVER, TOP	340098
130	GROMMET	57587	171	SCREW, 10-24X .50	12342
131	KNOB, STAND TEE	333643	172	NUT, #10-24	312300
140	SWITCH, IGNITION	56992	173	SCREW, 1/4-14X .75	313685
141	WASHER	313683	176	NUT, 1/4-10 SPEED	578109
142	NUT, 5/8-32	300193	181	SCREW, 1/4-14X .75	313685
143	2 KEYS & RING	49643	182	NUT, 1/4-10 SPEED	578109
145	PRIMER BULB,	54601			

CRAFTSMAN 21" 5HP SNOW THROWER 536.885212

ENGINE DRIVE ASSEMBLY

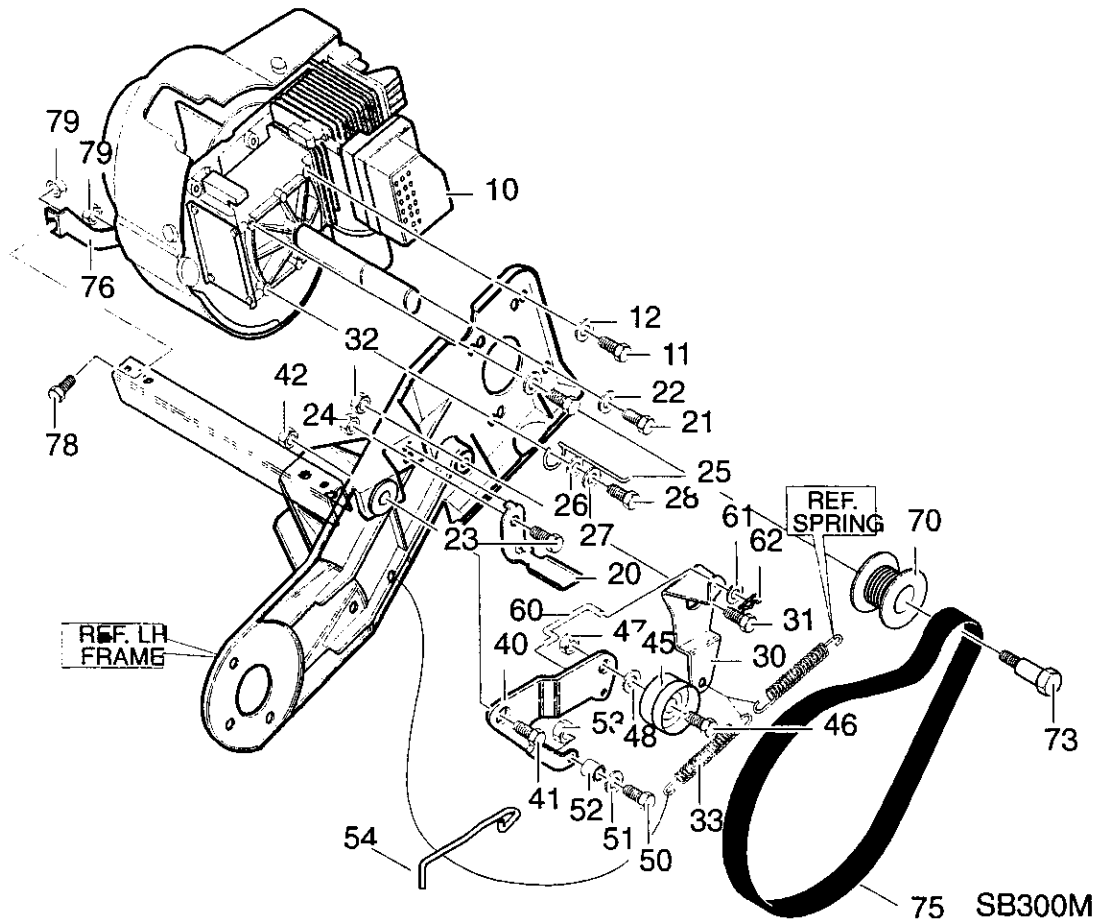

KEY NO.	DESCRIPTION	PART NO.	KEY NO.	DESCRIPTION	PART NO.
10	ENGINE	—	45	PULLEY, IDLER	48924
11	SCREW	180077	46	SCREW	302637
12	WASHER	120638	47	NUT	590
20	LF PAD, BRAKE	333970	48	WASHER, FLAT	301188
21	SCREW	180077	50	SCREW, 1/4-20X2.00	180044
22	WASHER	120638	51	WASHER, FLAT	71067
23	SCREW, 1/4-20X.63	579052	52	ROLLER, PINCH	1501010
24	NUT, 1/4-20	73826	53	NUT, 1/4-20	73826
25	GUIDE, BELT	334079	54	WIRE, BRAKE	1501009
26	WASHER, FLAT	71071	60	ROD, CLUTCH	313436
27	WASHER	120638	61	WASHER, FLAT	414106
28	SCREW	710312	62	PIN, COTTER	121223
30	ARM, IDLER	313444	70	PULLEY	333784
31	BOLT	333594	73	BOLT, SHOULDER	333805
32	NUT, 5/16-18	71391	75	BELT	333721
33	SPRING, EXTENSION	313473	76	BRACKET, SUPPORT	330544
40	LF ARM, IDLER	320077	78	SCREW	48901
41	BOLT	333594	79	NUT, 5/16-18	1498
42	NUT, 5/16-18	71391			
			45	PULLEY, IDLER	48924
			46	SCREW	302637
			47	NUT	590
			48	WASHER, FLAT	301188
			50	SCREW, 1/4-20X2.00	180044
			51	WASHER, FLAT	71067
			52	ROLLER, PINCH	1501010
			53	NUT, 1/4-20	73826
			54	WIRE, BRAKE	1501009
			60	ROD, CLUTCH	313436
			61	WASHER, FLAT	414106
			62	PIN, COTTER	121223
			70	PULLEY	333784
			73	BOLT, SHOULDER	333805
			75	BELT	333721
			76	BRACKET, SUPPORT	330544
			78	SCREW	48901
			79	NUT, 5/16-18	1498



CRAFTSMAN 21" 5HP SNOW THROWER 536.885212

WHEEL ASSEMBLY

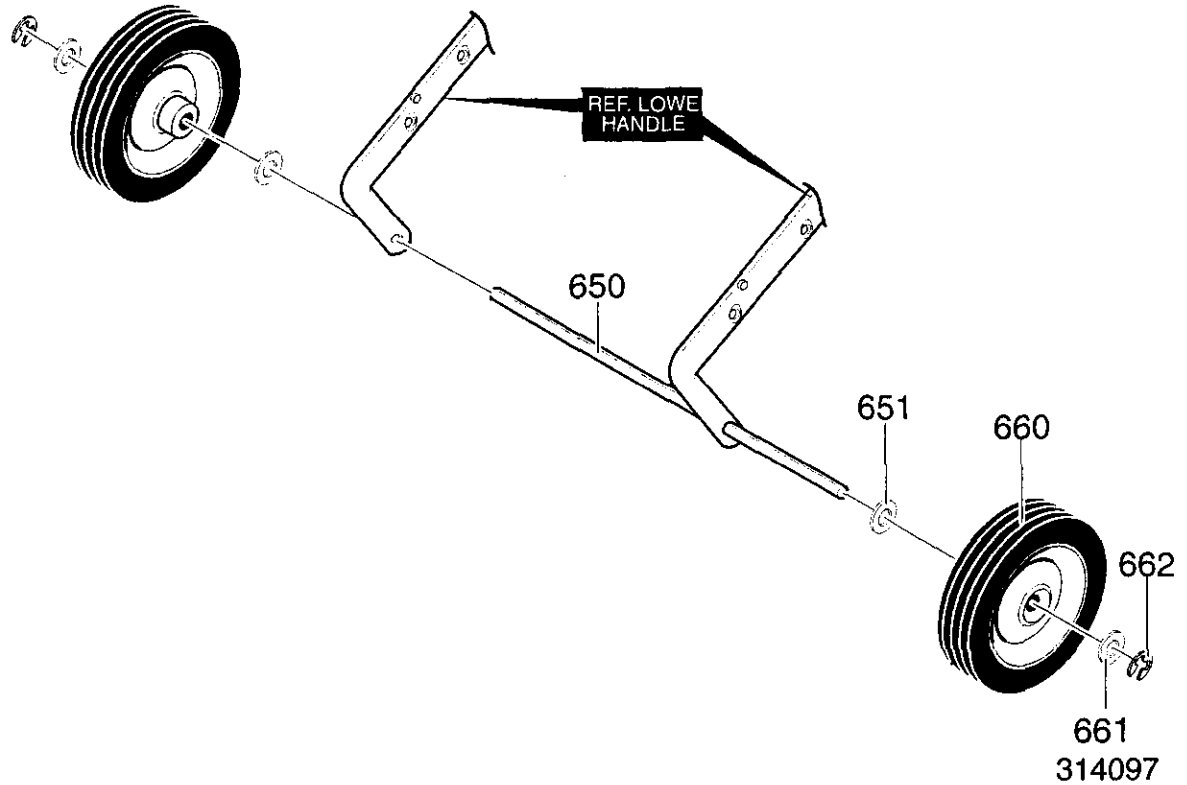

Key No.	Description	Part No.
650	AXLE	313678
651	WASHER, FLAT	583409
660	TIRE & RIM	760713
661	WASHER, FLAT	583409
662	RING, RETAINER	577598

CRAFTSMAN 2-CYCLE ENGINE MODEL 143.015071

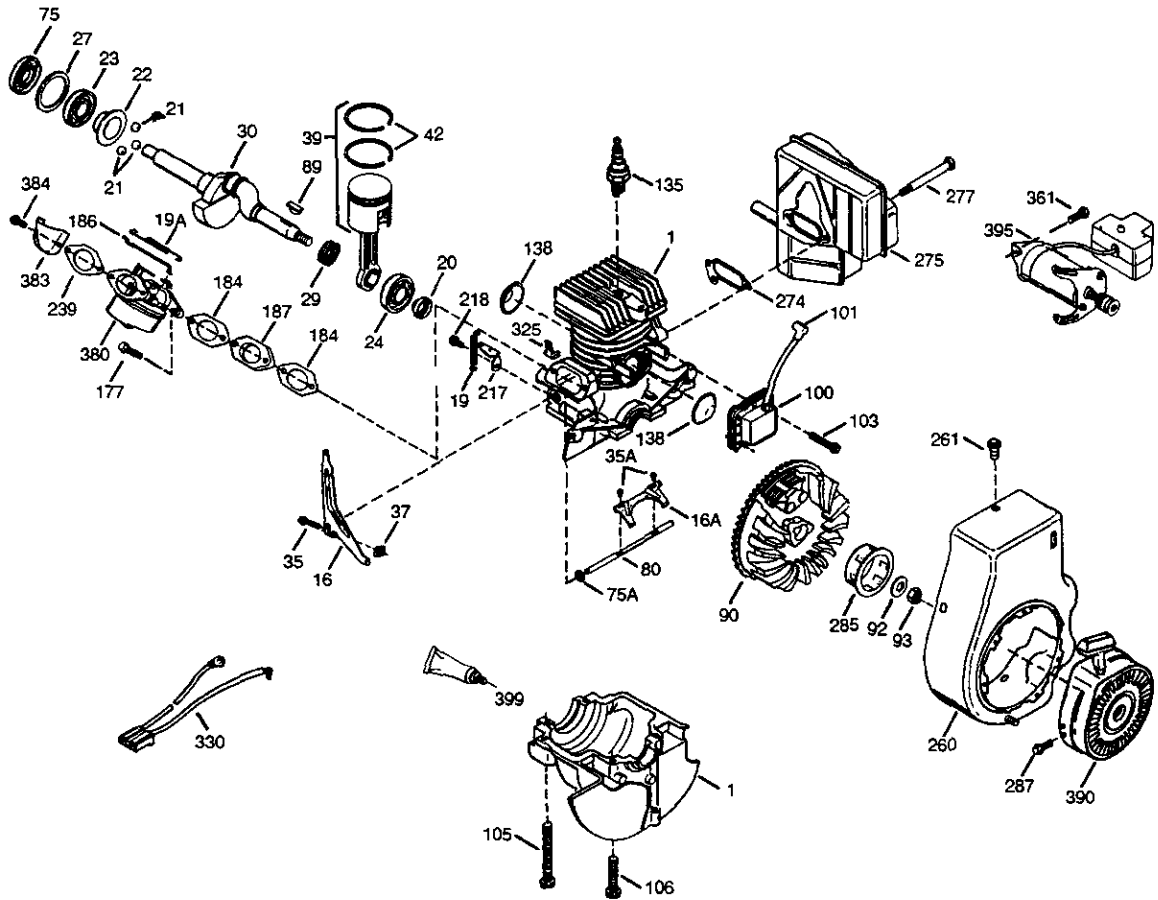
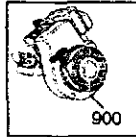

CRAFTSMAN 2-CYCLE ENGINE MODEL 143.015071

KEY NO.	PART NO.	DESCRIPTION	KEY NO.	PART NO.	DESCRIPTION
		RPM High 3700 to 4000	105	650892	Screw, 5/16-18 x 2-3/16"
1	250296A	Cylinder Ass'y. (Incl. 75A, 105, 106, 138)	106	650891	Screw, 5/16-18 x 1-5/8"
16	490317	Governor Lever	135	611049	Resistor Spark Plug (RCJ8Y)
16A	490304	Governor Lever	138	570683	Port Cover
19	570721	Extension Spring	177	650959	Screw, 5/32 Allen
19A	490318	Throttle Link Spring	184	510326A	Carburetor Gasket
20	510340	Oil Seal	186	490319	Governor Link
21	570673	Ball Bearing	187	570438A	Spacer
22	510338	Slide Ring	217	570667A	Control Lever
23	530158	Ball Bearing	218	650847	Screw, 8-32 x 1/2"
24	530161	Ball Bearing	239	35815	Air Cleaner Gasket
27	530159	Bearing Retainer	260	350460	Blower Housing
29	530164	Bearing Strip (31 Needles)	261	650894	Screw, 5/16-18 x 5/8"
30	290627	Crankshaft	274	510343A	Exhaust Gasket
35	29826	Screw, 10-32 x 3/4"	275	390325	Muffler
35A	650506	Screw, 4-40 x 1/4"	277	650893	Screw, 5/16-18 x 3-13/64"
37	29216	Lock Nut, 10-32	285	34449A	Starter Cup
39	310277B	Piston & Rod Ass'y. (Incl. 29 & 42)	287	650926	Screw, 8-32 x 21/64"
42	310278	Ring Set	325	29443	Wire Clip
75	510339	Oil Seal	330	611158	Wire Harness
75A	510337	Oil Seal	361	30063	Screw, T-30, 1/4-20 x 1/2"
80	490305	Governor Shaft	380	640088	Carburetor (Incl. 184)
89	611191	Flywheel Key	383	570695	Carburetor Baffle
90	611192	Flywheel	384	650229	Screw, T-25, 10-32 x 3/8"
92	650815	Belleville Washer	390	590743	Rewind Starter
93	650816	Flywheel Nut	395	590670	Electric Starter Motor
100	34443B	Solid State Ignition	399	510334	Gasket Eliminator (Loctite 515)
101	610118	Spark Plug Cover	900	0	Replacement Engine None
103	651007	Screw, T-15	900	0	Replacement Short Block 710496B

CRAFTSMAN 2-CYCLE ENGINE MODEL 143.015071

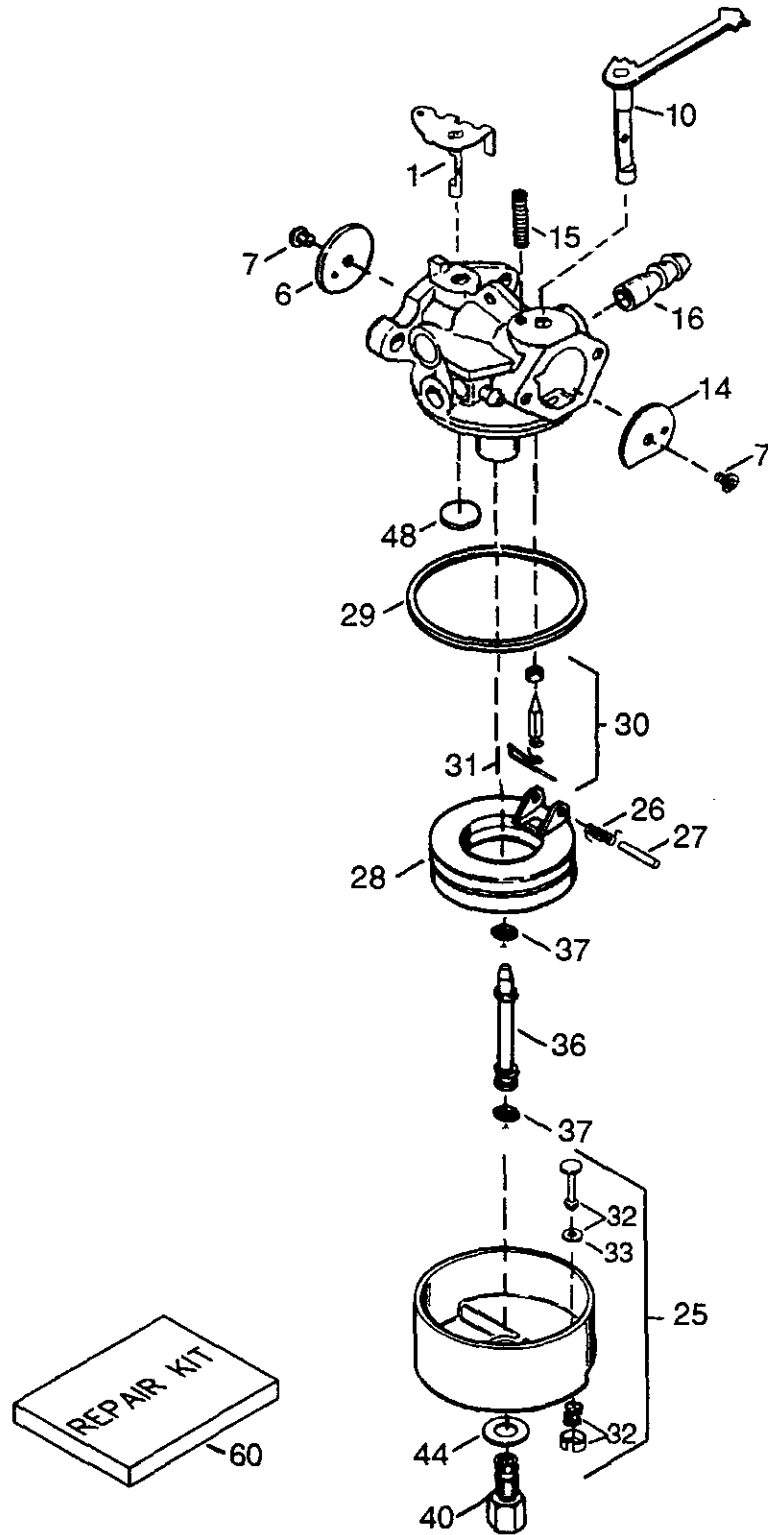

F-001128M

34



CRAFTSMAN 2-CYCLE ENGINE MODEL 143.015071

KEY NO.	PART NO.	DESCRIPTION
0	640088	Carburetor (Incl. 184 of Engine Parts List)
1	632538	Throttle Shaft & Lever Assembly
6	631621	Throttle Shutter
7	650506	Shutter Screw
10	632734	Choke Shaft & Lever Assembly
14	631815	Choke Shutter
15	630735	Choke Positioning Spring
16	632164	Fuel Fitting
25	631951	Float Bowl Assembly (Incl. 32 & 33)
26	632386	Float Dampening Spring
27	631024	Float Shaft
28	632019	Float
29	631028	Float Bowl "O" Ring
30	631021	Inlet Needle, Seat & Clip (Incl. 31)
31	631022	Spring Clip
32	27136A	Bowl Drain Assembly
33	27554	Drain Plunger Gasket
36	640080	Main Nozzle Tube
37	632547	"O" Ring, Main Nozzle Tube
40	640089	High Speed Bowl Nut
44	27110A	Bowl Nut Washer
48	631027	Welch Plug, Atmospheric Vent
60	632760	Repair kit (Incl. Items Marked PK in Notes)

CRAFTSMAN 2-CYCLE ENGINE MODEL 143.015071

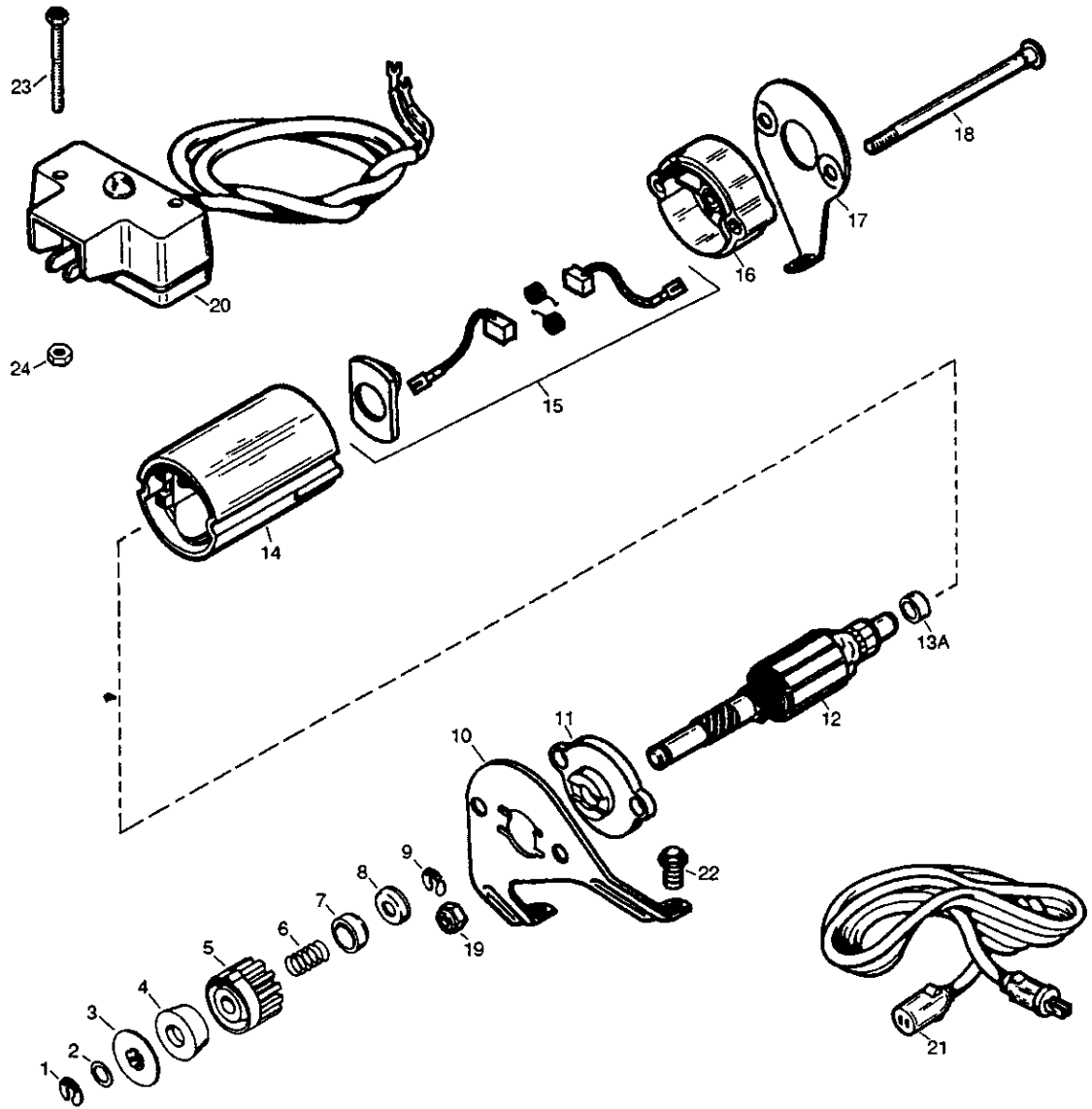

KEY NO.	PART NO.	DESCRIPTION	KEY NO.	PART NO.	DESCRIPTION
0	590670	Electric Starter (110 Volt)	13A	590677	Thrust Spacer
1	34952	Retainer Ring	14	590659	Housing Ass'y.
2	590608	Dust Washer	15	590587	Brush & Spring Card
3	34953	Pinion Driver	16	590660	Commutator End Cap
4	590644	Anti-drift Spring	17	590661	Commutator End Bracket
5	34949A	Gear	18	590662	Case Bolt
6	590654	Anti-drift Spring	19	33450	Lock Nut
7	34950	Spring Retainer	20	590663A	Switch Box & Lead Ass'y.
8	34951	Cup Washer	21	32450B	Extension Cord (10'6")
9	34955	Retainer Ring	22	30063	Screw, Torx T-30
10	590674	Drive End Mount Bracket	23	650819	Screw, 6-32 x 2-1/2"
11	590675	Drive End Cap Ass'y.	24	650742	Nut & Washer Ass'y.
12	590676	Armature			

F-001128M

CRAFTSMAN 2-CYCLE ENGINE MODEL 143.015071

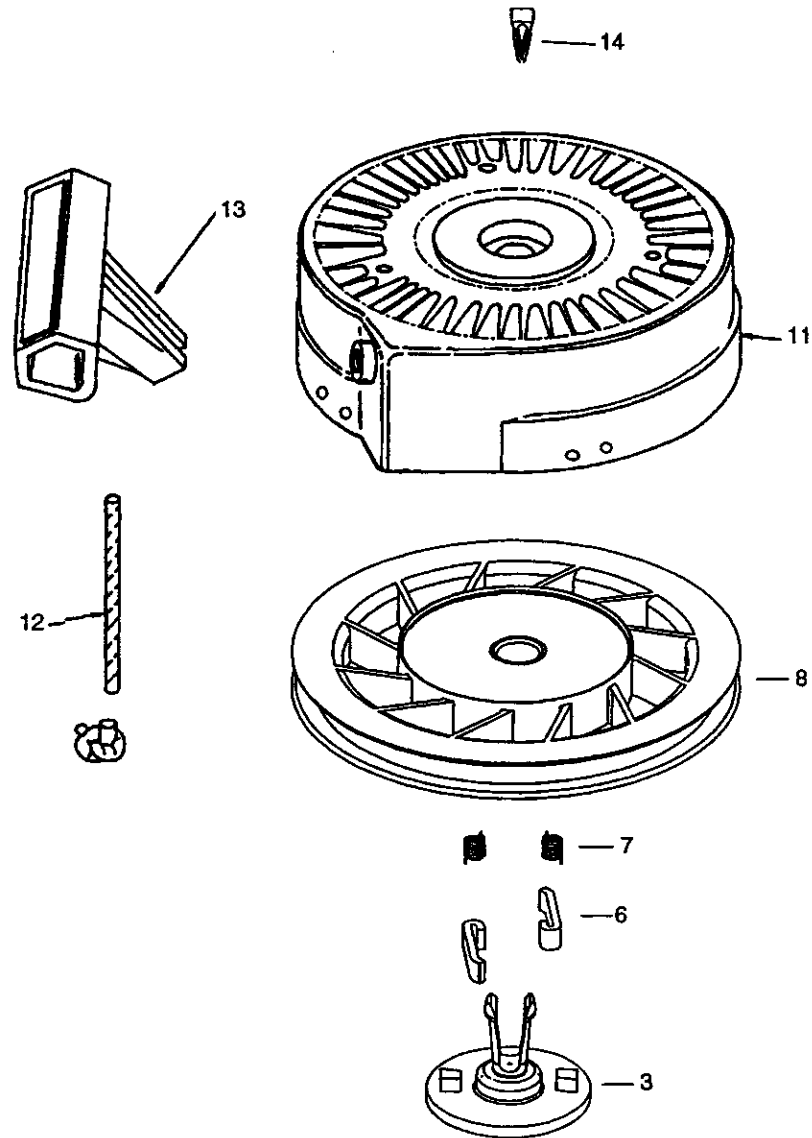

KEY NO.	PART NO.	DESCRIPTION	KEY NO.	PART NO.	DESCRIPTION
0	590743	Rewind Starter	11	590643	Starter Housing Ass'y
3	590740	Retainer	12	590535	Starter Rope
6	590616	Starter Dog	13	590701	Starter Handle
7	590617	Dog Spring	14	590760	Spring Clip
8	590645A	Pulley & Rewind Spring			

For the repair or replacement parts you need delivered directly to your home
Call 7am-7pm, 7days a week

1-800-366-PART

(1-800-366-7278)

Para ordenar piezas con entrega a domicilio - 1-800-659-7084

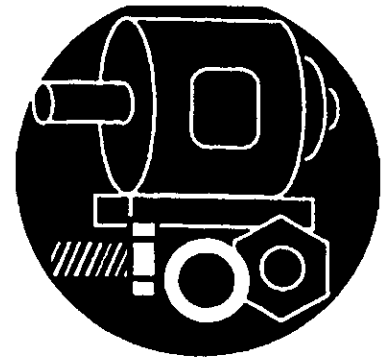

For in-house major brand repair service
Call 24 hours a day, 7days a week

1-800-4-REPAIR

(1-800-473-7247)

Para pedir servicio de reparación a domicilio- 1-800-676-5811



For the location of a Sears Parts and Repair Center in your area

Call 24 hours a day, 7days a week

1-800-488-1222



For information on purchasing a Sears Maintenance agreement or to inquire about an existing Agreement

Call 9am-5pm, Monday-Saturday

1-800-827-6655



When requesting service or ordering parts, always provide the following information:

- Product Type
- Part Number
- Model Number
- Part Description

SEARS

REPAIR SERVICES

America's Repair Specialists

Printed in U.S.A.