

Intelligent Wire-Free Combo Smoke / CO Alarm

10-Year Sealed Battery Powered with Wire-Free Interconnect



Technology that saves lives.

Model P4010DCSCO-W

DC Combo Alarm



10-Year Sealed Lithium Battery
Eliminates late night battery chirp!

Voice Notifications

Bug Screen
Protects alarm from insect ingress

Flashing LED Status Ring allows easy identification of current state of alarm



Green:
Device is Working



Amber:
Error



Red:
Danger Detected

Description

The P4010DCSCO-W is a 10-year, sealed battery smoke and carbon monoxide (CO) alarm that features supervised wire-free interconnect capability and provides enhanced intelligibility for users. The voice warning feature accompanies the 85dB tone during an alarm event, and helps reduce confusion with verbal announcements such as "Replace alarm" at end of alarm life, and "Hush mode activated" when a nuisance alarm is silenced. The three color LED ring helps users quickly determine standby, alarm, or error mode of the alarm.

Kidde P4010 Series Alarms contain 10-year tamper proof batteries that eliminate the need for battery replacement, and ends worry over unauthorized removal. Users are further shielded from late night battery chirps by the unit's Ambient Light Sensing feature, which establishes a day/night cycle and prevents alarm chirping in dark conditions.

Wire-Free Interconnect triggers each connected alarm in the home to sound once smoke is detected, which can provide more time to react. The National Fire Alarm and Signaling Code (NFPA 72) has required smoke alarms in new homes to be interconnected since 1989, which traditionally involves running wiring to each alarm. Older and remodeled homes can now be updated to current standards without having to run any wiring to each alarm through walls and ceilings. Existing networks of interconnected alarms can be expanded with use of a single AC Wire-Free Alarm and additional compatible DC Wire-Free alarms.

Additional benefits and features are available when used in conjunction with the **Kidde Remotelync Bridge**, which connects P4010 Wire-Free alarms via your home's Wi-Fi to your smart device. Additional information such as battery life and sensor health status are available from each assigned room location. Weather alerts, and intruder alerts (when used with the Kidde Remotelync camera), can be sent to each connected alarm, creating an easy to install fire – security – weather – warning system from one network of devices.

Features and Benefits

Supervised Wire-Free Interconnect: Proprietary radio signal joins multiple alarms together, so when one alarm sounds they all sound. User is alerted if an alarm loses connection to the network.

Sealed-in Lithium Battery: No battery replacement required over the 10 year life of the alarm. Eliminates worry about battery removal or unauthorized deactivation of alarm.

Voice Notifications: Unit verbally announces "Fire!" and other alerts such as "Replace Alarm," which helps the user better understand current status of the unit.

Easy to Install: Simply turn the switch on the back of unit or mount to bracket to activate the alarm. Multiple units can be interconnected with push of one button.

Intelligent Sensor Technology: Reduces nuisance alarms and offers fast response to real fires.

Ambient Light Sensing: Establishes Day/Night cycle and prevents chirping during the night until the next Day cycle begins.

Alarm Locate Feature: Quickly find initiating alarm by silencing other alarms in the network.

Test/Hush® Button: Tests alarm circuitry and activates Hush® feature to temporarily silence nuisance alarms for up to 10 minutes. End of Unit Life and Network Error chirps can also be silenced.

End of Unit Life Warning: Alerts user the alarm is in need of replacement.

Compatible with Remotelync Bridge: Connect to the Kidde app for additional features and benefits.

10-Year Limited Warranty



Architectural and Engineering Specifications

The smoke/CO alarm model shall be P4010DCSCO-W or approved equal and is powered by non-replaceable lithium metal batteries with 10-year life. The lithium batteries shall be sealed in the unit to prevent removal and/or tampering. The unit shall incorporate a photoelectric smoke sensor and an electrochemical CO sensor.

The alarm can be installed on the surface of any wall or ceiling following the UL/Manufacturer's approved placement guidelines. The alarm shall incorporate an activation switch that can be engaged with the included tool or screwdriver to power on the alarm at startup, and deactivate the alarm at end of alarm life.

The P4010DCSCO-W shall include a test button that will simulate fire and carbon monoxide conditions and cause the unit to go into alarm. This sequence tests the unit's electronics to ensure proper operation.

The unit shall have audible methods for warning of smoke or fire danger: a piezoelectric horn, rated at 85 decibels at 10 feet, and a voice warning. In a smoke incident, the horn will sound in the repetitive manner – three long beeps, a 1.5 second pause, three long beeps, repeating. In between, the unit will announce a voice warning, "Fire!" For a CO incident, the horn will sound in the repetitive manner - 4 quick beeps, voice message "Warning! Carbon Monoxide", 4 quick beeps. The red LED ring will flash in conjunction with the alarm sound.

The unit shall incorporate wireless alarm interconnect capability, whereas when one interconnected unit sounds an alarm, all other compatible wireless units in the wireless alarm network will alarm. The maximum distance between wireless interconnect models is greater than 300 feet in open air. The alarm interconnect shall be supervised, where an audible and visual indication is given if the alarm loses connection to other units in the network.

A maximum of 24 Kidde Safety devices may be interconnected in a multiple station arrangement. The interconnect system should not exceed the NFPA interconnect limit of 12 smoke alarms and/or 18 alarms total (smoke, CO, Smoke/ CO Combination, heat, etc.). With 18 alarms interconnected, it is still possible to interconnect up to a total of 6 remote signaling devices and / or relay modules.

The unit shall at a minimum meet the requirements of UL217, UL 2034, NFPA 72, The State of California Fire Marshall, NFPA101 (One and two family dwellings), Federal Housing Authority (FHA), Housing and Urban Development (HUD). The alarm shall be UL Listed and shall include a 10-year manufacturer's limited warranty.

Technical Specifications

Model:	P4010DCSCO-W
Power Source:	Sealed Lithium Batteries
Sensor:	Smoke: Photoelectric CO: Electrochemical
Audio Alarm:	85dB at 10ft
Temperature Range:	40°F (4.4°C) to 100°F (37.8°C)
Humidity Range:	10 to 95% non-condensing relative humidity (RH)
Size:	5.59" in diameter x 1.91" depth
Weight:	0.6 lb
Interconnects:	Up to 24 Kidde devices
Warranty:	10 year limited

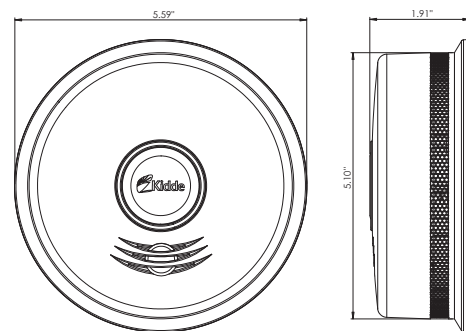

Compatible Intelligent Wire-Free 10-Year Models

10-Year Sealed Battery Operated Alarms

P4010DCS-W:	Smoke Alarm with Wire-Free Interconnect
P4010LDCS-W:	Smoke Alarm with Wire-Free Interconnect and Emergency Safety Light
P4010DCSCO-W:	Combination Smoke and CO Alarm with Wire-Free Interconnect

HARDWIRED Alarms with 10-Year Sealed Battery Backup

P4010ACS-W:	Smoke Alarm with Wire-Free Interconnect
P4010LACS-W:	Smoke Alarm with Wire-Free Interconnect and Emergency Safety Light
P4010ACSCO-W:	Combination Smoke and CO Alarm with Wire-Free Interconnect

Leading authorities recommend that both ionization and photoelectric smoke alarms be installed to help ensure maximum detection of the various types of fires that can occur within the home. Ionization sensing alarms may detect invisible fire particles (associated with fast flaming fires) sooner than photoelectric alarms. Photoelectric sensing alarms may detect visible fire particles (associated with slow smoldering fires) sooner than ionization alarms.

Ordering Information

Ordering No:	UPC	1 of 5	Pack Config.	Pack Qty	Dimensions (w" x d" x h")	Weight	Cartons/ Pallet
21027311	0-47871-27311-9	100-47871-27311-6	Single	2	8.25 x 6.25 x 9.5	2.5	136
21027680 (Red Cross)	0-47871-27311-9	100-47871-27311-6	Single	2	8.25 x 6.25 x 9.5	2.5	136

Distributed by:



1016 Corporate Park Drive
Mebane, NC 27302
1-800-880-6788
www.Kidde.com