



# BEVERAGE-AIR®

## **INSTALLATION AND OPERATING INSTRUCTIONS** **for all Hydrocarbon** **NC Freezer Models**



809-165A REV. A. 02/10/2026

3779 CHAMPION BLVD, WINSTON-SALEM, NC 27105

Phone: (888) 845-9800 | Fax: (800) 253-5168 | Web: [beverage-air.com](http://beverage-air.com)

**SEE BACK COVER FOR  
WARRANTY REGISTRATION**



WELCOME

Thank you for purchasing a Beverage-Air cabinet. This series has passed our strict quality control inspection and meets the high standards set by Beverage-Air! You have made a quality investment that with proper maintenance will give you many years of reliable service!

Please read the following installation and maintenance instructions before installing or using your unit.

Important Information

- PLEASE READ THESE INSTRUCTIONS CAREFULLY BEFORE INSTALLING OR USING, IF RECOMMENDED PROCEDURES ARE NOT FOLLOWED, WARRANTY CLAIMS MAY BE DENIED.
Your warranty registration information is located within this manual. Please complete the card and submit it to Beverage-Air within TEN days of installation. Failure to properly register equipment may limit or void the warranty.
Beverage-Air reserves the right to change specifications and product design without notice. Such revisions do not entitle the buyer to corresponding changes, improvements, additions, or replacements for previously purchased equipment.

Safety ..... 3
Important Information ..... 5
Product Information ..... 6
Clearance and Placement .....7
Unpacking and Set Up ..... 8
Electrical ..... 9
Environmental Conditions .....10
Cleaning and Maintenance ..... 11
Methods For Cleaning Exterior Finish .....12
For The Service Tech - R290 .....13
Power/Freeze Failure .....14
Limited Warranty .....15
Limited Warranty (continued) .....16



## SAFETY

This appliance has been designed with your safety in mind. It has many features to keep you from being harmed. However, safe operation and maintenance are your responsibilities. **USE THIS APPLIANCE FOR ITS INTENDED PURPOSE AS DESCRIBED IN THIS MANUAL.**



### Use: When using this unit, please:

- **Move it carefully.** If on casters be sure the casters do NOT run over the power cord.
- **Lock** the casters when in use.
- **Seek help.** This machine is heavy! Be sure to move with enough help to avoid tipping or dropping the cabinet.
- **Prevent children from playing in or on the cabinet.** Persons unable to use this product must be prevented access.
- **Follow all instructions.** There are many safety labels and directions on the unit. Heed them.
- **Watch your fingers.** There may be pinch points near the door hinges.



### Maintenance

#### Do NOT:

- Clean a frozen evaporator with a sharp object
- Clean a dirty condenser with a sharp object.
- Store or use gasoline, kerosene or any other flammable material near the cabinet.

#### Do ALWAYS

- Use a Beverage-Air recommended technician certified to repair R290 equipment.
- Use **ONLY** Beverage-Air factory service parts. Use of non OEM parts can be dangerous because of the design changes needed to safely use R290.

### Important Information to Add

Record the model number, serial number and the date of installation here for future reference. The model and serial numbers are on the unit's serial number dataplate, which is located on the left inside wall.

<b>Model Number</b>	
<b>Serial Number</b>	
<b>Date of Installation</b>	
<b>Purchased From</b>	



Observe the **Caution** and **Warning** notices. They are indicators of important safety information. Keep this manual for future reference.

Using any electrical or electronic equipment entails the compliance with some fundamental rules.

**THE MANUFACTURER DOES NOT ASSUME ANY RESPONSIBILITY ARISING FROM DAMAGES CAUSED BY IMPROPER, INCORRECT, OR ERRONEOUS USE.**

1. Do not touch the unit with wet hands or feet.
2. Do not install the equipment outdoors.
3. Do not remove or ignore safety devices.
4. Do not leave objects on top of the unit.
5. Do not climb on top of the unit.
6. Do not allow children to climb, stand, or hang on the shelves in the freezer. This could damage the freezer and seriously injure themselves.
7. Never use direct or indirect water jets on the unit.
8. Do not allow the electronic control to be adjusted by customers or unqualified personnel. For any adjustment, you must contact your distributor.
9. Verify that the hot air stream from the condenser toward the back of the unit is not directed to other refrigeration units, as this would compromise their operation.
10. Under no circumstance, should you block the front grille of the unit.
11. Use care when moving or handling the unit. It is equipped with flammable refrigerant and damage to refrigerant tubing will increase the risk of a leak.
12. When service is required, seek factory authorized technicians trained to safely maintain and service systems that utilize flammable refrigerants, such as R-290. RSES offers such training and certification.
13. Only use factory authorized replacement parts to minimize the risk of possible ignition.

**It is important to instruct the user on the operation of the equipment according to this instruction manual, and make sure that the manual is within reach of any operator that might use the unit.**

## IMPORTANT INFORMATION

This unit is intended to be used in a commercial application. That includes bars and restaurants.

If installed in a residence some commercial service companies may not be able to service it on site.

The manufacturer has designed and produced this machine with the finest in materials. The manufacturer assumes no liability for units that have been altered in any way. Alterations or part substitutions will void the warranty.

This appliance must be properly installed and located in accordance with this manual.

### Limitations

The machine is designed for use indoors in a controlled environment. It must be kept dry, not overheated or subjected to excessive cold. May only be connected to a dedicated electrical circuit. Extension cords are not permitted.

### Agency Approvals

These marks appear on the dataplate or serial tag, located in the inside of the left wall. The dataplate also contains the model and serial numbers as well as electrical requirements.



## PRODUCT INFORMATION

Model	Cabinet Dimensions w x d x h (Inches)	Full Load Amps	Power Cord Plug (NEMA)	Refrigerant Type / Charge (g) / Charge (oz)	
NC28HC-1-W	27 7/8 X 26 X 34 3/16	3.0	5-15P	R-290 / 60 / 2.11	
NC34HC-1-W	33 13/16 X 26 X 34 3/16			R-290 / 70 / 2.47	
NC43HC-1-W	42 1/2 X 26 X 34 3/16	3.5		R-290 / 90 / 3.17	
NC51HC-1-W	50 3/8 X 26 X 34 3/16				
NC60HC-1-W	60 3/16 X 26 X 34 3/16	4.0			R-290 / 100 / 3.52
NC68HC-1-W	68 1/8 X 26 X 34 3/16				

- Exterior is white powder coated painted steel.
- All models will maintain product temperature between 0 and -10°F.
- All models are 120 volts, 60 Hz AC.
- ALWAYS REFERENCE YOUR EQUIPMENT DATA PLATE AMPS, REFRIGERANT AND REFRIGERANT CHARGE FOR THE MOST UP TO DATE AND ACCURATE VALUES.
- There are no access valves on the refrigeration system.

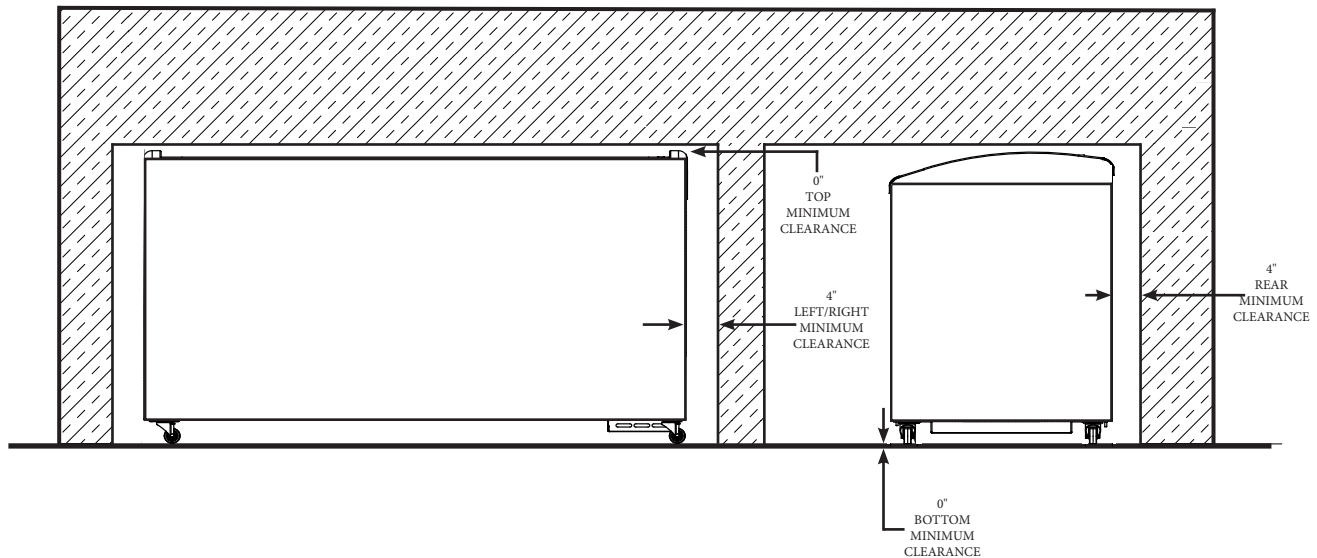
**CLEARANCE AND PLACEMENT****Placement**

Consider the following when selecting a location for your Freezer:

**Clearance:**

- 0.0 in. at the top
- 4.0 in. at the rear
- 4.0 in. at the left side
- 4.0 in. at the right side
- 0.0 in at the bottom

**Floor Load:** the floor on which the Freezer is located must be even and level, free from vibrations, and strong enough to support the combined weights of the unit and maximum product load.

**Ventilation:** Grille area at front must be free and clear of any object or wall.

**Power Outlet:** Dedicated power outlet is located within the length of the unit's power cord.

## UNPACKING AND SET UP

Carefully inspect the shipping carton for damage. This is the only time that shipping damage may be claimed. If damage is suspected, open the carton immediately and, if there is damage, retain the carton and contact the shipper to make a claim. Do NOT contact the manufacturer.

Destroy carton, plastic bags, and any exterior wrapping material immediately after the freezer has been unpacked. Children should never use these items for play. Cartons covered with rugs, bedspreads, plastic sheets or stretch wrap could become airtight chambers and can quickly cause suffocation. The spacers used to secure the shelves during shipping should also be discarded immediately, as they pose a choking hazard to small children.

### Uncrating

Tools Needed:  $\frac{3}{4}$ " box wrench, adjustable wrench, level, flat head screw driver, and box cutter.

1. Cut the stretch wrap along a corner post and remove the cardboard top capping and the corner posts.
2. Discard stretch wrap and any cardboard that will not be recycled.

---

*Note: additional clear plastic protective wrap is applied directly to any product with a glass door.*

---

3. Move unit as close to final position as possible before removing the skid.

---

*Note: The skid must be removed before the casters or legs can be attached.*

---

### Skid Removal and Caster Attachment

Tip the unit forward and remove the skid.



1. Remove the shipping bolts using the  $\frac{3}{4}$ " box wrench while cabinet is held in one direction. Repeat the process while the cabinet is held in the opposite direction.
2. None of the threads on the leg or caster stem should be visible once screwed in.
3. Tilt the cabinet in one direction approximately 8" and block it securely with pieces of 2x4 lumber or other suitable material.

4. While moving the unit, take extra caution to not push, pull, or strike the front or side glass.

### Leveling:

Cabinets must be leveled when installed. Level should be measured on the headrail.

---

*Note: If no casters, legs or levelers are to be installed, the floor below the equipment must be level*

---

Failure to level your cabinet may result in door not sealing, closing correctly, or condensed water draining not draining properly.

For cabinets with legs, rotate the foot of the leg with an adjustable wrench to achieve desired height for leveling.

For cabinets with casters, leveling can be achieved by placing large washers in between the  $\frac{1}{2}$ " stud and the holes located on the bottom of the case.



**Do NOT loosen casters to level the cabinet.** Casters MUST be tightly secured to cabinet for full strength.

Install or attach any accessories that will be used  
Remove any plastic covering the stainless steel.

## ELECTRICAL

This is a cord-connected unit, and must be connected to its own **dedicated** power supply. Check the dataplate on the machine to confirm the voltage and per the dataplate use the correct fuses or HACR circuit breakers.

---

*Note: Do not connect to GFI / GFCI outlets. Connection to that type of outlet can result in product loss due to unsafe cabinet temperature when GFI device trips from moisture.*

---

### Power Cord

This 120 volt model is equipped with a cord and a 5-15P plug.

If the power cord becomes damaged, it must be replaced with the identical cord.

The power cord of this appliance is equipped with a 3-prong (grounding) plug, which mates with a standard 3-prong (grounding) wall outlet to minimize the possibility of electric shock hazard from this appliance.

### Initial Start Up

Before connecting your equipment, check that the electrical data on the data plate matches your electrical output. If voltage varies by 10 percent or more, freezer performance may be affected. Operating the freezer with insufficient power can damage the compressor. Such damage is not covered by the warranty. If you suspect the voltage is too high or low, consult with your power company for testing.

Plug the power cord into the proper power supply.

The cabinet temperature has been set at the factory and should not be adjusted by unqualified personnel. For any adjustment, you must contact your distributor.

### Cautions

Unplug the freezer before cleaning and making repairs.

Care must be taken whenever moving or servicing the unit. The refrigerant is contained in a sealed system, but if released it may be flammable.

**PLUG THE EQUIPMENT INDEPENDENTLY TO A LOAD CENTER WITH AN APPROPRIATE CIRCUIT BREAKER ACCORDING TO THE NAMEPLATE AMPS.**

To prevent the freezer from being turned off accidentally, do not plug the unit into an outlet controlled by a wall switch or pull cord.

Do not pinch, knot, or bend the power cord in any manner.

### Follow All National and Local Codes

This Unit Must Be Grounded. Do not use extension cords and do not disable or by-pass ground prong on electrical plug.

### Electronic Temperature Control

To access the temperature control, the right side grill should be removed using a Phillips screw driver (see figure below).

The temperature control is factory pre-set to provide satisfactory product storage products. However, the temperature control is adjustable to provide a range of temperatures for your personal satisfaction. If a colder temperature is desired, turn the control clockwise. Allow several hours for the temperature to stabilize between adjustments.

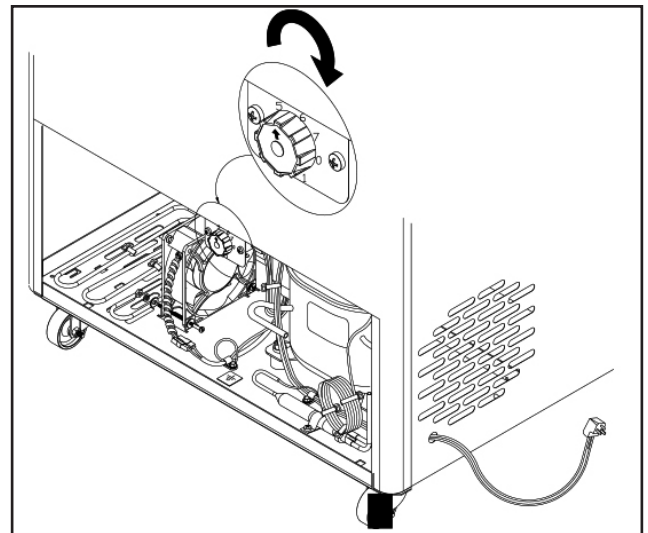

## ENVIRONMENTAL CONDITIONS

**THIS UNIT CANNOT BE INSTALLED IN ENVIRONMENTS WITH EXPLOSIVE GASES, IT IS DESIGNED ONLY FOR INDOOR OPERATION.**

### STORAGE OF THE EQUIPMENT:

- The unit must be located in an indoor environment. It is best suited for an environment where temperatures remain below 75°F and humidity doesn't exceed 55%.
- For the correct performance of the refrigeration system, it is very important to leave at least 4" of free space on both sides, and at the back of the unit to allow proper air circulation. Do not block the grills on the side or back of the unit.
- The location of the cooler must be kept away from sources of heat and humidity including direct sunlight, ovens, heaters, or any other heat generating appliances.
- If the equipment will be kept in storage, it is suggested to keep it in its original packing. If your equipment needs to be inactive for a long period of time, it should be unplugged and cleaned thoroughly with a damp cloth, lukewarm water, and neutral soap. Once clean, carefully dry the unit and cover it with a polyethylene film or similar waterproof material.

### LOADING THE EQUIPMENT:

The NC series of units are not intended to be pull down freezers, and as such, the product must be loaded at their intended merchandising temperature.

### **OVERLOADING THE FREEZER FORCES THE COMPRESSOR TO RUN LONGER. DO NOT EXCEED THE LOAD LIMIT ACCORDING TO LABELS FIXED ON THE INNER CABINET (WHICH CORRESPONDS TO THE BASKETS' HEIGHT)**

- Before loading products, allow the equipment to operate empty for at least four hours.
- Product to be loaded should be at -4°F since the equipment is intended for maintaining a cool product at 0°F at load level rather than freezing a warm product.
- The baskets have been designed to withstand the rigors of normal use. Avoid product overloading to prevent deforming the baskets.
- Keep the lids closed to avoid warm air and moisture getting into the freezer.

### MOVING THE EQUIPMENT:

**The unit is shipped with casters to facilitate moving the unit into position.**

- Before moving, disconnect the power cord plug from the wall outlet.
- Remove all product, then defrost and clean the unit.
- Secure all loose items such as baskets and fix the lids in place to prevent damage.
- If transporting, secure the freezer in an upright position in the moving vehicle, and cover it to protect the outside of the cabinet.

### REMOVAL OF FROST:

It is recommended to remove the frost accumulated before reloading the freezer or anytime when one quarter inch of frost has accumulated.

The unit will have to be manually defrosted. The manual defrost frequency will depend on the units usage, environment, and the amount of frost accumulated.

Make sure the drain plug is removed and the unit is moved close to a floor drain.

Unplug the unit until all the frost is gone.

When the ice has melted, wipe up any water left on the freezer floor.

Be sure to replace the drain plug before moving the freezer back into position.

Allow the freezer to refrigerate and cycle before placing the wire baskets and product back into freezer

To defrost while keeping the freezer plugged in, place a clean dry soft cloth over the product to catch the frost that will be removed. Remove the frost using a plastic scraper trying to eliminate as much frost as possible.

## CLEANING AND MAINTENANCE

**WARNING - DAMP OBJECTS STICK TO COLD METAL SURFACES. DO NOT TOUCH THE INTERIOR METAL SURFACES WITH WET OR DAMP HANDS.**

After defrosting, wash the inside surfaces of the freezer with a solution of two tablespoons of baking soda in one quarter of a gallon (1.1 liters) warm water. Rinse and dry. Wring excess water out of the sponge or cloth when cleaning in the area of the controls, or any electrical parts.

Wash the removable parts and door basket with the baking soda solution, or mild detergent and warm water. Rinse and dry. Never use metallic scouring pads, brushes, abrasive cleaners, or alkaline solutions on any surface. Do not wash removable parts in a dishwasher. Do not spray water with a hose nor use ammonia based cleaners.

**WARNING - THE LOWER SIDE OF THE GLASS LIDS IS PROVIDED WITH A SPECIAL FILM. DO NOT USE RAZOR BLADES OR OTHER SHARP INSTRUMENTS WHICH CAN SCRATCH THE SURFACE AND DAMAGE THE FILM**

### CLEANING THE OUTSIDE

- Wash the cabinet with warm water and mild liquid detergent. Rinse well and wipe dry with a clean soft cloth. Do not spray water onto the unit with a hose, or use ammonia based cleaners.
- Once a week, clean each external and internal surface with only a damp piece of cloth and neutral soap, and dry them with a clean soft cloth.
- Never use flammable or abrasive products. The unit must never be cleaned with jets of water.
- During maintenance and cleaning operations, make sure there are good visibility conditions in the working area, using as many light sources as needed. Be very careful when working with moving and/or high temperature parts.

### LID REMOVAL (IF REQUIRED)

- Stand in front of the freezer
- Assure that the lower lid is totally closed to the left side of the freezer.
- To remove the top lid, slide it open to it's maximum handling it by both sides, and push it toward the back. This allows the lid to get out from the front rail where it slides, then remove it pulling the lid out from the rear rail. Handle the lid carefully, and place it on a flat, secure surface.
- Repeat steps as needed.
- To install the lids again, reverse the previous steps starting with the lower lid.

## METHODS FOR CLEANING EXTERIOR FINISH

Cleaning Needed	Cleaning Agent	Method of Application	Affect on Finish
Smears and fingerprints	Areal 20, Lac-O-Nu, Lumin Wash O'Cedar Cream Polish, Stainless Shine.	Rub with cloth as directed on the package.	Satisfactory for use on all finishes. Provides barrier film to minimize prints.
Stubborn Spots and Stains, and Other Light Discolorations	Allchem Concentrated Cleaner.	Apply with damp sponge or cloth. Rub with damp cloth.	Use in direction of polish lines on No. 4 (polished) finish. May scratch No. 2 (mill) and Nos. 7 and 8 (polished) finishes.
	Samae, Twinkle or Cameo Copper Cleaner	Rub with damp cloth.	
	Grade FFF Italian pumice, whiting, or talc.	Rub with dry cloth.	
	Liquid NuSteel Paste NuSteel or DuBois Temp. Copper's Stainless Steel Cleaner Revere Stainless Cleaner Household cleansers, such as Old Dutch, Lighthouse, Sunbrite, Wyandotte, Bab-O, Gold Dust, Sapolio, Bon Ami, Ajax, or Comet Grade F Italian Pumice, Steel Bright, Lumin Cleaner, Zud, Restore, Sta-Clean, or Highlite. Penny-Brite or Copper-Brite.	Use small amount of cleaner. Rub with dry cloth using a small amount of cleaner. Apply with damp sponge or cloth. Rub with a damp cloth. May contain chlorine bleaches. Rinse thoroughly after use. Rub with a damp cloth. Rub with a dry cloth using a small amount of cleaner.	
Heat tint or discoloration	Penny-Brite or Copper-Brite. Past NuSteel, DuBois Temp, or Tarnite. Revere Stainless Steel Cleaner. Allen Polish, Steel Bright, Tenacious Deposits, Rusty Discolorations, Industrial Atmospheric Stains Wyandotte, Bab-O or Zud.	Rub with a dry cloth. Rub with a dry cloth or stainless steel wool. Apply with damp sponge or cloth. Rub with a damp cloth.	
Grease Fatty Acids, Milkstone (where swabbing or rubbing is not practical)	Easy-Off, De-Grease-It, 4 to 6% hot solution of such agents as trisodium phosphate or sodium tripolyphosphate or 5 to 15% caustic soda solution	Apply generous coating. Allow to stand for 10-15 minutes. Rinse. Repeated application may be necessary.	Excellent removal, satisfactory for use on all finishes.
Tenacious Deposits, Rusty Discolorations, Industrial Atmospheric Stains	Oakite No. 33, Dilac Texo 12, Texo NY, Flash-Klenz, Caddy Cleaner, Turco Scale 4368 or Permag 57.	Swab and soak with clean cloth. Let stand 15 minutes or more according to directions on package, then rinse and dry.	Satisfactory for use on all finishes
Hard Water Spots and Scale	Vinegar. 5% oxalic acid, 5% sulfamic acid, 5 to 10% phosphoric acid, or Dilac, Oakite No. 33, Texo 12, Texo N.Y.	Swab or wipe with cloth. Rinse with water and dry. Swab or soak with cloth. Let stand 10-15 minutes. Always follow with neutralizer rinse, and dry.	Satisfactory for all finishes. Effective on tenacious deposits or where scale has built up.



## FOR THE SERVICE TECH - R290

Refrigeration service should only be attempted by a trained trade professional certified to work on R290 systems.

### Here are some critical service items.

This list does not qualify anyone to service the unit. It is a reminder and checklist for the service tech. Keep these in mind for **R290** service:

- Wire nuts are **NOT** to be used when changing an electrical part.
- The switches in this product are sealed, **only exact replacements** may be used.
- The process tubes are to be used for service access.
- Cut out (with tubing cutter) refrigeration components that are to be replaced. Do **NOT** un-braze.
- Because R290 can be vented into the air during service, the venting **MUST** be in an area free from flame or spark. It must be near an opened window or door.
- A sign noting service of a system containing propane must be attached to the unit during refrigeration service.
- A combustible gas leak detector must be used to inform anyone in the area when propane is present in the air.

### Other Information:

**Evacuation:** It is critical that a refrigeration system be leak free and internally dry. A thorough evacuation with a good vacuum pump with a micron gauge attached is the only way to ensure that the system is dry and ready for a charge of refrigerant.

**Charging:** The system is critically charged and the proper type and amount **MUST** be weighed in.

**Overcharge symptoms:** Unit will cool properly but the suction line temperature will be unusually cold. Compressor run time will be longer than normal.

**Undercharge symptoms:** Long run time, poor cooling and a hot compressor dome are the main symptoms of an undercharge.

**POWER/FREEZE FAILURE**

**NOTE: DO NOT OPEN THE FREEZER DOOR UNNECESSARILY IF POWER TO THE FREEZER IS OFF FOR SEVERAL HOURS. IF A POWER FAILURE OCCURS, FROZEN FOODS WILL STAY FROZEN FOR AT LEAST 2 HOURS IF THE FREEZER IS KEPT CLOSED. IF THE POWER FAILURE CONTINUES, PACK SEVEN OR EIGHT POUNDS OF DRY ICE INTO THE FREEZER EVERY 24 HOURS. COVER THE PRODUCT WITH A CARDBOARD SHEET OR ONE INCH POLYURETHANE SHEET AND CLOSE THE LIDS. ALWAYS WEAR GLOVES AND USE CAUTION WHEN HANDLING DRY ICE.**

**IF THE FREEZER HAS STOPPED OPERATING, SEE "FREEZER DOES NOT RUN" IN THE SERVICE CHECKLIST SECTION OF THIS MANUAL. IF YOU CANNOT SOLVE THE PROBLEM, CALL AN AUTHORIZED SERVICE IMMEDIATELY. DO NOT ALLOW INEXPERIENCED PEOPLE TO REPAIR OR MODIFY THE ELECTRICAL WIRING AND/OR REFRIGERATION COMPONENTS.**

**BEFORE CALLING SERVICE, REVIEW THIS LIST. IT MAY SAVE YOU BOTH TIME AND COSTS. THIS LIST INCLUDES COMMON OCCURRENCES THAT ARE NOT THE RESULT OF DEFECTIVE WORKMANSHIP OR MATERIALS IN THIS APPLIANCE.**

OCCURRENCE	SOLUTION
Freezer runs too much or for too long	Check to ensure that the freezer is not plugged into a circuit that has ground fault interrupt - if you are unsure about the outlet, have it checked by a certified technician. Temperature control is in the OFF position - see "Setting the Temperature Control Section". Freezer may not be plugged in, or the plug may be loose - be sure the plug is tightly pushed into electric outlet. House fuse has blown, or the circuit breaker has tripped - check the circuit breaker and reset if needed, or replace fuse with a 15 amp time delay fuse. In case of power outage - call the local electric company.
Temperature inside the freezer is too low	Room or outside weather is hot - it's normal for the freezer to work harder under those conditions. Freezer was recently disconnected for a period of time - the freezer requires 4 hours to cool down completely. Large amounts of warm or hot product have been stored recently - warm product will cause the freezer to run more until the desired temperature is reached. Door is kept open too long or too frequently - warm air enters the freezer every time the door is opened, try to open the door less often. Freezer door may be slightly open. Temperature control is set too cold - turn the control knob to a warmer setting and allow several hours for the temperature to stabilize.
Temperature inside the freezer is too high	Temperature control is set too low - turn the control to a warmer setting and allow several hours for the temperature to stabilize
Temperature of external freezer surface is warm	Temperature control is set too high - turn the control to a colder setting and allow several hours for the temperature to stabilize. Door is kept open too long or is opened too frequently, which allows warm air to enter the freezer every time it is opened. - try to open the door less often. The door may be slightly opened. The freezer has recently been disconnected for a period of time - allow 4 hours to cool down completely.
Noise level is higher whenever the freezer is on	The exterior freezer walls can be as much as 30°F warmer than the room temperature. This is normal while the compressor works to transfer heat from inside the freezer cabinet.
Noise level is higher when the compressor comes on	The fan motor in the compressor compartment is damaged or has a loose connection. Modern freezers have increased storage capacity and more even temperatures, so they require a high efficiency compressor. So when the surrounding noise level is low, you may hear the compressor running while it cools the interior.
Popping or cracking sound when the compressor comes on	Freezer operates at higher pressure during the start of the ON cycle - this is normal, the sound will level off or disappear as the freezer continues to run.
Bubbling or gurgling sound, like water boiling	Metal parts undergo expansion and contraction, similar to hot water pipes - this is normal, the sound will level or disappear as the freezer continues to run.
Vibrating or rattling noise	Refrigerant (used to cool freezers) is circulating throughout the system - this is normal.
Moisture forms on the inside freezer walls	Freezer is not level, it may rock on the floor when it is moved slightly - level the unit. Floor is uneven or weak, freezer rocks on the floor when it is moved slightly - be sure the floor can adequately support the freezer. If so, level the freezer by placing either wood or metal shims under part of the freezer. Weather is hot, or humidity level is high, this increases the internal rate of frost build-up - this is normal. Door is slightly open, kept open too long, or is being opened too frequently - this causes the cold air from inside the freezer to meet the warm moist air from outside.
Odor inside the freezer	Interior needs to be cleaned - clean the interior according to the instructions in this manual. Products with strong odors are inside the freezer - cover the product tightly.



## LIMITED WARRANTY

### WARRANTY (Warranty valid in USA and Canada)

#### THREE (3) YEAR PARTS AND LABOR WARRANTY:

Beverage-Air Corporation warrants to the original purchaser of Beverage-Air branded equipment, including all parts thereof, that such equipment is free from defects in material and workmanship, under normal use, proper maintenance, and service as indicated by Beverage-Air installation and operation instructions, for a period of three (3) years from the date of installation, or thirty-nine (39) months from the date of shipment from the manufacturer, whichever is earlier.

#### ADDITIONAL TWO (2) YEAR COMPRESSOR PART WARRANTY\*:

In addition to the warranty set forth above, Beverage-Air warrants the hermetically/semi-hermetically sealed compressor (part only) for an additional TWO (2) years beyond the first THREE (3) years warranty period; not to exceed sixty-three (63) months from the date of shipment from Beverage-Air, provided upon receipt of the compressor, manufacturer examination shows the sealed compressor to be defective. This extended warranty does not cover freight for the replacement compressor or freight for the return of the failed compressor.

\* Units shipped after 07/01/2024. Previous warranty applies to units shipped prior.

#### EXCEPTIONS:

- CT96 and CF3 models carry a ONE (1) year parts and labor warranty, limited to fifteen (15) months from date of shipment from Beverage-Air. These are excluded from additional compressor warranty.
- SR/SF (Slate) models carry a TWO (2) year parts and labor warranty, limited to twenty-seven (27) months from date of shipment from Beverage-Air.
- BZ, VM, CDR, BDC, NC, DPCR, MT and Blast Chillers carry a THREE (3) year parts and labor warranty; additional TWO (2) years compressor part only.
- Units installed in Residential applications will be not covered under this warranty. Units are intended for Commercial use only.

Also, this compressor-part only warranty does NOT apply to any electrical controls, condenser, evaporator, fan motors, overload switch, starting relay, capacitors, temperature control, filter/drier, accumulator, refrigeration tubing, wiring harness, labor charges, or supplies which are covered by the warranty above.

Note: 3rd party extended warranties are not covered by this warranty statement.

Normal wear parts, as deemed by Beverage-Air, such as but not exclusive to, light bulbs/lamps and gaskets are not covered by this warranty. For the purpose of this warranty, the original purchaser shall be deemed to mean the individual or company for who the product was originally installed.

Units that utilize variable speed compressor technology can experience nuisance tripping on Class A GFCI outlets which have a trip limit of 4 mA to 6 mA. To avoid this issue in a location that requires GFCI circuit protection, Beverage-Air & Victory recommends using a HUBBELL Model Number GFRST83W 20A Heavy Duty Hospital Grade Self-Test GFCI Receptacle. Nuisance tripping not covered under warranty.

Our obligation under this warranty shall be limited to repairing or replacing, including labor, any part of such product, which proves thus defective. Beverage-Air reserves the right to examine any product claimed to be defective and request photos of the unit prior to dispatching service. Moisture or water damage is not covered under warranty. If service is deemed non-warranty, Beverage-Air reserves the right to bill the end user for service.

The labor warranty shall be for self-contained units only and for standard straight time, which is defined as normal service rate time, for service performed during normal working hours. All warranty labor will be covered at standard time. Any service requested outside of a servicer's normal working hours including weekends and any additional overtime will be at the responsibility of the equipment purchaser. Any part or accessory determined to be defective in the product should be returned to the company within thirty (30) days under the terms of this warranty and must be accompanied by a record of the cabinet model, serial number, and identified with a return material authorization number (RMA#) issued by the manufacturer.

**Special installation/applications, including remote locations, are limited in coverage by this warranty. Any installation that requires extra work, and/or travel, to gain access to the unit for service is the sole responsibility of the equipment purchaser.**

Improper operation resulting from factors, including but not limited to, improper or negligent cleaning and maintenance, improper installation, low voltage conditions, inadequate wiring, outdoor use (unless otherwise specified) and accidental damage are not manufacturing defects and are strictly the responsibility of the purchaser.

**LIMITED WARRANTY (CONT'D)**

With the exception of Blast Chillers, the product is designed for maintaining temperature and not bringing food to a desired temperature and therefore cannot be held responsible for this function under warranty. Units must be in a conditioned environment or warranty will be void. Non-standard use of unit can also be subject to reduced or voided warranty.

Condensing coils must be cleaned at regular intervals as a part of preventative maintenance for optimal performance. Failure to do so is subject to a voided warranty. Although cleaning requirements vary in accordance with operation of various products, Beverage-Air recommends a minimum monthly cleaning.

**NO CLAIMS CAN BE MADE AGAINST THIS WARRANTY FOR SPOILAGE OF FOOD, PRODUCTS, LOSS OF SALES OR CONSEQUENTIAL DAMAGES.**

THE FOREGOING WARRANTIES ARE EXPRESSLY GIVEN IN LIEU OF ALL OTHER WARRANTIES, EXPRESS, IMPLIED, OR STATUTORY, INCLUDING THE IMPLIED WARRANTIES OF MERCHANTABILITY AND FITNESS FOR A PARTICULAR PURPOSE, WHICH ARE HERBY DISCLAIMED, ALL OTHER OBLIGATIONS OR LIABILITIES ON OUR PART, AND WE NEITHER ASSUME, NOR AUTHORIZE ANY OTHER PERSON TO ASSUME FOR US, ANY OBLIGATION OR LIABILITY IN CONNECTION WITH THE SALE OF SAID REFRIGERATION UNITS OR ANY PARTS THERE OF.

This warranty shall not be assignable and shall be honored only in so far as the original purchaser. This warranty does not apply outside the limits of the United States of America and Canada, nor does it apply to any part that has been subject to misuse, neglect, alteration, accident, or to any damage caused by transportation, flood, fire, acts of terrorism, or acts of God.

**LIMITATION OF LIABILITY:**

Beverage-Air Corporation or their affiliates shall not be liable for any indirect, incidental, special or consequential damages, or losses of a commercial nature arising out of malfunction equipment or its parts components thereof, as a result of defects in material or workmanship.

THE ORIGINAL OWNER'S SOLE AND EXCLUSIVE REMEDY AND BEVERAGE-AIR'S SOLE AND EXCLUSIVE LIABILITY SHALL BE LIMITED TO THE REPAIR OR REPLACEMENT OF PARTS OR COMPONENTS CONTAINED IN THE EQUIPMENT IDENTIFIED ABOVE WHICH UNDER NORMAL USE AND SERVICE MALFUNCTION AS A RESULT OF DEFECTS IN MATERIAL OR WORKMANSHIP, SUBJECT TO THE APPLICABLE PROVISIONS AND LIMITATIONS STATED ABOVE.

Note: Additional Terms and Conditions of sale may apply. Notice: Specifications are subject to change without notice. Contact Beverage-Air for specific model agency approval. All prices are ex-works Brookville, PA. July 1, 2024

**Warranty Registration**

Register your product online at [beverage-air.com/parts-service](http://beverage-air.com/parts-service) or fill out and mail the form below.

Cabinet Model Number: \_\_\_\_\_ Date Of Installation: \_\_\_\_\_

Cabinet Serial Number: \_\_\_\_\_

**Location Of Product**

Business Name: \_\_\_\_\_

Business Street: \_\_\_\_\_

Business City: \_\_\_\_\_ State: \_\_\_\_\_ Postal Code: \_\_\_\_\_

**Mail to:** Beverage-Air, 3779 Champion Blvd, Winston-Salem, NC 27105

Rev. 02/26

