

# SEARS

## OWNER'S MANUAL

Model No.  
390.307060



**CAUTION:**  
Read and Follow  
All Safety Rules and  
Operating Instructions  
Before First Use of  
This Product.

Save This Manual For  
Future Reference.

## CRAFTSMAN® BATTERY OPERATED BACKUP SUMP PUMP

- Safety Instructions
- Operation
- Installation
- Troubleshooting
- Repair Parts

Sears, Roebuck and Co., Hoffman Estates, IL 60179 U.S.A.

## CONTENTS

Introduction/Warranty .....	2
Safety .....	2
Performance .....	3
Charger Operation.....	3
Battery Requirements .....	4
Installation/Operation .....	4-5
Electrical .....	5-6
Service/Troubleshooting .....	6-7
Repair Parts.....	7

## INTRODUCTION

Please take a few minutes to read our instructions before installing your Backup Sump Pump. It will help to assure perfect installation and help you avoid needless service expenses.

## IMPORTANT SAFETY INSTRUCTIONS for BATTERY CHARGER

**▲ WARNING** Risk of electrical shock, fire, or explosion. Read all instructions in owner's manual and on charger, pump, and battery before using battery charger.

1. Unplug battery charger before attempting any cleaning.
2. Charge only rechargeable 12-volt lead-acid batteries.
3. Do not let charger get wet.
4. Use only attachments recommended or sold by battery charger manufacturer.
5. When unplugging charger, grasp plug (not cord) to avoid risk of damage to cord or plug.
6. Locate cord so that it cannot be stepped on, tripped over, damaged, stretched, or flooded.
7. Do not modify cord or plug.
8. Do not attempt to service charger; it has no user-serviceable parts. If charger is dropped, struck, or otherwise damaged, replace the charger.

## SAVE THESE INSTRUCTIONS

### FULL ONE YEAR WARRANTY ON CRAFTSMAN® BATTERY BACK-UP SUMP PUMP

For one year from the date of purchase, Sears will repair or replace this pump, free of charge, if defective in materials or workmanship.

### LIMITED WARRANTY ON CRAFTSMAN® BATTERY BACK-UP SUMP PUMP

After one year and through two years from the date of purchase, Sears will furnish, free of charge, a replacement part for any defective part. You pay for labor.

This warranty does not cover repairs on replacement parts necessary because of abuse or negligence including failure to install, adjust and operate this pump according to the instructions in the owner's manual.

### LIMITATION OF LIABILITY

**SEARS WILL NOT BE LIABLE FOR LOSS OR DAMAGE TO PROPERTY OR ANY INCIDENTAL OR CONSEQUENTIAL LOSS OR EXPENSE FROM PROPERTY DAMAGE DUE DIRECTLY OR INDIRECTLY FROM THE USE OF THIS PRODUCT.**

Some states do not allow the exclusion or limitation of incidental or consequential damages, so the above limitation or exclusion may not apply to you.

**WARRANTY SERVICE IS AVAILABLE BY SIMPLY CONTACTING THE NEAREST SEARS SERVICE CENTER/DEPARTMENT IN THE UNITED STATES.**

This warranty applies only while the product is in the United States.

This warranty gives you specific legal rights, and you may also have other rights which vary from state to state.

Sears, Roebuck and Co., Dept. 817 WA, Hoffman Estates, IL 60179

## RULES FOR SAFE INSTALLATION AND OPERATION

Carefully read and follow all safety instructions in this manual or on pump.

**▲** This is the safety alert symbol. When you see this symbol on your pump or in this manual, look for one of the following signal words and be alert to the potential for personal injury!

**▲ DANGER** DANGER warns about hazards that will cause serious personal injury, death or major property damage if ignored.

**▲ WARNING** WARNING warns about hazards that can cause serious personal injury, death or major property damage if ignored.

**▲ CAUTION** CAUTION warns about hazards that will or can cause minor personal injury or property damage if ignored.

The word NOTICE indicates special instructions which are important but not related to hazards.

1. To avoid risk of serious bodily injury due to electrical shock or burns and property damage due to flooding, read the safety instructions carefully before installing pump.

**▲ WARNING** Battery acid is corrosive. Do not spill on skin, clothing, or battery charger. Wear eye and head protection when working with battery. Connect and disconnect DC output terminals only after removing the charger from the AC outlet. Never allow the DC terminals to touch each other.

**▲ WARNING** Hazardous voltage. Can cause severe or fatal electrical shock. Do not plug in or unplug battery charger while standing on a wet floor or in water. Be sure one hand is free when plugging in or unplugging charger. If basement floor is wet, disconnect power to basement before walking on floor.

**▲ CAUTION** Risk of flooding. Do not run pump dry. To do so will damage seals and can cause leaking and property damage.

2. Follow local and/or national plumbing and electrical codes when installing the system. A ground fault circuit interrupter (GFCI) is recommended for use on any electrical appliance submerged in water.
3. Use this system only for backup sump pump duty in a residential application. It is not designed as a primary sump pump.
4. Do not lift pump by electrical cord.

**▲ WARNING** Risk of electrical shock. Do not lift the pump by the electrical cord; lift pump only by the discharge pipe, lifting ring or handle on the pump. Lifting by the cord can damage the cord.

5. Pump clear water only with this pump.
6. Pump is permanently lubricated at the factory. Do not try to lubricate it!
7. Keep battery charger and battery box off of the floor and in a dry, cool, well ventilated area.  
**NOTICE:** If a Carbon Monoxide (CO) sensor is installed, it must be at least 15 feet away from battery charger in order to avoid nuisance CO alarms. Please refer to your CO detector's installation guidelines for more information.
8. To avoid danger of fire or explosion, keep sparks and flame (pilot light) away from battery.
9. Maximum vertical pumping distance is 15 feet (4.6M).
10. Make sure sump is clear of debris. Debris can damage the pump which can result in flooding.

## GENERAL INFORMATION

The Battery Back-up Sump System is not a substitute for your primary sump pump. It is designed to temporarily back up your primary sump pump during a power outage or other problem which prevents normal operation of the primary pump. Do not use this system to pump flammable liquids or chemicals. Pump clear water only with this pump.

Keep battery charger dry and protected from damage.

In an emergency (such as an extended power outage) which depletes the system's deep cycle marine battery, your automobile battery may be temporarily substituted. Be sure to replace the deep cycle marine battery as soon as possible. Use of an automobile battery instead of a deep cycle marine battery in this system will significantly reduce system performance. Automobile batteries are not designed for this type of application.

**NOTICE:** This unit is not designed for applications involving salt water or brine! Use with salt water or brine will void warranty.

## BATTERY BACKUP SYSTEM INSTALLATION AND OPERATION

**NOTICE:** Install this system during a time when the primary pump will not be needed. Gather all supplies before starting. Read all warnings and installation steps before you start.

**NOTICE:** Be prepared for water to leak from the coupling or piping when disassembling or cutting the discharge pipe. Protect system components, tools and supplies from getting wet. Dry any work areas that get wet.

## BASIC TOOLS AND MATERIALS NEEDED

- Slip-joint or large pliers
- Tape measure
- Socket wrench or 5/16" nut driver
- Side cutters
- Hacksaw (to cut PVC pipe)
- Medium size pliers
- Pencil
- Teflon tape
- PVC glue (solvent weld) and primer
- Cloth towel
- 24M Deep Cycle Marine Battery  
or a
- 27M Deep Cycle Marine Battery

**▲ WARNING** Personal injury and flood hazard. Do not turn the pump on until all the fittings are glued and the glue has dried. Loose fittings can explode off the pipes and cause personal injury and flooding.

### Remove Primary Pump From Sump Pit:

1. Locate the "on" water level of the primary sump pump. Mark this location on the discharge pipe with a pencil. See Figure 1.
2. Drain the sump and unplug the pump. The water level must be pumped down as low as possible before going on to the next step.

**▲ WARNING** Electrical shock hazard. Shock can burn or kill. Do not make contact with the remaining water in the sump pit. Unplug the primary sump pump and any accessories such as alarms before you continue. Failure to follow this warning can result in personal injury or death.

3. To separate the primary pump from the discharge pipe:
  - A. For applications with rubber couplings: remove the coupling clamp with a nut driver, and be prepared for water to spill out.
  - B. For applications without rubber couplings: cut the PVC discharge pipe with a hacksaw above the basement floor and at a comfortable level. Be prepared for water to spill out. New rubber couplings are included for reassembly.

**CAUTION** Risk of pinching hands or fingers. To avoid a hand injury from a collapse of plumbing, support the pipe above the separation before cutting or disassembly.

4. Lift the primary pump and discharge pipe assembly out of the sump.

**WARNING** Risk of electrical shock. Do not lift the pump by the electrical cord; lift pump only by the discharge pipe, lifting ring or handle on the pump. Lifting by the cord can damage the cord.

**NOTICE:** The discharge pipe is filled with water. Drain the water from the discharge pipe assembly. Keep the work area dry.

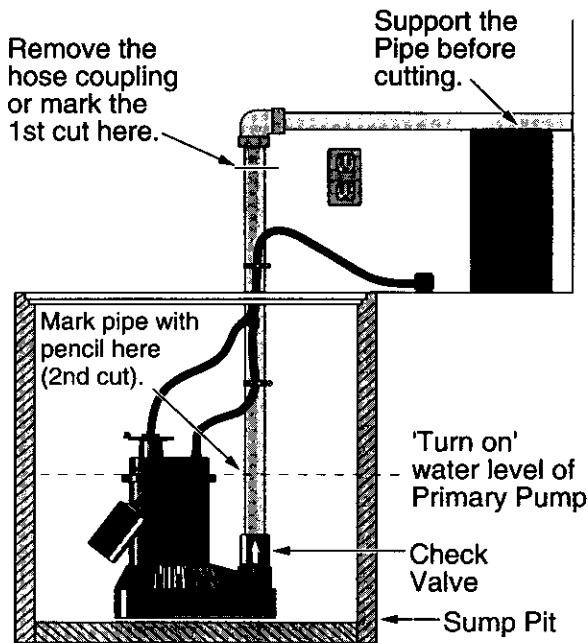

Figure 1 – Mark and cut the pipe as shown

## INSTALL BACKUP PUMP

Refer to the Exploded View on Page 9 for Key Numbers

1. Make a second cut in the discharge pipe at the pencil mark made in step 1 and set the cut-off piece of discharge pipe aside. See Figure 2.

2. Wrap the threads of the close nipple (Key No. 5, Page 9) counterclockwise with 2 turns of teflon tape and set aside.

**NOTICE:** There must be a check valve installed in the Primary Sump Pump discharge between the tee and the Primary Sump Pump. This will prevent recirculation into the Primary Pump when the Back Up Sump Pump comes on. See Figure 2.

3. The backup pump (Key No. 7, Page 9) and coupling and check valve assembly (Key No. 6, Page 9) come pre-assembled. Thread the close pipe nipple into the check valve and pump assembly.

4. Thread the tee (Key No. 3, Page 9) into the close nipple.

5. Hold the coupling (Key No. 6, Page 9) with the channel locks, insert the screwdriver into the tee for leverage and tighten the tee with the screwdriver. Finish with the tee in a straight up and down (vertical) position.

6. Clean the pipe ends with the cloth towel.

7. Glue the cut-off piece of discharge pipe into the top of the tee. If your pipe is 1-1/4", you will need to glue the reducer bushings into the tee and glue the pipe into the bushings. Place the assembly on to the primary discharge pipe. Do not glue the tee onto the Primary Pump discharge pipe.

8. Mount the float switch assembly (Key No. 9, Page 9) loosely to the discharge pipe with the cable ties (Key Nos. 9A & 9B, Page 9). Approximately 3" (76mm) of cord length should be left between the float and the clamp. Adjustments may be needed, do not tighten the cable ties. See Figure 3, Page 5.

### Backup Pump and Check Valve Assembly

Not to Scale  
Switches and Wiring omitted for clarity

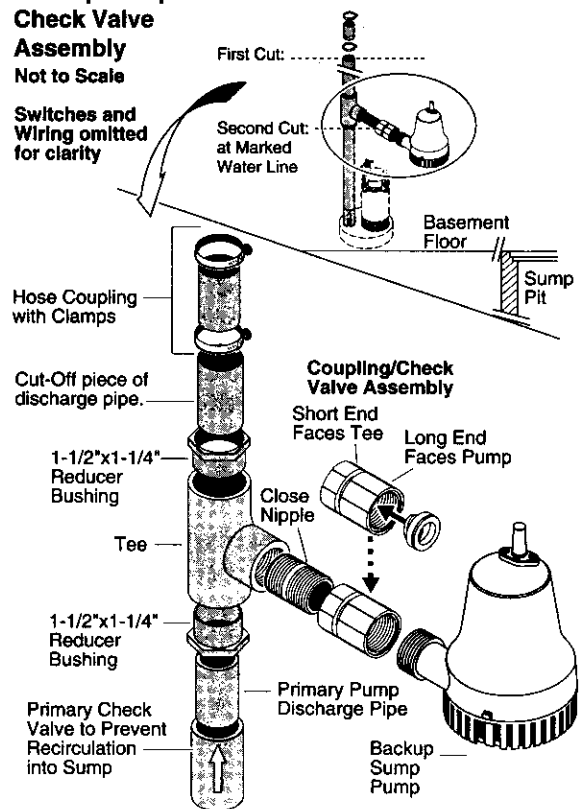

Figure 2 – Make the second cut for installation of the backup pump and check valve assembly. Install the backup pump. Your installation may not require the reducer bushings.

### Installation of Double Pump Assembly in Sump Pit:

1. Put the double pump assembly back into the sump pit.

**NOTICE:** The discharge pipe now overlaps the discharge pipe leading outside.

2. Mark the discharge pipe where it should be cut. Be sure to leave a 1/4" air gap between the ends of the pipes. This gap will absorb noise from vibration and allow for flexibility. See Figure 4, Page 5.

## Trial Assembly of Double Pump Assembly in Sump Pit:

1. Connect the pump discharge pipe to the exterior discharge pipe with the rubber coupling and clamp kit (Key No. 2, Page 9). Do not tighten the clamps until all the final adjustments are complete. See Figure 3.

**NOTICE:** For 1-1/2" discharge pipe, remove the inner section of hose from the rubber coupling.

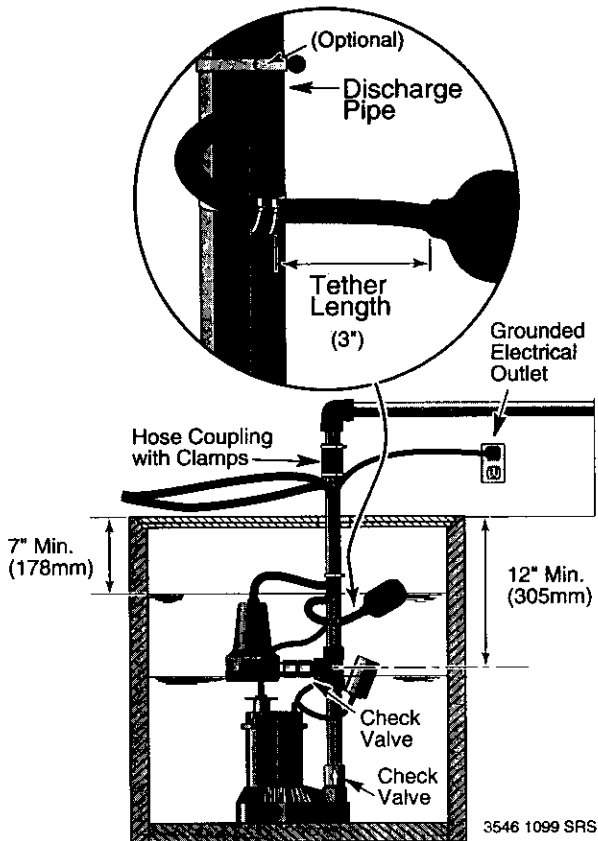

**Figure 3 – Double pump and float switch installation**

2. Make the final adjustments. Make sure the pumps and the switches do not interfere with each other. Make sure there is plenty of room for the float switches to swing from their "off" to their "on" positions.

### Mark and Glue Assembly:

1. Mark the pipe and the fittings at all the connections with a pencil. These marks will be used as a reassembly guide while gluing to be sure that everything is still in the right place and nothing has moved.
2. Loosen the rubber coupling and clamp connection.
3. Carefully pull the double pump assembly back out of the pit.

4. Take the tee assembly off of the primary discharge pipe. Do not take the tee off of the threaded assembly.
5. Clean all the PVC pipe ends with the PVC cleaner.

**▲WARNING** Hazardous fumes. Follow the cement and cleaner manufacturers instructions. Use the PVC cement in a well ventilated area away from fire or flames.

6. Glue the PVC fittings where indicated by the pencil marks. Wait 10 minutes for the glue to cure.

### Final Assembly:

1. Put the double pump assembly back into the pit. See Figure 4.

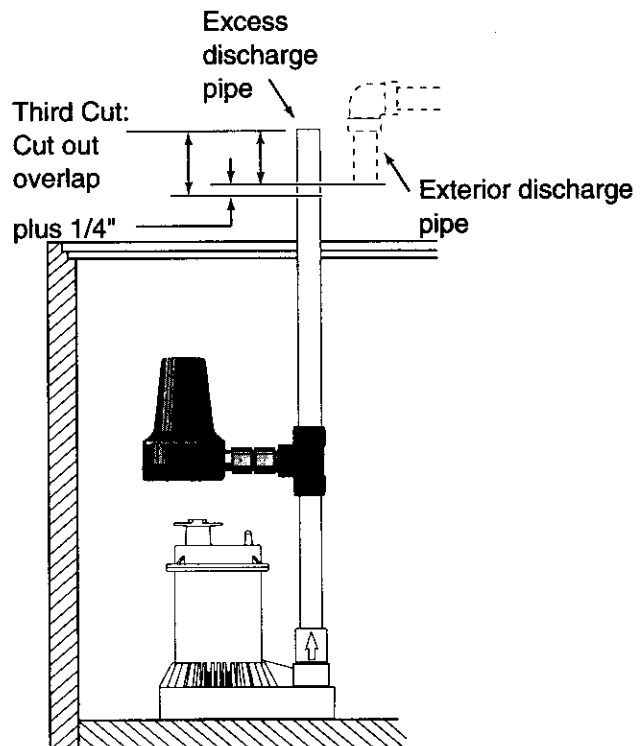

**Figure 4 – Make a third cut to remove the excess discharge pipe**

2. Install and tighten the rubber coupling and clamp kit.
3. Make the final float switch adjustments and tighten the cable ties.

## ELECTRICAL CONNECTIONS

**▲WARNING** Hazardous voltage. Can cause serious or fatal electrical shock. Review safety instructions before operating charge. Do not modify cord or plug.

# CHARGER/BATTERY INSTALLATION

**NOTICE:** An alarm, located in the junction box, automatically sounds when the system runs if the alarm is in the "Enable" position. The alarm is silenced when the alarm switch is in the "Disable" position.

1. Apply two pieces of two-sided tape (provided, Key No. 11, Page 9) to the back of the junction box. Press the junction box onto the battery box as illustrated in Figure 5 (below) and on Page 9 (Exploded View).
2. Connect the charger as shown in Table I and Figure 5.

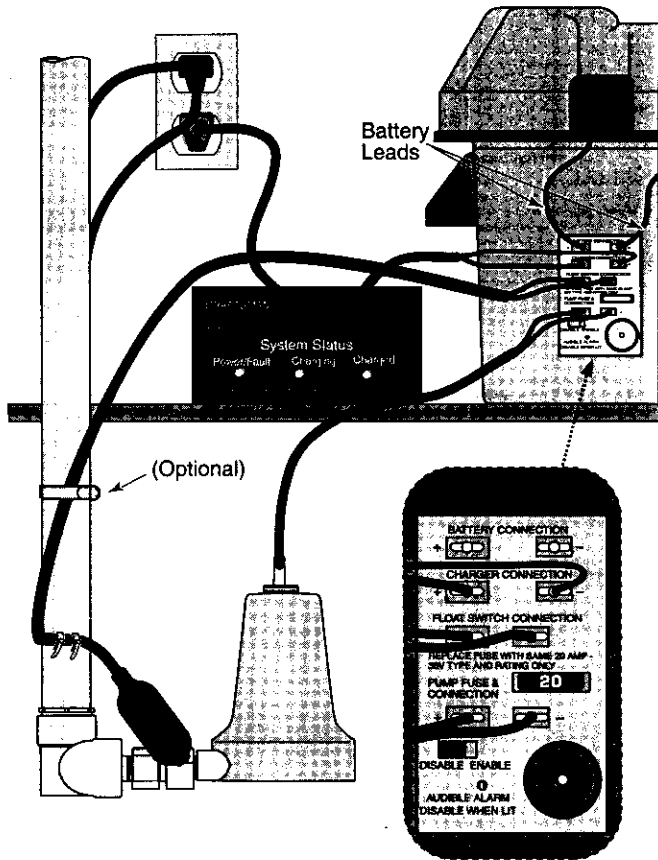

**Figure 5 - Wiring Connections**

3. Plug the charger into a 115-120 Volt AC outlet delivering at least 15 amps. **Do not use a switch controlled outlet.** Mark circuit in main power panel "Backup sump pump power supply; do not turn off".

**TABLE I - Wiring Connections**

Connect the	To the Junction Box's
Positive (+) lead from the battery	Positive battery connection
Negative (-) lead from the battery	Negative battery connection
Positive lead from the charger	Positive charger connection
Negative lead from the charger	Negative charger connection
Backup sump pump float switch (2 wires)	Float switch connection (2 wires)
Positive lead from the pump	Positive pump connection
Negative lead from the pump	Negative pump connection

4. With the charger properly connected and plugged in, the panel on the front of the charger will show one of the following conditions (See Figure 6).

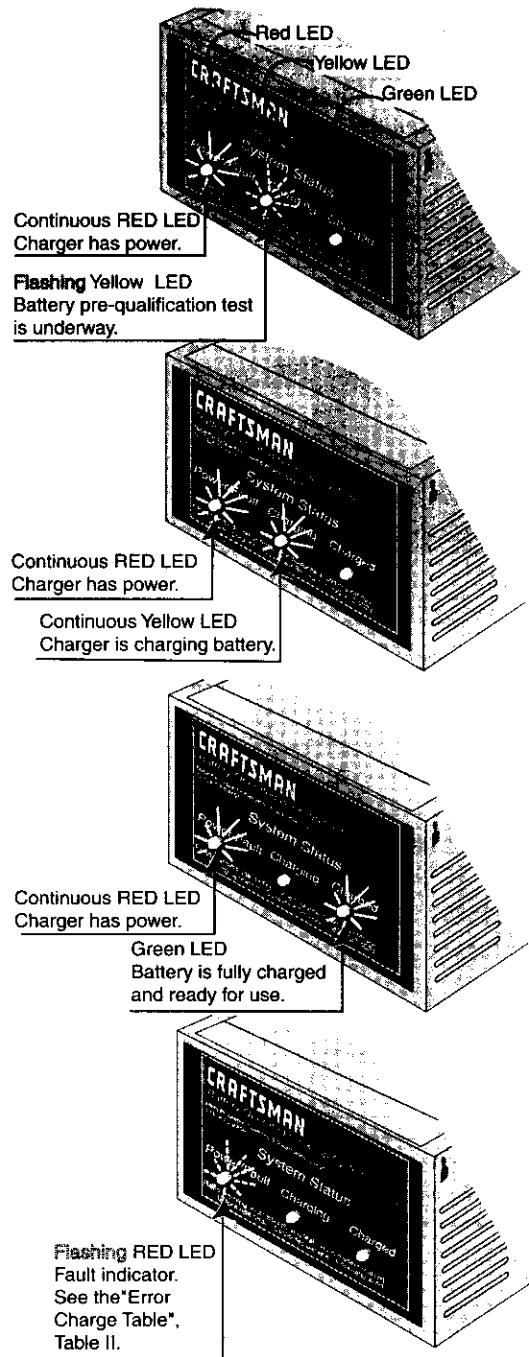

**Figure 6 - LED Panel**

**TABLE II - Error Charge Table**

<b>Flashing Red - "Fault" LED:</b>	A. Charger output lead connections are reversed.
	B. Battery has failed the pre-qualification test.
	C. Charging process has stopped. A new battery maybe needed.
	D. Battery terminal voltage is too low. Need new battery.

## Test the Assembly:

1. Plug the primary pump into a properly grounded 3-prong outlet.
2. Fill the sump with water to start the primary pump. Check for leaks.
3. Unplug the primary pump and fill the sump with water to start the backup system pump. Check for leaks.
4. Plug the primary pump back into a properly grounded 3-prong outlet. The system is now ready for operation.

## CHARGER OPERATION

The backup pump will activate automatically and an alarm will sound when the backup sump water level rises far enough to trip the float switch.

If the power to the charger circuit is interrupted, the length of time that the backup pump will run depends on the Ampere-hour capacity of the battery used, the battery charge level, the required vertical pumping distance, and the size of the sump.

Extended periods of operation (for example, during an extended power outage) may exhaust the battery. The battery charger will begin charging the battery as long as the battery has a voltage differential of 3 Volts or more.

### Recharge Time:

It will take approximately 43 hours to fully recharge a 24M battery in a "discharged battery condition". The approximate recharge time for the 27M battery is 56 hours. Industrial standards define a "discharged battery condition" as 10.5 Volts or less.

### The 5 Stages of the Charging Process:

**NOTICE:** All LED's will illuminate once the AC power has been applied. They will not light up if the charger is not plugged in. The RED LED will remain on continuously to indicate power to the charger. See Figure 6.

1. **Flashing yellow LED light:** Battery prequalification test stage. Normal duration of this stage is from 40 seconds to 3 hours.
2. **Continuous Yellow LED light:** Constant current charge stage. Charger is charging battery at the full rated output.

3. **Continuous Yellow LED light:** Constant voltage charge stage. Cells are being equalized.
4. **Green LED light:** Float charge stage. Battery terminal voltage has been regulated and system is ready for use. Charging has stopped.
5. **Recycle charge stage.** Charger will automatically initiate a charge cycle that begins with the prequalification test stage. This occurs once the battery has been in the float charge stage for 28 days.

### Special Features:

- The charger is equipped with reverse battery, short circuit, and "run-away charge" protection.
- A built-in safety timer starts when the charger enters the Constant Current/Constant Voltage Charge stage (Yellow LED is continuously on). The system has a 70 hour safety timer.
- To reset the charger simply unplug it from the 120V outlet for 10 seconds and then plug it back in.

## BATTERY REQUIREMENTS

**▲ WARNING** Hazardous electrical current. Can cause severe burns and start a fire if battery terminals are short circuited. Install battery in a battery box (See Key No. 10, Page 9). To prevent accidental shorting across battery terminals, strap cover securely (See Figure 7) on the battery box. Do not leave battery uncovered. Do not allow children to play around the battery backup system installation.

Your backup sump pump depends on the battery used with it for power. The better the battery, the better the performance of the pump. We recommend the use of a size 27M Deep Cycle Marine Battery or a size 24M Deep Cycle Marine Battery. They will perform as indicated in Table III, below, and stand up well to long periods of little or no use.

Use of a standard automobile battery with this charger is not recommended. An automobile battery may require charging after only 1-2 hours of continuous use, and the repeated charging cycles may cause early plate failure in the battery.

Use only the recommended battery or one of the same type and size so it will fit in the battery box (maximum size 12-5/8" long, 7" wide and 9-3/8" high [320.7mm x 177.8mm x 238mm] including terminals) and supply enough voltage for full performance.

**TABLE III – Capacity Ratings with a 24M or 27M Deep Cycle Marine Battery**

	VERTICAL PUMPING DISTANCE					
	8 FEET		10 FEET		12 FEET	
Battery Size	27M	24M	27M	24M	27M	24M
Gallons Per Minute	18.0	18.0	14.5	14.5	11.5	11.5
Hours Available	12.0	9.5	13.5	10.5	14.5	11.5
Total Gallons Pumped	10,520	8,402	10,422	8,339	5,876	4,516
Recharge Time	56.0	43.0	56.0	43.0	56.0	43.0

\* These flow rates were obtained with a constant 12.7 VDC battery source. The average GPH will vary due to a reduction in output voltage from battery.

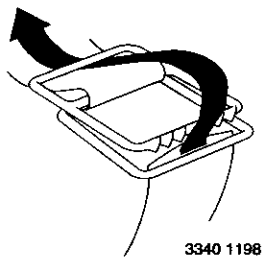

**Figure 7 – Battery Hold-down Strap Threading**

## BATTERY MAINTENANCE

**▲ WARNING** Severe burn hazard. A filled battery contains sulfuric acid. Avoid contact with skin, eyes or clothing.

**NOTICE:** To protect battery case from chipping and gouging, do not let battery sit on concrete floor. Install battery on a shelf or protective pad (plywood, 2x4s, etc.). Always install battery in a dry location that is protected from flooding.

Follow the battery manufacturer’s recommendations for maintenance and safe use of battery.

## TROUBLESHOOTING

### Pump won’t run.

1. Check all connections.
2. Check for low or defective battery.
3. Check that automatic switch is free to swing up and down.
4. Check for blown fuse in the junction box of the system.

### Motor hums but pump won’t run:

1. Check for low or defective battery.

### Pump runs but pumps very little or no water:

1. Make sure a check valve is installed and functioning between primary pump discharge and Backup Sump Pump tee.
2. Check for obstruction in discharge pipe.
3. Discharge pipe length and/or height exceeds capacity of pump. See Table III, Page 7, for pump capacity.
4. Check for low or defective battery.
5. Positive (+) and negative (-) wires reversed.

### Pump cycles too frequently:

1. The tether length too short on automatic float switch. Make sure that tether is at least 3" (76mm); see Figure 3, Page 5.
2. The main check valve located between discharge of primary pump and the Backup Sump Pump tee is not installed or working properly. Install or repair as required.

# Craftsman Battery Backup Sump Pump Model 390.307060

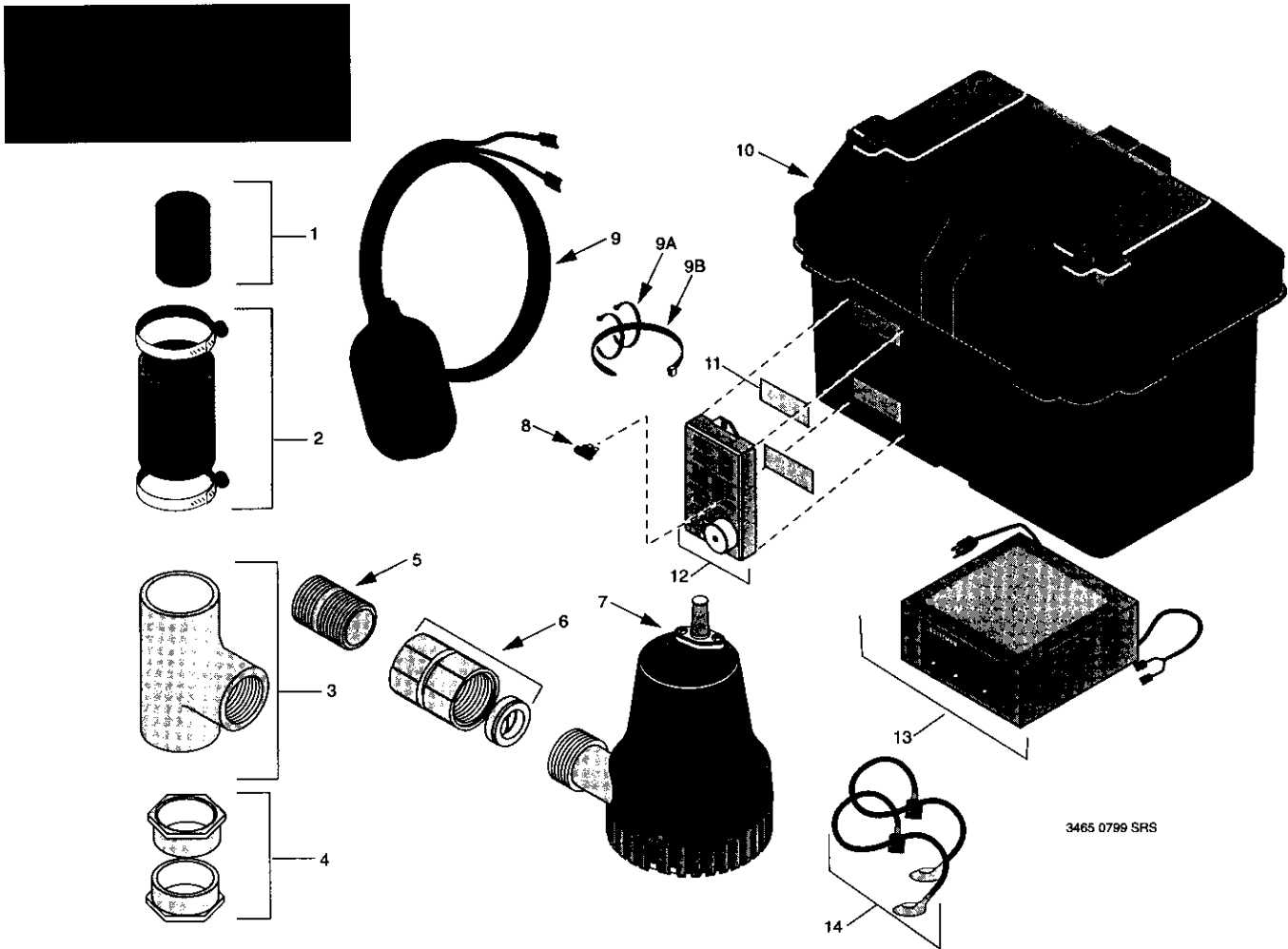

## REPAIR PARTS LIST

Key No.	Part No.	Part Description
1	U74-72	Hose Insert
2	U74-68	Rubber Hose Coupling and Clamps
3	U78-846P	PVC Tee 1-1/2 x 1-1/2 Slip x 1-1/4 FNPTW/1-1/4
4	U78-876P	Reducer Bushing (Requires 2)
5	U37-66P	PVC Pipe Nipple, 1-1/4 NPT x Close
6	ZB902110	Coupling, 1-1/4 FNPT x 1-1/4 FNPT and Check Valve Assembly
7	PS17-118	DC Backup Pump
8	*	Replacement Fuse, - ATO 20 Amp, 12 Volt
9	PS117-120P	Float Switch - 1/2HP, 8', 16 Gauge
9A	*	Small Cable Ties (2)
9B	*	Large Cable Tie
10	PS17-100	Battery Case (Complete with Strap)
11	PS97-5	Two Face Tape, 1" x 2" (†)(Requires 2)
12	PS17-113	Junction box
13	PS217-130	Charger Kit (includes wires)
14	PS117-114	Battery Leads (1 Pair)

† Included in Fittings Package.

\* Standard Hardware Item; can be purchased locally.





# SEARS

## OWNER'S MANUAL

**Model No.**  
390.307060

The model number of your Backup Sump Pump will be located on the pump, not the battery charger.

When requesting service or ordering parts, always give the following information:

- Product Type
- Model Number
- Part Number
- Part Description

# CRAFTSMAN<sup>®</sup> BATTERY OPERATED BACKUP SUMP PUMP

**For the repair or replacement parts you need**  
Call 7 am - 7 pm, 7 days a week  
**1-800-366-PART**  
(1-800-366-7278)

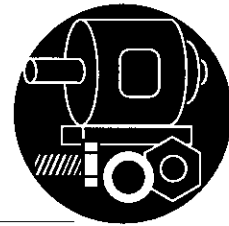

**For in-home major brand repair service**  
Call 24 hours a day, 7 days a week  
**1-800-4-REPAIR**  
(1-800-473-7247)



**For the location of a  
Sears Repair Service Center in your area**  
Call 24 hours a day, 7 days a week  
**1-800-488-1222**



**For information on purchasing a Sears  
Maintenance Agreement or to inquire  
about an existing Agreement**  
call 9 am - 5 pm, Monday-Saturday  
**1-800-827-6655**



**SEARS**  
**REPAIR SERVICES**  
*America's Repair Specialists*

Sears, Roebuck and Co., Hoffman Estates, IL 60179 U.S.A.