



SIMPSON

SM1200

SANITIZING MISTER AND PRESSURE WASHER SYSTEM

INSTRUCTION MANUAL



If your pressure washer is not working properly or if there are parts missing or broken, please **DO NOT RETURN IT TO THE PLACE OF PURCHASE**. Contact our Customer Service Department at **1-877-362-4271** or **www.simpsoncleaning.com**

IMPORTANT: Please make certain that the person who is to use this equipment carefully reads and understands these instructions before operating.

SAVE THIS MANUAL FOR FUTURE REFERENCE

SM1200 Sanitizing Mister and Pressure Washing System

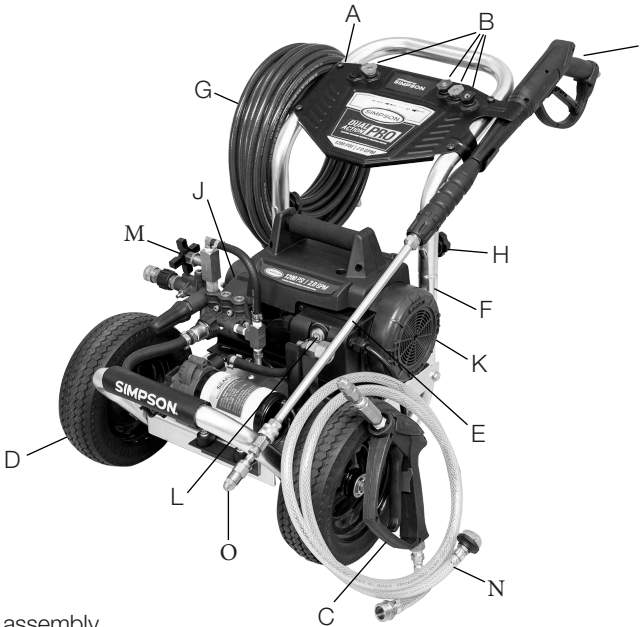

- A. Panel assembly
- B. Nozzle holders
- C. Mister spray gun
- D. Wheel
- E. Quick-connect spray wand
- F. Frame
- G. High-pressure hose
- H. Handle assembly
- I. Spray gun
- J. High-pressure pump
- K. Motor
- L. ON/OFF Switch
- M. Dual-Action Metering Valve
- N. Supply hose
- O. Mister nozzle

Pump

For best results, pump oil designed specifically for pressure washers is recommended, as these contain a rust inhibitor and an anti-foaming agent. If this oil is not available, an SAE 15W-40 oil may be used.

Specifications

MODEL	SM1200
Rated Pressure *	1200 psi
Rated Water Flow * Mister Pressure *	2.0 gpm 80 psi
Mister Flow *	.02-.06 gpm
Max water temp	90 °F/32 °C
Electrical Requirements	120V, 13.5 A, 60 Hz
GFCI Power Cord	35 ft. (10.6 m)
High-Pressure Hose	75 ft. (22.8 m)
Supply Hose	5 ft. (1.5 m)
Minimum Amp Source	15 A
Pressure of Inlet Water	20–100 psi
Inlet Water	cold tap (100 °F max)
Soap Consumption Rate	10% max soap injector/nozzle

*Rated Pressure and Rated Water Flow is within manufacturing tolerance of (10%).

In a continued commitment to improve quality, the manufacturer reserves the right to make component changes, design changes, or specification changes when necessary and without notice.

Definitions: Safety Guidelines

The definitions below describe the level of severity for each signal word. Please read the manual and pay attention to these symbols.

▲ DANGER: Indicates an imminently hazardous situation which, if not avoided, **will** result in **death or serious injury**.

▲ WARNING: Indicates a potentially hazardous situation which, if not avoided, **could** result in **death or serious injury**.

▲ CAUTION: Indicates a potentially hazardous situation which, if not avoided, **may** result in **minor or moderate injury**.

NOTICE: Indicates a practice **not related to personal injury** which, if not avoided, **may** result in **property damage**.

IF YOU HAVE ANY QUESTIONS OR COMMENTS ABOUT THIS MACHINE CONTACT US AT: **www.simpsoncleaning.com** or **1 (877) 362 4271**

▲ WARNING: Please read this entire manual before attempting to assemble, operate or install the product.

▲ WARNING: This unit was designed for specific applications. It should not be modified and/or used for any application other than which it was designed for.

NOTICE: Always store your pressure washer in a location where the temperature will not fall below 40 °F (4 °C). Freeze damage is not covered by the warranty.

▲ WARNING: This product contains chemicals known to the State of California to cause cancer, and birth defects or other reproductive harm. In addition, some cleaning products and contain chemicals know to the State of California to cause cancer, and birth defects or other reproductive harm. **Wash hands after handling.**

READ AND SAVE THESE INSTRUCTIONS

IMPORTANT SAFETY INSTRUCTIONS

▲ WARNING: When using this product basic precautions should always be followed, including the following:

1. Read all the instructions before using the product.
2. To reduce the risk of injury, do not operate near children or animals.
3. Know how to stop the product and bleed pressures quickly. Be thoroughly familiar with the controls.
4. Stay alert - watch what you are doing.
5. Do not operate the product when fatigued or under the influence of alcohol or drugs.
6. Keep operating area clear of all persons.
7. Do not overreach or stand on unstable support. Keep good footing and balance at all times.
8. Follow the maintenance instructions specified in the manual.
9. This product is provided with a Ground Fault Circuit Interrupter built into the power cord plug. If replacement of the plug or cord is needed, use only identical replacement parts.
10. Do not touch plug or outlet with wet hands.
11. Avoid accidental starts. Move switch to the OFF position before connecting or disconnecting cord to electrical outlets.
12. Water spray must never be directed towards any electric wiring or directly towards the pressure washer machine itself, as fatal electric shock may occur.
13. Never carry your pressure washer by the cord. Do not pull on the cord to disconnect from the outlet.
14. To prevent damage, the cord should not be crushed, placed next to sharp objects, or near a heat source.
15. Check power cords before using. Damaged cords can reduce performance of pressure washer or cause a fatal electrical shock.

16. *The narrow pin point stream is very powerful. It is not recommended for use on painted surfaces, wood surfaces, or items attached with an adhesive backing.*
17. *Keep operating area clear of all persons and animals.*
18. *Always use both hands when operating pressure washer to maintain complete control of the wand.*
19. *Do not touch nozzle or water spray while operating. Never place hands in front of nozzle.*
20. *Wear safety goggles while operating. Wear protective clothing and footwear to protect against accidental spraying.*
21. *Disconnect power plug from the outlet when not in use, and prior to the detaching of the high pressure hose.*
22. *Never tie knots or kink the high-pressure hose as damage could result. Inspect the high-pressure hose regularly. Replace the hose immediately if it is damaged, worn or shows any signs of cracks, bubbles, pinholes, or other leakage. Never grasp a high-pressure hose that is leaking or damaged.*
23. *Do not operate or store this product in temperatures below 40 °F (4 °C). Freeze damage is not covered by the warranty.*
24. *Carefully observe all chemical instructions and warnings before using. Use only approved pressure washer cleaners. Do not use bleach, chlorine, or any cleaners containing acids. Always follow manufacturer's label recommendations for proper use of cleaners. Always protect eyes, skin and respiratory system from cleaners.*
25. *The pressure washer should not be used in areas where gas vapors may be present. An electric spark could cause an explosion or fire.*
26. *To minimize the amount of water getting into the pressure washer, the unit should be placed as far as possible from the cleaning site during operation.*
27. *To prevent accidental discharge, the spray gun should be secured by locking the trigger when not in use.*
28. *To allow free air circulation, the pressure washer should not be covered during operation.*
29. *Never touch, grasp, or attempt to cover a pinhole or similar sized water leak on the high-pressure hose. The stream of water is under high pressure and will penetrate skin.*
30. *Use only hoses and accessories rated for pressure higher than your pressure washer's psi. Never use with any other manufacturer's accessories or components.*
31. *Never defeat the safety features of this product.*
32. *Do not operate machine with missing, broken, or unauthorized parts.*
33. *Never spray flammable liquids or use pressure washer in areas containing combustible dust, liquid, or vapors.*

▲WARNING: *Risk of injection or injury. Do not direct discharge stream at persons.*

SAVE THESE INSTRUCTIONS FOR FUTURE USE

GROUND INSTRUCTIONS

This product must be grounded. If it should malfunction or breakdown, grounding provides a path of least resistance for electric current to reduce the risk of electric shock. This product is equipped with a cord having an equipment-grounding conductor and a grounding plug. The plug must be plugged into an appropriate outlet that is properly installed and grounded in accordance with all local codes and ordinances.

▲ WARNING: *Improper connection of the equipment-grounding conductor can result in a risk of electrocution. Check with a qualified electrician or service person if you are in doubt as to whether the outlet is properly grounded. Do not modify the plug provided with the product if it will not fit the outlet installed by a qualified electrician. Do not use any type of adapter with this product.*

Power Supply And Electrical Info

GROUND-FAULT CIRCUIT INTERRUPTER PROTECTION

The pressure washer is factory-equipped with an electrical cord and a Ground Fault Circuit Interrupter (GFCI) power plug. This device provides additional protection from the risk of electric shock. This cord should only be connected to an electrical outlet installed in accordance with local safety regulations. Should replacement of the plug or cord become necessary, use only identical replacement parts that include GFCI protection.

NOTE: The power supply must be 120 V, 60 Hz, and a minimum 13.5 amp dedicated electrical circuit.

- A. Inspect cord before using. Do not use if cord is damaged.
- B. Keep all connections dry and off the ground.
- C. Do not touch plug with wet hands.
- D. The pressure washer is provided with a ground fault circuit interrupter built into the power plug.

If replacement of the plug or cord is needed, use only identical replacement parts. Contact customer service for proper replacement parts.

▲ WARNING: *Test GFCI before each use. DO NOT use pressure washer if test below fails.*

GFCI Test Procedures:

1. Plug GFCI into power receptacle. Indicator light should illuminate.
2. Press test button (X). Light should turn off.
3. Press reset button (Q) for use. Indicator light should illuminate. Do not use if above test fails.



NOTE: The GFCI must be reset each time the pressure washer is connected to an electrical outlet. Reset by simply pushing the reset button on the GFCI power plug.

DO NOT USE AN EXTENSION CORD WHILE OPERATING THE PRESSURE WASHER.

▲ WARNING: *To reduce the risk of electrocution, keep all connections dry and off the ground. Do not touch plug with wet hands.*

SAVE THESE INSTRUCTIONS FOR FUTURE USE

ASSEMBLY

Sanitizing Mister and Pressure Washing System

1. Slide the handle assembly (H) onto frame (F). Align handle assembly holes with frame holes. Insert saddle bolts (R) and secure with knobs (R). Tighten until snug.

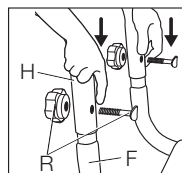

▲ CAUTION: Risk of personal injury. Avoid placing hands between handle and frame when assembling to prevent pinching.

2. For mister mode, attach high-pressure hose (G) to mister gun (C). Make sure connection is secure.
3. For pressure washer mode attach high-pressure hose (G) to spray gun (I). Make sure connection is secure.
4. Connect wand (E) to spray gun (I). Make sure connection is secure.
5. Remove the four colored quick-connect high pressure nozzles from the plastic bag and insert them into correct grommet on the nozzle holder. Nozzles are color coded to match colored nozzles on panel assembly.

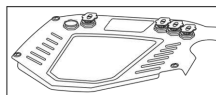

NOTE: The high-pressure pump was filled with oil at the factory. Always check oil level before using (refer to **Maintenance** for more information).

OPERATION





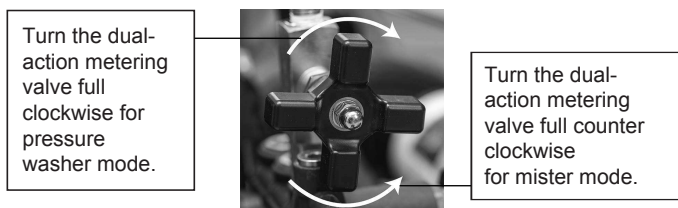



Selecting misting and pressure washing modes

Adjusting the dual-action metering valve will allow you to switch between misting and pressure washing modes (see illustration below).



Spray Wand Nozzles

The nozzles for the spray wand are stored in nozzle holders (B) on the panel assembly (A). Colors on the panel identify nozzle location and spray pattern. Refer to the following chart to choose the correct nozzle for the job to be performed.

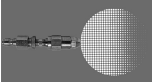
Nozzle Color	Spray Pattern	Uses	Surfaces*
Yellow 	15° 	intense cleaning of unpainted hard surfaces	grills, driveways, concrete or brick walkways, unpainted brick or stucco
Green 	25° 	standard cleaning nozzle for most applications	yard tools, sidewalks, lawn furniture, unpainted siding, stucco, gutters and eaves, concrete, brick surfaces
White 	40° 	cleaning of painted or delicate surfaces	auto/RV, marine, wood, painted brick and stucco, vinyl, painted siding
Soap 	low pressure 	applies soap	low pressure spray is safe on all surfaces. always verify compatibility of cleaning solution prior to use
Mister 	mist 	applies cleaning solutions via mist	misting spray is safe on all surfaces. always verify compatibility of cleaning solution prior to use

*** NOTICE:** *The high-pressure spray from your pressure washer is capable of causing damage to surfaces such as wood, glass, automobile paint, auto stripping and trim, delicate objects such as flowers and shrubs. Before spraying, check the item to be cleaned to assure yourself that it is strong enough to resist damage from the force of the spray.*

CHANGING NOZZLES AND SPRAY WAND

▲ DANGER: Risk of fluid injection. Do not direct discharge stream toward persons, unprotected skin, eyes or any pets or animals. Serious injury will occur.

▲ WARNING: Flying object could cause risk of serious injury. Ensure nozzle is completely inserted in quick-connect socket and quick-connect collar is fully engaged (forward) before squeezing gun trigger.

1. Pull quick-connect coupler back and insert nozzle.
2. Release quick-connect coupler and twist nozzle to make sure it is secure in coupler.

▲WARNING: Flying object could cause risk of serious injury. Ensure nozzle is completely inserted in quick-connect socket and quick-connect collar is fully engaged (forward) before squeezing gun trigger.

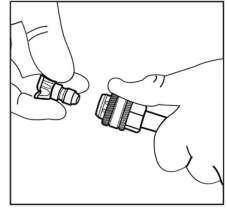

Starting

▲WARNING: To reduce the risk of injury, read the **sanitizing mister and pressure washer system instruction manual** before starting pressure washer.

▲DANGER: Risk of fluid injection and laceration. When using the high-pressure setting, **DO NOT** allow the high-pressure spray to come in contact with unprotected skin, eyes, or with any pets or animals. Serious injury will occur.

- Your washer operates at fluid pressures and velocities high enough to penetrate human and animal flesh, which could result in amputation or other serious injury. Leaks cause by loose fittings or worn or damaged hoses can result in injection injuries. **DO NOT TREAT FLUID INJECTION AS A SIMPLE CUT!** See a physician immediately!

NOTICE: NEVER pull water supply hose to move pressure washer. This could damage hose and/or pump inlet.

- DO NOT use hot water, use cold water only.
- Never turn water supply off while pressure washer motor is running or damage to pump will result.
- DO NOT stop spraying water for more than two minutes at a time. Pump operates in bypass mode when spray gun trigger is not pressed. When the temperature inside the pump rises too high, the thermal relief valve (T), will open and release a gush of water in an effort to lower the temperature inside the pump. The thermal relief valve will then close. If pumps is left in bypass mode for more than two minutes, internal components of the pump can be damaged.

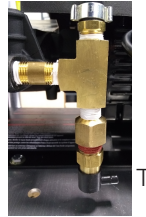

▲WARNING: Do not allow the unit to run for more than two minutes without the spray gun trigger being pulled. This could cause overheating and damage to the pump. When temperature inside the pump rises too high, the thermal relief valve will open and release a spray of water from the pump to lower the internal temperature. The valve will then close.

PRESSURE WASHER START UP

1. Connect the garden hose to the cold water source. Turn the water source on to remove all air from the hose. When a steady stream of water is present, turn the water source off.
2. Verify the filter screen (U) is in water inlet of pump. Convex side faces out.
3. Connect the cold water source (V) to pump inlet.

NOTE: If using in pressure washer mode, water source must provide a minimum of 5 gallons per minute at 20 psi (138 kPa).

▲WARNING: To reduce the possibility of contamination, always protect against back-flow when connected to a potable water system.

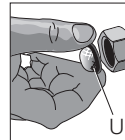

4. Connect high-pressure hose (G) to pump outlet.
5. **Do not use bleach.** For more information on using chemicals or cleaning solutions, refer to **Chemicals and Cleaning Solvents Section.**

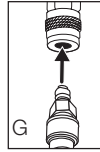

6. Turn the water source on.
7. Plug GFCI (W) into power receptacle. Firmly press the TEST button (X), then press and release the RESET button (Q). The light on the GFCI should be illuminated.

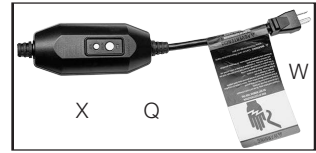

8. Place the motor ON/OFF switch (L) to the ON position.
9. Remove all air from the pump and high-pressure hose by letting pump run until air is no longer present in discharge from hose.

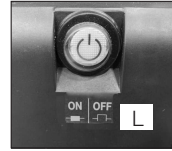

10. For pressure washing, attach high-pressure hose (G) to spray gun (I). Make sure it is secure.

▲WARNING: Risk of unsafe operation. Stand on stable surface and grip gun/wand firmly with both hands. Expect the gun to kickback when triggered.



11. Squeeze trigger on spray gun to start flow.
12. Release trigger on spray gun to stop flow.

▲DANGER: Risk of injury from spray. Engage the trigger lock (X) when gun is not in use to prevent accidental spraying.

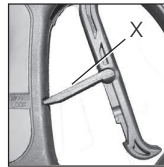

13. Adjust spray for the task being performed by changing quick connect nozzle. Refer to **Spray Wand Nozzles.**

MISTER START UP

1. Place filter end of supply and relief hoses into a chemical container (1).
2. Connect threaded end of supply hose (V) to pump inlet.
3. Connect the high-pressure hose (G) to pump outlet.

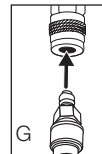
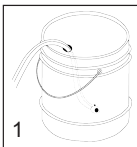

4. Attach high-pressure hose (G) to mister spray gun (C). Make sure connection is secure.

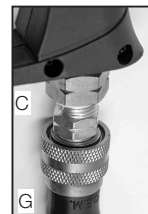

5. Plug GFCI (W) into power receptacle. Firmly press the TEST button (X), then press and release the RESET button (Q).

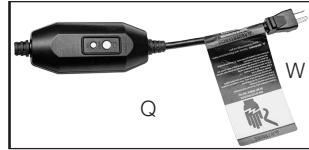

6. The light on the GFCI should be illuminated. Place the motor ON/OFF switch (L) to the ON position.

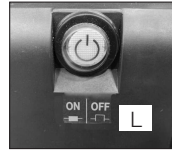

7. Remove all air from the system by squeezing mister spray gun trigger until air is no longer present in discharge.

8. Squeeze the mister spray gun to apply mist in an even sweeping motion at approximately one foot per second.

9. Release trigger on spray gun to stop flow.

NOTE: Refer to disinfectant manufacturers instructions for how long surfaces need to remain wet.

▲ DANGER: Risk of injury from spray. Engage the trigger lock (X) when gun is not in use to prevent accidental spraying.

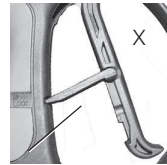

Misting with Chemicals and Cleaning Solvents

Applying chemicals or cleaning solvents is a low-pressure operation.

NOTE: For disinfecting mister use, Simpson recommends Vital Oxide. Always refer to the chemical manufacturers Material Data Safety Sheet to see if chemical is safe for misting before use. Use only soaps and chemicals designed for pressure washer use. **Do not use bleach.**

TO APPLY CHEMICALS IN MISTING MODE

1. Place filter end of supply and relief hoses into a container of approved chemical.
2. Connect threaded end of supply hose to pump inlet.
3. Connect relief hose to thermal relief valve (3).
4. Connect the high-pressure hose to pump outlet.
5. Refer to the **MISTER START UP** section to begin misting.

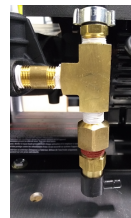

APPLICATION OF MIST

For disinfecting pre-cleaned, hard, non-porous surfaces, follow these instructions.

1. Remove dirt, grime, or organic matter by cleaning before surface before mist application.
2. With the gun trigger squeezed, apply mist in an even sweeping motion at approximately one foot per second.

3. For virus inactivations, allow surfaces to remain wet for five to ten minutes. Allow surfaces to remain wet for ten minutes for bacterial disinfection.

NOTE: Refer to disinfectant manufacturers instructions for how long surfaces need to remain wet.

TO APPLY CHEMICALS AND SOLVENTS IN PRESSURE WASHER MODE

1. Press chemical hose (S) onto barbed fitting located near high-pressure hose connection of pump as shown.
2. Place the other end of chemical hose with filter on it into the container holding chemical/cleaning solution.

NOTE: For every 10 gallons (38 liters) of water pumped 1 gallon (3.8 liters) of chemical/cleaning solution will be used.

3. Install low-pressure (soap) nozzle into quick connect fitting of spray wand. refer to **Spray Wand Nozzles**.

NOTE: Chemicals and soaps will not siphon if the black soap nozzle is not installed on the spray wand.

4. After use of chemicals, place chemical hose into container of clean water and draw clean water through chemical injection system to rinse system thoroughly. If chemicals remain in the pump it could be damaged. Pumps damaged due to chemicals will not be covered under warranty.

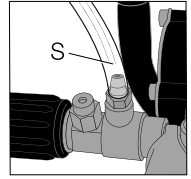

Shutting Down

1. If chemicals were applied, disconnect the spray gun, and place the high-pressure hose into a container of clean water. Cycle clean water through the pump to rinse system thoroughly.
2. After pump has been cleaned, connect gun to high-pressure hose, and cycle clean water through the gun until clean.

NOTICE: Risk of property damage. Failure to do so could cause damage to the pump.

3. Place the motor ON/OFF switch (L) to the OFF position.

NOTICE: Risk of property damage. NEVER turn water supply off while pressure washer is running or damage to pump will result.

4. Turn water source off.
5. Pull trigger on spray gun to relieve any water pressure in hose or spray gun.
6. Remove both the garden hose and high-pressure hose from the unit.
7. Disconnect the wand from the gun.
8. Turn ON the machine and allow it to run for 5 seconds. (This will clear out most of the water trapped in the pump). Then turn OFF the machine.
9. Unplug machine
10. Refer to **STORAGE** for proper storage procedures.

MAINTENANCE

⚠ WARNING: Risk of burning. When performing maintenance, you may be exposed to hot surfaces, water pressure or moving parts that can cause serious injury or death.

To ensure efficient operation and longer life of your pressure washer, a routine maintenance schedule should be prepared and followed. If the pressure washer is used in unusual conditions, such as high temperatures or dusty conditions, more frequent maintenance checks will be required.

Pump

NOTE: The pump was filled with oil at the factory. The preferred oil is

SIMPSON® Premium Pump Crankcase Oil. If this oil is not available, an SAE 15W-40 oil may be used. Change the pump oil after the first 50 hours of operation and every 100 hours thereafter, or every 3 months. Oil capacity is 11.2 oz. (0.33 liters). Oil should be changed at least once a year.

TO CHECK OIL

The oil level should come to the dot in the middle of the sight glass (AA).

How to change high-pressure pump oil:

1. Loosen pump oil fill plug (BB).
2. Place a container under the oil drain plug (CC).
3. Remove pump oil drain plug at the base of the pump (CC).
4. After oil is drained, replace oil drain plug. Tighten securely.
5. Remove pump oil fill plug and fill with pump oil.
6. Replace pump oil fill plug and tighten securely.

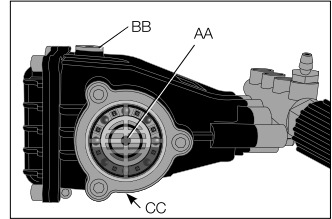

Nozzle Cleaning (non-misting nozzles)

If the nozzle becomes clogged with foreign materials, such as dirt, excessive pressure may develop. If the nozzle becomes partially clogged or restricted, the pump pressure will pulsate. Clean the nozzle immediately using the nozzle kit supplied and the following instructions.

1. Shut off the pressure washer and turn off the water supply.
2. Pull trigger on gun handle to relieve any water pressure.
3. Disconnect the spray wand from the gun. Remove the high-pressure nozzle from the spray wand.
4. Remove any obstructions with the nozzle cleaning tool (Y) provided and back flush with clean water.
5. Direct water supply into spray nozzle to back flush loosened particles for 30 seconds.
6. Reassemble the nozzle to the wand.
7. Reassemble spray wand to gun, then turn on water supply.

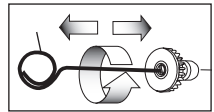

To Clean the Water Inlet Filter

This filter screen (U) should be checked periodically and cleaned if necessary.

1. Remove the filter screen (U) by grasping the end and removing it from water inlet of pump.
2. Clean filter by flushing it with water on both sides.
3. Reinsert filter into water inlet of pump. Convex side faces out.

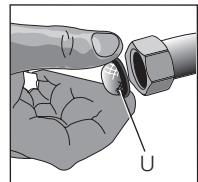

NOTE: Do not operate pressure washer without filter properly installed.

STORAGE

Pump

The manufacturer recommends using SIMPSON® / POWERWASHER™* Pump Guard or equivalent when storing the unit for more than 30 days and/or when freezing temperatures are expected. SIMPSON® / POWERWASHER™ Pump Guard is environmentally friendly.

NOTE: Using pump guard helps provide proper lubrication to the internal seals of the pump regardless of temperature or environment.

NOTICE: *Risk of property damaged. Use only SIMPSON® / POWERWASHER™ Pump Guard or equivalent. Other products could be corrosive and/or contain alcohol which may cause pump damage.*

1. Turn off pressure washer and disconnect hoses from pump.
2. Unscrew bottle valve from Pump Guard bottle and remove seal.
3. Screw bottle valve back onto bottle.
4. Attach bottle to water inlet of pump.
5. Squeeze bottle to inject contents into pump.

Pressure Washer

1. Drain all water from high-pressure hose, coil it and store it in cradle of the pressure washer handle.
2. With nozzle pointed down and the spray gun and wand in a vertical position. squeeze trigger to drain all water from spray gun and wand. Store in gun holder.
3. Store chemical hose so it is protected from damage.
4. Store the machine and accessories in a dry, climate controlled environment. Do not store the machine or accessories in a place where the temperature could drop below 40 °F (4 °C).

NOTICE: *Risk of property damage. Always store and transport unit in an upright position.*

ACCESSORIES

Recommended accessories for use with your tool are available for purchase from your local dealer or authorized service center. If you need assistance in locating any accessory for your tool, please contact FNA GROUP at www.simpsoncleaning.com, 7152 99th Street, Pleasant Prairie, WI 53158 or call 1 (877) 362 4271.

▲ DANGER: *Risk of fluid injection. When using replacement lances or guns with this pressure washer, DO NOT use a lance and/or lance/gun combination that is shorter in length than what was provided with this pressure washer as a measured from the nozzle end of the lance to the gun trigger.*

▲ WARNING: *The use of any other accessory not recommended for use with this tool could be hazardous. Use only accessories rated equal to or higher than the rating of the pressure washer.*

SERVICE INFORMATION

Please have the following information available for all service calls:

Model Number _____ Serial Number _____

Date and Place of Purchase _____

Repairs

To assure product SAFETY and RELIABILITY, repairs, maintenance and adjustment should be performed by a FNA factory service center, a FNA authorized service center or other qualified service personnel. Always use identical replacement parts.

Limited Warranty

- The manufacturer of this product agrees to repair or replace designated parts that prove defective within the warranty period listed below at the manufacturer's sole discretion. Specific limitations/extensions and exclusions apply.
- This warranty covers defects in material and workmanship and not parts failure due to normal wear, depreciation, abuse accidental damage, negligence, improper use, maintenance, or storage. To make a claim under the terms of the warranty, all parts said to be defective must be retained and available for return upon request to a designated Warranty Service Center for warranty inspection. The judgments and decisions of the manufacturer concerning the validity of warranty claims are final.
- These warranties pass through to the end user and are non-transferable. As a factory authorized and trained Warranty Service Center, the factory will honor the terms of all component warranties and satisfy claims of the appropriate warranty provisions. Normal wear items include, but are not limited to, valves and seals, which are not covered by this warranty.
- This warranty replaces all other warranties, express or implied, including without limitation any warranties of merchantability or fitness for a particular purpose and all such warranties are hereby disclaimed and excluded by the manufacturer. The manufacturer's warranty obligation is limited to repair and replacement of defective products as provided herein and the manufacturer shall not be liable for any further loss, damages, or expenses - including damages from shipping, accident, abuse, acts of God, misuse, or neglect. Neither is damage from repairs using parts not purchased from the manufacturer or alterations performed by non-factory authorized personnel. Failure to install and operate equipment according to the guidelines put for in the instruction manual shall void warranty.

This warranty does not cover the following: machines used for rental purposes, damage resulting from shipping (claims must be filed with freighted), accident, abuse, act of God, misuse, or neglect. Neither is damage from repairs or alterations performed by non-factory authorized personnel or failure to install and operate equipment according to the guidelines put forth in the instruction manual. The manufacturer will not be liable to any persons for consequential damage, for personal injury, or for commercial loss.

WARRANTY DOES NOT APPLY TO FAILURES DUE TO:

- Freight damage
- Freeze damage
- Damage caused by parts or accessories not obtained from an authorized dealer or not approved by the manufacturer.
- Normal wear of moving parts or components affected by moving parts.

HIGH-PRESSURE PUMP (DEFECTS IN MATERIAL AND WORKMANSHIP)

Five (5) years from date of purchase.

SELF-PRIMING SUPPLY PUMP (DEFECTS IN MATERIAL AND WORKMANSHIP)

Four (4) years consult pump manufacturer's literature for more warranty information.

FRAME (DEFECTS IN MATERIAL AND WORKMANSHIP)

Five (5) years from date of purchase.

MOTOR (DEFECTS IN MATERIAL AND WORKMANSHIP)

One (1) year from date of purchase.

ACCESSORIES (DEFECTS IN MATERIAL AND WORKMANSHIP)

Includes nozzles, hoses, spray guns, wands ninety (90) days from date of purchase.

Glossary

Bypass mode: Allows water to re-circulate within pump when the gun trigger is not pulled.

Chemical hose: Feeds cleaning agents into the pump to mix with water. Refer to **Chemicals and Cleaning Solvents**.

Chemical injection system: Mixes cleaners or cleaning solvents with water to improve cleaning effectiveness.

CU: Cleaning Units. GPM multiplied by PSI. (GPM x PSI = CU)

Disinfecting: Refers to using chemicals to kill germs on surfaces or objects. This process does not necessarily clean dirty surfaces or remove germs, but by killing germs on a surface after cleaning, it can further lower risk of spreading infection. Removing or deactivating unwanted microorganisms down to 6 log reductions (99-99.9999%).

GPM: Gallons Per Minute. The unit of measure for the flow rate of water.

PSI: Pounds per Square Inch. The unit of measure for water pressure. Also used for air pressure, hydraulic pressure, etc.

kPa (kilopascal): Metric pressure measurement. 1 kilopascal equals 1000 pascals. **Quick-connect spray wand:** Allows the user to quickly change out high-pressure nozzles. Refer to **Spray Wand Nozzles**.

Thermal Relief Valve: When the temperature inside the pump rises too high the valve will open and release a gush of water in an effort to lower the temperature inside the pump. The valve will then close.

Water supply: All pressure washers must have a source of water. The minimum requirements for a water supply are 20 psi (138 kPa) and 5 gallons per minute.

TROUBLESHOOTING GUIDE

This section provides a list of the more frequently encountered malfunctions, their causes and corrective actions. The operator or maintenance personnel can perform some corrective actions, and other may require the assistance of a qualified FNA technician or your dealer.

Problem	Code
Motor will not start when switched ON.....	1, 11
When unit is switched ON, the motor hums but does not turn	2, 3
The motor stops	4
No or low pressure (initial use)	5, 6, 7, 8, 9, 10, 12
Will not draw chemicals	12, 13, 14, 15, 16, 17
No or low pressure (after period of normal use)	18, 19, 20
Water leaking at gun/spray wand connection	21, 22



Problem**Code**

Water leaking at pump	21, 22, 23, 24
Oil leaking at pump	25, 26, 27, 28, 29, 30, 31
Pump Pulsates.....	8

TROUBLESHOOTING GUIDE

CODE	POSSIBLE CAUSE	POSSIBLE SOLUTION
1	ON/OFF switch in OFF position.	Place ON/OFF switch in ON position.
2	The main voltage is insufficient, lower than the minimum required.	Check that the main power supply is adequate.
3	Extension cord is too long or wire gauge is too small.	We do not recommend the use of extension cords with your pressure washer.
5	Spray wand not in high pressure.	See Spray Wand Nozzle under Operation .
6	Low water supply.	Water supply must be at least 5 GPM @ 20 psi (138 kPa).
7	Leak at high-pressure hose fitting.	Repair O-ring.
8	Nozzle obstructed.	See Nozzle Cleaning under Maintenance .
9	Water filter screen clogged.	Remove and clean filter.
10	Air in hose.	Turn off the engine, then the water source. Disconnect the water source from the pump inlet and turn the water source on to remove all air from the hose. When there is a steady stream of water present, turn water source off. Reconnect water source to pump inlet and turn on water source. Squeeze trigger to remove remaining air.
11	GFCI Plug is not reset	Confirm the GFCI plug is reset and functioning according to instructions provided in Ground-Fault Circuit Interrupter Protection paragraph under <i>Power Supply & Electrical</i> info in this manual.
12	High-pressure hose is too long.	Use high-pressure hose under 100 feet (30.48 m). Lengthen water supply hose instead of high-pressure hose.
13	Spray wand not in low pressure.	See Spray Wand Nozzles under Operation .
14	Chemical filter clogged.	Clean filter.
15	Chemical screen not in cleaning solution.	Make sure end of chemical hose is fully submerged into cleaning solution.

CODE	POSSIBLE CAUSE	POSSIBLE SOLUTION
16	Chemical too thick.	Dilute chemical. Chemical should be the same consistency as water.
17	Worn seal or packing.	Have parts cleaned or replaced by an authorized service center.
18	Chemical build up in chemical injector.	Have replaced by an authorized service center.
19	Worn or obstructed valves.	Have replaced by an authorized service center.
20	Worn unloader piston.	Have replaced by an authorized service center.
21	Worn or broken o-ring.	Check and replace.
22	Loose hose connection.	Tighten.
23	Piston packings worn.	Have replaced by an authorized service center.
24	Pump head or tubes damaged from freezing.	Have replaced by an authorized service center.
25	Oil seals worn.	Have replaced by an authorized service center.
26	Loose drain plug.	Tighten.
27	Worn drain plug o-ring.	Check and replace.
28	Worn oil fill plug o-ring.	Check and replace.
29	Pump overfilled.	Check for correct amount.
30	Incorrect oil used.	Drain and fill with correct amount and type of oil.
31	Oil vent plug is clogged.	Clean vent plug; blow air through it to remove any blockage. If problem persists, replace plug.

QUICK SETUP GUIDE



WARNING: To reduce the risk of injury, read the pressure washer instruction manual before operating pressure washer.

1 Install the Handle

Slide the handle assembly (H) onto the frame (F). Align handle assembly holes with frame holes. Insert saddle bolts (R) and secure in place with knobs (R). Tighten until snug.

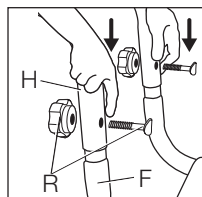

2 Install the Nozzles

Remove the four colored quick-connect high-pressure nozzles from the plastic bag, and insert them into correct grommet nozzle holder. Nozzles are color coded to match colored nozzles on panel assembly.

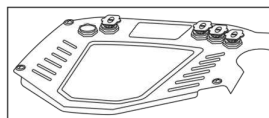

3 Assemble Spray Gun and Wand

Connect wand (E) to spray gun (I). Make sure connection is secure.

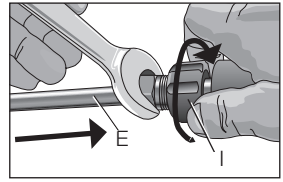

NOTE: Always check high-pressure pump oil level before using. Add as required.

QUICK SETUP GUIDE

DANGER: Risk of fluid injection and laceration. When using the high-pressure setting, DO NOT allow the high-pressure spray to come in contact with unprotected skin, eyes or with any pets or animals. Serious injury will occur.

WARNING: To reduce risk of electrocution, keep all connections dry and off the ground. Do not touch plug with wet hands.

WARNING: DO NOT allow the unit to run for more than two minutes without the spray gun trigger being pulled. This could cause overheating and damage to the pump. When the temperature inside the pump rises too high, the thermal relief valve will open and release a spray of water from the pump to lower the internal temperature. The valve will then close.

1 Connect Water Hose to Water Source.

Turn the water source on to remove all air from the hose. When a steady stream of water is present, turn the water source off.

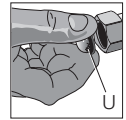

2 Check Pump Filter Screen

Verify the filter screen (U) is in water inlet of pump. Convex side faces out.

3 Connect Pickup Tube or Water Source to Pump

If using supply and relief hoses for mister, place the filter end into disinfectant (3), connect threaded end of supply hose (V) to pump inlet, and connect the other end of the relief hose to the thermal relief valve.

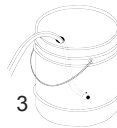

NOTE: If using in pressure washer mode, water source must provide a minimum of 5 gallons per minute at 20 psi (138 kPa).

4 Connect High-Pressure Hose to Pump

Connect the high-pressure hose (G) to pump outlet.

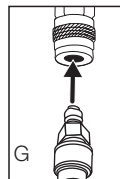

5 Connect Mister or Spray Gun

For mister mode, attach high pressure hose (G) to mister spray gun (C). For pressure washer mode, attach high-pressure hose (G) to spray gun (I). Make sure connection is secure.

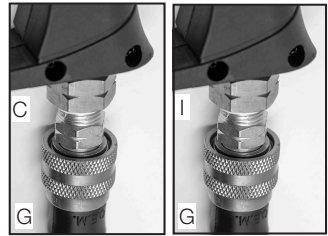

6 Turn Water Faucet Completely On

If using water faucet as source, turn the faucet completely on. Do not run the unit without cold water supply connected and turned on. Use cold water only.

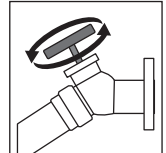

7 Connecting and testing GFCI.

Plug GFCI (W) into power receptacle. Firmly press the TEST button (X), then press and release the RESET button (Q). The light on the GFCI should be illuminated.

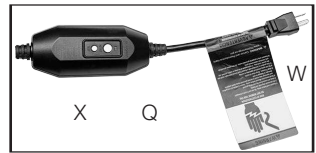

8 Turn the Mister/Pressure Washer On

Place the motor ON/OFF switch (L) to the ON position. Switch will light green.



9 Release Air From System

Remove all air from the pump and high-pressure hose by squeezing gun trigger until air is no longer present in discharge from gun.

10 Connect QC Nozzles to Spray Wand

Pull quick connect coupler back and insert nozzle. Release quick connect coupler and twist nozzle to make sure it is secure in coupler.

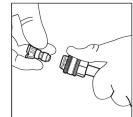

11 Changing from Mister to Pressure Washer

For light mist, adjust the dual-action metering valve (N) counterclockwise. For pressure washer mode, turn the dual-action metering valve (N) fully clockwise.

Turn full clockwise for pressure washer mode

Turn full counterclockwise for mister mode

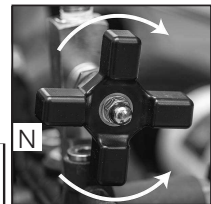

12 Mister & Pressure Washer Operation

Squeeze trigger on gun to start flow. Release trigger to stop flow.

⚠ DANGER: Risk of injury from spray. Engage trigger lock (X) when gun is not in use to prevent accidental spraying.

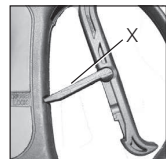

⚠ WARNING: This guide is not a substitute for reading the operator's manual. User must read and understand operator's manual before using this product.



SIMPSON

Internet Address: www.simpsoncleaning.com
Warranty Registration via Internet

Adresse Internet : www.simpsoncleaning.com
Enregistrement de la garantie par Internet

Sitio Address: www.simpsoncleaning.com
Registro Garantía mediante Internet

Copyright. All Rights Reserved

Copyright. Todos los derechos reservados

Copyright. Tous droits réservés

FNA Group, Inc.
7152 99th Street
Pleasant Prairie, WI 53158

Assembled in U.S.A with domestic and foreign components
Assemblé aux États-Unis avec des composants nationaux et étrangers
Ensamblado en los EE.UU. utilizando componentes domésticos e importados