



AQ-CWM2-B

Countertop Water Filter

Clean Water Machine

Owner's Manual





Meet clean, healthy water. Your new Clean Water Machine features Claryum® filtration that removes up to 99% of 78 contaminants including lead, PFOA/ PFOS, pesticides, pharmaceuticals, and chlorine*.

Enjoy the peace of mind that comes from knowing our award-winning filter technology is working for you.

AQ-CWM2-B

Countertop Water Filter

Clean Water Machine

TABLE OF CONTENTS

Box Contents	1
Use & Care	2
Setup	3-4
Operation.....	5
Troubleshooting Guide, Button Functions, & Light Indicators	6
Filter Replacement	7
Performance & Certifications	8
Warranty	9
Water for Life® Program.....	Back

**See Performance & Certifications (page 8) for specifics about contaminants removed.*

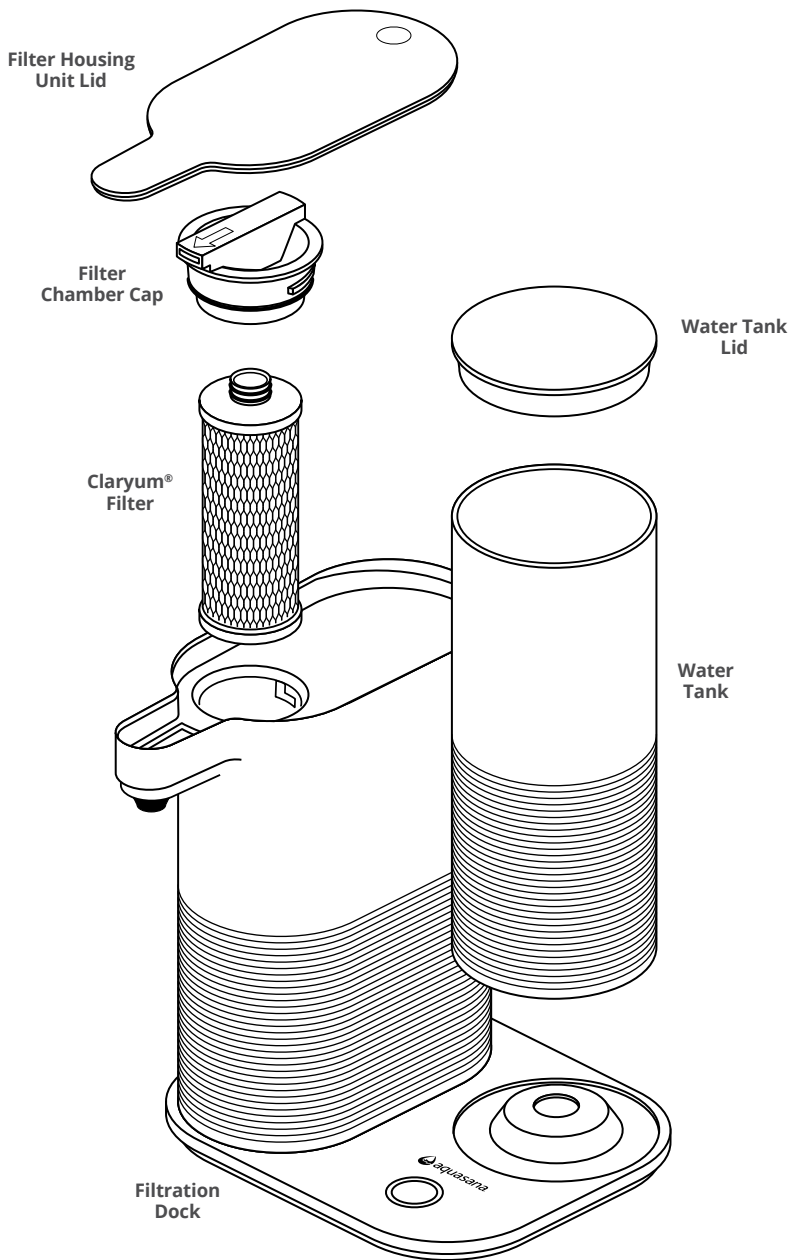
No tools required for installation!

Before beginning setup, please ensure all parts listed are present. If any part is missing or damaged, please contact Customer Support at **866-662-6885**.

Please read all precautions and instructions carefully before using.

Use and Care

- To clean the system, wipe exterior with a damp cloth. Do not use any strong or abrasive cleaning agent or solvent cleaner.
- The water tank, housing lids, and filter cap are NOT dishwasher safe, and should be hand-washed only.
- Water may accumulate inside the filter housing unit. Dry this area with a clean dry cloth.
- Clean regularly for best use.

Scan to view the Clean Water Machine product and installation video.

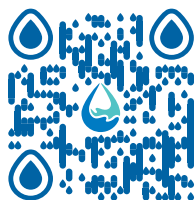

Important Safeguards

- Do not operate without filter cartridge installed.
- Use only cold tap water in the water tank. Do not add ice cubes to water tank.
- Do not place cord, plug, or system in water or other liquids.
- Close supervision is always necessary when this system is used by or near children.
- Intended for home or office use, on a flat, temperature-controlled surface. Not for outdoor use.
- Do not place the system near a hot gas or electric burner.
- Do not let cord hang over the edge of table or countertop, or touch hot surfaces. Do not allow anything to rest on the power cord.
- If the supply cord or the plug are damaged, do not use and contact Customer Service.
- Do not use excessive force on the dock button.
- Filter usage must comply with all state and local laws.
- Do not use with water that is microbiologically unsafe or of unknown water quality without adequate disinfection before or after the system.
- Systems certified for cyst reduction may be used on disinfected waters that may contain filterable cysts.

① Wash Tank

At first use or after a long period of non-use

Hand-wash the water tank and water tank lid with dish soap and rinse well. Fill water tank full with cold tap water.

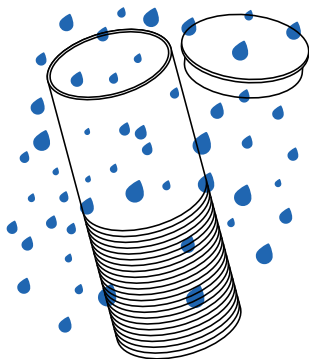

Place the water tank on the dispenser dock and ensure it's firmly attached to its base.

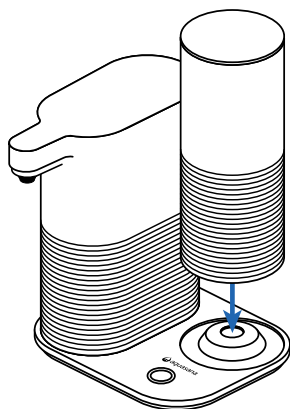

② Open Filter Chamber

Open filter housing unit lid and unscrew filter chamber cap to open the filter chamber.

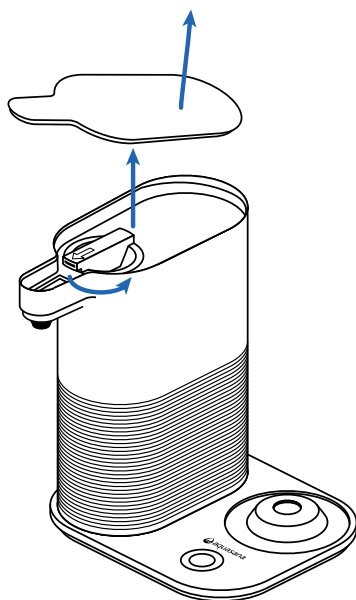

3 Insert Filter

Remove plastic from filter cartridge.

With top of filter up, press the filter onto the filter chamber cap.

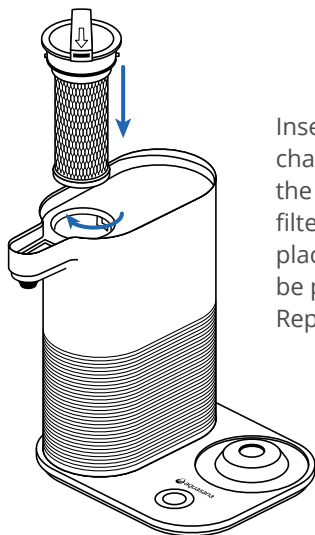
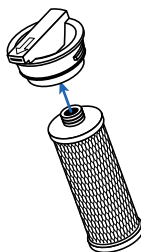

Insert the filter with the attached filter chamber cap onto the chamber so that the grooves of the cap line up. Twist the filter chamber cap to the right to lock into place. Arrow on filter chamber cap should be pointing towards the dispenser end. Replace the filter housing lid.

4 Flush System

Plug your system in. Place vessel (at least 64 oz.) underneath dispenser during flushing cycle.

To start the flush cycle, press dock button 3 times quickly. Light will illuminate red for 5 seconds.

While red light is illuminated, press and hold dock button for 1 second. Light will blink red. While system flushes, light will change from red to blue staying blue for 5 seconds when flush is complete.

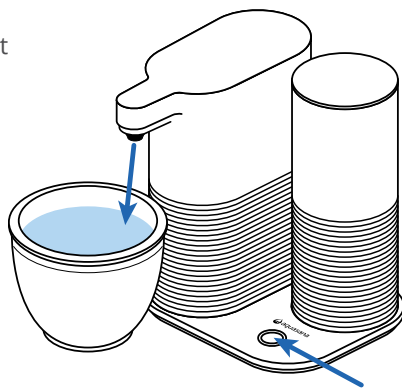

NOTE: Do not drink flushed water. Discard water.

Dispensing Water

First, fill the water tank and place it back onto the dispenser dock. Position vessel under dispenser.

Next, press and hold dock button to dispense filtered water. Light will illuminate blue while dispensing water.

Finally, release dock button once desired amount of water is reached.

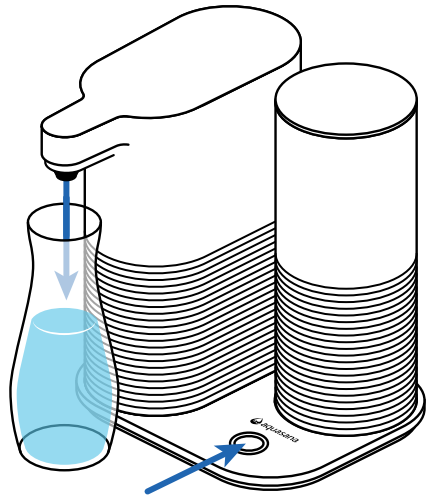
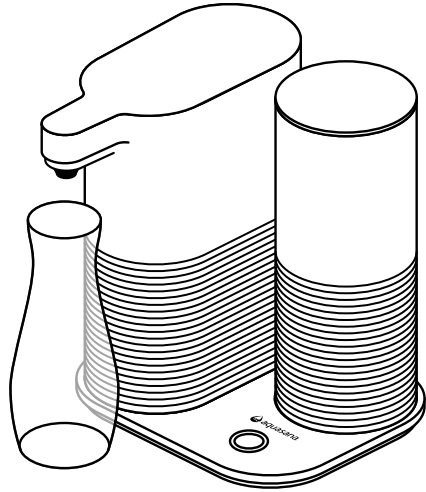

NOTE: When filling a larger (64 oz) vessel, you may use the Quick Press function. Quickly press the dock button once to initiate fill. Once desired amount is reached, quickly press dock button to stop dispensing.

NOTE: System will dispense water for a maximum of 60 seconds at one time. Timer will override system and shut off pump.

What should I do if my system won't run?

- Make sure the system is plugged into a power source.
- Ensure water tank is fully attached to filtration dock.
- Make sure water tank contains water. System will not run without water.
- Ensure filter and filter chamber lid are properly attached.
- Ensure dock button is being held for the proper amount of time.

What if water is leaking from the system?

- Ensure the water tank is fully attached to the filtration dock.

Why does my water look milky or cloudy?

- Cloudy or white water is a result of air bubbles that are trapped within the system. This is very common and not harmful. The air bubbles will dissipate over time.

Button Functions	
Function	Button Action
Quick Press On	Press button 1X
Quick Press Off	Press button 1X
Dispense water	Press and hold button until desired amount is dispensed
Stop dispensing water	Release button hold
Initiate filter flush process	Press button 3X rapidly
Start filter flush	Press and hold for 1 second

Light Indicators	
Light Status	Indication
No light	System unplugged, standby mode, or flush not initiated
Solid red/blue combination	Initial system plug in
Solid blue light when dispensing water	Dispensing filtered water
Blink blue	System is readying to dispense water
Solid red light (5 seconds)	Filter flush process initiated
Blinking red when system flushing	Flush in process
Blinking red to blue	Finishing flush
Blinking blue then solid blue	Filter flush complete
Alternating blue and red while dispensing water	Change filter soon
Solid red while dispensing water	Change filter now
Blinking red while in standby mode	Change filter now

1. Twist filter chamber cap to the left and remove dirty filter from cap. Discard dirty filter.

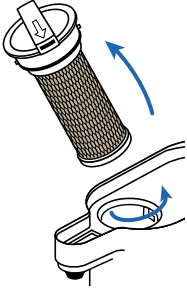

2. Remove plastic from clean filter. Press clean filter into filter chamber cap ensuring a snug fit. Insert into housing unit and twist right to close.

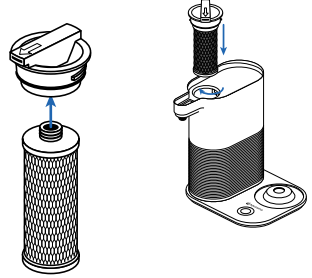

3. Fill water tank and place on dispenser dock.

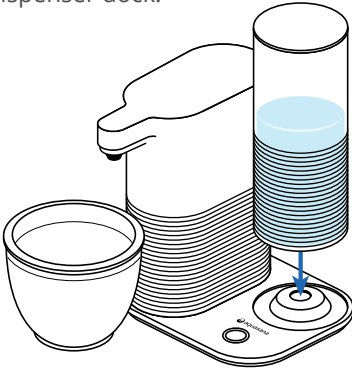

4. Press dock button 3 times quickly. Light will illuminate red for 5 seconds.

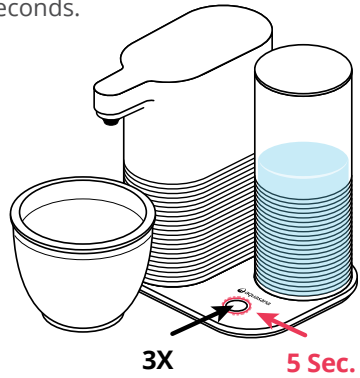

5. While red light is illuminated, press and hold dock button for 1 second. Light will blink red. While system flushes, light will change from red to blue staying blue for 5 seconds when flush is complete.

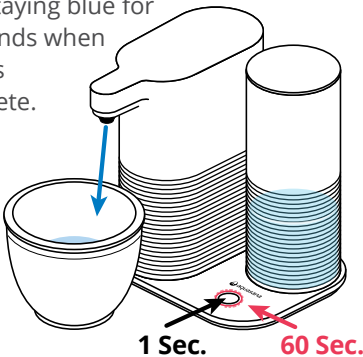

6. Once the flush is complete, light blinks blue for 5 seconds, then illuminate solid blue for 5 seconds.

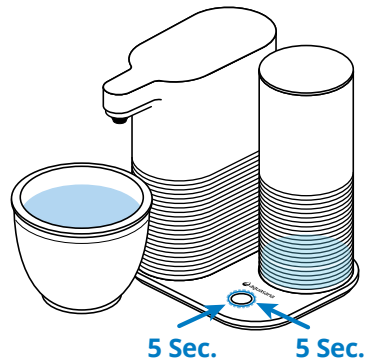

Model	Replacement	Rated Capacity	Operating Pressure Range	Operating Temp. Range	Rated Flow
AQ-CWM2-B AQ-CWM2-B-Q	AQ-CWM2-R AQ-CWM2-R-Q	300 gallons 1135 liters	20-70 psi 137-482 kPa	40-90° F 4.44-32.2° C	0.5 gpm 1.9 lpm
Manufactured by: AquaSana, Inc. 6310 Midway Road · Haltom City, Texas 76117 · 866.662.6885					

This system has been tested according to NSF/ANSI 42, 53, & 401 for reduction of the substances listed below. The concentration of the indicated substances in water entering the system was reduced to a concentration less than or equal to the permissible limit for water leaving the system, as specified in NSF/ANSI 42, 53, & 401.

NSF/ANSI 42	Minimum Reduction	Overall % Reduction	Results
Chlorine Reduction	≥50%	97.3%	Pass
Chloramine Reduction	0.5 mg/l	91%	Pass
Particulate Class I (particles 0.5 to <1 µm)	≥85%	99.6%	Pass

NSF/ANSI 53	Minimum Reduction	Overall % Reduction	Results
Asbestos Reduction	99%	>99%	Pass
Cyst (Microspheres)	99.95%	99.997%	Pass
Lead pH 6.5	5 ug/L	>99.7%	Pass
Lead pH 8.5	5 ug/L	99.6%	Pass
Mercury pH 6.5	2 ug/L	>96.2%	Pass
Mercury pH 8.5	2 ug/L	95.4%	Pass
MTBE Reduction	5 ug/L	85.5%	Pass
Perfluorooctanoic acid (PFOA) & Perfluorooctane sulfonate (PFOS)	0.02 ug/L	99.7%	Pass
Turbidity	0.5 NTU	99.34%	Pass
VOC Surrogate Test (as chloroform)	See Table 8.2	99.3%	Pass

NSF/ANSI 401	Maximum Concentration	Minimum Reduction	Overall % Reduction	Results
Atenolol	30 ng/L	94.7%	>94.7%	Pass
Bisphenol A	300 ng/L	93.2%	93.9%	Pass
Carbamazepine	200 ng/L	98.4%	>98.4%	Pass
DEET	200 ng/L	98.4%	>98.4%	Pass
Estrone	20 ng/L	94.8%	95.5%	Pass
Ibuprofen	60 ng/L	93.5%	94.6%	Pass
Linuron	20 ng/L	96.3%	>96.3%	Pass
Meprobamate	60 ng/L	94.6%	>94.6%	Pass
Metolachlor	200 ng/L	98.4%	>98.4%	Pass
Naproxen	20 ng/L	94.5%	95.5%	Pass
Nonyl phenol	200 ng/L	89.3%	95.5%	Pass
Phenytoin	30 ng/L	95.4%	>95.7%	Pass
TCEP	700 ng/L	98%	>98%	Pass
TCPP	700 ng/L	97.9%	>97.9%	Pass
Trimethoprim	20 ng/L	96.1%	>96.1%	Pass
Microplastics (particles 0.5 to <1 µm)	At least 10,000 particles/mL	≥85%	99.6%	Pass



System tested and certified by WQA to NSF/ANSI Standard 42, 53, and 401 for the reduction of the claims specified on the Performance Data Sheet and at WQA.org.

- All contaminants reduced by this filter are listed.
- Not all contaminants listed may be present in your water.
- Does not remove all contaminants that may be present in tap water.
- The contaminants covered in NSF/ANSI 401 have been deemed as incidental/emerging compounds and have been detected in drinking water supplies at trace levels. These compounds can affect some consumers' perception of drinking water quality.



Filter is only to be used with cold water.



Systems certified for cyst reduction may be used on disinfected waters that may contain filterable cysts.



Testing was performed under standard laboratory conditions, actual performance may vary.

Table 8.2 – Performance data sheet reduction claims for organic chemicals included by surrogate testing

VOCs (by surrogate testing using chloroform)	Drinking water regulatory level (MCL/MAC) mg/L	Influent/Unfiltered mg/L	Effluent/Filtered mg/L	Percent Reduction
alachlor	0.002	0.050	0.001	>98%
atrazine	0.003	0.100	0.003	>97%
benzene	0.005	0.081	0.001	>99%
carbofuran	0.04	0.190	0.001	>99%
carbon tetrachloride	0.005	0.078	0.0018	98%
chlorobenzene	0.1	0.077	0.001	>99%
chloropicrin	—	0.015	0.0002	99%
2,4-D	0.07	0.110	0.0017	98%
dibromochloropropane (DBCP)	0.0002	0.052	0.00002	>99%
o-dichlorobenzene	0.6	0.080	0.001	>99%
p-dichlorobenzene	0.075	0.040	0.001	>98%
1,2-dichloroethane	0.005	0.088	0.0048	95%
1,1-dichloroethylene	0.007	0.083	0.001	>99%
cis-1,2-dichloroethylene	0.07	0.170	0.0005	>99%
trans-1,2-dichloroethylene	0.1	0.086	0.001	>99%
1,2-dichloropropane	0.005	0.080	0.001	>99%
cis-1,3-dichloropropylene	—	0.079	0.001	>99%
dinoseb	0.007	0.170	0.0002	99%
endrin	0.002	0.053	0.00059	99%
ethylbenzene	0.7	0.088	0.001	>99%
ethylene dibromide (EDB)	0.00005	0.044	0.00002	>99%
haloacetonitriles (HAN)				
bromochloroacetonitrile	—	0.022	0.0005	98%
dibromoacetonitrile	—	0.024	0.0006	98%
dichloroacetonitrile	—	0.0096	0.0002	98%
trichloroacetonitrile	—	0.015	0.0003	98%
haloketones (HK)				
1,1-dichloro-2-propanone	—	0.0072	0.0001	99%
1,1,1-trichloro-2-propanone	—	0.0082	0.0003	96%
heptachlor (H-34, Heptox)	0.0004	0.025	0.00001	>99%
heptachlor epoxide	0.0002	0.0107	0.0002	98%
hexachlorobutadiene	—	0.044	0.001	>98%
hexachlorocyclopentadiene	0.05	0.060	0.000002	>99%
lindane	0.0002	0.055	0.00001	>99%
methoxychlor	0.04	0.050	0.0001	>99%
pentachlorophenol	0.001	0.096	0.001	>99%
simazine	0.004	0.120	0.004	>99%
styrene	0.1	0.150	0.0005	>99%
1,1,2,2-tetrachloroethane	—	0.081	0.001	>99%
tetrachloroethylene	0.005	0.081	0.001	>99%
toluene	1	0.078	0.001	>99%
2,4,5-TP (silvex)	0.05	0.270	0.0016	99%
tribromoacetic acid	—	0.042	0.001	>98%
1,2,4-trichlorobenzene	0.07	0.160	0.0005	>99%
1,1,1-trichloroethane	0.2	0.084	0.0046	95%
1,1,2-trichloroethane	0.005	0.150	0.0005	>99%
trichloroethylene	0.005	0.180	0.0010	>99%
trihalomethanes (THMs)				
bromodichloromethane (THM)				
bromoform (THM)				
chloroform (THM)	0.080	0.300	0.015	95%
chlorodibromomethane (THM)				
xylenes (total)	10	0.070	0.001	>99%



Clean Water Machine 1-Year Limited Warranty

WHO IS COVERED

AQUASANA AND ITS SUPPLIERS, (herein collectively referred to as "Manufacturer") warrants to the original owner who purchased and installed the system (hereinafter "Owner"). Registration of the product is not required to receive warranty coverage as specified in this document. If you purchased from an AquaSana-authorized reseller or dealer, proof of purchase is required.

WHAT IS COVERED

This Warranty covers defects in materials or workmanship during the limited Warranty period of your of your AquaSana Water Filtration System including sub-components purchased with original system (may or may not include faucet and fittings), except as provided below. The water filter is warranted only when it is installed, operated and maintained in accordance with the instructions accompanying the water filter found on AquaSana.com. A water filter should be installed in such a manner that, if the system or any connection thereto should leak, the resulting flow of water will not cause damage to the area in which it is installed. For detailed instructions read the manual accompanying the water filter and review drawings in the manual.

FOR HOW LONG

This Warranty runs for 12 months (365 days) from the date of purchase by a consumer (hereinafter "Warranty Period"). No Warranty coverage will be provided if the claimant is unable to provide proof of purchase from an authorized AquaSana reseller. Estimated lifespan of products is for information only and is based on usage approximations. Water conditions and use rates may limit the functional lifespan of your filter. This Limited Warranty does not extend to the full estimated life span of the system.

WHAT AQUASANA WILL DO

1. If necessary, the Manufacturer will provide a replacement that fulfills the remaining estimated lifespan/capacity of your original purchase and send it to you with installation instructions. If industry standards, product improvements or product obsolescence prohibit Manufacturer from furnishing an identical model replacement water filter under this Warranty, the Owner will be furnished with a new water filter of comparable remaining capacity and functionality; however, the Owner will be charged for the additional value of the item(s) which Manufacturer has incorporated in the replacement water filter. The Warranty period for any replacement will run for the balance of the original 365 days.

2. Component Part – If any component part proves to Manufacturer's satisfaction to be defective in material or workmanship within the Warranty period listed on the data plate label, the Manufacturer will furnish the Owner with a replacement for the defective part(s).
3. Return of Defective Water Filter and Component Parts – Manufacturer reserves the right to examine the alleged defect in the water filter or component part(s), and it will be the Owner's obligation to return the water filter and/or component part(s) to the Manufacturer at the Manufacturer's request.
 - a. When returning a water filter, it must include all component parts.
 - b. When returning component part(s), they must be individually tagged and identified with the water filter's model number, date of purchase, and date of installation.

WHAT IS NOT COVERED

1. This Warranty does not cover filter cartridges and any systems that were not installed in compliance with the instructions or that have been abused or operated incorrectly.
2. This Warranty applies only to products purchased from AquaSana or an AquaSana-authorized reseller or dealer.
3. Except when specifically prohibited by the applicable state law, the Limited Warranty stated herein is in lieu of any and all warranties, express or implied (whether written or oral), including, but not limited to, the implied warranties of merchantability and fitness for a particular purpose.
4. Except when specifically prohibited by the applicable state

law, the Manufacturer shall not be liable for any incidental, consequential, special, or contingent damages or expenses, arising, directly or indirectly, from any defect in the water filter of the use of the water filter.

5. Manufacturer shall not be liable for any water damage arising, directly or indirectly, from any defect in the water filter or component part(s) or from its use.
6. Manufacturer shall not be liable for any damage or product failures caused by any of the following:
 - The water filter or any of its component parts have been subject to misuse, alteration, neglect or accident.
 - The water filter has not been installed in accordance with the applicable local plumbing and/or building code(s) and/or regulations or in their absence.
 - The water filter is not installed, operated and maintained in accordance with the printed Manufacturer's instructions, including if the water filter has any additional aftermarket equipment introduced into the sealed system not approved by the manufacturer.
 - The water filter is exposed to highly corrosive conditions.
 - The water filter is not continuously supplied with potable water.
 - The water filter is not operated within the factory calibrated temperature limits.
 - The water filter is installed in direct sunlight or exposed to freezing temperatures.
 - The water filter or any of its component parts fail due to sediment build-up.
 - Clogging due to purchaser's failure to replace the filter cartridges.
 - Damage caused by fire, flood or acts of God.
 - Damage caused by over-pressurization in the water line.
7. Manufacturer shall not be liable for any claims related to excessive noise, smell, or taste of water.
8. This Warranty does not cover damage caused by the use of parts that are not genuine AquaSana parts. This includes, but is not limited to replacement filters, faucets, and/or diverter valves.
9. Except when specifically prohibited by the applicable state law, the Owner, and not the Manufacturer, shall be liable for and shall pay for all charges for labor or other expenses incurred in the removal, repair or replacement of the water filter or any component part(s) claimed to be defective or any expense incurred to remedy any defect in the product. Such charges may include, but are not necessarily limited to:
 - a. All freight, shipping, handling and delivery costs of forwarding a new water filter or replacement part(s) to the owner.
 - b. All costs necessary or incidental in removing the defective water filter or component part(s) and installing a new water filter or component part(s).
 - c. Any material required to complete, and/or permits required for, installation of a new water filter or replacement part(s), and
 - d. All costs necessary or incidental in returning the defective water filter or component part(s) to a location designated by the Manufacturer.
10. This warranty provides specific legal rights and limitations, but you may have other rights under applicable state law.

HOW TO GET SERVICE

To receive service under this Warranty, you must contact AquaSana (A. O. Smith Water Treatment (North America), Inc.) at 1-866-662-6885 or support@aquasana.com within the Warranty Period to describe the problem to a customer service representative who will verify that the product is under Warranty and determine whether a part or the system will be replaced and whether you must send back the unit. You will be required to provide both proof of purchase and proper installation.

HOW STATE LAW APPLIES

This Warranty gives you specific rights and you may have other rights which vary from state to state.



**Protect your investment and save money
with our Water for Life® program.**



**Extended
Warranty**



**Discount
Replacements**



**Free
Shipping**



**No
Contract**

CONTACT US TO LEARN MORE 866-662-6885

waterforlife@aquasana.com



LOVE IT?

Please let us know with a review on Aquasana or your retailer's website.



NEED HELP?

Give us a call at
866-662-6885 and
tell us what's going on.

Aquasana, Inc.
6310 Midway Road
Haltom City, Texas 76117
866.662.6885 USA
877.332.7873 Canada
www.aquasana.com

AQ-CWM2-B-OM-2025

