

# MyGenie

X SONIC

## Instruction Manual

Thank you for purchasing this product. This product has been made to high quality standards and is guaranteed for domestic use against manufacturing faults for a period of 12 months from date of purchase.



For correct usage, read these instructions carefully.

# **Table of Contents**

1.Safety Regulations	<b>3</b>
2.Product Composition	<b>5</b>
2.1 Component Name	
2.2 Technical Parameter	<b>8</b>
3.Product Composition	<b>9</b>
3.1 Considerations	<b>9</b>
3.2 Rapid Operations	<b>10</b>
3.3 Mode Selection	<b>13</b>
3.4 Use of Water Permeable Rag	<b>15</b>
3.5 Roller Brush Assembly	<b>16</b>
4.Maintenance	<b>17</b>
4.1 Dust Box and Filter	<b>17</b>
4.2 Water Tank Assembly	<b>18</b>
4.3 Rolling Brush and Side Brushes	<b>19</b>
4.4 Other Assembly	<b>20</b>
5.Light Effect and Alarm Tips	<b>21</b>
5.1 Light Effect	<b>21</b>
5.2 Alarm Tips	<b>22</b>
6.FAQ	<b>23</b>

# 1.Safety Regulations

When using the product, please keep your vigilance and follow below information.  
**Please read the manual carefully before using the product. Please keep instruction.**

- 1) Products cannot be used by children under 8 years of age or people with mental disabilities. If you need to use it, please do so under the supervision of a guardian. Please do not let children ride on the product or play with the product as a toy.
- 2) Problems that may arise in cleaning should be removed as early as possible. Remove power cords and small items off the floor to prevent the product from being blocked during the cleaning process. Fold the edge of the carpet to the underside of the carpet, and keep the hanging curtains, tablecloths, etc. from touching the ground.
- 3) If there is a suspended environment such as a staircase, test the product first to see if it can detect the edge of the suspended area without falling. Protective barriers should be installed at the edge of the suspended area to prevent falling products. Make sure that the protective equipment does not cause personal injury.
- 4) Please follow the manual for instructions to use the product. Use only accessories recommended or sold by the manufacturer.
- 5) Ensure that the power supply voltage meets the voltage indicated on the cradle.
- 6) Used only in indoor home environments. Do not use in outdoor, commercial or industrial locations.
- 7) Use only original rechargeable batteries and charging docks that are unique to the manufacturer. Do not use non-rechargeable batteries. For battery specifications, please refer to "Technical Data".
- 8) Ensure that dust boxes and filter materials are installed before using products.
- 9) Use of the product in an environment with open flames or fragile items is prohibited.
- 10) Do not use the product in extreme heat (above 40 ° C) or very cold (below -5 ° C).
- 11) It is a hazard if hair, clothes, fingers and other parts get caught in the opening and operating parts of the product. Please switch off straight away if an incident occurs to avoid further injury.
- 12) Do not use the product in a room where infants are present.
- 13) Do not use the product on wet ground.
- 14) Avoid items such as rocks, waste paper and any other products that may block the product.
- 15) Do not allow the product to come into any flammable materials such as toner for printers or copies. Do not use the product in a clean area with flammable materials.
- 16) Do not take any product that is burning, such as cigarettes, matches, ash, or other items that may cause a fire.

# 1.Safety Regulations

- 17) Do not place items at the suction outlet. Do not use product when suction is blocked. Clean dust, cotton wool, hair at the suction port to ensure smooth air circulation at the suction port.
- 18) Use the power cord carefully to avoid damage. Do not use the power cord to drag or pull the product and the product charging stand. Do not use the power cord as a handle. Do not clamp the power cord into the door seam. Do not pull the power cord at sharp corners. Do not operate the product on the power line, and the power cord should be kept away from heat.
- 19) If the power cord is damaged, it must be replaced by the manufacturer to avoid danger.
- 20) Do not use any damaged charging stands.
- 21) Do not use the product with a damaged power cord or power outlet. Do not use the product when it is not working properly due to dropping, damage, outdoor use or water ingress. To avoid injury, the product should be repaired by the manufacturer or its after-sales service.
- 22) Turn off the product switch before cleaning and maintaining the product.
- 23) The plug must be unplugged from the power outlet before cleaning and maintaining the product.
- 24) If discarding the product, remove the product from the charge stand, turn off the product power switch, and remove the battery.
- 25) The product battery must be removed and discarded in accordance with local laws and regulations before disposing of the product.
- 26) Even if the product has been severely damaged, it is a hazard to incinerate the product, and the product battery as it may cause an explosion.
- 27) If you do not use the product for a long time, please turn off the product.
- 28) Please follow the instructions in the manual to use the product. The company is not responsible for any loss or damage caused by improper use.

## 2.Product Composition

### 2.1 Assembly Name

#### ► Master

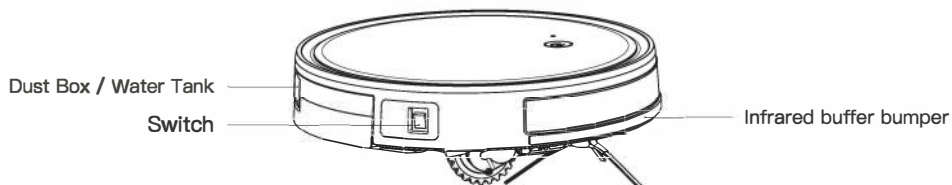
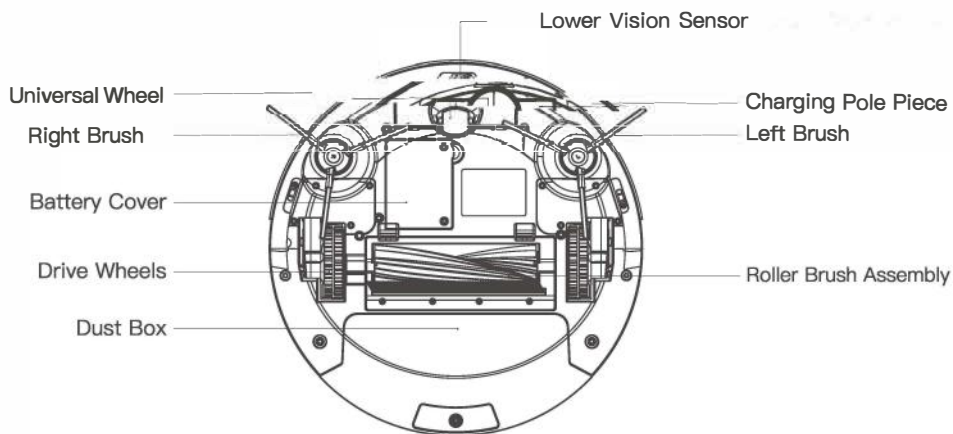
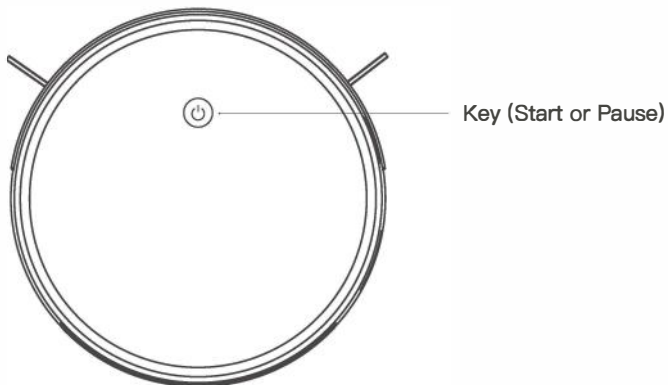

## 2.Product Composition

### ► Charging Stand Assembly

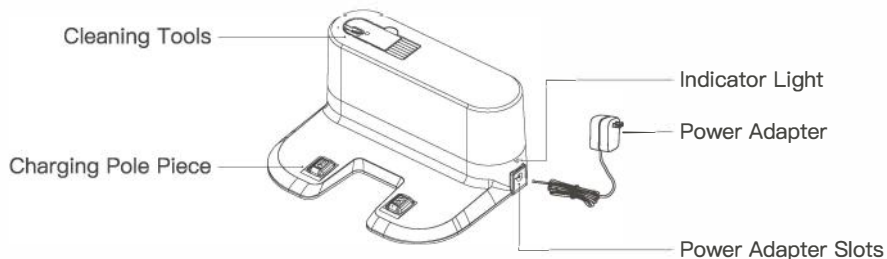

### ► Remote Control

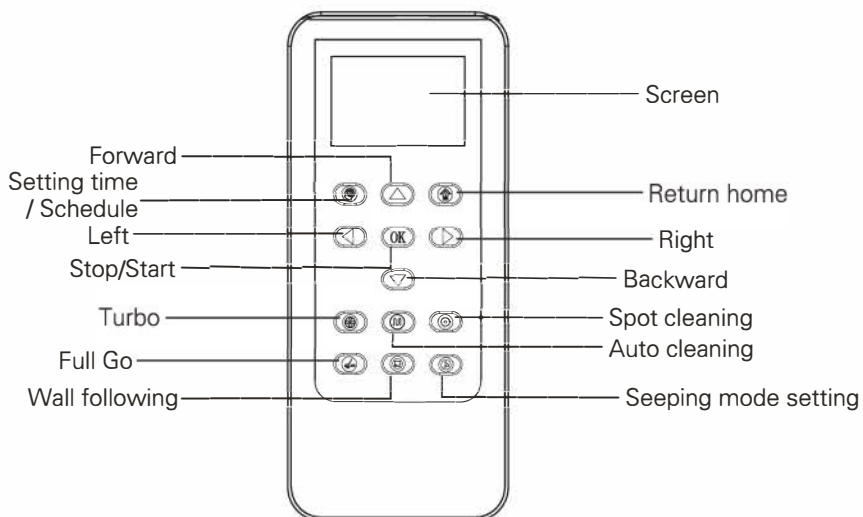

## 2.Product Composition

### ► Dust Box

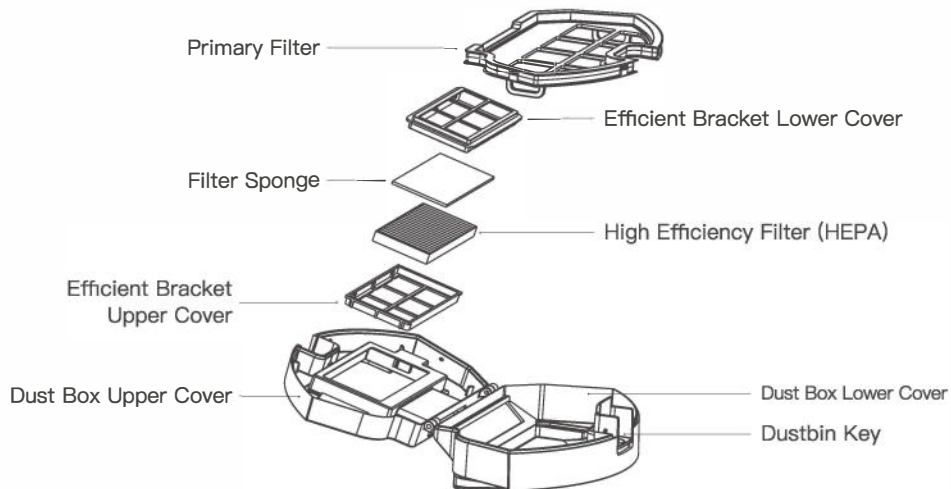

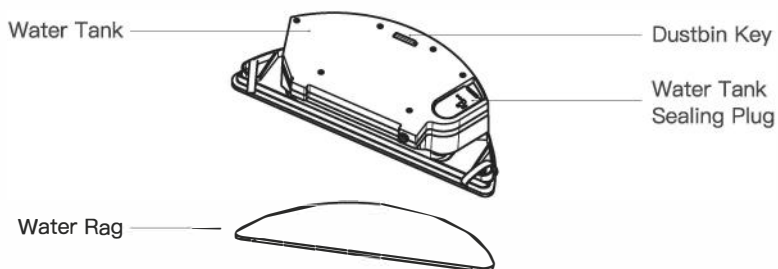

### ► Water Permeable Rag Assembly



## 2.Product Composition

### 2.2 Technical Parameters

<b>Master</b>	
Working Voltage: 10.89 V 	Power Rating: 20W
<b>Charging Stand</b>	
Rated Input Voltage: 19 V 	Rated output current: 0.6A
<b>Battery and Specifications</b>	Lithium Battery 2600mAh
<b>Adapter :</b> Output parameter 100–240V ~50/60HZ Input parameter 19VDC/0.6A	

## 3.Product Composition

### 3.1 Considerations

Please refer to the following guidelines to check the cleaning area before the turning on the unit for a more efficient clean.



Power lines and other debris scattered on the ground may trip up and must be removed before.



Please roll the carpet tassels or work on short-hair rugs.



A gap of less than 8 cm on the bottom of the furniture may catch the product. If you need to clean it, please raise the furniture.



A guard rail should be placed at the edge of the duplex to ensure safe operation of the product.

# 3.Product Composition

## 3.2 Rapid Operation

### Charging Preparation

#### 1 Connect the adapter to the charging stand.

Place the charging stand flat against the wall. Do not place objects in the left and right 1M and the front 2M, and do not have objects with strong reflection surfaces such as mirrors.

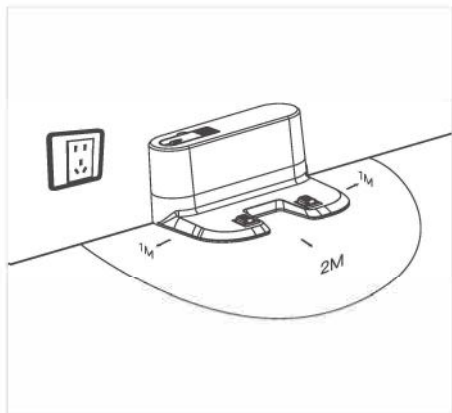

Place the charging stand

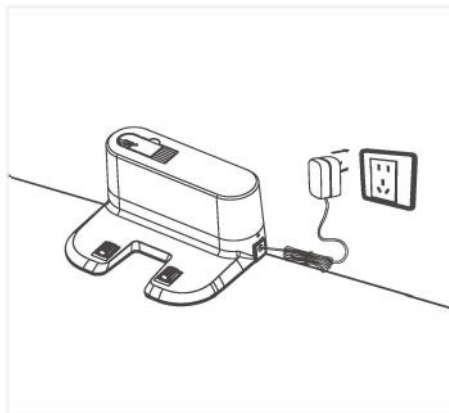

Connect the power supply

#### 2 Install the Side Brushes.

Please install the right brush into the right bottom mounting port of the machine, the left brush into the left bottom mounting port of the machine and ensure that the two side brushes are in place.

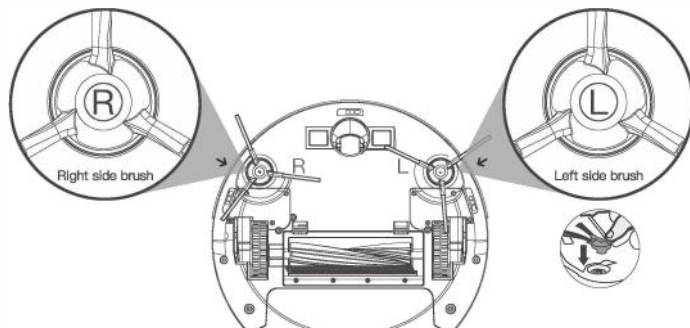

## 3.Product Composition

### Start to charge.

#### 1 Turn on the Master.

Turn on the side power switch, "I" is the turn on, "O" is the turn off.

After the master finishes working, it is recommended not to shut down; keep the master in a state of charge so that it can perform its next job better.

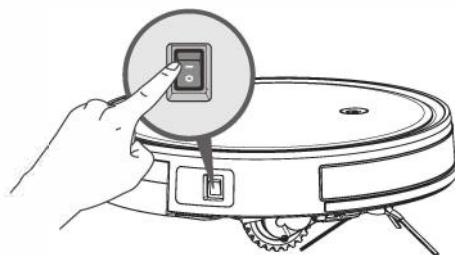

#### 2 Master Charge

Place the master in the charging stand and pay attention to the charging pole piece.

Turn on the power switch, the robot will enter standby mode. ⏻ Red light/pink light/Blue light breathing light flashes indicate charging. ⏻ When the blue light is off means charging is completed. For the first use, please charge continuously for more than 12 hours.

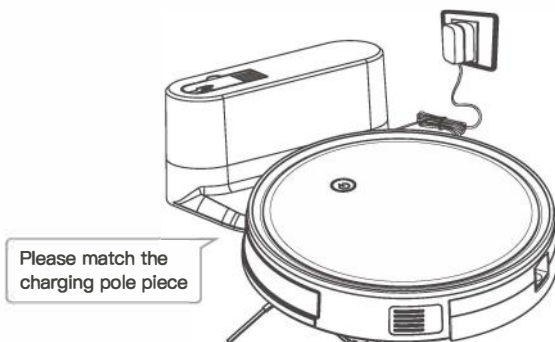



## 3.Product Composition

### Start Cleaning

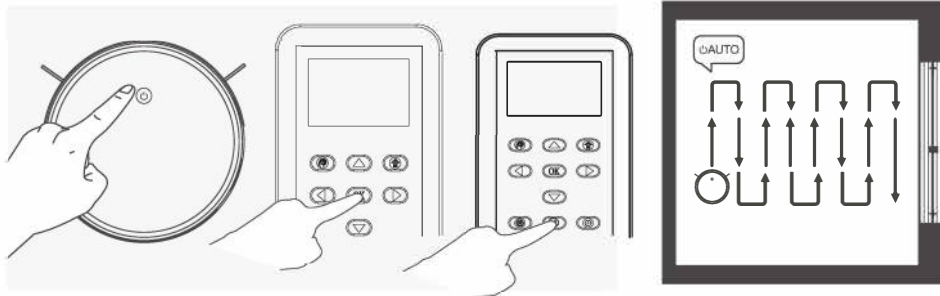
Start the Automatic Cleaning Mode with the master's  key or remote control  key



Before starting the mode, make sure that the outer ring of the  key is red/blue and the master is in the state of being awakened. If the master does not wake up, short press the master  or remote control  key to wake it up.

The master enters the sleep state after 10 minutes of standby, and the  key light is off.

If you need to select another mode, please refer to the (Mode Selection) section.

### Stop Working

While the master is working, press the master  key or remote control and the master will pause.

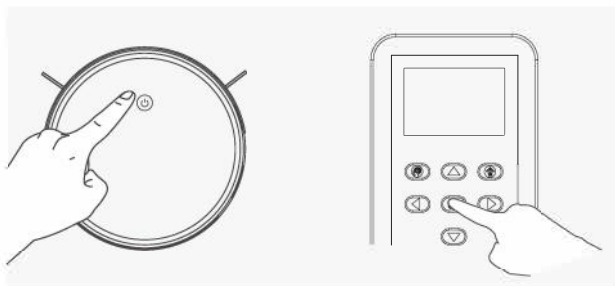



## 3.Product Composition

### 3.3 Mode Selection

In order to adapt to different ground conditions and achieve deeper clean, this product has a variety of cleaning modes, which can be selected by remote control as needed.

The remote control can switch any mode directly.

Before starting the mode, make sure that the outer ring of the  key is red/blue and the master is in the state of being awake. If the master does not wake up, short press the master  or remote control

 key to wake it up.

#### Fixed-Point Mode

It is suitable for the ground environment where the garbage is concentrated. The master centralized cleaning in the designated area, and master centralized cleaning with the "spiral" route. After the diameter is 1m, the machine returns to the original point. If the obstacle is encountered in the middle, the spiral is cleaned for 2 minutes.

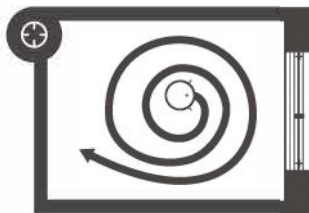
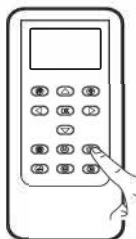

#### Edge Mode

It is suitable for cleaning at the corners of the room. The master is cleaned around the periphery of a fixed object (such as a wall) and cleaned back to the charging stand.

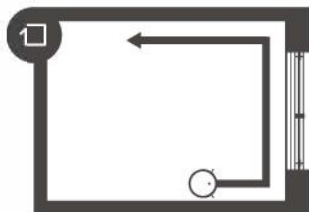
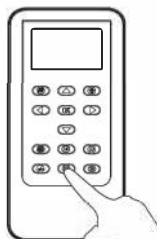

#### Return Charging Mode

It can also be commanded by the button on the remote control to start the "return charging" mode. During the cleaning process, the master can sense that its own power is insufficient, and automatically start the "return charging" mode, and automatically find the charging stand for charging.

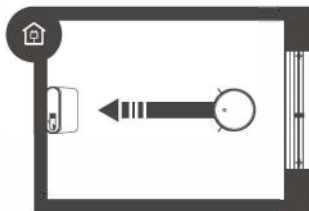
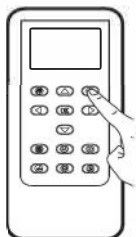

## 3.Product Composition

### Turbo Mode

Robot will increase suction. Suitable for a very dirty floor or a thick carpet.

**!** Turbo mode cannot be accessed while using the mop cleaning method.



## Time and Date Settings

### 1. Programming the Time and Date

#### a. Settings of current weekday:

In the standby mode, press the "●" button to enter the setting of current week day; press the "◀" "▶" buttons to switch Monday/Sunday; press the "OK" to save the current week day and enter the setting of current hour/minute.

#### b. Settings of current hour/minute:

After the settings of current week day is done, then enter the specific settings of current hour/minute.

press the "◀" "▶" buttons to switch hour/minute.

press the "▲" buttons to increment the current time, and press the "▼" button vice versa;

press the "OK" buttons to save the current hour/minute.

### 2. Scheduling a Routine Cleaning

#### a. Settings of Schedule week day:

In the standby mode, press the "●" button on the remote controller 4 seconds to enter the settings of schedule week day;

press the "◀" "▶" buttons to switch Monday/Sunday;

press the "OK" to save the appointed week day and enter the setting of appointed hour/minute.

After the settings of schedule week day is done, press the "▲" button on the remote controller to save, press the "▼" button on the remote controller to cancel, then press

the "OK" button on the remote controller to save, enter the settings of appointed hour/minute.

#### b. Settings of Schedule hour/minute:

Press the "◀" and "▶" buttons to switch hours/minute;

Press the "▲" buttons to increment the appointed time, and press the "▼" button vice versa;

Press the "OK" buttons to save the setting of appointed hour/minute.

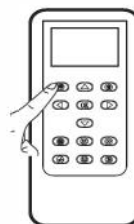

## 3.Product Composition

### 3.4 Use of Water Permeable Rag

This product is equipped with a water tank assembly. After the cleaning work is completed, if there is a demand for mopping, the dust box can be replaced with a water tank assembly. For the cleaning method, please refer to the [Maintenance] section in this manual.

Do not use the water tank assembly on the carpet. When cleaning with the rag function, fold the edge of the carpet to avoid foreign matter on the rag from soiling the carpet.

In the cleaning, please pay attention, add water or clean up in time, remove the water storage box when adding water. When charging, be sure to remove the water permeable wiper assembly.

#### ■ Add Water

Open the water inlet cover and take enough water.

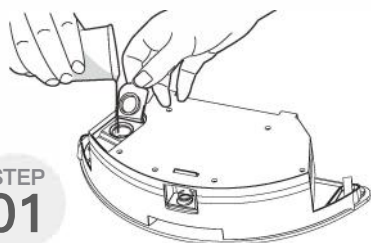

STEP  
01

#### ■ Sticking the Water Rag

Close the water inlet cover and stick the water rag.

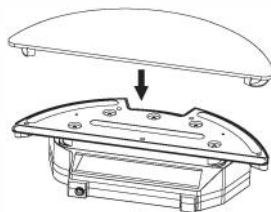

STEP  
02

#### ■ Install Water Tank Assembly

Press the dust box release button at the rear of the master to remove the dust box and replace the water tank assembly.

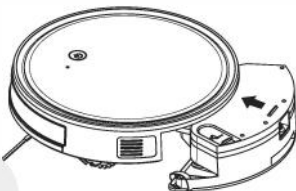

STEP  
03

#### ■ Mop

Start any cleaning mode as needed, and the master will perform cleaning and mopping.

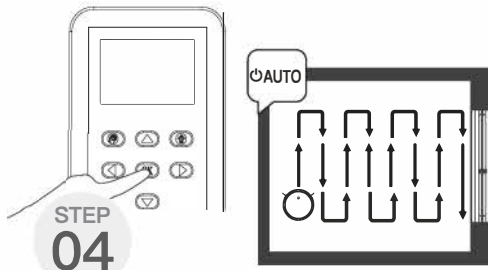

STEP  
04

## 3.Product Composition

### 3.5Roller Brush Assembly

#### Assembly Choices

##### Roller brush assembly:

Scratch the floor, sweep effectively.



**Set roller brush assembly:** set the roller brush and cover the board and then press to lock.



## 4.Maintenance

### 4.1 Dust Box and Filter

When cleaning and maintaining the master and its accessories, turn off the master and unplug the charging stand.

- Remove the dust box, open the dust box cover, and clean the garbage.

STEP  
01

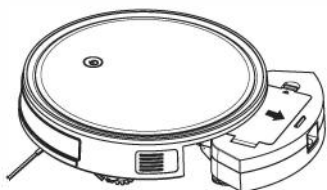

- Remove dust filter. HEPA is not recommended for washing. Please pat and remove ash.

STEP  
02

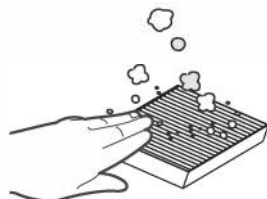
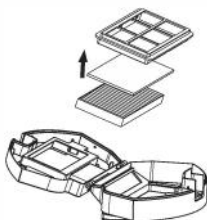
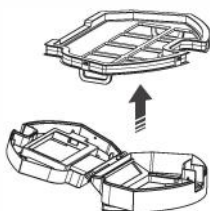

- Flush the dust box and the primary filter.

STEP  
03

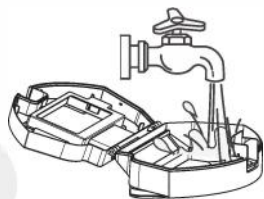

- Dry the dust box and dust filter assembly and keep it dry to ensure its service life.



STEP  
04

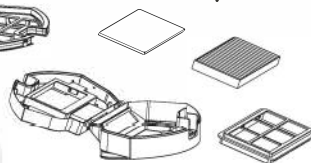

## 4. Maintenance

### 4.2 Water Tank Assembly

#### Cleaning of Water Rag

- **Remove:** After the mopping is completed, remove the water tank assembly, and remove the water permeable rag.

STEP  
01

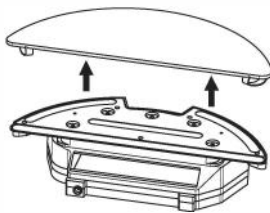
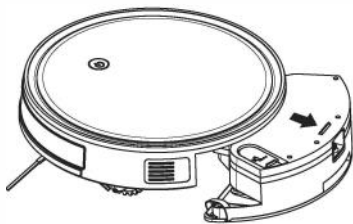

- **Maintenance:** Rinse and dry the water rag

STEP  
02

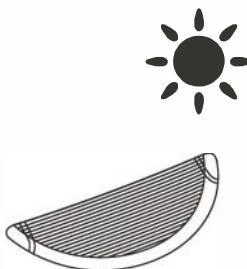

#### ■ Cleaning the Water Reservoir

**Remove:** After mopping the floor, remove the water tank assembly, remove the water permeable cloth, and pour off the remaining water in the water reservoir.

**Maintenance:** Dry the reservoir and allow it to dry.

STEP  
03

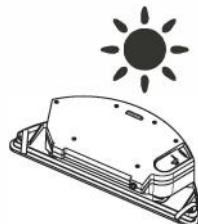
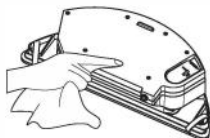
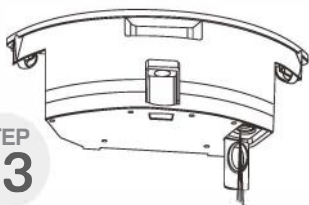

## 4.Maintance

### 4.3 Rolling Brush、 Side Brushes

#### ■ Cleaning Rolling Brush

Remove the rolling brush cover plate, remove the rolling brush, cut off the hair round on the rolling brush, and facilitate cleaning.

STEP  
01

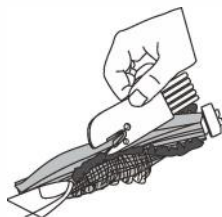
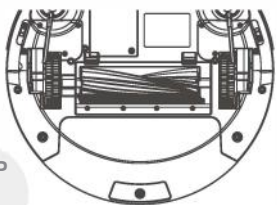

#### ■ Cleaning Side Brushes

Pull out the side brush and wipe it with a clean rag.

STEP  
02

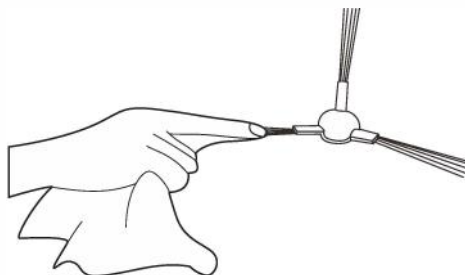

## 4.Maintenance

### 4.4 Other Assembly

- Clean the universal wheel to reduce hair entangled.

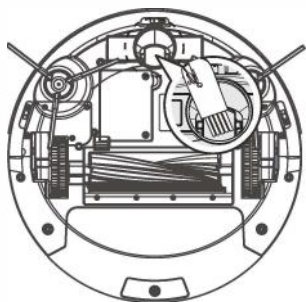

- Clear down the sensor to ensure the sensitivity of the sensor.

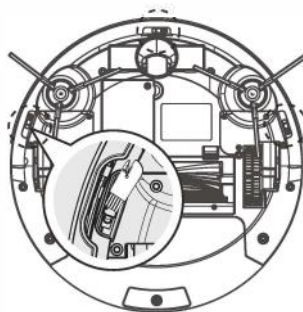

- To clean the charging pole pieces, use a dry rag to clean the charging poles on the bottom of the master or the charging stand.

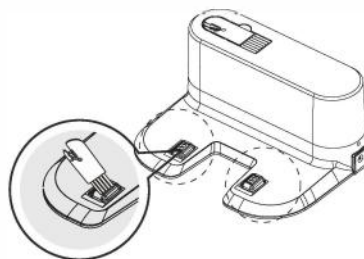
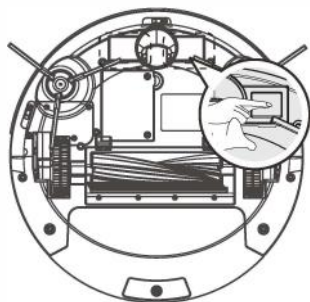

Do not use this product for a long time, please remove the battery and keep it in a safe place. If the battery leaks, remove the battery and wipe the battery compartment clean.

This product uses a high-life battery and does not require frequent replacement. If you need to replace, you can contact after-sales service replacement.

## 5. Lighting Effects And Alarm Tips

### 5.1 Lighting Effects

Cleaner status	AUTO Display Status
Cleaner stop cleaning	Blue lamp light on
Start auto charge	Purple & blue lamp light on
Start to Spiral clean	Blue lamp light on
Start to wall follow cleaning	Blue lamp light on
Start recharging	Blue lamp flash
Start zigzag clean	Blue lamp light on
Switch on	Blue lamp light on (red lamp means low power)
Start to mopping mode	Blue lamp light on
Low power, Start to auto charge	Blue lamp light on
Press any direction button	"non"
Connect successfily	Blue lamp light on

# 5 Lighting Effects And Alarm Tips

## 5.2 Alarm Tips

When the host fails, the red light of the outer ring of the host key flashes, and the buzzer sounds of different lengths will be emitted. Refer to the following table to check the cause of the fault:

Cleaner status	AUTO Display Status	Solution
Side brush error	Red lamp light on <u>two sounds three times</u>	Please check if the side brush is entangled and clean the side brushes.
Fan motor error	Red lamp light on <u>three sounds three times</u>	Please check the garbage and air duct outlet.
Main brush error	Red lamp light on <u>four sounds three times</u>	Please check if the roller brush is entangled and clean the roller brush.
Dustbin error	Red lamp light on <u>five sounds three times</u>	Please check whether dustbin put in position.
Ground sensor error	Red lamp flash <u>two sounds three times</u>	Clean the cliff sensor ground detector or manually pick up the cleaner if wheel is not on the floor.
Cleaner trapped	Red lamp flash <u>three sounds three times</u>	Please move to the open space.
Low power, need charge manually	Red lamp flash <u>four sounds three times</u>	Manually move the cleaner back to the dock station recharging.
Adapter failure	Red lamp flash <u>five sounds three times</u>	Please use 19V 0.6A adapter for charging.

### Tips

If the above method does not solve the problem, please try the following: the power switch on the side of the master and restart the machine.

## 6.FAQ

If the following problems occur during the use of the product, you can solve it yourself by checking the queries.

No	Cause of Failure	Probable Reasons	Solution
01	Master cannot charge	The master is not in full contact with the charging pole of the charging stand.	Make sure that the master is fully docked with the charging poles of the cradle.
		off and the main power switch is turned on, resulting in power loss.	When the master does not work, it is recommended to keep it in charge so that it can carry out the next work better
02	The master is in trouble when working	The master is entangled or obstructed by scattered wires on the ground, drape curtains or carpet edges.	The master will try various ways to get rid of difficulties, if you are not able to get out of trouble, it is recommended to help manually
03	After the cleaning is completed, the host returns to charging.	When the master is working, it can sense that the battery is low and automatically returns to charging.	Charge the master
		Wooden floor, tile and other flat ground master speed and time difference	The working time of the master varies depending on the complexity of the room, the amount of garbage and the cleaning mode.
04	The master did not automatically clean up according to the scheduled time	The master power switch is not turned on, and the master is in the off state to clear the reservation information on the master side.	Turn on the power switch of the master, reconnect the network and use the APP to determine the reservation information.
		The master is low on battery.	When the master is in standby, it should be kept on the charging stand to ensure that it has sufficient power to work at any time.
		The master is clogged and tangled by garbage	Turn off the power and clean the dust box with the bottom of the master facing up. Clean each part separately.
05	The remote control is out of order. (the remote control has an effective control range of 5 meters)	The remote control is low on battery.	Replace the battery with a new one and install it properly.
		Master power switch is not turned on or master is not enough power.	Make sure the master power switch is turned on and has sufficient power to complete the operation
		The infrared emission of the remote control or the master receiver is dirty and cannot transmit or receive signals.	Wipe the infrared emitter of the remote control and the infrared receiver of the master with a clean cotton cloth.
		There is a device interference signal that generates infrared rays near the master.	Avoid using the remote control near other infrared devices.
06	Master cannot be charged	The master is not in full contact with the charging pole of the charging stand.	



[www.mygenieshop.com.au](http://www.mygenieshop.com.au)



## Consumer Warranty

MyGenie would like you to enjoy your new purchase.  
This warranty card is provided to ensure that you get satisfaction.

Our goods come with guarantees that cannot be excluded under Australian Consumer Law.

You are entitled to a replacement or refund for a major failure for any other reasonably foreseeable loss or damage.

You are also entitled to have the goods repaired or replaced if the goods fail to be of acceptable quality and the failure does not amount to a major failure. The benefits of this warranty are in addition to the consumer's rights and remedies under law.

### Warranty Period

The warranty is 12 months from the date of purchase

### Registering Your Purchase

Please register your purchase on [www.mygenieshop.com.au](http://www.mygenieshop.com.au)

### Procedure for claiming under warranty

Should you need to make a claim under this warranty please email direct to [support@mygenieshop.com.au](mailto:support@mygenieshop.com.au)

**Please retain your original receipt as proof of purchase**