



**DRAPER**<sup>®</sup>

# DUAL ACTION AIR **COMPOSITE SANDER**

65084



CE

These instructions accompanying the product are the original instructions. This document is part of the product, keep it for the life of the product passing it on to any subsequent holder of the product. Read all these instructions before assembling, operating or maintaining this product.

This manual has been compiled by Draper Tools describing the purpose for which the product has been designed, and contains all the necessary information to ensure its correct and safe use. By following all the general safety instructions contained in this manual, it will ensure both product and operator safety, together with longer life of the product itself.

All photographs and drawings in this manual are supplied by Draper Tools to help illustrate the operation of the product.

Whilst every effort has been made to ensure the accuracy of information contained in this manual, the Draper Tools policy of continuous improvement determines the right to make modifications without prior warning.

# 1. TITLE PAGE

---

## 1.1 INTRODUCTION:

**USER MANUAL FOR: Dual Action Composite Air Sander**

**Stock No: 65084**

**Part No: DAT-APS-SF**

## 1.2 REVISIONS:

---

**Date first published November 2014.**

---

**Date of first revision: July 2020.**

---

---

As our user manuals are continually updated, users should make sure that they use the very latest version.

**Downloads are available from:** <http://drapertools.com/manuals>

Draper Tools Limited  
Hursley Road  
Chandler's Ford  
Eastleigh  
Hampshire  
SO53 1YF  
UK

**Website:** [drapertools.com](http://drapertools.com)

**Product Help Line:** +44 (0) 23 8049 4344

**General Fax:** +44 (0) 23 8026 0784

## 1.3 UNDERSTANDING THIS MANUALS SAFETY CONTENT:

**Warning!** – Information that draws attention to the risk of injury or death.

**Important** – Information that draws attention to the risk of damage to the product or surroundings.

## 1.4 COPYRIGHT © NOTICE:

Copyright © Draper Tools Limited.

Permission is granted to reproduce this publication for personal and educational use only.

Commercial copying, redistribution, hiring or lending is prohibited.

No part of this publication may be stored in a retrieval system or transmitted in any other form or means without written permission from Draper Tools Limited.

In all cases this copyright notice must remain intact.

# 2. CONTENTS

---

## 2.1 TABLE OF CONTENTS

### 1. TITLE PAGE

1.1	INTRODUCTION:.....	2
1.2	REVISIONS:.....	2
1.3	UNDERSTANDING THIS MANUALS SAFETY CONTENT:.....	2
1.4	COPYRIGHT © NOTICE:.....	2

### 4. INTRODUCTION

4.1	SCOPE.....	5
4.2	SPECIFICATION.....	5
4.3	HANDLING AND STORAGE.....	5

### 5. HEALTH AND SAFETY INFORMATION

5.2	GENERAL SAFETY INSTRUCTIONS FOR COMPRESSED AIR.....	7
5.3	ADDITIONAL SAFETY INSTRUCTIONS FOR AIR SANDERS.....	8
5.4	RESIDUAL RISK.....	8

### 6. TECHNICAL DESCRIPTION

6.1	IDENTIFICATION.....	9
-----	---------------------	---

### 7. UNPACKING AND CHECKING

7.1	PACKAGING.....	10
7.2	WHAT'S IN THE BOX.....	10

### 8. AIR SUPPLY

8.1	AIR TOOL OIL SPECIFICATION.....	11
8.2	RECOMMENDED AIR SUPPLY SET UP.....	11

### 9. ASSEMBLY

9.1	CONNECTION TO THE AIR SUPPLY.....	12
9.2	ATTACHING THE HOOK & LOOP SHEETS.....	12
9.3	DUST COLLECTION.....	12

### 10. OPERATION AND USE

10.1	OPERATION & AIR REGULATION.....	13
10.2	REPLACING THE BACKING PAD.....	13

### 11. MAINTENANCE AND TROUBLESHOOTING

11.1	EVERY-DAY MAINTENANCE CHECKS.....	14
11.2	AFTER USE MAINTENANCE CHECKS.....	14
11.3	TROUBLESHOOTING GUIDE.....	14

### 12. DISPOSAL

12.1	DISPOSAL.....	15
------	---------------	----

### 13. EXPLANATION OF SYMBOLS

13.1	EXPLANATION OF SYMBOLS.....	15
------	-----------------------------	----

## 3. WARRANTY

---

### 3.1 WARRANTY

Draper tools have been carefully tested and inspected before shipment and are guaranteed to be free from defective materials and workmanship.

Should the tool develop a fault, please return the complete tool to your nearest distributor or contact:

**Draper Tools Limited, Chandler's Ford, Eastleigh, Hampshire, SO53 1YF. England.**

**Telephone Sales Desk: +44 (0) 8049 4333 or Product Help Line +44 (0) 23 8049 4344.**

A proof of purchase **must** be provided with the tool.

If upon inspection it is found that the fault occurring is due to defective materials or workmanship, repairs will be carried out free of charge. This warranty period covering parts and labour is 12 months from the date of purchase except where tools are hired out when the warranty period is 90 days from the date of purchase. This warranty does not apply to any consumable parts, any type of battery or normal wear and tear, nor does it cover any damage caused by misuse, careless or unsafe handling, alterations, accidents, or repairs attempted or made by any personnel other than the authorised Draper warranty repair agent.

**Note:** If the tool is found not to be within the terms of warranty, repairs and carriage charges will be quoted and made accordingly.

This warranty applies in lieu of any other warranty expressed or implied and variations of its terms are not authorised.

Your Draper warranty is not effective unless you can produce upon request a dated receipt or invoice to verify your proof of purchase within the warranty period.

Please note that this warranty is an additional benefit and does not affect your statutory rights.

**Draper Tools Limited.**

# 4. INTRODUCTION

---

## 4.1 SCOPE

Composite bodied air sander with hook and loop backing pad, suitable for 150mm/6"Ø abrasive sheets.

## 4.2 SPECIFICATION

Stock No. ....	65084
Part No. ....	DAT-APS-SF
Backing pad diameter.....	150mm/6"Ø
Revolutions per minute (no load).....	10,500r/min
Max. operating air pressure .....	90psi (6.3bar)
Average air consumption.....	3.0cfm (85L/min)
Minimum air line size .....	3/8"ID
Air inlet.....	1/4" BSP
Sound pressure level (LpA).....	85dB(A)
Sound power level (LWA) .....	96dB(A)
Vibration level.....	6.3m/s <sup>2</sup>
Weight .....	0.88kgs

## 4.3 HANDLING AND STORAGE

- Care must be taken when handling this product.
  - Dropping this power tool could have an effect on its accuracy and could also result in personal injury. This product is not a toy and must be respected.
- Environmental conditions can have a detrimental effect on this product if neglected.
  - Exposure to damp air can gradually corrode components. If the product is unprotected from dust and debris, components will become clogged.
  - If not cleaned and maintained correctly or regularly, the machine will not perform at its best.



## 5. HEALTH AND SAFETY INFORMATION

---

### 5.1 GENERAL SAFETY INSTRUCTIONS FOR POWER TOOL USE

When using any type of power tool there are steps that should be taken to make sure that you, as the user, remain safe.

Common sense and a respect for the tool will help reduce the risk of injury.

**Read the instruction manual fully.** Do not attempt any operation until you have read and understood this manual.

Most important you must know how to safely start and stop this machine, especially in an emergency.

**Keep the work area tidy and clean.** Attempting to clear clutter from around the machine during use will reduce your concentration. Mess on the floor creates a trip hazard. Any liquid spilt on the floor could result in you slipping.

**Find a suitable location.** If the machine is bench mounted, the location should provide good natural light or artificial lighting as a replacement. Avoid damp and dust locations as it will have a negative effect on the machine's performance. If the machine is portable do not expose the tool to rain. In all cases do not operate power tools near any flammable materials.

**Keep bystanders away.** Children, onlookers and passers by must be restricted from entering the work area for their own protection. The barrier must extend a suitable distance from the tool user.

Unplug and house all power tools that are not in use. A power tool should never be left unattended while connected to the power supply. They must be housed in a suitable location, away locked up and from children. This includes battery chargers.

**Do not overload or misuse the tool.** All tools are designed for a purpose and are limited to what they are capable of doing. Do not attempt to use a power tool (or adapt it in any way) for an application it is not designed for. Select a tool appropriate for the size of the job. Overloading a tool will result in tool failure and user injury. This covers the use of accessories.

**Dress properly.** Loose clothing, long hair and jewellery are all dangerous because they can become entangled in moving machinery. This can also result in parts of body being pulled into the machine. Clothing should be close fitted, with any long hair tied back and jewellery and neck ties removed. Footwear must be fully enclosed and have a non-slip sole.

**Wear personal protective equipment (PPE).** Dust, noise, vibration and swarf can all be dangerous if not suitably protected against. If the work involving the power tool creates dust or fumes wear a dust mask. Vibration to the hand, caused by operating some tools for longer periods must be protected against. Wear vibration reducing gloves and allow long breaks between uses. Protect against dust and swarf by wearing approved safety goggles or a face shield. These are some of the more common hazards and preventions, however, always find out what hazards are associated with the machine/work process and wear the most suitable protective equipment available.

**Do not breathe contaminated air.** If the work creates dust or fumes connect the machine (if possible) to an extraction system either locally or remotely. Working outdoors can also help if possible.

**Move the machine as instructed.** If the machine is hand held, do not carry it by the power supply cable. If the product is heavy, employ a second or third person to help move it safely or use a mechanical device. Always refer to the instructions for the correct method.

**Do not overreach.** Extending your body too far can result in a loss of balance and you falling. This could be from a height or onto a machine and will result in injury.

**Maintain your tools correctly.** A well maintained tool will do the job safely. Replace any damaged or missing parts immediately with original parts from the manufacturer. As applicable, keep blades sharp, moving parts clean, oiled or greased, handles clean, and emergency devices working.

**Wait for the machine to stop.** Unless the machine is fitted with a safety brake, some parts may continue to move due to momentum. Wait for all parts to stop, then unplug it from the power supply

## 5. HEALTH AND SAFETY INFORMATION

---

before making any adjustments, carrying out maintenance operations or just finishing using the tool.

**Remove and check setting tools.** Some machinery requires the use of additional tools or keys to set, load or adjust the power tool. Before starting the power tool always check to make certain they have been removed and are safely away from the machine.

**Prevent unintentional starting.** Before plugging any machine in to the power supply, make sure the switch is in the OFF position. If the machine is portable, do not hold the machine near the switch and take care when putting the machine down, that nothing can operate the switch.

**Concentrate and stay alert.** Distractions are likely to cause an accident. Never operate a power tool if you are under the influence of drugs (prescription or otherwise), including alcohol or if you are feeling tired. Being disorientated will result in an accident.

**Have this tool repaired by a qualified person.** This tool is designed to conform to the relevant international and local standards and as such should be maintained and repaired by someone qualified, using only original parts supplied by the manufacturer. This will ensure the tool remains safe to use.

### 5.2 GENERAL SAFETY INSTRUCTIONS FOR COMPRESSED AIR

These safety instructions should be strictly followed. Failure to do so may result in accidents, equipment malfunctioning, serious personal injury and / or loss of life.

Compressed air is a source of considerable energy. When handling products dealing with compressed air, the following precautions must be taken to prevent accidents.

- Ensure that compressed air is not blocked or in contact with any part of your body.
- Before connecting any pneumatic equipment to the compressed air supply, all mounted fittings, piping assemblies and electrical connections should be checked for security. All plastic plugs in the equipment used for protection during shipping should be removed.
- No piping alterations, removal of fittings, repairing of equipment etc. Should be attempted with air supplies connected. Air and electrical supplies must be disconnected before beginning any adjustment, maintenance or dismantling of equipment.
- The maximum allowable operating pressures, temperature, flows etc. must be strictly observed. Failure to do so might result in catastrophic failure of equipment, and result in serious personal injury and / or death. Refer to individual catalogues for this information, and any other operating or application limitations.

#### Warning:

##### – **Compatibility of pneumatic equipment**

Ensuring the compatibility of the procured FRL equipment is the responsibility of the person who designs the Pneumatic system and/ or System specifications. This should be based on specifications or after analysis and / or tests to meet specific requirements.

##### – **Repair and maintenance**

Assembly, handling, or repair of pneumatic systems should be performed by only trained and experienced operators.

##### – **Safety first**

Do not service machinery/equipment or attempt to remove any component until safety is confirmed.

- Inspection and maintenance of machinery / equipment should only be performed after confirmation that both compressed air and electrical supply have been positively disconnected and all residual compressed air in the system has been completely exhausted to the atmosphere.
- Contact the manufacturer if equipment is to be used in any of the following conditions:
  - Equipment is to be used in conditions beyond the given specifications, or if equipment is to be used outdoors.

## 5. HEALTH AND SAFETY INFORMATION

---

- Equipment is to be used in conjunction with atomic energy, railroad, air navigation, automobiles or related vehicles, medical equipment or safety equipment.
- In applications that adversely effect humans, animals, or property requiring special safety analysis.

### 5.3 ADDITIONAL SAFETY INSTRUCTIONS FOR AIR SANDERS

**Important:** Draper Tools Limited recommends that this machine should not be modified or used for any application other than that for which it was designed. If you are unsure of its relative applications do not hesitate to contact us in writing and we will advise you.

- Power tools shall not be used in potentially explosive atmospheres unless specifically designed for that purpose.
- Unexpected tool movement due to reaction forces or breakage of inserted tool may cause injuries.
- Air tools shall be isolated from the air line before changing or adjusting the inserted tool.

#### **Warning!**

- There is a risk of loose clothing, hair etc., being caught in the rotating spindle of the air tool.
- There is a risk of being injured if hands are not kept away from the rotating disc.
- There is a risk of being injured by whipping air hoses.
- Use only accessories which are in good condition and are intended for use with air sanders.
- Adopt a suitable posture to counteract normal or unexpected movement of the air tool due to reaction forces from the tool.
- Release the start and stop device in the case of an interruption of the energy supply.
- Only lubricants recommended by the manufacturer shall be used.
- Release pressure when not in use. Disconnect from air line.
- Do not modify this air sander in any way.
- Do not carry or move the tool by the air line.

### 5.4 RESIDUAL RISK

**Important:** Although the safety instructions and operating manuals for our tools contain extensive instructions of safe working with power tools, every power tool involves a certain residual risk which can not be completely excluded by safety mechanisms. Power tools must therefore always be operated with caution!

# 6. TECHNICAL DESCRIPTION

## 6.1 IDENTIFICATION

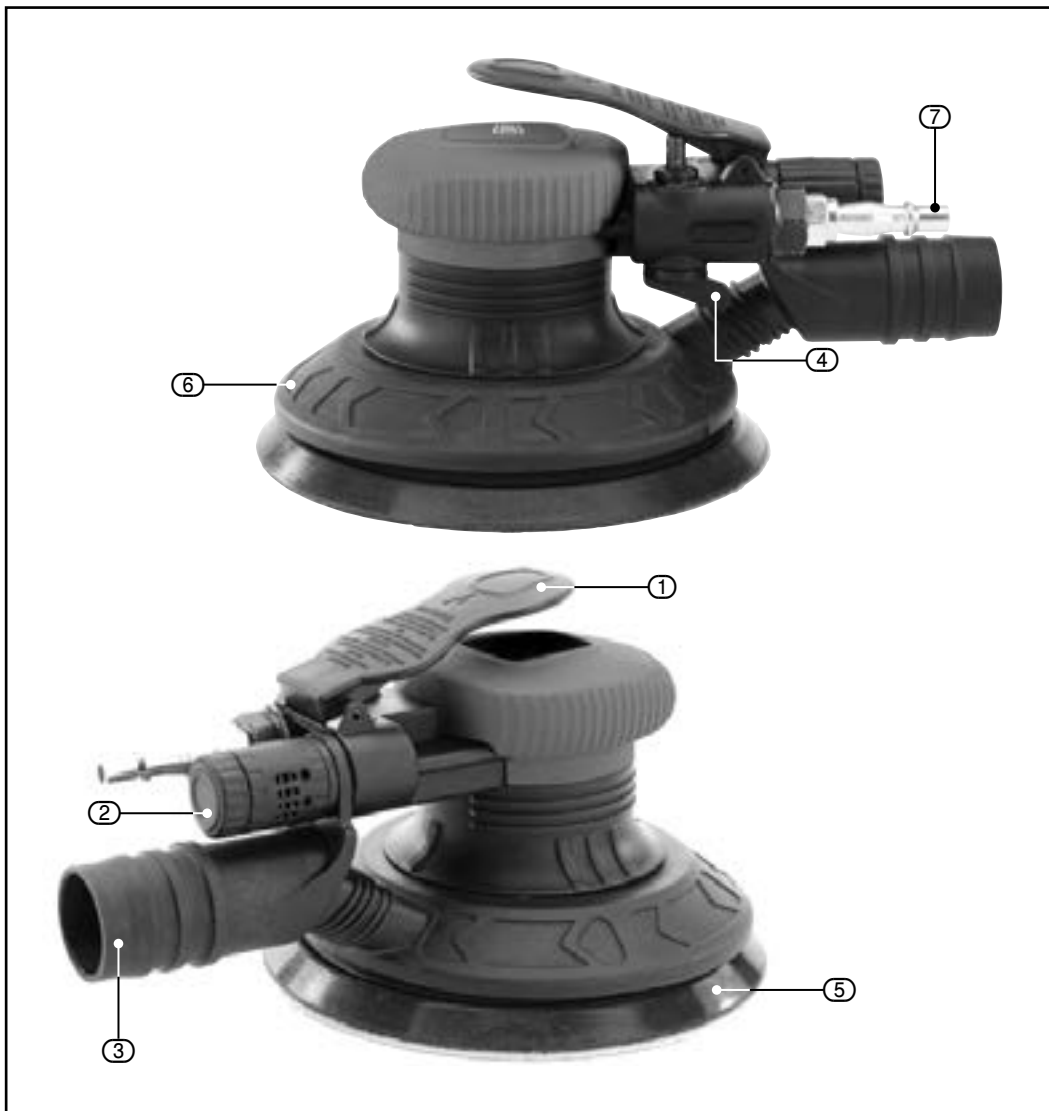

- ① Trigger.
- ② Directional exhaust.
- ③ Dust outlet port.
- ④ Speed adjusting lever.
- ⑤ Sanding backing pad.
- ⑥ Shroud.
- ⑦ Airline coupling adaptor.

## 7. UNPACKING AND CHECKING

---

### 7.1 PACKAGING

Carefully remove the product from the packaging and examine it for any sign of damage that may have happened during shipping. Lay the contents out and check them against the parts shown below. If any part is damaged or missing, please contact the Draper Help Line (the telephone number appears on the Title page) and do not attempt to use the product.

The packaging material should be retained at least during the warranty period, in case the machine needs to be returned for repair.

#### Warning!

- Some of the packaging materials used may be harmful to children. Do not leave any of these materials in the reach of children.
- If any of the packaging is to be thrown away, make sure they are disposed of correctly, according to local regulations.

### 7.2 WHAT'S IN THE BOX

As well as the main product, there are several parts not fitted or attached to it.

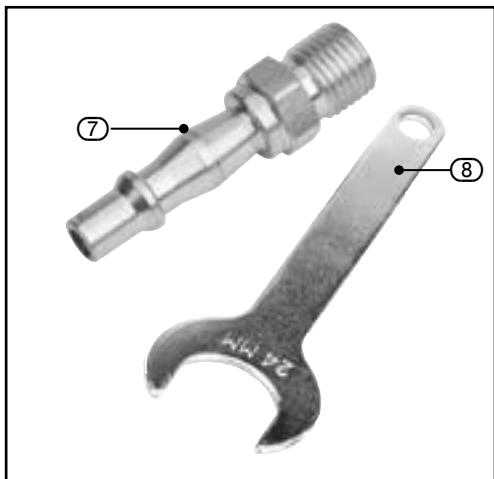

⑦ Airline coupling screw adaptor.

⑧ 24mm spanner.

**Note:** For details of our full range of accessories and consumables, please visit [drapertools.com](http://drapertools.com)

## 8. AIR SUPPLY

### 8.1 AIR TOOL OIL SPECIFICATION

Failure to follow these instructions will lead to premature malfunction of the equipment which is not covered by the guarantee.

Air tool oil viscosity refers to its properties to flow and how it reacts with heat. A low viscosity is thinner than a high viscosity.

Air tool oil becomes thinner as it heats so choosing the right viscosity is essential. If the viscosity is too low it may provide insufficient lubrication when heated. Equally, if it is too high, the fluid may provide excessive resistance to move through the lines when cold.

The ISO (International Standards Organisation) viscosity grading system measures the kinematic viscosity in centistokes (cSt) at 40° which is today's accepted standard. The SAE (Society of Automotive Engineers) viscosity grade value is based on a scale.

This equipment is suited to an ISO grade 22 – 32 (SAE grade 5W – 15W) monograde oil.

The oil must be constantly supplied to the equipment during use to ensure complete lubrication and optimum performance is achieved. It also acts as a rust inhibitor when the equipment is not in use. We recommend the use of Draper Air Tool Oil.

This air tool operates at a maximum pressure of 90psi and must be controlled via a combination pressure regulator, in-line lubricator and moisture filter such as the Draper range (see you local Draper stockist) which with proper maintenance will ensure a constant supply of dry air and lubricating oil at all times (see illustration below). Always check machine operating pressure before use.

Water in the compressor tank will cause serious corrosion to your air tools and should be drained daily to avoid excessive water in your air supply. Dirty wet air rapidly shortens the life of your air tool.

If you are using an air tool on a hose over 25ft long it is advisable to increase the bore of the hose to the next larger size available, i.e., 1/4" increases 3/8". This will ensure adequate pressure and volume of air to power the machine.

### 8.2 RECOMMENDED AIR SUPPLY SET UP – FIG. 1

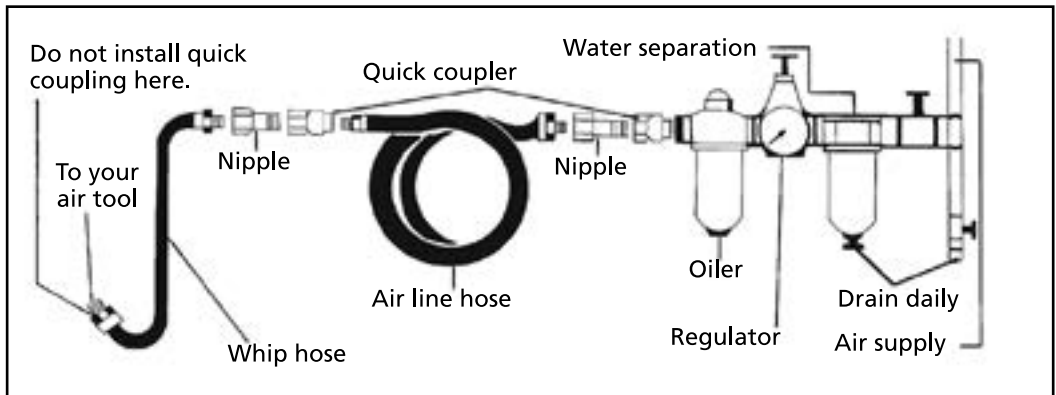

FIG.1

After each use and before prolonged storage, lubricate the equipment with approximately 1.5ml of air tool oil directly down the air inlet.

## 9. ASSEMBLY

### 9.1 CONNECTION TO THE AIR SUPPLY – FIG.2

#### Whip hose:

To connect the air sander to an air line, a ¼”BSP male thread whip hose will be required. The connection must be tight for an airtight union.

### 9.2 ATTACHING THE HOOK & LOOP SHEETS – FIG.3

**Note:** Disconnect the air supply prior to carrying out maintenance, servicing or adjustment.

This sander is equipped to accept hook & loop type sanding sheets. Simply align the edges of the sanding sheet with the backing pad and press together firmly.

If the pad is a non punched type use a suitable tool to pierce the sheet in the appropriate areas. This will aid with dust removal, reducing the hazard.

### 9.3 DUST COLLECTION – FIG.4

The sander is not supplied with a dust extraction hose (3.1). To connect a dust extraction hose, insert into (3.1) the dust outlet port (3) firmly. Attach the other end of hose to a suitable vacuum dust extractor.

**Note:** Always wear a protective dust mask in addition to these measures.



FIG.2



FIG.3

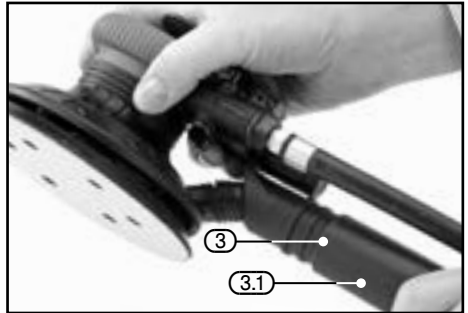

FIG.4

# 10. OPERATION AND USE

## 10.1 OPERATION & AIR REGULATION

### – FIG.5

- To start the sander press down trigger (1), and release again to slow down/stop the pad.
- To alter the amount of air being fed into the sander, varying the speed, turn lever (4) during operation. Adjust accordingly.

If the pad is a non punched type use a suitable tool to pierce the sheet in the appropriate areas. This will aid with dust removal, reducing the hazard.

## 10.2 REPLACING THE BACKING PAD

### – FIGS.6 – 7

With the air supply disconnected, lift up the edge of shroud (6) to access the orbital mechanism.

- Insert spanner (8) and locate onto the flats on the side of the spindle. Hold the spanner while rotating the pad (5) to remove.
- When assembling do not over tighten the backing pad.

**Note:** Always ensure the spanner has been removed before restarting the sander as the result will cause damage or injury.

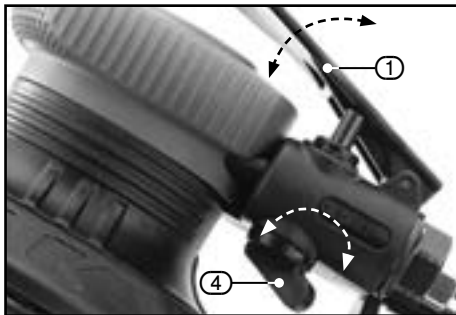

FIG.5

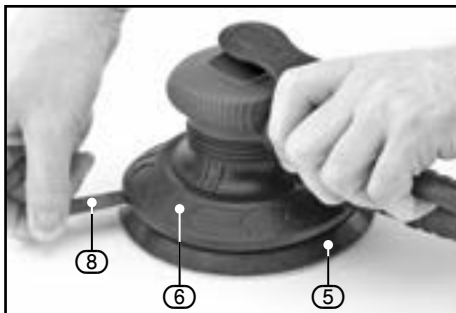

FIG.6



FIG.7

# 11. MAINTENANCE AND TROUBLESHOOTING

## 11.1 EVERY-DAY MAINTENANCE CHECKS

Before connection to the air supply:

- Drain the compressor reservoir of condensate.
- Drain the air lines of condensate.
- Drain the combined separator filter, regulator, water trap.
- Fill up the combined separator filter, regulator, lubricant reservoir.
- Check the line pressure is correct for the tool.

## 11.2 AFTER USE MAINTENANCE CHECKS

- Repeat the above procedures.
- Lubricate the tool with approximately 1.5ml of oil directly down the air inlet.

## 11.3 TROUBLESHOOTING GUIDE

Problem	Possible Cause	Remedy
Tool will not operate. Air flows slightly from exhaust. Spindle turns freely.	Motor or throttle seized with dirt.	Check for dirt in air inlet.
		Pour air tool lubricating oil into air inlet.
		Operate trigger in short bursts.
		Disconnect air line supply, then turn drill chuck by hand. Reconnect air supply.
		If motor fails to turn, return to service centre.
Tool runs slowly. Air flows freely from exhaust.	Rotor vane seized.	Pour air tool lubricating oil into air inlet.
		Operate trigger in short bursts.
		Tap motor housing gently with plastic mallet.
		If still not functional, return tool to service centre.
Spindle seized.	Motor vane broken.	Return to service centre.
Tool will not shut off.	'O' rings throttle valve dislodged from seat inlet valve.	Replace 'O' ring or return to service centre.

We recommend the use of Draper Air Tool Oil:

# 12. DISPOSAL

---

## 12.1 DISPOSAL

- At the end of the machine's working life, or when it can no longer be repaired, ensure that it is disposed of according to national regulations.
- Contact your local authority for details of collection schemes in your area.

# 13. EXPLANATION OF SYMBOLS

---

## 13.1 EXPLANATION OF SYMBOLS



Read the instruction manual.



Wear face mask and safety glasses.



Wear ear defenders.



Wear protective gloves.



Do not abandon into the environment.



Keep out of the reach of children.



**Warning!**



Continuous A-Weighted Sound Pressure Level.



Rotational direction.

# CONTACTS

Draper Tools Limited, Hursley Road,  
Chandler's Ford, Eastleigh, Hampshire. SO53 1YF. U.K.

Help Line: (023) 8049 4344

Sales Desk: (023) 8049 4333

Internet: [drapertools.com](http://drapertools.com)

E-mail: [sales@drapertools.com](mailto:sales@drapertools.com)

General Enquiries: (023) 8026 6355

**Service/Warranty Repair Agent:**

For aftersales servicing or warranty repairs, please contact the Draper Tools Help Line for details of an agent in your local area.

## YOUR DRAPER STOCKIST

DBCH0720

©Published by Draper Tools Limited.

No part of this publication may be reproduced, stored in a retrieval system or transmitted in any form or by any means, electronic, mechanical photocopying, recording or otherwise without prior permission in writing from Draper Tools Ltd.