



# **MaxiCharger AC Lite (10 kW)**

---

## **Installation and Operation Manual**

Version 2.0

**UL Model**

## **Trademarks**

Autel® and MaxiCharger® are trademarks of Autel Intelligent Technology Corp., Ltd., registered in China, the United States and other countries. All other marks are trademarks or registered trademarks of their respective holders.

## **Copyright Information**

No part of this manual may be reproduced, stored in a retrieval system or transmitted, in any form or by any means, electronic, mechanical, photocopying, recording, or otherwise without the prior written permission of Autel.

## **Disclaimer of Warranties and Limitation of Liabilities**

All information, specifications and illustrations in this manual are based on the latest information available at the time of printing.

Autel reserves the right to make changes at any time without notice. While information of this manual has been carefully checked for accuracy, no guarantee is given for the completeness and correctness of the contents, including but not limited to the product specifications, functions, and illustrations.

Autel will not be liable for any direct, special, incidental, indirect damages or any economic consequential damages (including the loss of profits).

**For Services and Support (24/7):**

**Web:** [www.autelenergy.us](http://www.autelenergy.us)

**Tel:** (844) 765-0150

**Email:** [evsupport@autel.com](mailto:evsupport@autel.com)

**Address:** 36 Harbor Park Drive, Port Washington, New York, USA  
11050

For technical assistance in all other markets, please contact your local selling agent.

# Safety

Safety messages are provided to help prevent personal injury and equipment damage. All safety messages are introduced by a single word indicating the hazard level.

## **DANGER**

Indicates an imminently hazardous situation with a high risk level which, if the danger is not avoided, will cause death or serious injury.

## **WARNING**

Indicates a potentially hazardous situation with moderate risk level which, if the warning is not obeyed, can cause death or serious injury.

## **CAUTION**

Indicates a potentially hazardous situation with a medium risk level which, if the caution is not obeyed, may cause minor or moderate injury or damage to the equipment.

The safety messages herein cover situations Autel is aware of. Autel cannot know, evaluate or advise you as to all of the possible hazards. You must be certain that any condition or service procedure encountered does not jeopardize your personal safety.

- Read and follow all warnings and instructions before installing and operating the charger.
- This charger should only be installed by a licensed electrician in accordance with all local codes and ordinances.
- This charger must be grounded through a permanent wiring system or an equipment-grounding conductor.
- Do not install or use this charger near flammable, explosive, harsh, or combustible materials, chemicals or vapors.
- Children should be supervised when around this charger.
- Do not insert fingers or foreign objects into the electric vehicle connector.
- Do not use the charger if the flexible power cord or EV cable is frayed, broken or otherwise damaged, or fails to operate.
- Do not use the charger if the enclosure or the EV connector is frayed, broken or otherwise damaged, or fails to operate.
- Use 90 °C wire copper conductors only.
- Do not operate the charger outside its operating temperature range of -40 to 131 °F (-40 to 55 °C).
- Incorrect installation and testing of the charger could potentially damage the vehicle's battery, components, and/or the charger itself.

- Handle the charger with care during transportation. Do not subject it to strong force or impact or pull, twist, tangle, drag or step on the equipment, to prevent damage to it or any components.
- For NEMA plug-in version, use only the 14-50 NEMA outlet.
- Neutral must be bonded to Ground upstream at the transformer or panel for each separately derived system.

# CONTENTS

<b>1</b>	<b>Using This Manual</b>	<b>1</b>
	1.1 Conventions	1
	1.2 Revision History	2
<b>2</b>	<b>General Introduction</b>	<b>3</b>
	2.1 Product Overview	4
	2.2 In the Box	6
	2.3 Recommended Tools	7
<b>3</b>	<b>Installation</b>	<b>8</b>
	3.1 Electrical Design	8
	3.2 Preparing for Installation	11
	3.3 NEMA Plug-in Outlet	13
	3.4 Installing the Charger	14
	3.5 Adjusting the Rated Current	17
	3.6 Finishing Installation	18
<b>4</b>	<b>Operation</b>	<b>19</b>
	4.1 Powering On	19
	4.2 Adding the Charger	20
	4.3 Start Charging	21
	4.4 Stop Charging	22

<b>5</b>	<b>Troubleshooting</b>	<b>23</b>
<b>6</b>	<b>Specifications</b>	<b>26</b>
	6.1 Specifications	26
	6.2 Product Dimensions	28
<b>7</b>	<b>Compliance</b>	<b>29</b>

# 1 Using This Manual

This manual describes the installation and use of the MaxiCharger AC Lite 10 kW. Prior to installation, read through this manual to be familiarized with the instructions of this charger to ensure a successful installation and smooth operations.

## 1.1 Conventions

The following conventions are used:

### **BOLD TEXT**

Bold text is used to highlight selectable items such as buttons and menu options.

### **NOTE**

A NOTE provides helpful information such as additional explanations, tips, and comments.

## **IMPORTANT**

IMPORTANT indicates a situation which, if not avoided, may result in damage to the test equipment or vehicle.

## **ILLUSTRATION**

Illustrations used in this manual are only examples; the actual product(s) or screens may vary.

## **1.2 Revision History**

<b>Version</b>	<b>Date</b>	<b>Description</b>
V1	2022.10	Initial version
V2	2024.02	Complete manual overhaul

# 2 General Introduction

The MaxiCharger AC Lite 10 kW is designed to charge a plug-in hybrid electric vehicle or an electric vehicle (hereinafter called EV) at your home or condo. Our chargers provide you with safe, reliable, fast, and smart charging solutions.

This manual will instruct you how to install and use this charger.

## **Intended Use**

This charger is intended for the AC charging of EVs. It is intended for both indoor and outdoor use.

## **DANGER**

- If you use the charger in any way other than described in this manual or other related documents, possible death, injury and damage to property can occur.
- Use the charger only as intended.

# 2.1 Product Overview

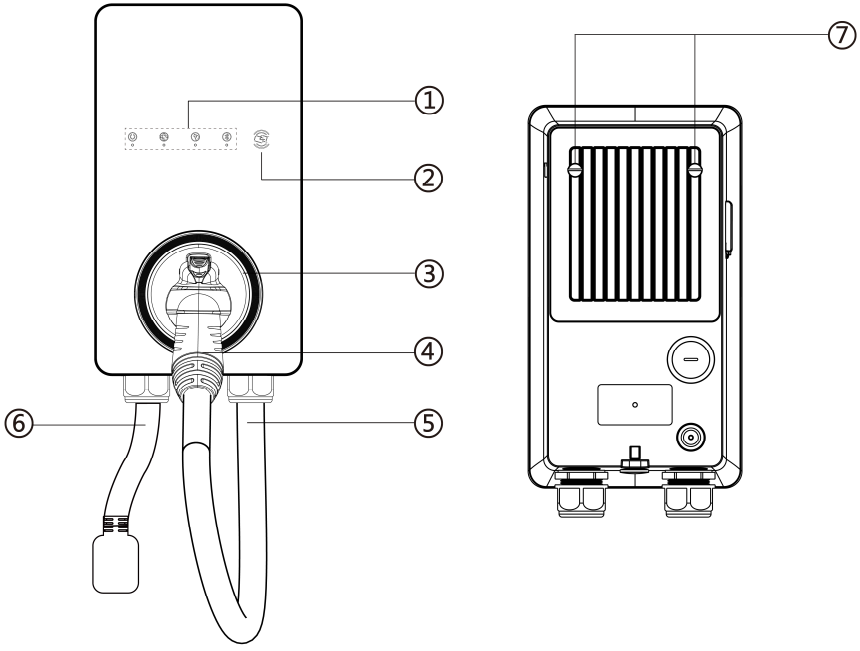

- 1.** LED Indicators (from left to right):
  - Power LED
  - Internet Connection LED
  - Charging LED
  - Bluetooth Connection LED
- 2.** RFID Reader
- 3.** Holster
- 4.** Connector
- 5.** EV Charging Cable
- 6.** NEMA Cable
- 7.** Mounting Screws

## LED Description

LED	Description
<b>Power LED</b>	<p><b>Solid Green:</b> The charger is on.</p> <p><b>Not Illuminated:</b> The charger is off.</p> <p><b>Flashing Yellow:</b> Data is being transmitted and/or firmware is upgrading.</p> <p><b>Solid Yellow:</b> Firmware upgrade has failed.</p> <p><b>Solid Blue:</b> Data transmission has failed; will illuminate green in five seconds.</p>
<b>Internet Connection LED</b>	<p><b>Solid Green:</b> The charger is connected to the Internet.</p> <p><b>Not Illuminated:</b> The charger is not connected to the Internet.</p> <p><b>Flashing Green:</b> The charger has joined a DLB (Dynamic Load Balancing) network.</p>
<b>Charging LED</b>	<p><b>Solid Blue:</b> An EV is connected.</p> <p><b>Flashing Blue:</b> A schedule is active.</p> <p><b>Flashing Green:</b> An EV is charging.</p> <p><b>Solid Green:</b> A charge session has ended.</p> <p><b>Not Illuminated:</b> The charger is not connected.</p> <p><b>Solid Yellow:</b> A recoverable error has occurred or it is temporarily disabled by the server.</p> <p><b>Solid Red:</b> An irrecoverable error has occurred. (Please contact support.)</p>
<b>Bluetooth Connection LED</b>	<p><b>Flashing Green:</b> The charger is connected to a mobile device via Bluetooth.</p> <p><b>Not Illuminated:</b> The charger is not connected via Bluetooth.</p>

## 2.2 In the Box

Ensure that all parts are delivered according to the order. Check the packages for the following parts.

Charger  
1 PC

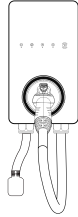

Wall Dock  
1 PC



Screw  
(M6 x 50)  
2 PCS



Screw  
(M5 x 12)  
1 PC



Wall Anchor  
(5/16")  
2 PCS

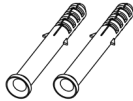

Bottom Entry  
Power Conduit  
Plug (M32)  
1 PC

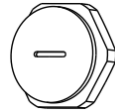

Quick  
Reference  
Guide  
1 PC



Packing List  
1 PC













T25 Torx  
Screwdriver  
1 PC



T10 Torx  
Screwdriver  
1 PC



## 2.3 Recommended Tools

Wall stud finder		Pencil	
PH2 screwdriver		Spirit level	
Power drill		5/16" drill bit	
Flathead screwdriver		Multimeter	
Tape measure		Brush	
3/4" conduit fitting			

**NOTE**  
The tools mentioned above are not included in the package. Ensure they are readily available prior to installation.

# 3 Installation

## 3.1 Electrical Design

### 3.1.1 Upstream Wiring

Chargers are considered continuous load devices (EVs draw maximum load for long durations); therefore, electrical branch circuits must be sized at 125% of the load for North American installations, in accordance with National Electric Code (NEC) requirements. (For other regions, refer to local code.) This means that for a maximum 40 A load at 208/240 V output to an electric vehicle, 50 A breaker is required.

Wiring must be sized in accordance with NEC code for continuous load devices. Typically, 6 AWG or 8 AWG (16 mm<sup>2</sup> or 10 mm<sup>2</sup>) insulated electrical wire is used, depending upon the rating of the circuit and the distance between the electrical panel and the charger. The terminal block accepts a maximum of 6 AWG (16 mm<sup>2</sup>).

## 240 VAC Panel

1. Main Breaker
2. PE Bus
3. L1
4. L2
5. Local Service or Sub Panel
6. L1
7. L2
8. PE
9. Input Terminal Block
10. Output Terminal Block

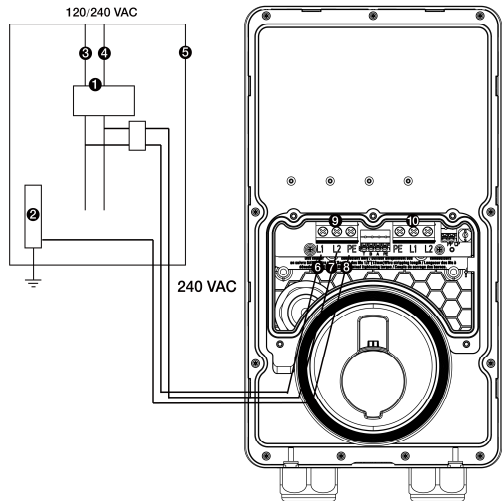

## 208 VAC Panel

1. Main Breaker
2. PE Bus
3. L1
4. L2
5. L3
6. Local Service or Sub Panel
7. L1
8. L2
9. PE
10. Input Terminal Block
11. Output Terminal Block

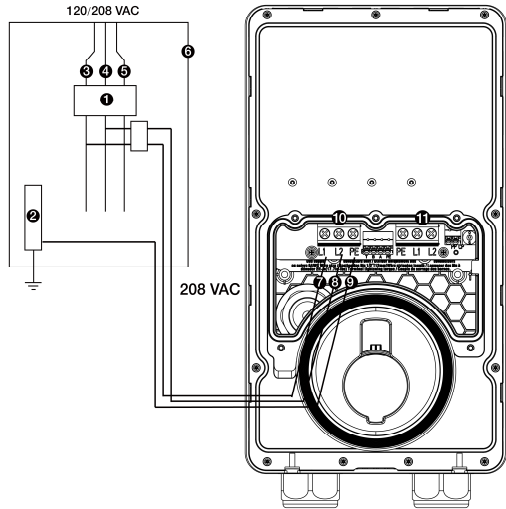

### 3.1.2 Grounding Requirements

The charger must be connected to a grounded, metal, and permanent wiring system. An equipment-grounding conductor must be run with circuit conductors and connected to an equipment-grounding terminal or lead on the charger.

A grounding conductor that complies with applicable codes must be grounded to earth at the service equipment or, when supplied by a separate system, at the supply transformer.

Neutral is not used to power the charger but must be properly connected to ground, at the panel transformer, to provide necessary voltage reference relative to ground.

## 3.2 Preparing for Installation

- Install the charger on a flat and vertical surface capable of supporting its weight (e.g., a finished wall or pedestal). The weight of the MaxiCharger AC Lite 10 kW is approximately 15.9 lbs. (7.2 kg).
- Install the charger in a location that allows the charging cable to remain within its bending tolerance.
- Position the charger in a location where it is not vulnerable to being damaged.
- Ensure the electrical panel supports a 240 V dedicated circuit with a new, dedicated, and non-GFCI two-pole circuit breaker, in accordance with local codes and ordinances.

- The recommended installation height for the charger is as shown. The minimum outdoor installation height is 24 inches (600 mm) and that of indoor is 18 inches (450 mm).

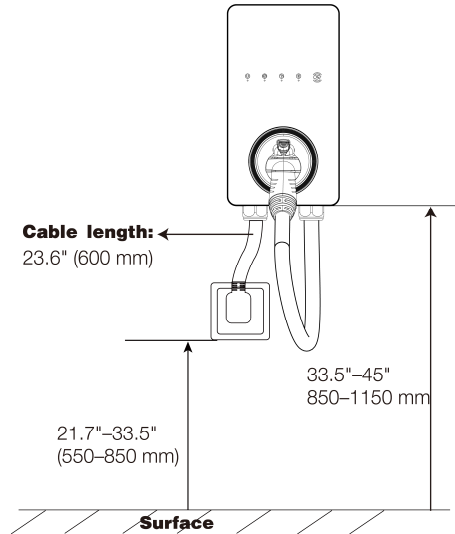

- The NEMA plug-in installation requires an outdoor-rated and weather-resistant electrical outlet.

## CAUTION

A supplement surge protection breaker must be installed at the service panel if the installation area experiences frequent thunderstorms.

## 3.3 NEMA Plug-in Outlet

This section introduces how to install a NEMA outlet if you do not have one already.

### WARNING

Switch off the circuit breaker of the electrical outlet before installing the device.

- If you already have a NEMA outlet, ensure that it complies with local electrical codes and has a designated circuit breaker and electrical wiring that are dimensioned appropriately.
- Ensure you have the correct permits for this electrical installation.
- The NEMA outlet must be placed on the left side of the charger.

- When installing the outlet, ensure the ground pin is facing up as shown.

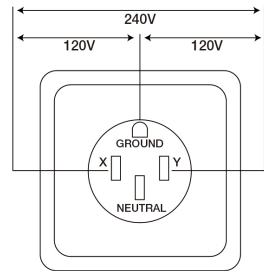

### CAUTION

To reduce the risk of fire, connect only to a circuit with a branch circuit over-current protection of 50 A in accordance with ANSI/NFPA 70 (US) CSA C22.1 (Canada) the equipment.

## 3.4 Installing the Charger

### **DANGER**

Risk of shock. Turn off the power to the outlet at the circuit breaker until the installation is completed.

### **STEP 1**

To find the ideal mounting height of the charger:

1. Find the wall stud nearest to the NEMA outlet using a wall stud finder. Draw a vertical line of approximately 20" (50 cm) in line with the wall stud.

Alternatively, you may find a suitable location on a solid wall.

2. Plug the NEMA cable into the outlet, and position the charger centered on the vertical line. Ensure that the NEMA cable has a slight curve and is not stretched.
3. Mark a horizontal line at the bottom of the charger.
4. Unplug the charger.

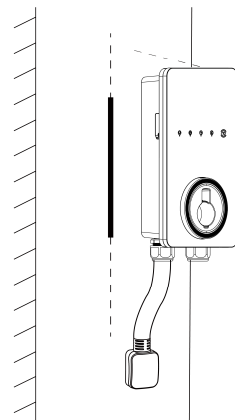

## STEP 2

Place the wall dock with the bottom edge aligned with the horizontal line and the center holes aligned with the vertical line. Mark the two lower mounting holes (A) and remove the wall dock.

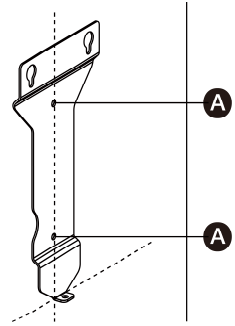

## STEP 3

**1.** Drill two 5/16" holes and insert two 5/16" diameter wall anchors into the holes.

**2.** Attach the wall dock to the mounting location by inserting two M6 x 50 screws (B) into the lower mounting holes. Tighten the screws using a PH2 screwdriver.

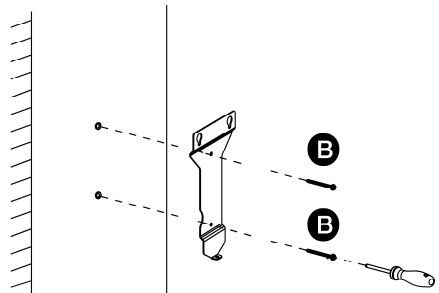

## STEP 4

Attach the charger to the wall dock by inserting the mounting screws (D) on the back of the charger into the two upper mounting holes (C). Slide the charger downwards to engage the screws.

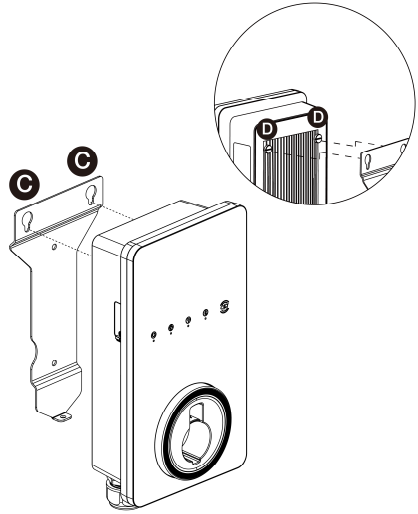

## STEP 5

Screw the M5 x 12 screw (E) into the hole at the bottom of the charger and tighten the screw to secure the charger using the T25 Torx screwdriver.

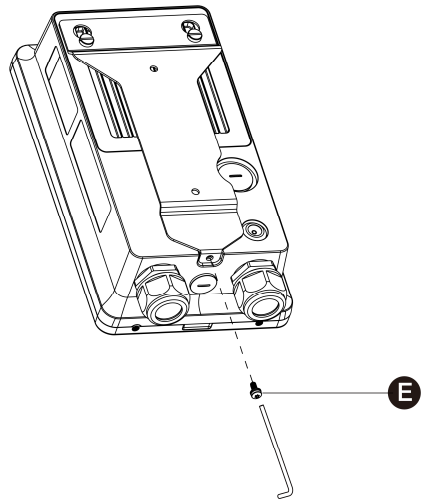

## 3.5 Adjusting the Rated Current

The MaxiCharger AC Lite 10 kW allows you to manually set a lower maximum current using the built-in current selector when installing the charger on a circuit rated lower than the maximum rating for the charger.

### STEP 1

Remove the screws using the T10 Torx screwdriver and remove the covers from the charger.

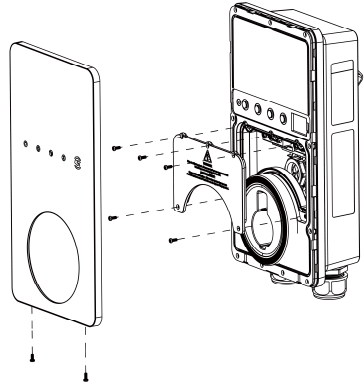

### STEP 2

Locate the current selector. Then use a flathead screwdriver to set the rotary switch to the appropriate position per the table below.

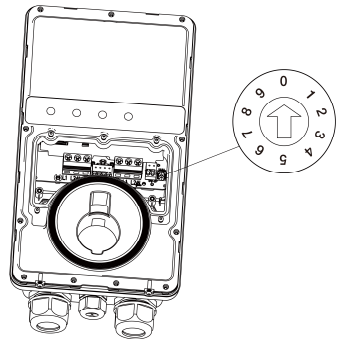

### CAUTION

To reduce the risk of fire, only connect the charger to a circuit with a branch circuit over-current protection of 125% of the selected maximum amperage setting of the device in accordance with ANSI/NFPA 70 (US) CSA C22.1 (Canada).

Position	Amperage (A)	Circuit Breaker Rating
0	Not in Use	N/A
1	16	20
2	24	30
3	32	40
4	40	50
5	48	60
6	50	70
7	Not in Use	N/A
8	Not in Use	N/A
9	Not in Use	N/A

### NOTE

- When the rotary switch is at 0, 7, 8 or 9, the corresponding amperage will still be 16, 50, 50, and 50A, respectively.
- The maximum current is limited by the power rating of a charger. For this charger, the maximum current is 40A.

## 3.6 Finishing Installation

1. Reinstall the covers and tighten the screws.
2. Plug the NEMA cable into the NEMA outlet.

# 4 Operation

## 4.1 Powering On

Once all electrical connections have been safely made, switch on the power to the circuit from the circuit breaker and wait for the power supply to come on. There will be a series of self-check starts, making sure that the charger works correctly and safely. The power LED should illuminate green.

### **WARNING**

Be careful when working with electricity.

## 4.2 Adding the Charger

1. Scan the QR code below to download the Autel Charge app to your mobile device from the Google Play or App Store. For iOS users, you will be redirected to the App Store; for Android users, you will be redirected to the Google Play.



2. Open the Autel Charge app on your mobile device, and log in with your phone number or email. If you do not yet have an account, register with your phone number first.
3. Scan the QR code or enter the serial number and PIN code, which can all be found on the Quick Reference Guide, to add the charger.
4. Follow the on-screen instructions to connect your charger via Bluetooth and connect it to the Internet. Then choose a desired function to start.

## 4.3 Start Charging

1. Remove the connector from the holster.
2. Plug the connector into the EV charging port.
3. Choose one of the following ways to start a charge session:
  - If the Auto Start function is enabled in the Autel Charge app, the charger will automatically start charging once the connector is properly connected.
  - Use the Autel Charge app by tapping **Start** on the Charge screen.
  - If you have set a charging schedule in the Autel Charge app, the charger will initiate a charge session automatically as scheduled.
  - If the RFID function is enabled, tap your RFID card on the RFID reader.

### NOTE

Ensure the EV is charging. The charging LED on the charger should be flashing green. If you suspect the vehicle is not charging properly, try reconnecting the connector or contact Autel technical support.

## 4.4 Stop Charging

### NOTE

- If the connector is unplugged from the EV during a charge session, the charger automatically disconnects the power supply. This stops all charging operations.
- When the vehicle is fully charged, the charger will automatically disconnect the power supply.

1. To stop charging, choose either of the following two ways:
  - Wait for the charge session to end and no further actions are required in the case of scheduled charging or Auto Start.
    - The charging LED will illuminate solid green.
    - The Autel Charge app displays that the EV is fully charged.
  - Tapping **Stop** on the Charge screen. Or, if the RFID function is enabled, tap the RFID card on the RFID reader again.
2. Unplug the connector from the EV and return it to the holster.

# 5 Troubleshooting

Item	Problems	Solutions
1	The charger is successfully added, but the Bluetooth connection fails.	Check whether the QR code on the charger is consistent with the QR code on the Quick Reference Guide. If so, make sure the Bluetooth is enabled on your mobile device; if not, contact customer support.
2	The charge session does not start as scheduled.	Do not insert the connector into your EV charging port before setting up a charging schedule for the first time. Insert the EV charging cable after the schedule is set up.
3	Over-voltage	Use the multimeter to check whether the voltage on the power input is too high. If the result is greater than or equal to 115 % of the rated voltage (276 V), contact local power grid company.

4	Under-voltage	Use the multimeter to check whether the voltage on the power input is not sufficient. If the result is less than or equal to 70 % of the rated voltage (161 V), contact local power grid company.
5	Ground fault	Ensure the charger is grounded correctly.
6	Power failure	Ensure the switch to the circuit breaker is on.
7	Over-heating	<ul style="list-style-type: none"> <li data-bbox="605 683 972 791">➤ Check whether the EV charging cable is securely connected.</li> <li data-bbox="605 815 972 967">➤ Ensure the operating temperature is within the specified range on the product label.</li> <li data-bbox="605 991 972 1142">➤ Stop charging. Restart charging until it is within the operation temperature range.</li> </ul>
8	Residual current detected	Unplug the vehicle and plug in again. If the problem persists, contact customer support.

9	Bluetooth communication failure	<ul style="list-style-type: none"> <li>➤ Ensure the Bluetooth is enabled on your mobile device and the charger is powered on and operating properly.</li> <li>➤ Forget the charger in the Bluetooth settings on your mobile device and pair the charger to your device via Bluetooth again.</li> <li>➤ If the problem persists, contact customer support.</li> </ul>
10	Update failure via Bluetooth	<ul style="list-style-type: none"> <li>➤ Make sure the charger is in idle status.</li> <li>➤ Make sure the Bluetooth connection is working properly.</li> <li>➤ If the problem persists, contact customer support.</li> </ul>
11	Internet connection fails	<ul style="list-style-type: none"> <li>➤ Try to connect another device to the same Internet, verifying the Internet connection is working properly.</li> <li>➤ If the problem persists, contact customer support.</li> </ul>

# 6 Specifications

## 6.1 Specifications

Item	Description
AC Power Output Rating	Maximum 10 kW (240 VAC @ 40 A)
AC Power Input Rating	208/240 VAC, 60 Hz, single phase @ 16 A, 24 A, 32 A, 40 A, 48 A, 50 A
Circuit Breaker Options	20 A, 30 A, 40 A, 50 A, 60 A, 70 A (must be sized at 125% of the maximum load, e.g., 50 A breaker for 40 A output)
Input Wiring Scheme	Three wires: L1, L2, and Earth (no neutral)
Input Cord	NEMA 16-50P Cable length: 23.6" (600 mm)
Connector Type	SAE J1772
Charging Cable Length	25 ft. (7.5 m)
Display	4 LEDs
Metering	Meter IC, $\pm 1\%$
Ground Fault Detection	20 mA CCID with auto retry

<b>Protection</b>	Overcurrent, overvoltage, undervoltage, integrated surge protection
<b>Connectivity</b>	Bluetooth Wi-Fi (2.4G, 802.11 b/g/n)
<b>Card Reader</b>	ISO 15693, ISO 14443
<b>Communication Protocols</b>	OCPP 1.6J
<b>Mounting</b>	Wall-mounted or floor using a pedestal
<b>Enclosure Ratings</b>	NEMA 4X, indoor or outdoor installation
<b>Humidity</b>	< 95%, non-condensing
<b>Operating Altitude</b>	6561.68 feet (2000 m)
<b>Operating Temperature</b>	-40 to 131 °F (-40 to + 55 °C)
<b>Storage Temperature</b>	-40 to 158 °F (-40 to + 70 °C)
<b>Dimension (H x W x D)</b>	13.2" x 7.4" x 3.8" (336 x 187 x 97 mm)
<b>Weight</b>	Approximately 15.9 lbs. (7.2 kg)

NEC Article 625 and UL 916, UL 2594, UL2231-1, UL2231-2, UL 1998, CSA C22.1

### Safety and Compliance

Automatic reset feature is provided.

### AVERTISSEMENT

Caractéristique de réarmement automatique incluse.

---

### Codes and Standards

FCC Part 15 Class B, Energy Star, OpenADR2.0 B

---

### Warranty

3 years

---

## 6.2 Product Dimensions

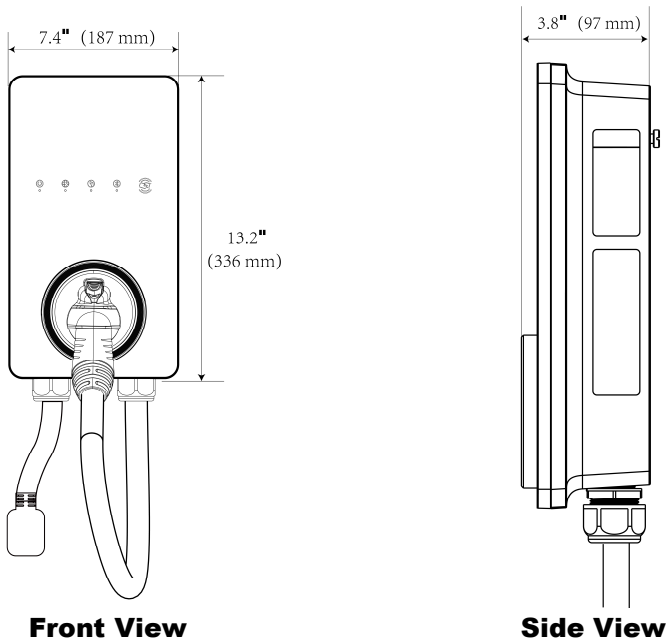

# 7 Compliance

## FCC regulatory conformance:

This device complies with Part 15 of the FCC Rules. Operation is subject to the following two conditions:

- (1) This device may not cause harmful interference.
- (2) This device must accept any interference received, including interference that may cause undesired operation.

**NOTE:** This equipment has been tested and found to comply with the limits for a Class B digital device, pursuant to part 15 of the FCC Rules. These limits are designed to provide reasonable protection against harmful interference in a residential installation.

This equipment generates uses and can radiate radio frequency energy and, if not installed and used in accordance with the instructions, may cause harmful interference to radio communications. However, there is no guarantee that interference will not occur in a particular installation. If this equipment does cause harmful interference to radio or television reception, which can be determined by turning the equipment off and on, the user is encouraged to try to correct the interference by one or more of the following measures:

- Reorient or relocate the receiving antenna.
- Increase the separation between the equipment and receiver.
- Connect the equipment into an outlet on a circuit different from that to which the receiver is connected.
- Consult the dealer or an experienced radio/TV technician for help

**NOTE:** The manufacturer is not responsible for any radio or TV interference caused by unauthorized modifications to this equipment. Such modifications could void the user's authority to operate the equipment.

## **RF Exposure**

This equipment complies with FCC radiation exposure limits set forth for an uncontrolled environment. This equipment should be installed and operated with minimum distance of 20 cm between the radiator and your body. This transmitter must not be co-located or operating in conjunction with any other antenna or transmitter.

## **IC regulatory conformance:**

This device complies with CAN ICES-3 (B)/NMB-3(B).

This device contains licence-exempt transmitter(s)/receiver(s) that comply with Innovation, Science and Economic Development Canada's licence-exempt RSS(s). Operation is subject to the following two conditions:

- (1) This device may not cause interference.
- (2) This device must accept any interference, including interference that may cause undesired operation of the device.

Cet appareil est conforme à la norme CAN ICES-3 (B)/NMB-3 (B).

Cet appareil contient des émetteurs / récepteurs exempt (s) de licence qui sont conformes aux RSS exemptes de licence d'Innovation, Sciences et Développement économique Canada. Son fonctionnement est soumis aux deux conditions suivantes:

- (1) Cet appareil ne doit pas provoquer d'interférences.
- (2) Cet appareil doit accepter toute interférence, y compris les interférences susceptibles de provoquer un fonctionnement indésirable de l'appareil.

## **RF Exposure**

This equipment complies with IC radiation exposure limits set forth for an uncontrolled environment. This equipment should be installed and operated with minimum distance of 20 cm between the radiator and your body. This transmitter must not be co-located or operating in conjunction with any other antenna or transmitter.

Cet équipement est conforme aux limites d' exposition aux rayonnements de la IC établies pour un environnement non contrôlé. Cet équipement doit être installé et fonctionner à au moins 20cm de distance d'un radiateur ou de votre corps.

**AUTEL<sup>®</sup>**

**[www.autelenergy.com](http://www.autelenergy.com)**