

Portable MiniDisc Player

Operating Instructions

Player Operation _____ **page 11**

Software Operation _____ **page 32**



NetMD



MDLP

"WALKMAN" is a registered trademark of Sony Corporation to represent Headphone Stereo products.  is a trademark of Sony Corporation.

MZ-N420D

© 2004 Sony Corporation

WARNING

To prevent fire or shock hazard, do not expose the unit to rain or moisture.

Do not install the appliance in a confined space, such as a bookcase or built-in cabinet.

To prevent fire, do not cover the ventilation of the apparatus with news papers, table cloths, curtains, etc. And don't place lighted candles on the apparatus.

To prevent fire or shock hazard, do not place objects filled with liquids, such as vases, on the apparatus.

Certain countries may regulate disposal of the battery used to power this product. Please consult with your local authority.

Caution

The use of optical instruments with this product will increase eye hazard.

CAUTION — CLASS 1M INVISIBLE LASER RADIATION WHEN OPEN

DO NOT VIEW DIRECTLY WITH OPTICAL INSTRUMENTS

Information

IN NO EVENT SHALL SELLER BE LIABLE FOR ANY DIRECT, INCIDENTAL OR CONSEQUENTIAL DAMAGES OF ANY NATURE, OR LOSSES OR EXPENSES RESULTING FROM ANY DEFECTIVE PRODUCT OR THE USE OF ANY PRODUCT.

For customers who purchased this product in the USA

Owner's Record

The serial number is located at the rear of the disc compartment lid and the model number is located at the top and bottom. Record the serial number in the space provided below. Refer to them whenever you call upon your Sony dealer regarding this product.

Model No. MZ-N420D

Serial No. _____

Product registration

Please register this product on line at www.sony.com/walkmanreg
<<http://www.sony.com/walkmanreg>>

Proper registration will enable us to send you periodic mailings about software upgrades, new products, services and other important announcements. Thank you.

If you have any questions about this product, contact:

- <http://www.sony.com/walkmansupport>
- **Sony Network Portable Audio Support Line**
1-(866)-456-7669
- **Sony Customer Information Services Center**
12451 Gateway Blvd. Fort Myers, FL 33913

Declaration of Conformity

Trade Name: SONY

Model No.: MZ-N420D

Responsible Party: Sony Electronics Inc.

Address: 680 Kinderkamack Road,
Oradell, NJ 07649 USA

Telephone No.: 201-930-6972

This device complies with Part 15 of the FCC Rules. Operation is subject to the following two conditions: (1) This device may not cause harmful interference, and (2) this device must accept any interference received, including interference that may cause undesired operation.

This equipment has been tested and found to comply with the limits for a Class B digital device, pursuant to Part 15 of the FCC Rules. These limits are designed to provide reasonable protection against harmful interference in a residential installation. This equipment generates, uses, and can radiate radio frequency energy and, if not installed and used in accordance with the instructions, may cause harmful interference to radio communications. However, there is no guarantee that interference will not occur in a particular installation. If this equipment does cause harmful interference to radio or television reception, which can be determined by turning the equipment off and on, the user is encouraged to try to correct the interference by one or more of the following measures:

- Reorient or relocate the receiving antenna.
- Increase the separation between the equipment and receiver.
- Connect the equipment into an outlet on a circuit different from that to which the receiver is connected.

— Consult the dealer or an experienced radio/TV technician for help.

You are cautioned that any changes or modifications not expressly approved in this manual could void your authority to operate this equipment.

Notice for users

On the supplied software

- Copyright laws prohibit reproducing the software or the manual accompanying it in whole or in part, or renting the software without the permission of the copyright holder.
- In no event will SONY be liable for any financial damage, or loss of profits, including claims made by third parties, arising out of the use of the software supplied with this player.
- In the event a problem occurs with this software as a result of defective manufacturing, SONY will replace it. However, SONY bears no other responsibility.
- The software provided with this player cannot be used with equipment other than that which is so designated.
- Please note that, due to continued efforts to improve quality, the software specifications may be changed without notice.
- Operation of this player with software other than that provided is not covered by the warranty.

On the battery

- When you replace the battery, be sure to use a new one.
- If “LoBATT” appears even once in the display, replace the battery.

Notes

- The recorded music is limited to private use only. Use of the music beyond this limit requires permission of the copyright holders.
- Sony is not responsible for music files that cannot be saved on your computer due to unsuccessful recording from a CD or from music downloading.

- SonicStage, MD Simple Burner, OpenMG, Magic Gate, MagicGate Memory Stick, Memory Stick, Net MD, ATRAC, ATRAC3, ATRAC3plus and their logos are trademarks of Sony Corporation.
- Microsoft, Windows, Windows NT and Windows Media are trademarks or registered trademarks of Microsoft Corporation in the United States and /or other countries.
- IBM and PC/AT are registered trademarks of International Business Machines Corporation.
- Macintosh is a trademark of Apple Computer, Inc. in the United States and/or other countries.
- MMX and Pentium are trademarks or registered trademarks of Intel Corporation.
- All other trademarks and registered trademarks are trademarks or registered trademarks of their respective holders.
- ™ and ® marks are omitted in this manual.

CD and music-related data from Gracenote, Inc., copyright © 2000-2003 Gracenote. Gracenote CDDDB® Client Software, copyright 2000-2003 Gracenote. This product and service may practice one or more of the following U.S. Patents: #5,987,525; #6,061,680; #6,154,773, #6,161,132, #6,230,192, #6,230,207, #6,240,459, #6,330,593 and other patents issued or pending.

Gracenote and CDDB are registered trademarks of Gracenote. The Gracenote logo and logotype, the Gracenote CDDB logo, and the “Powered by Gracenote” logo are trademarks of Gracenote.

Program © 2001, 2002, 2003, 2004 Sony Corporation

Documentation © 2004 Sony Corporation

Table of contents

Player Operations

Looking at the controls	12
-------------------------------	----

Getting started!	14
------------------------	----

Playing an MD right away!	16
---------------------------------	----

Various ways of playback	18
Selecting the play mode	18
Adjusting treble or bass (Digital Sound Preset)	19
Selecting the sound quality	19
Adjusting the sound quality	19

Using the group function	21
What is the group function?	21
Playing a track in group play	21
Selecting the play mode for group play (Group Play Mode)	22

Other Operations	23
Viewing various information	23
Starting the playback quickly (Quick Mode)	24
Protecting your hearing (AVLS)	25
Locking the controls (HOLD)	25

Additional information	26
Precautions	26
Specifications	28

Troubleshooting and explanations	29
Troubles and solutions	29
While playing	29
While using group function	30
Others	30
Explanations	31

Software Operation

What you can do with MD Simple Burner/ SonicStage	32
What you can do with MD Simple Burner	32
What you can do with SonicStage	32
Basic operational flow using an MD Walkman	33

Installing	34
Providing the required system environment	34
System requirements	34
Installing the software onto your computer	35
Connecting the MD Walkman to your computer	36

Using MD Simple Burner	37
Recording by computer operations	37
The window for recording all tracks on the CD	37
The window for recording selected tracks from an audio CD	38

Using SonicStage	39
Importing audio data	39
Transferring audio data from your computer to the MD Walkman	41
Transferring back audio data from the MD Walkman to your computer	43
Transferring from the MD Walkman back to your computer	43
Using SonicStage Help	45
To display SonicStage Help	45
Viewing how to use SonicStage Help	46
Searching for a word inside an explanation	46
Referring to SonicStage Help	47
Importing audio data to the computer	47
Listening to audio data on the computer	47
Managing and editing imported tracks	47
Backing up audio data	48
Troubleshooting	48
When you want to know	48

Other information	49
Uninstalling SonicStage/MD Simple Burner	49
On copyright protection	50
Troubleshooting	51
The software cannot be installed onto your computer	52
Using a MD Walkman connected to the computer	53
Index	54

Before using this product

This manual explains the player operations and the installation and basic use of the supplied software.

For details on the various operations, refer to the pages indicated below.

When using the player

Player Operation (pages 11 to 31)

Pages 11 to 31 in this manual explain all of the player functions.

Troubleshooting and explanations (page 29)

This section shows the troubles you may find while using the player, and their solutions.



When using the Net MD (the player) connected to your computer

Software Operation (pages 32 to 53)

Pages 32 to 53 in this manual explain the installation and basic operations of the supplied SonicStage and MD Simple Burner software.

Other information (page 49)

This section shows the troubles you may find while using the supplied software, and their solutions. It also has the list of frequently asked questions and answers.

SonicStage Ver. 2.0 Help

This is a help that you can view on your computer screen.

Refer to Help for details on the use of the software. To display the help window, see page 45.

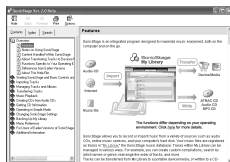

Notes on the "Software Operation" section

- The displayed items in the illustrations that appear in this section may differ from the actual items displayed by the software.
- Explanations in this section assume familiarity with basic Windows operations. For details on the use of your computer and the operating system, please refer to the respective manuals.
- Explanations in this section cover general Net MD products. For this reason, some explanations (and some illustrations) may not be applicable to your Net MD. Please refer to the operating instructions of your Net MD as well.

Checking the supplied accessories

Headphones/earphones (1)

Dedicated USB cable (1)

CD-ROM (SonicStage Ver. 2.0 and MD Simple Burner Ver. 2.0) (1)*

Recordable disc (USA and Canada models only) (1)

*Do not play a CD-ROM on an audio CD player.

Looking at the controls

This model comes in two designs with different shapes and names for the buttons.

Front of the player

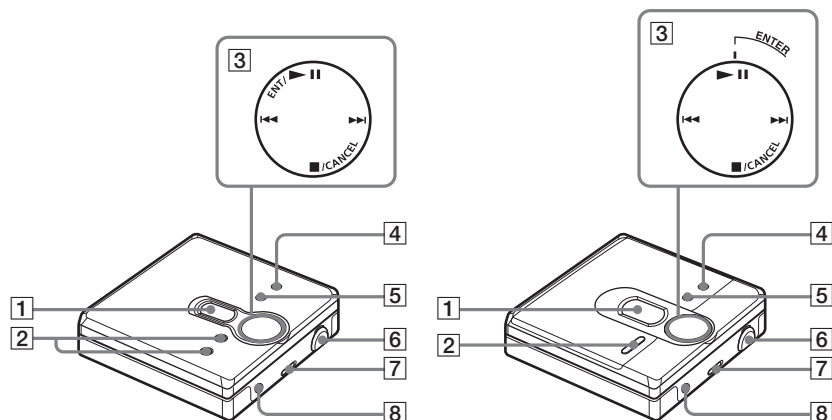

On the following pages of this manual, explanations are given using the illustration in the top-left of this page.

- 1** Display window
- 2** VOL (VOLUME) +* and – button
 - * The VOL (VOLUME) + button has a tactile dot.
- 3** 4-position control key
ENT/▶▶|| (ENTER/▶▶||)
(enter/play/pause)*
◀◀ and ▶▶ (search/AMS)
■/CANCEL (stop/cancel)
 - * The ENT/▶▶|| (ENTER/▶▶||) button has a tactile dot.
- 4** MENU button
- 5** GROUP button
- 6** USB jack
 - When connecting to your computer, connect the dedicated USB cable to this jack.
- 7** HOLD switch
- 8** ◡ (headphones/earphones) jack

Back of the player

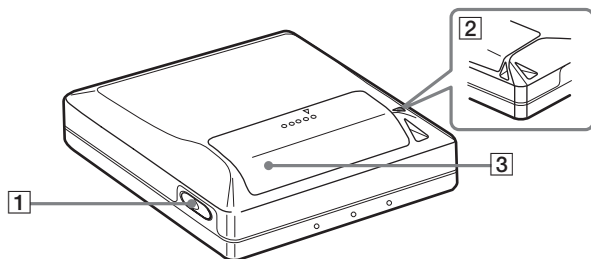

- 1** OPEN button
- 2** Hand strap hole
Use the hole to attach your own strap.
- 3** Battery compartment lid

The display window of the player

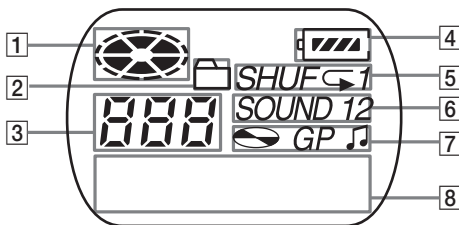

- 1** Disc indication
- 2** Group mode indication
Lights up when group mode is on.
- 3** Track number display
- 4** Battery level indication
Shows approximate battery condition.
- 5** Play mode indication
Shows play mode of the MD.
- 6** SOUND indication
- 7** Disc, group, track indication
- 8** Character information display
Displays the track names, elapsed time, etc.

Getting started!

1 Insert an alkaline dry battery.

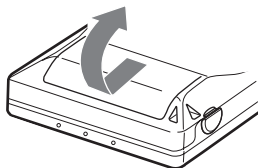

Slide to open the battery compartment lid.

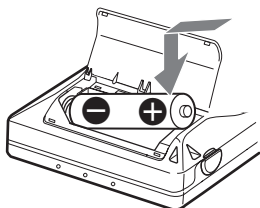

Insert one LR6 (size AA) alkaline dry battery minus end first.

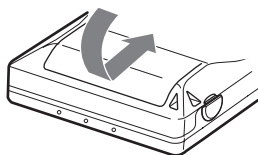

Close the lid.

When to replace the battery

You can check the battery condition through the battery indicator while using the player.



Battery power decreasing



Weak battery



The battery has gone out.

“LoBATT” flashes in the display, and the power goes off.

Battery life¹⁾

When	SP Stereo	LP2 Stereo	LP4 Stereo
playing ²⁾	Approx. 42 hours	Approx. 48 hours	Approx. 56 hours
transferring out audio data from the computer ³⁾	75 tracks (of about 5 minutes each)	300 tracks (of about 5 minutes each)	600 tracks (of about 5 minutes each)

¹⁾ When using a new Sony LR6 (size AA) alkaline dry battery (produced in Japan).

²⁾ Measured in accordance with the JEITA (Japan Electronics and Information Technology Industries Association) standard.

³⁾ The numbers of tracks that can be transferred differs according to the computer's operating environment.

Notes

- Disconnect the dedicated USB cable before replacing the dry battery.
- The battery life may be shorter than that specified, depending on the operating conditions, the temperature of the location, and varieties of batteries.
- When you replace the battery, be sure to use a new one.
- If “LoBATT” appears even once in the display, replace the battery.

2 Make connections and unlock the controls.

- 1 Connect the headphones/earphones to .

- 2 Slide HOLD in the opposite direction of the arrow indicated on the player (HOLD ) to unlock the control.

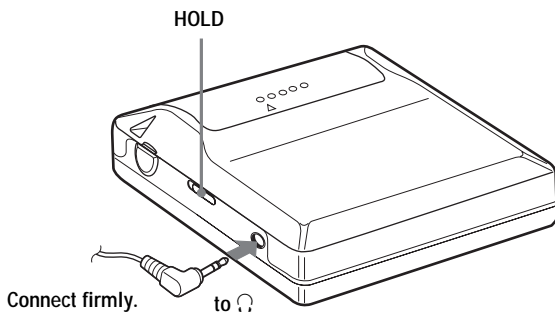

Playing an MD right away!

1 Insert an MD.

1 Press OPEN to open the lid.

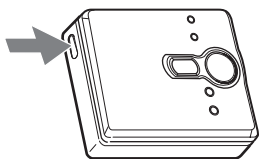

2 Insert an MD to the direction of the arrow with the label side facing front, and press the lid down to close.

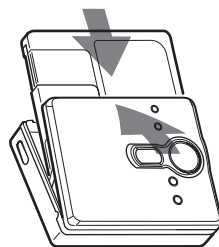

2 Play an MD.

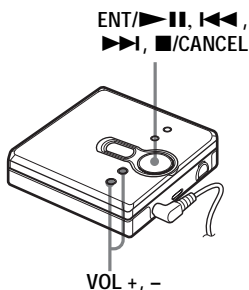

1 Press ▶||.

2 Press VOL + or - to adjust the volume.
The volume indicator appears in the display allowing you to check the volume level.

To stop play, press ■.

Playback starts from the point you last stopped playing.

To start playback from the beginning of the first track, hold down ▶|| for 2 seconds or more.

To	Operation
Pause	Press ▶▶ . Press ▶▶ again to resume play.
Find the beginning of the current track or the previous track ¹⁾	Press ◀◀◀ . Press ◀◀◀ repeatedly until the beginning of the desired track appears.
Find the beginning of the next track ²⁾	Press ▶▶▶ once.
Go backwards or forward while playing	Hold down ◀◀◀ or ▶▶▶ .
Search for a point in a track while viewing the elapsed time (Time search)	While pausing, press and hold ◀◀◀ or ▶▶▶ .
Search for a specific track while viewing track numbers (Index search)	While the player is stopped, press and hold ◀◀◀ or ▶▶▶ .
Remove the MD	Press ■ , and then press OPEN. ³⁾

¹⁾ If you press **◀◀◀** twice continuously while playing the first track of the disc, the player goes to the beginning of the last track on the disc.

²⁾ If you press **▶▶▶** during the last track of the disc, the player goes to the beginning of the first track on the disc.

³⁾ If you open the lid, the playback will begin from the beginning of the first track (except when group mode is on).

Suppressing the skip of the sound (G-PROTECTION)

The G-PROTECTION function was developed to provide a higher level of shock resistance than that of existing players in order to allow the player to be used while jogging.

Note

The playback sound may skip if:

- the player receives stronger continuous shock.
- a dirty or scratched MiniDisc is played.



- The MZ-N420D supports DSP TYPE-S for ATRAC/ATRAC3. It thus allows you to enjoy TYPE-S high-quality sound from MDs recorded in MDLP mode on TYPE-S-equipped MD decks, etc.
- The player can play the track recorded by 2 × or 4 × long playing mode (LP2 or LP4). Normal stereo playback, LP2 stereo playback, LP4 stereo playback or monaural playback is automatically selected to match the audio source.

Selecting the play mode

You can select various play modes such as normal play, single-track play (1 Trk), or shuffle play (Shuff). You can also select repeat play with the selected play mode.

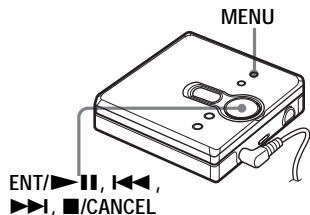

- 1 Press MENU.
- 2 Press ◀◀ or ▶▶ repeatedly until "P-MODE" appears in the display, and then press ENT/▶▶.
- 3 Press ◀◀ or ▶▶ repeatedly to select the play mode, and then press ENT/▶▶.

Each time you press ▶▶, the display item indicated by **A** changes as follows:

Pressing ENT/▶▶ while **A** is flashing causes the play mode to enter.

Pressing ▶▶ repeatedly changes **A**.

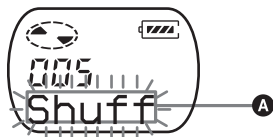

Display A ¹⁾	Play mode
Normal (normal play)	All the tracks are played once.
1 Trk (single-track play)	A single track is played once.

Display A ¹⁾	Play mode
Shuff (shuffle play)	All the tracks are played in random order.

¹⁾ Group play mode () appears whenever you play a disc with group settings. For more details, see "Playing a track in group play" (page 21).

- 4 Press ◀◀ or ▶▶ repeatedly until "RepOFF" or "RepON" (playing a track repeatedly) appears in the display, and then press ENT/▶▶ to enter the selection.

If you select "RepON", "⏮" appears on **B** and the playback repeats with the play mode selected in step 3.

B lights up when you press ENT/▶▶.

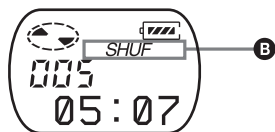

Display B	Play mode
⏮	Repeat play of all tracks
⏮ 1	Repeat play of a selected track
SHUF ⏮	Repeat shuffle play of all tracks

To cancel the procedure
Press MENU.

To return the preceding settings
Press ■/CANCEL.

Adjusting treble or bass (Digital Sound Preset)

You can adjust the treble and bass to suit your taste. The player can store two sets of treble-bass adjustments, which can then be selected later during playback.

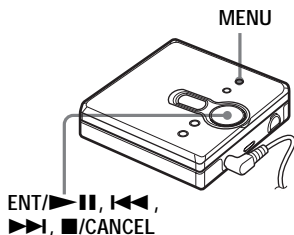

Selecting the sound quality

Factory settings

Factory settings of the digital sound preset are as follows:

- "SOUND1": bass +1, treble ± 0
- "SOUND2": bass +3, treble ± 0

- 1 While playing, press MENU.
- 2 Press ◀◀ or ▶▶ repeatedly until "SOUND" appears in the display, and press ENT/▶▶||.
- 3 Press ◀◀ or ▶▶ repeatedly to select "SOUND1", "SOUND2", or "OFF" in the display, and then press ENT/▶▶|| to enter the selection. Selecting "OFF" turns off the digital sound preset function.

Adjusting the sound quality

You can change the preset sound quality. To change the preset sound quality, select "SOUND1" or "SOUND2", the one you want to change, in advance.

- 1 While playing, press MENU.
- 2 Press ◀◀ or ▶▶ repeatedly until "SOUND" appears in the display, and then press ENT/▶▶||.
- 3 Press ◀◀ or ▶▶ repeatedly until "SET" appears in the display, and then press ENT/▶▶||.
- 4 Press ◀◀ or ▶▶ repeatedly until "SOUND1" or "SOUND2" appears in the display, and then press ENT/▶▶||.

The display shows the current "BASS" sound setting.

- 5 Press ◀◀ or ▶▶ repeatedly to adjust the sound level.

Shows "SOUND1" or "SOUND2" is selected



The sound can be adjusted in 8 steps. (-4, -3, ... ± 0 , ...+2, +3)

- 6 Press ENT/▶▶||. "BASS" is set and the display changes to "TRE" (treble) setting mode.
- 7 Press ◀◀ or ▶▶ repeatedly to adjust the sound level, and then press ENT/▶▶|| to enter the selection. "TRE" (treble) is set. The sound settings are saved and the playback display appears again.

To cancel the procedure
Press MENU.

To return the preceding
settings
Press ■/CANCEL.

Note

When using a digital sound preset, the sound may break or become distorted if the volume is turned up too high, depending on the settings or the track. In this case, change the settings of the sound quality.

What is the group function?

The group function is provided to allow playback of discs with group settings. The group function is convenient for playback of MDs on which several albums or CD singles have been recorded in MDLP (LP2/LP4) mode.

What is a disc with group settings?

The player can operate various functions in units of group; that is tracks that have been recorded on a disc as part of separate groups, as shown below.

Before group settings are made

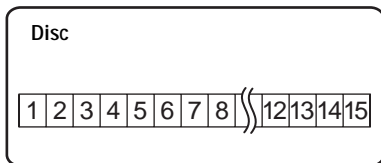

- Track 1 to 5 are assigned to group 1.
- Track 8 to 12 are assigned to group 2.
- Track 13 to 15 are assigned to group 3.
- Track 6 to 7 are assigned to no group.

After setting the group (group play)

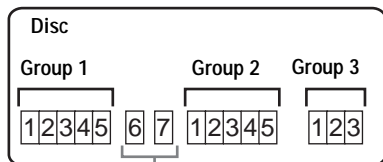

Tracks that were not assigned to a group are treated as being part of "GP --".

You can create a maximum of 99 groups on a disc.

Note

The player does not support the recording of group settings on the player. Use the supplied SonicStage software to assign tracks to group. For details, see "Software Operation" section (page 32).

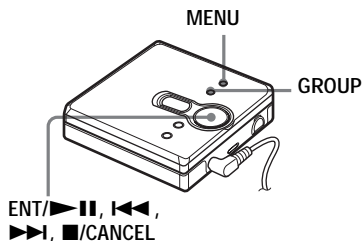

Playing a track in group play

In group play, all groups are played in order, starting with group 1, followed by the unassigned tracks ("GP --"). Playback stops after all the tracks have been played.

- 1 Press MENU.
- 2 Press ◀◀ or ▶▶ repeatedly until "P-MODE" appears in the display, and then press ENT/▶▶.
- 3 Press ◀◀ or ▶▶ repeatedly until "☐" and "Normal" appear in the display, and then press ENT/▶▶.
- 4 Press ◀◀ or ▶▶ repeatedly until "RepOFF" appears in the display, and then press ENT/▶▶ to enter the selection.

To cue to the start of a group (Group Skip)



- 1 While playing, press GROUP.
- 2 Press ◀◀ or ▶▶.
Pressing the ◀◀ or ▶▶ button cues to the first track of the previous or next group.

Selecting the play mode for group play (Group Play Mode)

The shuffle play and repeat play function can be used during group play mode.



- 1 Press MENU.
- 2 Press **◀◀** or **▶▶** until “P-MODE” appears in the display, and then press ENT/▶▶.
- 3 Press **◀◀** or **▶▶** repeatedly to select the play mode, and then press ENT/▶▶.

After normal playback (page 18), the following play modes are displayed.

Display	Play mode
 , Normal (Normal Group Play)	All tracks in the groups play back once (starting with the first track in group 1).
 , Shuff (In-Group Shuffle)	Shuffle play starts with the group that is currently playing, and continues with the succeeding groups.

- 4 Press **◀◀** or **▶▶** repeatedly until “RepOFF” or “RepON” appears in the display, and then press ENT/▶▶ to enter the selection.

If you select “RepON”, “↶” appears in the display and playback repeats in the respective group play mode (Group Repeat Play).

Display	Play mode
 , ↶	Repeat play of tracks within a group
 , SHUF ↶	Repeat shuffle play of tracks within a group

To cancel the procedure
Press MENU.

To return the preceding settings

Press **■**/CANCEL.

Viewing various information

You can check the track name, disc name, etc. during playback. Group-related items appear only when a track with group settings is played.

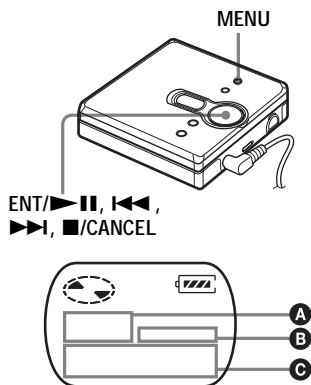

A	B	C
Track number	—	The elapsed time
Track number	♪	Track name
The number of total tracks in the groups	GP	Group name
The number of total tracks	◐	Disc name
Track number	—	Track mode

- 1 Press MENU.
- 2 Press ◀◀ or ▶▶ repeatedly until “DISP” appears in the display, and then press ENT/▶||.

- 3 Press ◀◀ or ▶▶ repeatedly until the information that you want appears in the display, and then press ENT/▶|| to enter the selection.

Each time you press ▶▶, the display changes as follows:

Display	Meaning
LapTim	The elapsed time of the current track
T:Name	Track name
G:Name	Group name
D:Name	Disc name
T-MODE	Indicates the recording mode selected on the MD player used; i.e., “SP”, “LP2”, “LP4”, or “MONO”.

Notes

- Depending on the group settings, the operating conditions and the disc settings, you may not be able to select certain indications or the indications may appear differently.
- The “T-MODE” indication appears only during playback. It appears for a few seconds, and is then replaced by the elapsed time of the current track.

To cancel the procedure
Press MENU.

To return the preceding settings
Press ■/CANCEL.

Starting the playback quickly (Quick Mode)

After pressing the playback button or cueing to the track, the playback can start quickly.

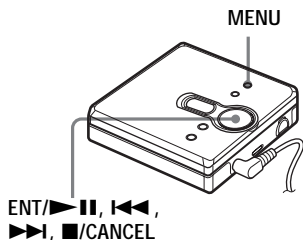

- 1 Press MENU.
- 2 Press ◀◀ or ▶▶ repeatedly until "OPTION" appears in the display, and then press ENT/▶||.
- 3 Press ◀◀ or ▶▶ repeatedly until "Power" appears in the display, and then press ENT/▶||.
- 4 Press ◀◀ or ▶▶ repeatedly until "QUICK" appears in the display, and then press ENT/▶||.

To switch back to the normal setting

Select "NORMAL" in step 4.

To cancel the procedure

Press MENU.

To return the preceding settings

Press ■/CANCEL.

Notes

- When the power mode is set to "QUICK", the power remains on within the player even when nothing appears in the display. This leads to a shorter battery life.
- If no player operation (including opening or closing of the lid) occurs for an hour, the power in the player automatically turn off. For this reason, the next time you start playback or do another operation, the player will not respond quickly. The unit, however, will return to quick mode afterwards.

Protecting your hearing (AVLS)

The AVLS (Automatic Volume Limiter System) function sets a maximum volume level to protect your ears.

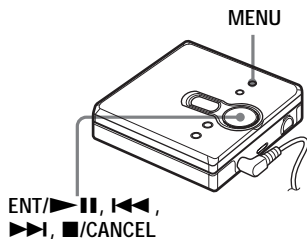

- 1 Press MENU.
- 2 Press ◀◀ or ▶▶ repeatedly until "OPTION" appears in the display, and then press ENT/▶||.
- 3 Press ◀◀ or ▶▶ repeatedly until "AVLS" appears in the display, and then press ENT/▶||.
- 4 Press ◀◀ or ▶▶ repeatedly until "ON" appears in the display, and then press ENT/▶|| to enter the selection.
"ON" appears in the display, and after a few seconds, the playback display appears again.

To cancel the AVLS function
Select "OFF" in step 4.

To cancel the procedure
Press MENU.

To return the preceding settings
Press ■/CANCEL.

Locking the controls (HOLD)

To prevent the buttons from being accidentally operated when you carry the player, use this function.

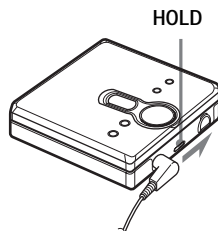

- 1 Slide HOLD in the direction of the → to lock.

To unlock the controls
Slide HOLD to the opposite direction of the arrow.

Precautions

On safety

- Do not carry or store the dry battery in the same place with metallic objects such as coins, key rings, or necklaces. This may cause a short-circuit and the generation of heat.
- Incorrect battery usage may cause the battery fluid to leak or battery to burst. To prevent such accidents, make sure the battery is installed with the + and – poles oriented correctly.
- If a battery leak should develop, carefully and thoroughly wipe away the battery fluid in the battery compartment before inserting a new battery.
- If you will not use the player for a long time, be sure to remove the dry battery.

On Handling

- Do not drop or bump the player. This may cause the player to malfunction.
- Do not pull headphones/earphones cords.
- Do not place the player in the following places:
 - An extremely hot place (over 60°C (140°F))
 - A place exposed to direct sunlight or near a heater
 - In a car with the windows rolled up (especially in the summer)
 - In a damp place such as a bathroom
 - Near a source of electromagnetic fields such as a magnet, speaker, or TV
 - In a dusty place

On heat build-up

Heat may build up in the player if it is used for an extended period of time. This, however, is not a malfunction.

On mechanical noise

The player emits mechanical noise while operating, which is caused by the power-saving system of the player. This is not a malfunction.

On installation

Never use the player where it will be subjected to extremes of light, temperature, moisture or vibration.

On the MiniDisc cartridge

- Do not touch the internal disc directly. Forcing the shutter open may damage the internal disc.
- When transporting a MiniDisc, keep it in its case.
- Do not place the cartridge where it will be subjected to light, temperature, moisture or dust.
- Do not affix the label outside of the specified area on the MD. Make sure the label is placed within the recessed space on the disc.

On the headphones/earphones

Road safety

- Do not use headphones/earphones while driving, cycling, or operating any motorized vehicle. This may lead to a traffic accident and is illegal in many areas. It can also be potentially dangerous to play your player at high volumes while walking, especially at pedestrian crossings. You should exercise extreme caution or discontinue using the player in potentially hazardous situations.
- If you experience an allergic reaction to the supplied headphones/earphones, stop using them at once and consult a doctor or a Sony service center.

Preventing hearing damage

Avoid using headphones/earphones at high volumes. Hearing experts advise against continuous, loud and extended play. If you experience a ringing in your ears, reduce the volume or discontinue use.

Caring for others

Keep the volume at a moderate level. This will allow you to hear outside sounds and to be considerate of the people around you.

On cleaning

- After wiping the player casing with a soft cloth slightly moistened with water, wipe it again with a dry cloth. Do not use any type of abrasive pad, scouring powder or solvent such as alcohol or benzene as this may mar the finish on the casing.
- Wipe the disc cartridge with a dry cloth to remove dirt.
- Dust on the lens may prevent the unit from operating properly. Be sure to close the disc compartment lid after inserting or ejecting an MD.
- To maintain good sound quality, use a soft cloth to clean the plugs of the headphones/earphones. A dirty plug may cause noise or intermittent breaks in the sound during playback.
- Clean the terminals periodically with a cotton swab or a soft cloth as illustrated.

Dry battery compartment

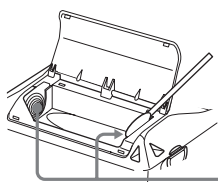

Terminals

When recording with the supplied application software

Before you remove the MD after the transfer of audio data from your computer has completed

Make sure that "TOC Edit" has disappeared in the display, and then press the ■ (stop) button.

If the power source (battery) accidentally becomes disconnected during recording

The lid may refuse to open. If this happens, do not open the lid by force. Do the steps below instead.

- 1 Connect the power source (battery) firmly to the player.
- 2 Press the OPEN button to open the lid.

To protect a recorded MD

To record-protect an MD, slide open the tab at the side of the MD. In this position, the MD cannot be recorded. To record again, slide the tab back so the tab is visible.

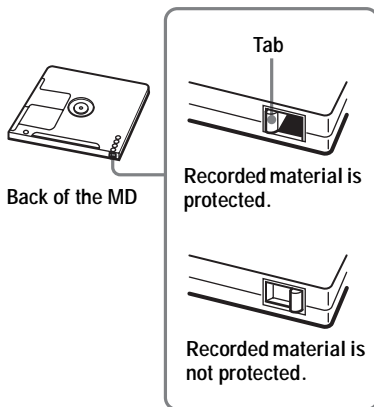

If you have any questions or problems concerning your player, please consult your nearest Sony dealer. (If a trouble occurred when the disc was in the player, we recommend that the disc be left in the player when you consult your Sony dealer so that the cause of trouble may be better understood.)

When consulting your Sony dealer, be sure to bring the player and the headphones/earphones.

Specifications

MD Player

Audio playing system

MiniDisc digital audio system

Laser diode properties

Material: GaAlAs

Wavelength: $\lambda = 790 \text{ nm}$

Emission duration: continuous

Laser output: less than 44.6 μW

(This output is the value measured at a distance of 200 mm from the objective lens surface on the optical pick-up block with 7 mm aperture.)

Recording and playback time (when using MDW-80)

Maximum 160 min. in monaural

Maximum 320 min. in LP4 stereo

Revolutions

Approx. 380 rpm to 2,700 rpm

Error correction

ACIRC (Advanced Cross Interleave Reed

Solomon Code)

Sampling frequency

44.1 kHz

Coding

ATRAC (Adaptive TRansform Acoustic Coding)

ATRAC3 — LP2/LP4

Modulation system

EFM (Eight to Fourteen Modulation)

Number of channels

2 stereo channels

1 monaural channel

Frequency response

20 to 20,000 Hz $\pm 3 \text{ dB}$

Outputs

ⓘ: stereo mini-jack, maximum output level

5 mW + 5 mW, load impedance 24 Ω (USA)

5 mW + 5 mW, load impedance 16 Ω (Canada)

General

Power requirements

One LR6 (size AA) alkaline battery (not supplied)

Recommended temperature for check-in/check-out

+5 °C (+41°F) or higher

Battery operation time

See "Battery life" (page 14)

Dimensions

Left-hand model on page 12

Approx. 81 × 28.9 × 74.4 mm (w/h/d) (3¹/₄ × 1³/₁₆ × 3 in.) without projections

Right-hand model on page 12

Approx. 81 × 30.7 × 74.4 mm (w/h/d) (3¹/₄ × 1¹/₄ × 3 in.) without projections

Mass

Left-hand model on page 12

Approx. 106 g (3.8 oz) the player only

Right-hand model on page 12

Approx. 113.3 g (4.0 oz) the player only

US and foreign patents licensed from Dolby Laboratories.

Design and specifications are subject to change without notice.

Optional accessories

MDR series stereo Headphones/earphones*

SRS series Active Speakers

- * When using optional headphones, use only headphones/earphones with stereo mini plugs. You cannot use headphones/earphones with micro plugs.

Your dealer may not handle some of the above listed accessories. Please ask the dealer for detailed information about the accessories in your country.





Troubles and solutions

If you find any troubles operating the player, follow the steps below.

- 1 Check this section, “Troubles and solutions” (page 29).
- 2 If you cannot solve the problem after you made checks, consult your nearest Sony dealer.

While playing

Symptom	Cause/Remedy
An MD is not played normally.	<ul style="list-style-type: none">• Repeat play is selected. ➔ Use MENU on the player to change back to the normal play (page 18).• Playback mode is changed. ➔ Use MENU on the player to change back to the normal play (page 18).
An MD is not played from the first track.	<ul style="list-style-type: none">• Disc playing stopped before it came to the last track. ➔ Press ► for 2 seconds or more to start playing.• Group play mode is selected. ➔ Use MENU on the player to change back to the normal play (page 18), and then press ► for 2 seconds or more to start playing.
The digital sound preset function does not work.	<ul style="list-style-type: none">• The digital sound preset is off. ➔ Select “SOUND1” or “SOUND2” (page 19).
Playback sound skips.	<ul style="list-style-type: none">• The player is placed where it receives continuous vibration. ➔ Put the player on a stable place.• A very short track may cause sound to skip. ➔ Try not to create a track under one second long.
Sound has a lot of static.	<ul style="list-style-type: none">• Strong magnetism from a television or such device is interfering with operation. ➔ Move the player away from the source of strong magnetism.
Noise is momentarily heard.	<ul style="list-style-type: none">• The sound was recorded in LP4 stereo mode. ➔ Because of the nature of the compression method used in LP4 mode, noise may be output on very rare occasions during playback of sound recorded in this mode.
Volume cannot be turned up.	<ul style="list-style-type: none">• AVLS is on. ➔ Release AVLS settings (page 25).

Symptom	Cause/Remedy
No sound comes through the headphones/earphones.	<ul style="list-style-type: none"> The headphones/earphones plug is not firmly connected. ➔ Plug in the plug of the headphones/earphones firmly to . Volume is too low. ➔ Adjust the volume by pressing VOL + or -. The plug is dirty. ➔ Clean the plug.
The player skips to several tracks ahead or behind when you press  or  .	<ul style="list-style-type: none"> The GROUP button has been pressed ( is flashing in the display). ➔ The player returns to normal if no operation has made for 5 seconds.
The edited tracks may exhibit sound dropout during search operations.	<ul style="list-style-type: none"> This occurs due to the MiniDisc system limitation. The fragmentation of data may cause sound dropout while searching because the tracks are played in higher speed than normal playback.

While using group function

Symptom	Cause/Remedy
The group function does not operate.	<ul style="list-style-type: none"> While using a disc with no group setting, an attempt was made to select some group-related menu (“No Gp” appears in the display). ➔ Use a disc with group setting.
A track cannot be checked out to a new group. A new group cannot be created on the supplied SonicStage software.	<ul style="list-style-type: none"> This is due to the MiniDisc system limitations. Group information has been written to the area where the disc name is stored. The disc name and track names are recorded in the same area, which can store a maximum of approximately 1,700 characters. If the total number exceeds this amount, a new group cannot be created even though group mode is on. It is also impossible to make group settings at this time.

Others

Symptom	Cause/Remedy
The player does not work or works poorly.	<ul style="list-style-type: none"> The volume is low. ➔ Turn up the volume. No disc is inserted (“NoDISC” appears in the display). ➔ Insert a recorded disc.

<p>The player does not work or works poorly.</p>	<ul style="list-style-type: none"> • The HOLD function is turned on (“HOLD” appears in the display when you press an operation button on the player). ➔ Disable HOLD by sliding the HOLD switch to the opposite direction of the arrow. • The lid is not firmly closed. ➔ Close the lid until it clicks. • Moisture has condensed inside the player. ➔ Take the MD out and leave the player in a warm place for several hours until the moisture evaporates. • The dry battery is weak (“LoBATT” flashes or nothing appears). ➔ Replace the dry battery with a new one. • The dry battery have been inserted incorrectly. ➔ Insert the battery correctly. • An MD with nothing recorded on is inserted (“BLANK” appears in the display). ➔ Insert a recorded MD. • The disc is damaged or does not contain proper recording (“Rd ERR” appears in the display). ➔ Reinsert the disc. If the error message still appears, replace it with another disc. • While operating, the player received a mechanical shock, too much static, abnormal power voltage caused by lightning, etc. ➔ Restart the operation as follows. <ol style="list-style-type: none"> 1 Remove the dry battery from the player. 2 Leave the player for about 30 seconds. 3 Insert the dry battery.
<p>The player will not play.</p>	<ul style="list-style-type: none"> • A Hi-MD disc or a standard disc in Hi-MD mode is inserted. ➔ Hi-MD discs or standard discs in Hi-MD mode cannot be played on this player.

Explanations

About the DSP TYPE-S for ATRAC/ATRAC3

This player supports playback with the DSP TYPE-S specification for high-level Sony MiniDisc decks equipped with digital signal processors (DSP). This specification allows tracks recorded in MDLP mode to be played back with high quality sound. Since this player also supports DSP TYPE-R specification, superb sound is produced during playback in SP (normal stereo) mode as well.

Suppressing the skips of the sound (G-PROTECTION)

The G-PROTECTION function was developed to provide a higher level of shock resistance than that of existing players.

What you can do with MD Simple Burner/SonicStage

What you can do with MD Simple Burner

MD Simple Burner allows you to record music tracks from an audio CD in the CD drive of your personal computer to an MD Walkman, without first recording the music tracks to the computer.



What you can do with SonicStage

SonicStage allows you to import audio data to your computer from music sources such as audio CDs and the Internet, and then transfer the audio data stored in your computer to an MD.

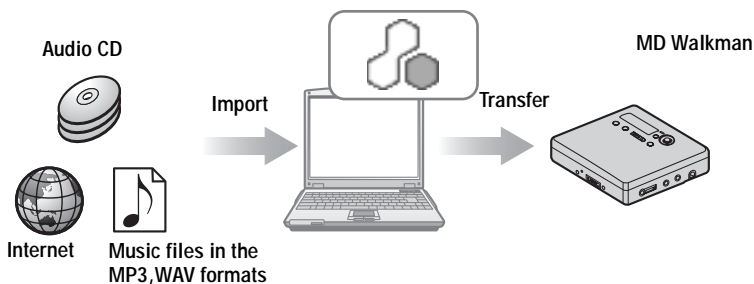

Basic operational flow using an MD Walkman

● MD Simple Burner

● SonicStage

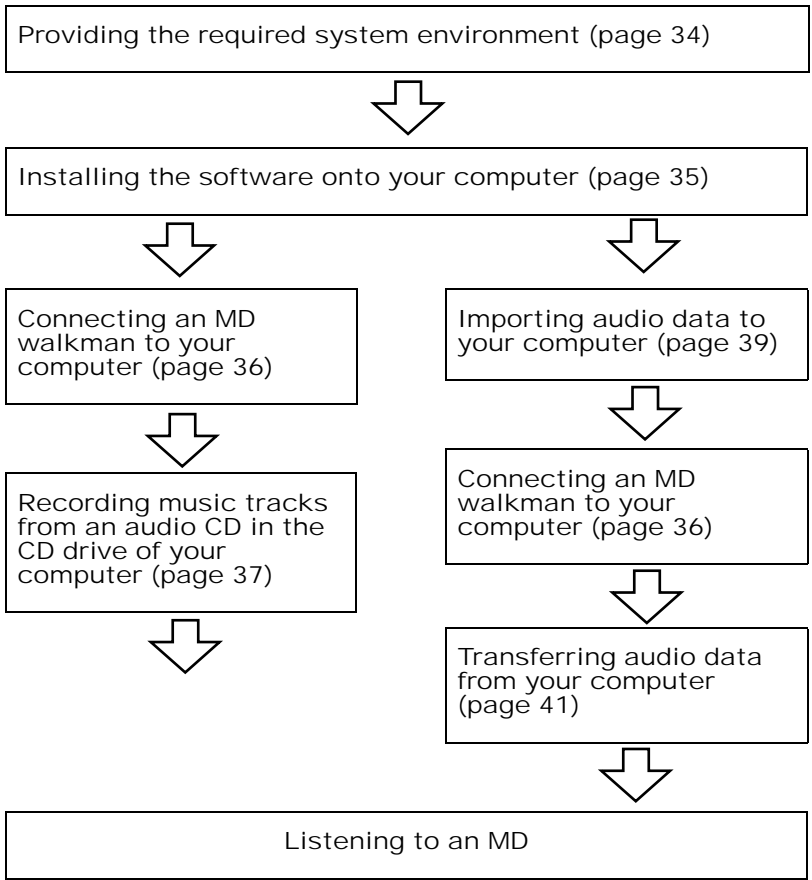

Providing the required system environment

System requirements

The following system environment is required in order to use the SonicStage Ver.2.0/MD Simple Burner Ver.2.0 software for the MD Walkman.

Computer	IBM PC/AT or Compatible
	<ul style="list-style-type: none">• CPU: Pentium II 400 MHz or higher (Pentium III 450 MHz or higher is recommended.)• Hard disk drive space: 200 MB or more (1.5 GB or more is recommended) (The amount space will vary according to Windows version and the number of music files stored on the hard disk.)• RAM: 64 MB or more (128 MB or more is recommended)
	Others <ul style="list-style-type: none">• CD drive (capable of digital playback by WDM)• Sound Board• USB port (supports USB (previously USB 1.1))
Operating System	Factory installed: Windows XP Media Center Edition 2004/Windows XP Media Center Edition/Windows XP Professional/Windows XP Home Edition/ Windows 2000 Professional/Windows Millennium Edition/Windows 98 Second Edition
Display	High Color (16bit) or higher, 800 × 600 dots or better (1024× 768 dots or better is recommended)
Others	<ul style="list-style-type: none">• Internet access: for Web registration, EMD services and CDDB• Windows Media Player (version 7.0 or higher) installed for playing WMA files

This software is not supported by the following environments:

- OSs other than the indicated above
- Personally constructed PCs or operating systems
- An environment that is an upgrade of the original manufacturer-installed operating system
- Multi-boot environment
- Multi-monitor environment
- Macintosh

Notes

- We do not ensure trouble-free operation on all computers that satisfy the system requirements.
- The NTFS format of Windows XP/Windows 2000 Professional can be used only with the standard (factory) settings.
- We do not ensure trouble-free operation of the system suspend, sleep, or hibernation function on all computers.
- For Windows 2000 Professional users, install Service Pack 3 or later version before using the software.

Installing the software onto your computer

Before installing the software

- Make sure to close any virus-check software, as such software usually demands a large amount of system resources.
- Even if OpenMG Jukebox, SonicStage, SonicStage Premium, SonicStage Simple Burner, or Net MD Simple Burner has been previously installed, install the software with the supplied CD-ROM. The existing software may be overwritten by the new version or it may co-exist with SonicStage depending on the version of your software. Follow the instructions that appear in the window for the installation.

You will still be able to use music data registered by a previous software version even if the previous version has been overwritten by or co-exists with new SonicStage Ver. 2.0. As a precaution, we recommend that you back up your music data. To back up the data, refer to [Backing Up My Library] – [Backing Up Data to a Disk] on SonicStage Help.

1 Turn on your computer and start up Windows.

2 Insert the supplied CD-ROM into the CD drive of your computer.

The setup program starts up automatically and the installation window appears.

Depending on the region, a window may appear asking you to select your country. In this case, follow the displayed instructions.

3 Click [Install SonicStage and MD Simple Burner] and then follow the displayed instructions.

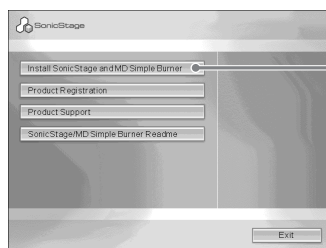

Click [Install SonicStage and MD Simple Burner]

Read the instructions carefully.

Depending on your region, the buttons other than [Install SonicStage and MD Simple Burner] may differ from those in the illustration above.

The installation may take 20 to 30 minutes, depending on your system environment. Make sure to restart your computer only after the installation is completed.

Was the installation successful?

If any trouble occurs during the installation, see “Troubleshooting” (page 51).

Connecting the MD Walkman to your computer

After the software installation is completed, connect the MD Walkman to your computer.

- 1 Insert a recordable disc into the MD Walkman.

- 2 Insert the new dry battery into the MD Walkman, and connect the MD Walkman to the computer using the supplied dedicated USB cable.

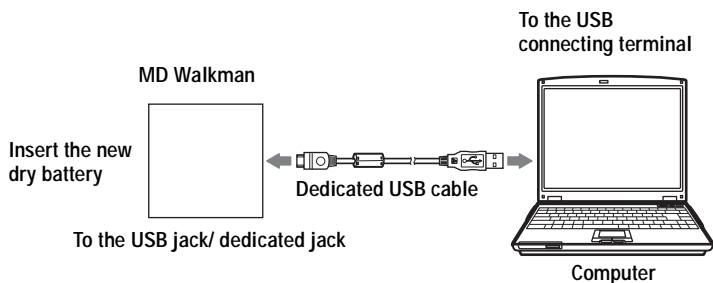

-
- 3 Check the connections.
When the connections have been properly made, "PC→MD"* appears in the display of the MD Walkman.
* Depending on the MD Walkman, "Net MD" may be displayed.
-

Note

When using the MD Walkman connected to your computer, it is recommended that you use a new dry cell battery. We do not assure the results should there be a mis-operation, transferring failure, or destruction of audio data caused by insufficient battery power.

Recording by computer operations



MD Simple Burner allows you to record music tracks from an audio CD in the CD drive of your personal computer to the MD Walkman.

To start MD Simple Burner, click [Start] – [All Programs]* – [MD Simple Burner] – [MD Simple Burner].

* [Programs] in the case of Windows 2000 Professional/Windows Millennium Edition/Windows 98 Second Edition



There are other ways to start up MD Simple Burner as follows:

- Double-click the  MD Simple Burner icon in the task tray, or right-click and select [Show Standard Mode].
- Double-click the  MD Simple Burner shortcut icon on the desktop.

Notes

- Only audio CDs with a  mark can be used with MD Simple Burner.
- We do not guarantee normal operation in the case of the copy-controlled CDs.

The window for recording all tracks on the CD

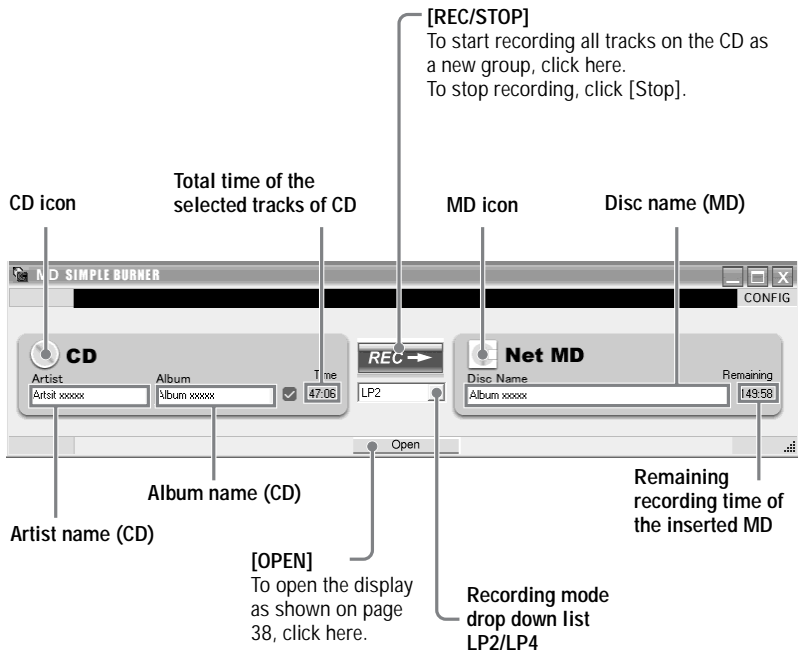

The window for recording selected tracks from an audio CD

Track information
(CD)

[CONFIG]

Click here to do the following:

- Set the CD-ROM drive
- View version information for MD Simple Burner
- Confirm CD information registered in the CDDB

Artist name

Total time of the
selected tracks of CD

Track information (MD)

You can change the
track name and track
number

Album Title

[REC/
STOP]

Disc name
(MD)

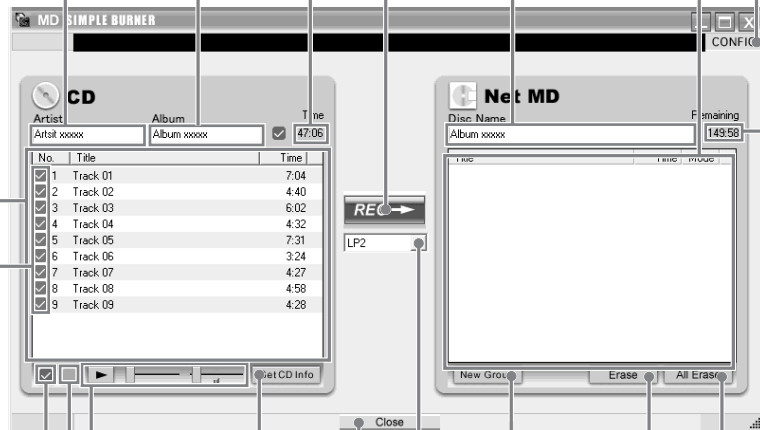

[Get CD info]

Information of an audio CD
(album name, track title,
etc.) will be reflected in the
track list.

[New Group]

Recording mode
drop down list

[CLOSE]

To close the display as shown
on page 37, click here.

CD operating section

Use these controls to confirm the tracks on audio CD to
be recorded

To deselect all tracks, click here.

To select all tracks, click here.

[Erase]

[All Erase]

Check boxes

Check the box of the tracks
that you want to record

Remaining time of the inserted MD

Importing audio data

This section explains how to record and store audio data from an audio CD to My Library of SonicStage on the hard disk drive of your computer.

You can record or import music from other sources such as the Internet and your computer's hard disk. Refer to SonicStage Help for details.

Notes

- Only audio CDs with a  mark can be used with SonicStage.
- We do not guarantee normal operation in the case of the copy-controlled CDs.

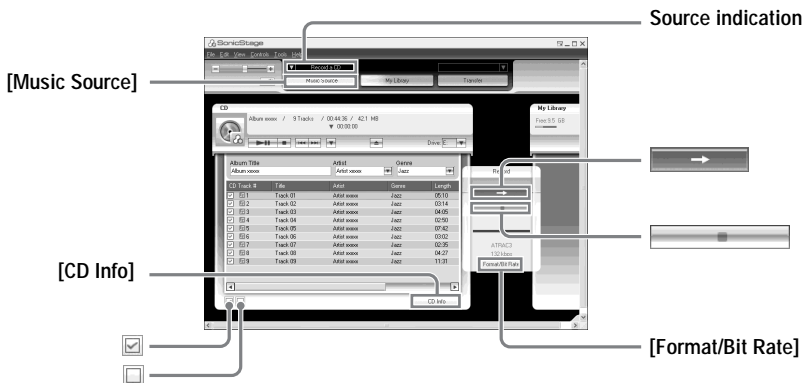

1 Start up SonicStage.

Select [Start] – [All Programs]* – [SonicStage] – [SonicStage].

* [Programs] in the case of Windows 2000 Professional/Windows Millennium Edition/Windows 98 Second Edition

SonicStage starts up and the main window appears.



You can also start SonicStage with double click  ([SonicStage] icon) on the desktop.

2 Insert the audio CD that you want to record into the CD drive of your computer.

The source indication in the top-left of the display changes to [Record a CD].

3 Click [Music Source].

The contents of the audio CD appear in the music source list (on the left side of the screen).

continued

4 If necessary, click to uncheck tracks you do not want to record.

If you unchecked a box by mistake, click it again to restore the check.

To check all boxes, click .

To uncheck all boxes, click .

5 If necessary, change the format and bit rate for recording the audio CD.

When you click [Format/Bit Rate] on the right side of the screen, “CD Recording Format [My library]” dialog box will appear. The dialog box will ask you to select the format and bit rate for recording the audio CD.

6 Click .

The recording of the tracks selected in step 4 starts.

To stop recording

Click .



To obtain album information such as the album titles in the CD track list, artist name, or track titles, click [CD Info] on the right side of the display.

Transferring audio data from your computer to the MD Walkman

Audio data stored in My Library of SonicStage can be transferred to your MD Walkman an infinite number of times.

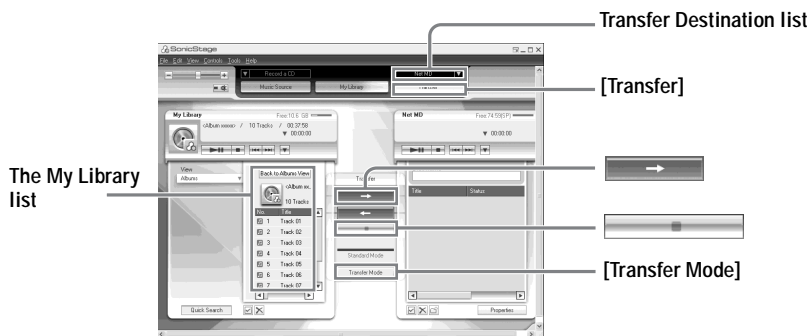

1 Connect your MD Walkman to the computer.

After making the connections, “Net MD” is displayed in the Transfer Destination list in the upper right of the screen.

For details about connections, see “Connecting the MD Walkman to your computer” (page 36).

Do not disconnect the power source or the dedicated USB cable before the transfer has completed.

2 Click [Transfer].

The screen is switched to the Transfer (Net MD) screen.

3 Click the tracks you want to transfer in the My Library list on the left side of the screen.

To transfer more than one track, hold down the [Ctrl] key while selecting the tracks. To transfer all tracks of the album, click the album.

4 Change the transfer mode, if necessary.

Click [Transfer Mode] in the middle of the screen to display the “Transfer Mode Settings” dialog box (for Net MD) and select the transfer mode.

continued

5 Click  .

Transfer of the tracks selected in step 3 begins.

To stop transferring

Click  .

Notes

- A transfer will fail and an error message will appear in the following cases:
 - When there is not enough free space on the MD disc.
 - When the track is subject to playback restrictions.
- During the transfer, the system suspend, sleep, or hibernation function will not operate.
- Depending on the type of the text and number of characters, the text entered by SonicStage may not be displayed on the connected MD Walkman. This is due to the limitations of the connected MD Walkman.
- When using your MD Walkman connected to the computer, be sure to use a new battery. We do not assure the results should there be a mis-operation, transferring failure, or destruction of audio data caused by insufficient battery power.

Transferring back audio data from the MD Walkman to your computer



Transferring from the MD Walkman back to your computer

Audio data that has been transferred from your computer and stored on the MD can be transferred back to My Library of SonicStage on your computer.

- 1** Connect your MD Walkman to the computer.
After making the connections, “Net MD” is displayed in the Transfer Destination list in the upper right of the screen.
For details about connections, see “Connecting the MD Walkman to your computer” (page 36).
Do not disconnect the power source or the dedicated USB cable before the transfer has completed.
- 2** Click [Transfer].
The screen is switched to the Transfer (Net MD) screen.
- 3** In the Net MD list on the right side of the screen, click to select the tracks you want to transfer to your computer.

continued

4 Click  in the middle of the screen.

The transferring of the tracks selected in step 3 starts.

To stop transferring

Click  .

Note

Tracks transferred to the MD Walkman from another computer cannot be transferred back to My Library on your computer.

Using SonicStage Help

SonicStage Help provides further details on how to use SonicStage. SonicStage Help allows you to search easily for information from a list of operations, such as “Importing audio data” or “Transferring audio data”, or from large list of keywords, or by typing in words that might lead you to the appropriate explanations.

To display SonicStage Help

Click [Help] – [SonicStage Help] while SonicStage is running.



You can display SonicStage Help by selecting the following:
[Start] – [All Programs]* – [SonicStage] – [SonicStage Help].

* [Programs] in the case of Windows 2000 Professional/Windows Millennium Edition/Windows 98 Second Edition

Notes

- In SonicStage Help, “Device/Media” is the general term for the external device such as the MD Walkman, the Network Walkman, and the CD Walkman.
- Follow the instructions of your internet provider regarding such things as recommended system.

Viewing how to use SonicStage Help

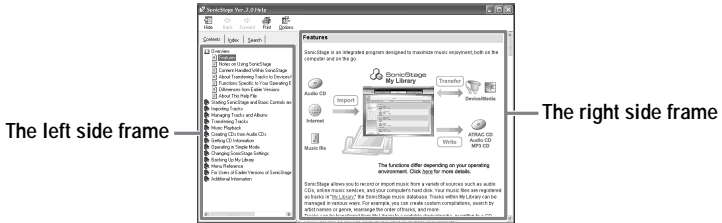

- 1 Double click [Overview] in the left-side frame.
- 2 Click [About This Help File].
The explanation will appear in the right-side frame.
- 3 Read the text.
Scroll the display if necessary.
Click underlined words to jump to their explanations.

Searching for a word inside an explanation

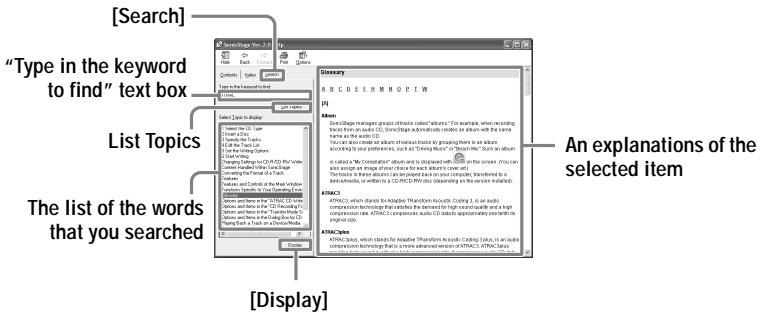

- 1 Click [Search] to open the "Search" window.
- 2 Type in the words.
- 3 Click [List Topics].
A list of the words that were searched is displayed.
- 4 Click to select the desired item among those displayed.
- 5 Click [Display].
An explanation of the selected item is displayed.

Referring to SonicStage Help

Click [Contents] on the left side of the Help window to view a list of items for each operation. Click on any items for details.

Importing audio data to the computer

To	SonicStage Help
Import audio data from the Internet	[Importing tracks] – [Purchasing Tracks from a Music Service Site]
Import audio files on the computer in SonicStage	[Importing tracks] – [Importing Music Files]

Listening to audio data on the computer

To	SonicStage Help
Listen to audio data from the CD drive or My Library	[Music Playback] – [Playing Back an Audio CD] or [Playing Back a Track in My Library]
Listen to audio data on the MD Walkman connected to the computer	[Music Playback] – [Playing Back a Track on a Device/Media]

Managing and editing imported tracks

To	SonicStage Help
Change information related to CD information downloading	[Changing SonicStage Settings] – [Changing Settings for Getting CD information]
Edit an album Delete the tracks	[Managing Tracks and Albums] – [Creating/Editing Albums]
Change the destination directly for track storage	[Changing SonicStage Settings] – [Changing the Location for Saving Recorded Files]

Backing up audio data

We recommend that you back up your music data as a precaution against hard disk crashes or computer replacement.

To	SonicStage Help
Back up audio data in My Library	[Backing Up My Library] – [Backing Up Data to a Disk]
Look up about SonicStage backup	[Backing Up My Library] – [FAQ-About SonicStage Backup Tool]

Troubleshooting

To	SonicStage Help
Look up troubleshooting procedure	[Additional Information] – [Troubleshooting]

When you want to know

To	SonicStage Help
Look up unknown words	[Additional Information] – [Glossary]
Look up the kinds of audio data that can be managed by SonicStage	[Overview] – [Content Handled Within SonicStage]
Look up the kinds of functions that can be used with SonicStage	[Overview] – [Features]

Uninstalling SonicStage/MD Simple Burner

To uninstall SonicStage/MD Simple Burner, follow the procedures below.

1 Click [Start]–[Control Panel]*.

* [Settings]–[Control Panel] in the case of Windows 2000 Professional/Windows Millennium Edition/Windows 98 Second Edition

2 Double-click [Add/Remove Programs].

3 Click [SonicStage 2.0.xx] or [MD Simple Burner 2.0.xx] in the “Currently Installed Programs” list, and then click [Change and Remove]*.

Follow the displayed instruction and restart your computer. The uninstallation is completed when the computer has restarted.

* [Change/Remove] in the case of Windows 2000 Professional, [Add/Remove] in the case of Windows Millennium Edition/Windows 98 Second Edition

Note

When you install SonicStage Ver.2.0/MD Simple Burner Ver.2.0, OpenMG Secure Module 3.4 is installed at the same time. Do not delete OpenMG Secure Module 3.4 since it may be used by other software.

On copyright protection

The OpenMG technology allows you to enjoy digital music, while maintaining the copyrights of its holders. SonicStage encrypts audio files in OpenMG format and stores them on the hard disk of your computer to prevent unauthorized distribution.

Restrictions on audio content

High-quality digital audio content is widely available through music distribution services on the Internet. To protect the copyrights of its holders from unauthorized distribution, some audio content is distributed with certain restrictions on recording and playback. For example, the playback period or playback count for the data may be limited.

Troubleshooting

Please refer to the following steps if you encounter a problem while using SonicStage/MD Simple Burner.

- 1 Check the symptoms in this “Troubleshooting” section.
- 2 Check the symptoms in SonicStage Help when you use SonicStage.
- 3 If the problem cannot be solved after checking the above references.
Check the following table and then consult your nearest Sony dealer.

Computer <ul style="list-style-type: none">• Manufacturer:• Model:• Type: Desktop type / Laptop type
Name of operating system:
RAM capacity:
Hard disk drive (containing SonicStage/MD Simple Burner and audio data) <ul style="list-style-type: none">• Capacity of the drive:• Free space:
Version of the software <ul style="list-style-type: none">• SonicStage Ver. 2.0¹⁾• MD Simple Burner Ver.2.0²⁾
Error Message (if one appear):
If an externally connected CD-ROM drive is used <ul style="list-style-type: none">• Manufacturer:• Model:• Type: CD-ROM / CD-R/RW / DVD-ROM / Other ()• Type of connection to the computer: PC card / USB / IEEE1394 / Other ()
If another device with USB connection is used <ul style="list-style-type: none">• Name of the device (or devices):

- ¹⁾ To check the SonicStage software version, go to [Help] – [About SonicStage] in the SonicStage window.
- ²⁾ To check the MD Simple Burner software version, go to [CONFIG] – [Version] in the MD Simple Burner window.

The software cannot be installed onto your computer

Problem	Cause/Remedy
The installation was not successful.	<p>You are using an OS that does not support this software. → See page 34 for more details.</p> <p>All windows applications are not closed. → If you start the installation while other programs are running, a malfunction may occur. This is especially true for programs that require large amounts of system resources, such as virus-check software.</p> <p>There is not enough hard disk space on your hard disk. → You need 200MB or more free space on your hard disk.</p>
The installation appears to have stopped before it has completed.	<p>Check for the appearance of an error message beneath the installation window. → Press the [Tab] key while holding down the [Alt] key. If an error message has appeared, press the [Enter] key. The installation will resume. If there is no message, the installation is still in progress. Wait a little while longer.</p>
The progress bar on the display is not moving. The access lamp has not lit for a few minutes.	<p>The installation is progressing normally. Please wait. The installation may take 30 minutes or more, depending on your CD drive or system environment.</p>

Using a MD Walkman connected to the computer

Problem	Cause/Remedy
Your computer does not recognize the MD Walkman.	The MD Walkman is not firmly connected with the supplied dedicated USB cable to the computer. →Reconnect the MD Walkman to the computer firmly. A disc is not inserted in the MD Walkman. →Check if a disc is inserted in the MD Walkman. The Net MD driver is not be installed. →Install the SonicStage/MD Simple Burner software using the supplied CD-ROM.
Even though the dedicated USB cable is used to connect the MD Walkman to the computer, the display on the MD Walkman does not indicate it is connected.	It takes time to recognize SonicStage. Please wait. The other application software is running. →Reconnect the supplied dedicated USB cable after a while. If the computer still does not recognize the MD Walkman, disconnect the MD Walkman, restart the computer, and connect the dedicated USB cable again.
The progress bar on the display is not moving. The access lamp has not lit for a few minutes.	The supplied dedicated USB cable is disconnected. →Connect the supplied dedicated USB cable firmly. The connections are made through a USB hub. →Operations are not guaranteed for USB-hub connections. Connect the MD Walkman directly to the USB connector on the computer.

Index

A

Accessories

- optional 28
- supplied 11

AVLS 25

B

Battery life 14

C

CD drive 34

CDDB 34

CD-ROM 35

Cleaning 27

Connecting 36

Copyright protection 50

D

Digital Sound Preset 19

DSP TYPE-S 31

E

EMD service 34

G

G-PROTECTION 17

Group

- function 21
- play 21
- skip 21

H

Hard disk

- free space 34

HOLD 15, 25

I

Importing 39

Index search 17

Installing 34

M

MD Simple Burner 37

My Library 39

O

OpenMG Secure Module 3.4 49

P

Play mode

- group 22
- tracks 18

Q

Quick Mode 24

R

Recording mode (Bit rate) 40

S

SonicStage 39

SonicStage Help 45

SonicStage Ver.2.0 11

Start (software)

- MD Simple Burner 37

- SonicStage 39

System environment 34

System limitations 34

T

Time search 17

Transferring

- to the MD Walkman 41
- to your computer 43

U

Uninstalling 49

USB cable 11

USB port 34

W

Windows 2000 Professional 34, 37, 39, 45, 49

Windows 98 Second Edition 34, 37, 39, 45, 49

Windows Media Player 34

Windows Millennium Edition 37, 39, 45, 49

Windows XP Home Edition 34

Windows XP Media Center Edition 34

Windows XP Media Center Edition 2004 34

Windows XP Professional 34

WMA 34

This warranty is valid only in Canada.

SONY[®]

Portable Memory Stick Audio Player
Portable IC Audio Player
Portable MiniDisc Recorder

LIMITED WARRANTY

Sony of Canada ("Sony") warrants this Product (including any accessories) against defects in material or workmanship as follows:

1. **LABOUR:** For a period of 90 days from the date of purchase, if this Product is determined to be defective, Sony will repair or replace the Product, at its option, at no charge, or pay the labour charges to any Sony authorized service facility. After the Warranty Period, you must pay for all labour charges.
2. **PARTS:** In addition, Sony will supply, at no charge, new or rebuilt replacements in exchange for defective parts for a period of one (1) year. After 90 days from the date of purchase, labour for removal and installation is available from Sony authorized service facilities or a Sony Service Centre at your expense.

You can extend the warranty period for an additional nine months by registering your product (www.sonystyle.ca). Once you register your product, the limited warranty period is twelve months from the original date of purchase from Sony or a Sony authorized dealer. The ninety (90) day warranty period is extend-able only to the original purchaser, for an additional period of nine (9) months, for a total of twelve (12) months from the date of purchase when the Product is registered electronically. After the applicable period you must pay for all parts and labour charges.

To obtain warranty service, you must take the Product, or deliver the Product freight prepaid, in either its original packaging or packaging affording an equal degree of protection, to any authorized Sony service facility.

This warranty does not cover customer instruction, installation, set up adjustments or signal reception problems.

This warranty does not cover cosmetic damage or damage due to acts of God, accident, misuse, abuse, negligence, commercial use, or modification of, or to any part of the Product, including the antenna. This warranty does not cover damage due to improper operation or maintenance, connection to improper voltage supply, or attempted repair by anyone other than a facility authorized by Sony to service the Product. This warranty does not cover Products sold AS IS or WITH ALL FAULTS, or consumables (such as fuses or batteries). This warranty is valid only in Canada.

Proof of purchase in the form of a bill of sale or receipted invoice which is evidence that the unit is within the Warranty period must be presented to obtain warranty service.

This warranty is invalid if the factory-applied serial number has been altered or removed from the Product.

REPAIR OR REPLACEMENT AS PROVIDED UNDER THIS WARRANTY IS THE EXCLUSIVE REMEDY OF THE CONSUMER. SONY SHALL NOT BE LIABLE FOR ANY INCIDENTAL OR CONSEQUENTIAL DAMAGES FOR THE BREACH OF ANY EXPRESS OR IMPLIED WARRANTY ON THIS PRODUCT, EXCEPT TO THE EXTENT PROHIBITED BY APPLICABLE LAW. ANY IMPLIED WARRANTY OF MERCHANTABILITY OR FITNESS FOR A PARTICULAR PURPOSE ON THIS PRODUCT IS LIMITED IN DURATION TO THE DURATION OF THIS WARRANTY.

Some provinces do not allow the exclusion or limitation of incidental or consequential damages, or allow limitations on how long an implied warranty lasts, so the above limitations or exclusions may not apply to you. This warranty gives you specific legal rights, and you may have other rights which vary from province to province.

For your convenience, Sony of Canada Ltd. has established telephone numbers for frequently asked questions:

To locate the service or dealer nearest you, or for service assistance or resolution of a service problem, or for product information or operation, call:

Sony Customer Information Center

1 (877) 770-7669

or write to:

Sony of Canada Ltd.

115 Gordon Baker Road, Toronto, Ontario M2H 3R6 CANADA

or visit:

www.sonystyle.ca/productregistration

Portable Audio

This information is used to process your warranty registration and for after-sales support purposes. It may also be used by Sony of Canada Ltd. and affiliated Sony companies for customer relationship development and analysis, and to provide you with information and promotional offers on other products and services that may be of interest to you. For a copy of our Privacy Code, please visit our website at www.sonystyle.ca/privacy or call 1-877-899-7669.

D 324511301

This warranty is valid only in the United States.

SONY®

Portable Memory Stick Audio Player/
Portable MiniDisc Recorder/
Portable CD Player

Portable Audio

LIMITED WARRANTY

Sony Electronics Inc. ("Sony") warrants this Product (including any accessories) against defects in material or workmanship as follows:

1. **LABOR:** For a period of 90 days from the date of purchase, if this Product is determined to be defective, Sony will repair or replace the Product, at its option, at no charge, or pay the labor charges to any Sony authorized service facility. After the Warranty Period, you must pay for all labor charges.

2. **PARTS:** In addition, Sony will supply, at no charge, new or rebuilt replacements in exchange for defective parts for a period of one (1) year. After 90 days from the date of purchase, labor for removal and installation is available from Sony authorized service facilities or a Sony Service Center at your expense.

To obtain warranty service, you must take the Product, or deliver the Product freight prepaid, in either its original packaging or packaging affording an equal degree of protection, to any authorized Sony service facility.

This warranty does not cover customer instruction, installation, set up adjustments or signal reception problems.

This warranty does not cover cosmetic damage or damage due to acts of God, accident, misuse, abuse, negligence, commercial use, or modification of, or to any part of the Product, including the antenna. This warranty does not cover damage due to improper operation or maintenance, connection to improper voltage supply, or attempted repair by anyone other than a facility authorized by Sony to service the Product. This warranty does not cover Products sold AS IS or WITH ALL FAULTS, or consumables (such as fuses or batteries). This warranty is valid only in the United States.

Proof of purchase in the form of a bill of sale or receipted invoice which is evidence that the unit is within the Warranty period must be presented to obtain warranty service.

This warranty is invalid if the factory applied serial number has been altered or removed from the Product.

REPAIR OR REPLACEMENT AS PROVIDED UNDER THIS WARRANTY IS THE EXCLUSIVE REMEDY OF THE CONSUMER. SONY SHALL NOT BE LIABLE FOR ANY INCIDENTAL OR CONSEQUENTIAL DAMAGES FOR BREACH OF ANY EXPRESS OR IMPLIED WARRANTY ON THIS PRODUCT. EXCEPT TO THE EXTENT PROHIBITED BY APPLICABLE LAW, ANY IMPLIED WARRANTY OF MERCHANTABILITY OR FITNESS FOR A PARTICULAR PURPOSE ON THIS PRODUCT IS LIMITED IN DURATION TO THE DURATION OF THIS WARRANTY.

Some states do not allow the exclusion or limitation of incidental or consequential damages, or allow limitations on how long an implied warranty lasts, so the above limitations or exclusions may not apply to you. In addition, if you enter into a service contract with the Sony Partnership within 90 days of the date of sale, the limitation on how long an implied warranty lasts does not apply to you. This warranty gives you specific legal rights, and you may have other rights which vary from state to state.

For your convenience, Sony Electronics Inc. has established telephone numbers for frequently asked questions:

To locate the servicer or dealer nearest you, or for service assistance or resolution of a service problem, or for product information or operation, contact:

www.sony.com/walkmansupport

Sony Network Portable Audio Support Line
1-866-456-7669

For an accessory or part not available from your authorized dealer, call:

1-800-488-SONY (7669)

D 324343303



Printed using VOC (Volatile Organic Compound)-free vegetable oil ink.

<http://www.sony.net/>

Printed in Malaysia



* 3 2 6 3 4 1 1 1 1 *

(1)