

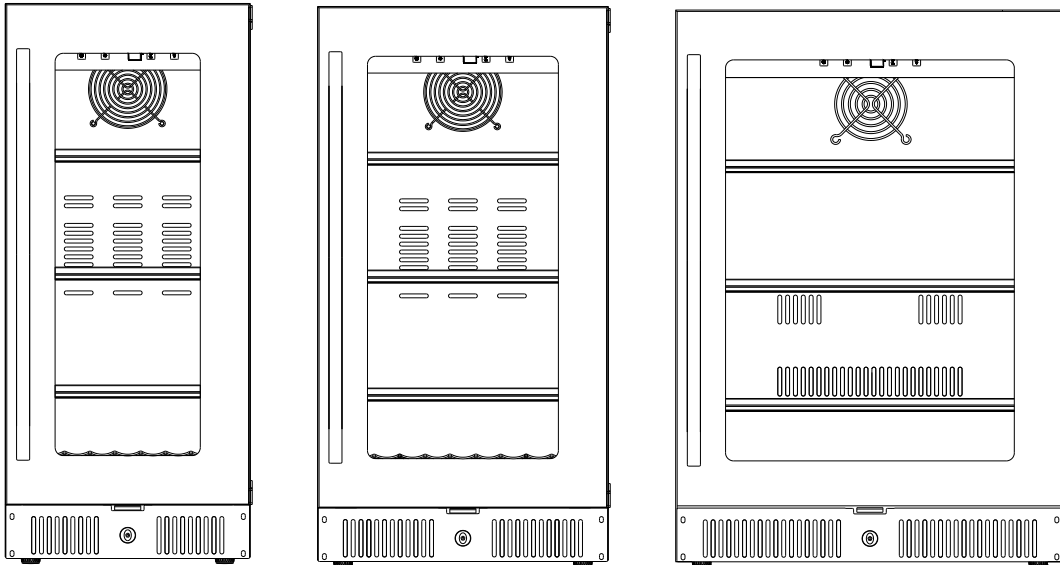

SUMMIT CLASSIC COLLECTION

## BEVERAGE MERCHANDISERS

*Model Nos.: CL156BV / CL186BV / CL24BV*



### *Instruction Manual*

**BEFORE USE, PLEASE READ AND FOLLOW ALL SAFETY RULES AND OPERATING INSTRUCTIONS.**

*Write Model and Serial No. (on lower left corner of inside cabinet) here:*

Model: \_\_\_\_\_

Serial No: \_\_\_\_\_

Felix Storch, Inc.  
An ISO 9001:2015 registered company  
770 Garrison Avenue  
Bronx, NY 10474  
[www.summitappliance.com](http://www.summitappliance.com)

# TABLE OF CONTENTS

<b>Appliance Safety</b>	<b>3</b>
<b>Important Safeguards</b>	<b>3-5</b>
<b>Disposal</b>	<b>5</b>
<b>Location of Parts</b>	<b>6-7</b>
<b>Installation Instructions</b>	<b>8-11</b>
<i>Before Using your Appliance</i>	8
<i>Installation of your Appliance</i>	8
<i>Electrical Connection</i>	9
<i>Anti-Tip Bracket</i>	10
<i>Installing the Stainless Steel Handle</i>	10
<b>Operating your Appliance</b>	<b>11-13</b>
<i>Control Panel</i>	11-12
<i>Interior Light</i>	12
<i>Sabbath Mode</i>	12
<i>Temperature Memory Function</i>	12
<i>Temperature Alarm/Door Alarm</i>	12
<i>Shelves</i>	13
<i>Defrosting</i>	13
<b>Care and Maintenance</b>	<b>13-14</b>
<i>Cleaning your Beverage Merchandiser</i>	13
<i>Power Failure</i>	13
<i>Moving your Appliance</i>	14
<i>Energy-Saving Tips</i>	14
<b>Troubleshooting</b>	<b>14-15</b>
<b>Limited Warranty</b>	<b>16</b>

# APPLIANCE SAFETY

Your safety and the safety of others are very important.

We have provided many important safety messages in this manual and on your appliance. Always read and obey all safety messages.



This is the Safety Alert Symbol. The symbol alerts you to potential hazards that can kill or injure you and others. All safety messages will follow the Safety Alert Symbol and either the words "DANGER" or "WARNING".



DANGER means that failure to heed this safety statement may result in severe personal injury or death.



WARNING means that failure to heed this safety statement may result in extensive product damage, serious personal injury, or death.

All safety messages will alert you about the potential hazard, tell you how to reduce the chance of injury, and let you know what can happen if the instructions are not followed.

---

## IMPORTANT SAFEGUARDS



Before the appliance is used, it must be properly positioned and installed as described in this manual, so read the manual carefully. To reduce the risk of fire, electrical shock or injury when using the appliance, follow basic precautions, including the following:



- Plug into a grounded 3-prong outlet, do not remove grounding prong, do not use an adapter, and do not use an extension cord.
- It is recommended that a separate circuit serving only your appliance be provided. Use receptacles that cannot be turned off by a switch or pull chain.
- Never clean appliance parts with flammable fluids. These fumes can create a fire hazard or explosion. And do not store or use gasoline or other flammable vapors and liquids in the vicinity of this or any other appliance. The fumes can create a fire hazard or explosion.
- Before proceeding with cleaning and maintenance operations, make sure the power line of the unit is disconnected.
- Do not connect or disconnect the electric plug when your hands are wet.
- Unplug the appliance or disconnect power before cleaning or servicing. Failure to do so can result in electrical shock or death.
- Do not attempt to repair or replace any part of your appliance unless it is specifically recommended in this manual. All other servicing should be referred to a qualified technician.
- This appliance is CFC- and HFC-free and contains a small quantity of Isobutane (R600a) which is environmentally friendly, but flammable. It does not damage the ozone layer, nor does it increase the greenhouse effect. Care must be taken during transportation and setting up of the appliance that no parts of the cooling system are damaged. Leaking coolant can ignite and may damage the eyes.

- In the event of any damage:
  - Avoid open flames and anything that creates a spark,
  - Disconnect from the electrical power line,
  - Air the room in which the appliance is located for several minutes and
  - Contact the Service Department for advice.
- The more coolant there is in an appliance, the larger the room it should be installed in. In the event of a leakage, if the appliance is in a small room, there is the danger of combustible gases building up. For every ounce of coolant at least 325 cubic feet of room space is required. The amount of coolant in the appliance is stated on the data plate inside the appliance. It is hazardous for anyone other than an Authorized Service Person to carry out servicing or repairs to this appliance.
- Take serious care when handling, moving, and using the appliance to avoid either damaging the refrigerant tubing or increasing the risk of a leak.
- Replacing component parts and servicing shall be done by factory authorized service personnel so as to minimize the risk of possible ignition due to incorrect parts or improper service.
- This appliance is not intended for use by persons (including children) with reduced physical, sensory or mental capabilities, or lack of experience and knowledge, unless they have been given supervision or instruction concerning use of the appliance by a person responsible for their safety. Children should be supervised to ensure that they do not play with the appliance.

## **WARNING**

### FOLLOW WARNING CALLOUTS BELOW ONLY WHEN APPLICABLE TO YOUR MODEL

- Use two or more people to move and install appliance. Failure to do so can result in back or other injury.
- **WARNING:** Keep ventilation openings, in the appliance enclosure or in the built-in structure, clear of obstruction.
- **WARNING:** Do not use mechanical devices or other means to accelerate the defrosting process, other than those recommended by the manufacturer.
- **WARNING:** Do not damage the refrigerant circuit.
- **WARNING:** Do not use electrical appliances inside the food storage compartments of the appliance, unless they are of the type recommended by the manufacturer.
- To ensure proper ventilation for your appliance, the front of the unit must be completely unobstructed. Choose a well-ventilated area with temperatures above 60°F (16°C) and below 90°F (32°C). [The unit performs best when the ambient temperature is in the range 72 – 78°F (23° – 26°C).] This unit must be installed in an area protected from the elements, such as wind, rain, water spray or drips.
- The appliance should not be located next to ovens, grills or other sources of high heat.
- The appliance must be installed with all electrical, water and drain connections in accordance with state and local codes. A standard electrical supply (115 V AC only, 60 Hz), properly grounded in accordance with the National Electrical Code and local codes and ordinances, is required.
- If the supply cord is damaged, it must be replaced by the manufacturer, its service agent or similarly qualified person in order to avoid a hazard.
- Do not kink or pinch the power supply cord of the appliance.
- The size of the fuse (or circuit breaker) should be 15 amperes.
- It is important that the appliance be leveled in order to work properly. You may need to make several adjustments to level it.
- All installations must be in accordance with local plumbing code requirements.
- Make certain that the pipes are not pinched, kinked or damaged during installation.
- Check for leaks after connection.
- Never allow children to operate, play with or crawl inside the appliance.
- Do not use solvent-based cleaning agents or abrasives on the interior. These cleaners may damage or discolor the interior.
- Use this appliance only for its intended purpose as described in this *Instruction Manual*.
- Keep fingers out of the “pinch point” areas. Clearances between the door and cabinet are necessarily small. Be careful closing the door when children are in the area.



**DANGER**

***Risk of child entrapment!***

Child entrapment and suffocation are not problems of the past. Junked or abandoned appliances are still dangerous, even if they will “just sit in the garage a few days”.

*Before discarding your old refrigerator:*

- *Take off the door*
- *Leave the shelves in place so that children may not easily climb inside.*

**- SAVE THESE INSTRUCTIONS -**

---

## **DISPOSAL**

Dispose of your appliance packaging properly. Ensure that any plastic wrappings, bags, etc., are disposed of safely and kept out of the reach of babies and young children. **Danger of suffocation!**

Refrigeration equipment must be properly disposed of in a professional and appropriate way, in accordance with the current local regulations and laws which protect the environment. This applies to your old appliance and to your new unit once it has reached the end of its service life.

**WARNING:** Please ensure that old, worn appliances are rendered unusable before disposal by removing the door, removing the plug, cutting the network cable, and removing or destroying any snap fastenings or bolts. Leave shelving in place. You will thus prevent children from locking themselves in the appliance during play (risk of suffocation) or endangering their lives in any other way. **DO NOT** dispose of the appliance in landfill as the insulation (Cyclopentane) and refrigerant gas (R600a) contained in these appliances are flammable.

### **Disposal instructions:**

- The appliance must not be disposed of in the dustbin or with normal household rubbish.
- The coolant circuit, particularly the heat exchanger at the back/bottom of the unit, must not be damaged.
- The appliance is not to be handled as normal household waste but is to be taken to a recycling collection point for electrical and electronic goods. By correctly disposing of this product you are contributing to the protection of the environment and to the health of your fellow human beings. Improper disposal endangers health and the environment. Further information about the recycling of the product may be obtained from your town hall, sanitation department or the store where you purchased the product.

# LOCATION OF PARTS

**Model CL156BV**

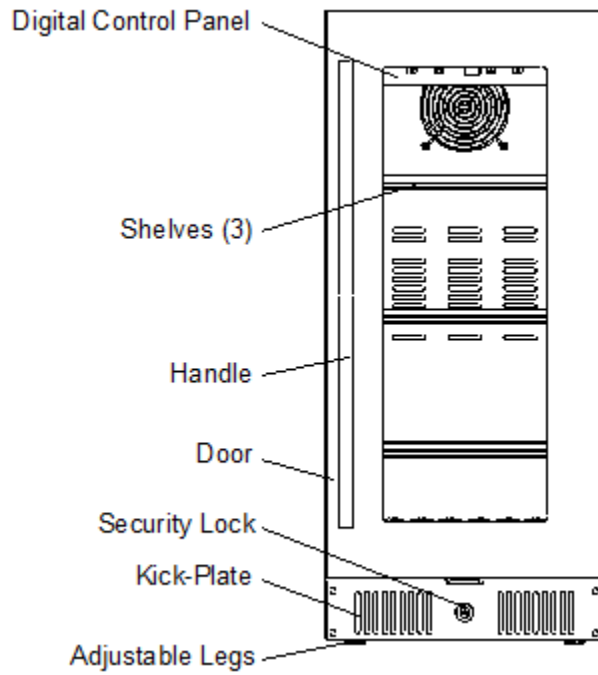

**Model CL186BV**

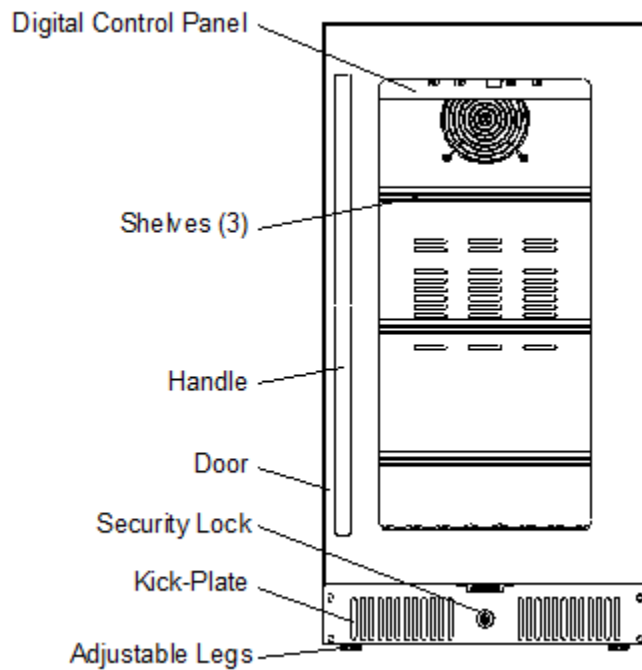

**Model CL24BV**

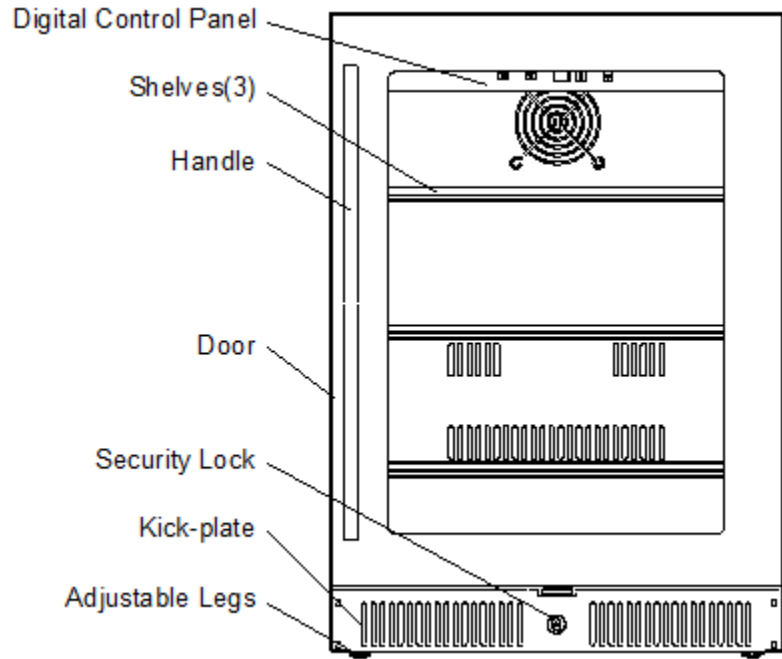

# INSTALLATION INSTRUCTIONS



## Before Using the Appliance

- Remove the exterior and interior packing.

*CAUTION: After unpacking you **MUST** allow this appliance to stand upright for at least 2 hours to allow the lubricant and refrigerant to drain back into the compressor and stabilize. Failure to do so may adversely affect performance and the lifetime of this unit.*

- Clean the interior surface with lukewarm water using a soft cloth.
- Install the handle on the door. (See page 10.)

## Installation of your Appliance

- The appliance is designed for built-in, recessed or free-standing installation.
- **WARNING:** Do not store or install the appliance outdoors.

*CAUTION: This appliance is designed for storing and cooling beverages and drinks. Do not store perishable food, medicine or other medical products.*

- Place your Beverage Merchandiser on a floor that is strong enough to support it when it is fully loaded. To level the unit, adjust the front leveling legs.
- For freestanding installation, 5" (127mm) of space at the back and sides of the unit and 4" (102mm) at the top are suggested, which allows the proper air circulation to cool the compressor and condenser for energy saving.
- Even for built-in installation, it is a must to keep at least 3/16" (5mm) of space on each side, 2" (50mm) at the back and 1/16" (1.6mm) at the top to ensure proper service access and ventilation. And the air vent at the front of the appliance must never be covered or blocked in any way.

*CAUTION: Make sure that the socket and ON/OFF switch are easily accessible after the appliance has been installed.*

- Avoid locating the unit in moist areas.

**NOTE:** It is recommended that you do not install the appliance near an oven, radiator or other heating source. Direct sunlight may affect the acrylic coating and heat sources may increase electrical consumption. Do not install in a location where the temperature will fall below 60°F (16°C). For best performance, do not install the appliance behind a cabinet door or block the base grille.

- Plug the Beverage Merchandiser into an exclusive, properly grounded wall outlet. Do not under any circumstances cut or remove the third (ground) prong from the power cord. Any questions concerning power and/or grounding should be directed toward a certified electrician or an authorized service center.

## Electrical Connection



## **WARNING**

Improper use of the grounded plug can result in the risk of electrical shock. If the power cord is damaged, have it replaced by a qualified electrician or an authorized service center.

This appliance should be properly grounded for your safety. The power cord of this appliance is equipped with a three-prong plug that mates with standard three-prong wall outlets to minimize the possibility of electrical shock.

Do not under any circumstances cut or remove the third (ground) prong from the power cord supplied. For personal safety, this appliance must be properly grounded.

This appliance requires a standard 115/120 Volt AC ~60Hz three-prong grounded electrical outlet. Have the wall outlet and circuit checked by a qualified electrician to make sure the outlet is properly grounded. When a standard 2-prong wall outlet is encountered, it is your responsibility and obligation to have it replaced with a properly grounded 3-prong wall outlet.

To prevent accidental injury, the cord should be secured behind the appliance and not left exposed or dangling.

The appliance should always be plugged into its own individual electrical outlet which has a voltage rating that matches the rating label on the appliance. This provides the best performance and also prevents overloading house wiring circuits that could cause a fire hazard from overheating. Never unplug the appliance by pulling on the power cord. Always grip the plug firmly and pull straight out from the receptacle. Repair or replace immediately all power cords that have become frayed or otherwise damaged. Do not use a cord that shows cracks or abrasion damage along its length or at either end. When moving the appliance, be careful not to damage the power cord.

### **Electrical Connection**

Because of potential safety hazards under certain conditions, it is strongly recommended that you do not use an extension cord with this appliance. However, if you must use an extension cord it is absolutely necessary that it be a UL/CUL-Listed, 3-wire grounding type appliance extension cord having a grounding type plug and outlet and that the electrical rating of the cord be 115 volts and at least 10 amperes.

## **Anti-Tip Bracket Installation**

To reduce the risk of tipping the unit by abnormal usage or improper loading, the appliance must be secured by properly installing the anti-tip device packed with the appliance.

- Place the anti-tip bracket on the floor as shown in the figure. An anti-tip bracket must be installed at the left side.
- Mark the locations of the 4 holes of the anti-tip bracket on the floor.
- Use a 5/16" masonry drill bit and insert plastic anchors.
- Secure bracket to floor using screws.
- Slide appliance into position and make sure the leg engages the anti-tip bracket.

**NOTE:** If the unit is relocated, the bracket must be removed and installed in the new location.

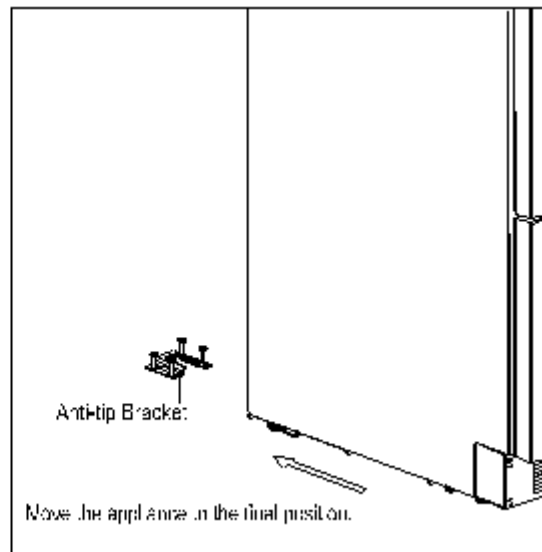
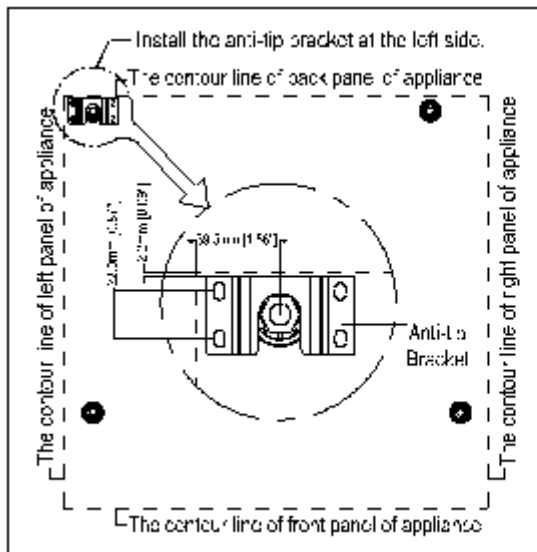

### Installing the Stainless Steel Handle

This appliance includes a stainless steel handle that is not required to operate the unit. To install the handle, follow the instructions below:

Locate the handle (1) over the mounting stub (3) of the door and using the supplied Allen key, tighten the securing grub screws (2) to fix the handle.

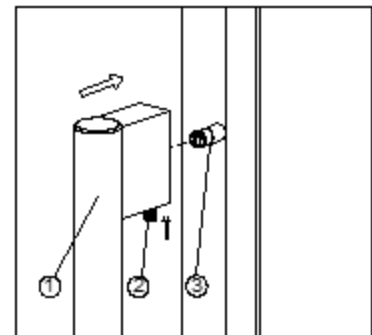



## OPERATING YOUR APPLIANCE

It is recommended that you install the appliance in a place where the ambient temperature is between 72° and 78°F (23° to 26°C). If the ambient temperature is above or below the recommended temperatures, the performance of the unit may be affected. For example, placing your unit in extremely cold or hot conditions may cause interior temperatures to fluctuate. The range of 36° to 43°F (2° to 6°C) may not be reached.

## Control Panel



### ON/OFF Power

- To turn the appliance off, press and hold the  key for 5 seconds until the temperature display goes out.
- To turn the appliance on, press and hold the  key for 1 second until the temperature display lights up.

**NOTE:** Pressing this key once can switch off the audible alarm when the alarm is on.

### Light

Turns the interior light ON and OFF.

### Up

Used to increase (warm) the set temperature by 1°C/1°F.

### Down

Used to decrease (cool) the set temperature by 1°C/1°F.

### °F/°C Selector

Select the temperature display setting in Fahrenheit or Celsius degrees. To change the temperature from Fahrenheit to Celsius or from Celsius to Fahrenheit, press and hold the **LIGHT** key for 5 seconds.

### Setting the Temperature Control

- You can set the temperature by touching the **UP** and **DOWN** symbols. When you push the two buttons for the first time, the LED readout will show the original temperature set previously. (The temperature preset at the factory is 38°F or 3°C.)
- The temperature you are setting will increase by one degree each time you touch the **UP** symbol, and will decrease by one degree each time you touch the **DOWN** symbol.
- The range of the temperature control is from 36°F to 43°F.
- To view the set temperature at any time, touch the **UP** or **DOWN** symbol. The set temperature will flash in the display window for 5 seconds. After 5 seconds, the temperature inside the unit will reappear in the display window.

#### **NOTES:**

- If the unit is unplugged, or power is lost or turned off, you must wait 3 to 5 minutes before restarting the unit. If you attempt to restart before this time delay, the unit will not start.
- When you use the unit for the first time or restart the unit after it has been shut off for a long time, there could be a few degrees variance between the temperature you select and the one indicated on the LED readout. This is normal and is due to the length of the activation time. There should not be a problem once the unit has been running for a few hours.

## Interior Light

- The interior light makes it easy to view your stored items and enhances the display of your collection. The **LIGHT** switch allows you to toggle between 2 modes of operation for the internal lights: functional (default) mode and showcase mode. If you are in functional (default) mode (also named Energy Saving Mode), the lights will turn on only when the door is open. If you are in showcase mode, the lights will be on whether or not the door is open.
- The unit is fitted with an LED light system and it is designed for extremely long life. It is not user serviceable. To change the LED light fitting, please contact the service department.

**NOTE:** Please use only the same type of LED light fittings originally provided by the manufacturer.

## Sabbath Mode

- Sabbath mode is available for the observance of certain religious holidays. This mode turns off the displays, interior light and audible alarms and prevents them from turning on again. Normal cooling operations will still take place.
- To initiate Sabbath mode, press the **POWER** and **LIGHT** keys at the same time for at least 5 seconds. The indicator light (the dot at the bottom right of the display) will flash four times and confirm the Sabbath mode is ON.
- Sabbath mode can be canceled by repeating the above process. The Sabbath mode will automatically turn off after 96 hours.

## Temperature Memory Function

In the event of a power interruption (power surge, breaker switch, etc.), the unit will remember the previous temperature settings, and when the power is recovered, the cabinet temperature will return to the same setting temperature as before power was lost.

## Temperature Alarm/Door Alarm

- An audible alarm sounds if the storage temperature is not cold enough. The temperature display flashes at the same time.
- The cause of the temperature being too high may be:
  - Warm items were placed inside
  - Too much warm ambient air flowed in when rearranging or removing contents
  - Power failure for some time
  - The appliance is faulty.
- The audible alarm is automatically silenced and the temperature display stops flashing when the temperature is sufficiently cold again.
- If the door has been left open for more than 60 seconds, the alarm will sound. Pressing the **POWER** key once will switch off the audible alarm.

## Shelves

To prevent damaging the door gasket, make sure to have the door all the way open when pulling the shelves out of the rail compartment.

- For easy access to the stored contents, you can pull the shelf approximately halfway out of the rail compartment. This unit was designed with a plastic post on each side of the shelf track to prevent shelf contents from falling.
- When removing the shelf from the inner rails, make sure to remove all shelf contents first. Then move the shelf to the position where the notches in the shelf are exactly aligned with the plastic posts and lift the shelf. In order to replace the shelf, repeat this procedure in reverse.

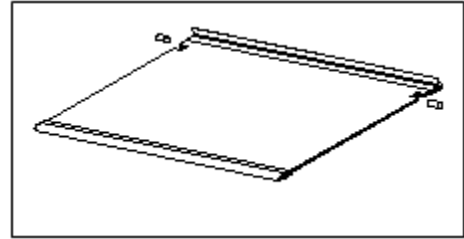

## Defrosting

- The unit defrosts automatically under normal operating conditions.
- The evaporator behind the rear wall of the unit defrosts automatically. The condensate collects in the drainage channel behind the rear wall of the unit, and flows through the drainage hole into the drip tray near the compressor where it evaporates.
- However, frost may accumulate on the evaporator if the unit is repeatedly opened in a high heat or high humidity location. If this frost pattern does not clear within 24 hours, your unit will require manual defrosting.

# CARE AND MAINTENANCE

## Cleaning your Beverage Merchandiser

*CAUTION: Failure to unplug the appliance during cleaning could result in electrical shock or other personal injury.*

- Turn off the power, unplug the appliance, and remove all items, including shelves.
- Wash the inside surfaces with a solution of warm water and baking soda (about 2 tablespoons of baking soda to a quart of water).
- Wash the shelves with a mild detergent solution.
- Wring excess water out of the sponge or cloth when cleaning the area where the controls are located, or any electrical parts.
- Wash the outside cabinet with warm water and mild liquid detergent. Rinse well and wipe dry with a clean soft cloth.
- Do not use steel wool or a steel brush on the stainless steel.

## Power Failure

Most power failures are corrected within a few hours and should not affect the temperature of your appliance if you minimize the number of times the door is opened. If the power is going to be off for a longer period of time, you need to take the proper steps to protect the contents.

## Vacations

- **Short vacations:** Leave the appliance operating during vacations of less than three weeks.
- **Long vacations:** If the appliance will not be used for several months, remove all items and turn off the appliance. Clean and dry the interior thoroughly. To prevent odor and mold growth, leave the door open slightly, blocking it open if necessary.

## Moving your Appliance

1. Remove all items.

2. Securely tape down all loose items (shelves) inside your appliance.
3. Turn the adjustable legs up to the base to avoid damage.
4. Tape the door shut.
5. Be sure the appliance stays secure in the upright position during transportation. Also, protect the outside of the appliance with a blanket or similar item.

### Energy-Saving Tips

- The appliance should be located in the coolest area of the room, away from heat-producing appliances and out of direct sunlight.
- Ensure that the unit is adequately ventilated. Never cover air vents.
- Do not keep the door open any longer than necessary.

## TROUBLESHOOTING

You can solve many common problems easily, saving you the cost of a possible service call. Try the suggestions below to see if you can solve the problem before calling the servicer.

PROBLEM	POSSIBLE CAUSE	REMEDY
Appliance does not operate.	<ul style="list-style-type: none"> <li>• Appliance is not connected to a power supply.</li> <li>• The appliance is turned off.</li> <li>• Tripped circuit breaker or blown fuse.</li> </ul>	<ul style="list-style-type: none"> <li>• Connect the appliance.</li> <li>• Switch on the appliance.</li> <li>• Switch on circuit breaker or replace fuse.</li> </ul>
Appliance is not cold enough.	<ul style="list-style-type: none"> <li>• The temperature is not set correctly.</li> <li>• The ambient temperature could require a lower set temperature setting.</li> <li>• The door was opened too often.</li> <li>• The door was not closed completely.</li> <li>• Door is not hermetically sealed.</li> <li>• The condenser is dirty.</li> <li>• The ventilation opening is blocked or too dusty.</li> </ul>	<ul style="list-style-type: none"> <li>• Check the set temperature.</li> <li>• Set a lower temperature.</li> <li>• Do not open the door more often than necessary.</li> <li>• Close door properly.</li> <li>• Check the door seal and clean or replace.</li> <li>• Clean the condenser when necessary.</li> <li>• Clear the obstructions and wipe off the dust.</li> </ul>
Appliance turns itself on and off frequently.	<ul style="list-style-type: none"> <li>• The room temperature is higher than average.</li> <li>• A large number of items have been added to the unit.</li> <li>• The door is opened too often.</li> <li>• The door is not closed completely.</li> <li>• The door gasket does not seal properly.</li> </ul>	<ul style="list-style-type: none"> <li>• Put the appliance in a cooler place.</li> <li>• Leave the appliance to work for a while until the set temperature has been reached.</li> <li>• Do not open the door more often than necessary.</li> <li>• Close door properly.</li> <li>• Check the door seal and clean or replace.</li> </ul>
The light does not work.	<ul style="list-style-type: none"> <li>• Appliance is not connected to a power supply.</li> </ul>	<ul style="list-style-type: none"> <li>• Connect the appliance.</li> </ul>

	<ul style="list-style-type: none"> <li>• Tripped circuit breaker or a blown fuse.</li> <li>• The light was switched off on the control panel.</li> </ul>	<ul style="list-style-type: none"> <li>• Switch on circuit breaker or replace fuse.</li> <li>• Switch on the light.</li> </ul>
Vibrations	<ul style="list-style-type: none"> <li>• The appliance is not properly leveled.</li> </ul>	<ul style="list-style-type: none"> <li>• Level the appliance with the adjustable feet.</li> </ul>
The appliance seems to make too much noise.	<p>A rattling noise may come from the flow of the refrigerant, which is normal. As each cycle ends, you may hear gurgling sounds caused by the flow of refrigerant in your appliance.</p> <p>If temperature fluctuations occur, the contraction and expansion of the inner walls may cause popping and crackling noises.</p>	
	<ul style="list-style-type: none"> <li>• The appliance is not properly leveled.</li> </ul>	<ul style="list-style-type: none"> <li>• Level the appliance with the adjustable feet.</li> </ul>
The door will not close properly.	<ul style="list-style-type: none"> <li>• The appliance is not properly leveled.</li> <li>• The gasket is dirty.</li> <li>• The shelves are out of position.</li> </ul>	<ul style="list-style-type: none"> <li>• Level the appliance with the adjustable feet.</li> <li>• Clean the door gasket.</li> <li>• Check the shelves and refit correctly.</li> </ul>
Display “E0”, “E1”, “E2”, “E3”, “E4”, “E5”, “E6” or “E7”.	<ul style="list-style-type: none"> <li>• “E0” indicates a communication error for 3- zone models.</li> <li>• “E1” or “E2” indicates that the air temperature sensor has failed.</li> <li>• “E3” or “E4” indicates that the defrost sensor in the evaporator has failed.</li> <li>• “E5” indicates a defrost heater failure.</li> <li>• “E6” indicates a solenoid valve failure.</li> <li>• “E7” indicates a door switch failure.</li> </ul>	<ul style="list-style-type: none"> <li>• Call for service.</li> </ul>
The alarm sounds and the temperature display flashes.	<ul style="list-style-type: none"> <li>• Has the appliance door been open for longer than 60 seconds? If not, then the temperature has risen higher or fallen lower than the set temperature. This could be due to: <ul style="list-style-type: none"> <li>- The appliance door has been opened too often.</li> <li>- The ventilation opening is covered or too dusty.</li> <li>- A lengthy interruption to the power supply.</li> <li>- A large number of items have been added to the unit.</li> </ul> </li> </ul>	<ul style="list-style-type: none"> <li>• If yes, close the door.</li> <li>- Do not open the door more often than necessary.</li> <li>- Clear the obstructions and wipe off the dust.</li> <li>- Let the appliance work for a while until the set temperature has been reached.</li> </ul>
The icon “--” is lit up and flashing in the temperature display.	<ul style="list-style-type: none"> <li>• The display temperature is out of range.</li> </ul>	<ul style="list-style-type: none"> <li>• Only temperatures within the range 0~99°F/-9~37°C can be displayed. If the temperature is not within this range, the icon “--” will be displayed instead. This is normal.</li> </ul>

## LIMITED WARRANTY

### **ONE-YEAR LIMITED WARRANTY**

Within the 48 contiguous United States, for one year from the date of purchase, when this appliance is operated and maintained according to instructions attached to or furnished with the product, warrantor will pay for factory-specified parts and repair labor to correct defects in materials or workmanship. Service must be provided by a designated service company. Outside the 48 states, all parts are warranted for one year from manufacturing defects. Plastic parts, shelves and cabinets are warranted to be manufactured to commercially acceptable standards, and are not covered from damage during handling or breakage.

### **5-YEAR COMPRESSOR WARRANTY**

1. The compressor is covered for 5 years.
2. Replacement does not include labor.

#### ***ITEMS WARRANTOR WILL NOT PAY FOR:***

1. Service calls to correct the installation of your appliance, to instruct you how to use your appliance, to replace or repair fuses or to correct wiring or plumbing.
2. Service calls to repair or replace appliance light bulbs or broken shelves. Consumable parts (such as filters) are excluded from warranty coverage.
3. Damage resulting from accident, alteration, misuse, abuse, fire, flood, acts of God, improper installation, installation not in accordance with electrical or plumbing codes, or use of products not approved by warrantor.
4. Replacement parts or repair labor costs for units operated outside the United States.
5. Repairs to parts or systems resulting from unauthorized modifications made to the appliance.
6. The removal and reinstallation of your appliance if it is installed in an inaccessible location or is not installed in accordance with published installation instructions.

### **DISCLAIMER OF IMPLIED WARRANTIES; LIMITATION OF REMEDIES**

CUSTOMER'S SOLE AND EXCLUSIVE REMEDY UNDER THIS LIMITED WARRANTY SHALL BE PRODUCT REPAIR AS PROVIDED HEREIN. IMPLIED WARRANTIES, INCLUDING WARRANTIES OF MERCHANTABILITY OR FITNESS FOR A PARTICULAR PURPOSE, ARE LIMITED TO ONE YEAR. WARRANTOR SHALL NOT BE LIABLE FOR INCIDENTAL OR CONSEQUENTIAL DAMAGES. SOME STATES DO NOT ALLOW THE EXCLUSION OR LIMITATION OF INCIDENTAL OR CONSEQUENTIAL DAMAGES, OR LIMITATIONS ON THE DURATION OF IMPLIED WARRANTIES OF MERCHANTABILITY OR FITNESS, SO THESE EXCLUSIONS OR LIMITATIONS MAY NOT APPLY TO YOU. THIS WARRANTY GIVES YOU SPECIFIC LEGAL RIGHTS AND YOU MAY ALSO HAVE OTHER RIGHTS, WHICH VARY FROM STATE TO STATE.



**WARNING: This product can expose you to chemicals including Nickel (Metallic) which is known to the State of California to cause cancer.**

For more information go to [www.P65Warnings.ca.gov](http://www.P65Warnings.ca.gov)

Note: Nickel is a component in all stainless steel and some other metal components.

**FELIX STORCH, INC.**  
770 Garrison Avenue  
Bronx, NY 10474  
Phone: (718) 893-3900  
Fax: (844) 478-8799  
[www.summitappliance.com](http://www.summitappliance.com)



SUMMIT CLASSIC COLLECTION

For parts and accessory ordering,  
troubleshooting and helpful hints, visit:  
[www.summitappliance.com/support](http://www.summitappliance.com/support)

Revised July 2020