

Whirlpool

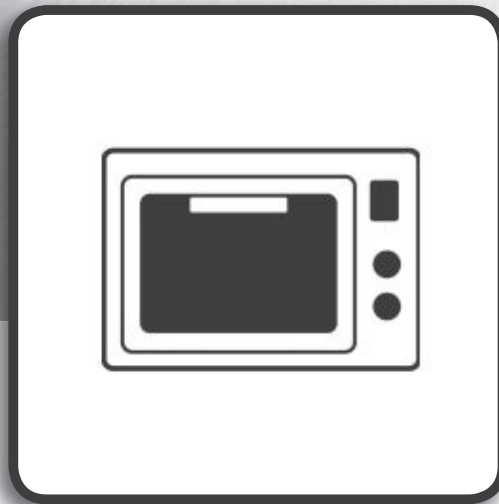

Health & Safety, Use & Care, Installation Guide and Online Warranty Registration Information

Model : MWP329TBA, MWP329TSA, MWP329TMA



www.whirlpool.com.au
www.whirlpool.co.nz

Table of Contents

■ General Preparation and Advice before Use

	Page
Important Safety Information	1
Precautions before First Use	1
Precautions and Advice	1-2
Mounting the Appliance	3
Earthing Instructions	3
Appliance and Accessories Chart	4-5
Water tank and drip tray	6
Control Panel	6
Control Panel – Basic Functions	7
Control Panel – Major Features	8
Control Panel – Description of Major Features	9-11
Use and Cooking Tips	12
Recommended Recipes	13-14

■ Operation Instructions

	Page
Setting the Clock	15
Microwave Mode	16
Steam Mode	17
Steam + Microwave Mode	18
Upper Grill Mode	19
Upper Grill + Microwave Mode	20
Bottom Grill Mode	21
Conventional Bake Mode	22
Conventional Bake + Microwave Mode	23
Convection Mode	24
Turbo Convection Mode	25
Turbo Convection + Microwave Mode	26
Convection + Steam Mode	27
Convection + Steam + Microwave Mode	28

	Page
Keep Warm Mode	29
Drying Fruit Mode	30
Slow Cook Mode	31
Proving Mode	32
Bread Reheat Mode	33
Defrost Mode	34
Preheat Mode	35-36
Air Fry Mode	37
Cavity Drying Mode	38
Descaling Mode	39-40
DIY Cooking	41-42
Adjust or Increase the Cooking Time	43-44
during / After Cooking is Completed	
Preset Function	45-46
Auto Menu	47-50
Residual Heat Indicator	51
Child Lock	51

■ Cleaning and Maintenance

	Page
Cleaning and Maintenance	52-54

■ Others

	Page
Troubleshooting	55-56
Product Specifications	57

General Preparation and Advice Before Use

■ Important Safety Information

This manual contains important information on safety, use and maintenance of the product. Please read the manual carefully and keep it in an easily accessible place for future reference.

■ Precautions before First Use

1. Two or more people are required to install or move this appliance as it is heavy. It must be securely placed on a firm and level surface. Failure to do so can cause physical injuries or damage to the appliance.
2. This appliance is designed solely for indoor and domestic use. Follow the cooking instructions indicated in the manual. Do not use this appliance for outdoor, commercial or any other purposes.
3. Check that the voltage on the rating label corresponds to the voltage in your home.
4. Ensure that the appliance is not damaged. Do not operate the appliance if it has a damaged mains cord or plug. If it is not working properly, or it has been damaged or dropped. Please contact Whirlpool Customer Services.
5. Do not immerse the power cord or plug in water. Keep the power cord away from hot surfaces to avoid electrical shock, fire or other accidents.
6. This steam microwave oven is designed for free standing installation. Do not install as a built-in appliance.
7. Allow adequate ventilation space on all sides and do not place any object on top. Keep a minimum distance of 5cm between the steam microwave oven and any overhead wall cabinet; and a minimum distance of 1cm between both sides of the appliance and the walls.
8. To avoid damage to the appliance, do not block the ventilation vent.
9. Run the "Steam mode" at 110°C for 30 minutes to clean and sterilize the combi steamer before first use.
10. The manufacturer disclaims all liability for faults arising from improper use of this appliance.
11. Steam is emitted from the top ventilation vent. Blocking the outlets will result in damage to the steam microwave oven.

12. Use heat resistant utensils for cooking, such as heat resistant glass and heat resistant plastic. Non-heat resistant containers should not be used with steam microwave oven. For steaming functions, container with heat resistant > 120°C should be used. For convection functions, container with heat resistant > 250°C should be used.
13. Odour will be emitted from the cavity when using different baking functions for the first time. It is normal.

■ Precautions and Advice

1. Stop using the steam microwave oven and contact Whirlpool Customer Service immediately if the door or door seal is damaged.
2. If the power cord is damaged, it must be replaced by the manufacturer, its service agent or similarly qualified persons in order to avoid a hazard.
3. To avoid fire hazard or explosion, do not heat or use flammable materials in or near the appliance.
4. To avoid fire hazard, do not use the appliance to dry cloth, paper, spices, herbs, wood, flowers or other flammable objects.
5. Overcooking food poses a fire hazard.
6. Never leave the appliance unattended during use, particularly when cooking with paper, plastic or other flammable materials. Paper may catch fire or get burned and some plastic materials may melt when heating up food with the appliance. If any object inside or outside the appliance is ignited or emits smoke, close the appliance door and switch off the combi steamer. Disconnect the power supply and the socket with circuit leakage breaker.
7. This steam microwave oven is specifically designed to heat or cook food. It is not designed for industrial or laboratory used.
8. Children should be supervised to ensure that they do not play with the appliance.
9. This steam microwave oven is not intended for use by persons (including children) with reduced physical, sensory or mental capabilities, or lack of experience and knowledge, unless under supervision or instruction of a person responsible for their safety.

General Preparation and Advice Before Use

- After cooking, clean the steam microwave oven only when it has completely cooled down. Wipe away any food debris or waste inside the oven. Top of the oven cavity gets burned easily and care should be taken to keep it clean. For best cooking results, keep the combi steamer completely dry by opening the door every time after cooking.
- Use oven gloves to take food and containers out of the appliance to avoid burning.
- To avoid a hazard, do not touch the upper heater in the oven when using the appliance.
- Do not use the steam microwave oven for storage.
- After heating food or beverages in nursing bottles or infant food cans, always stir and check the temperature before serving. This will ensure that heat is evenly distributed and the risk of scalding or burns can be avoided.
- Wait 10-15 minutes after each program before continuing to another mode.
- Steam will be rapidly evaporated and not easily be seen if the oven cavity at the high temperature or just finished all convection modes. It is normal.
- Do not touch the door and door frame when using the appliance.
- Fill the water tank with tap water, drinking water or distilled water up to the MAX mark (maximum level). Insert the water tank into the appliance completely.
- If the water tank is cracked or damaged, stop using it to avoid power leakage or electrical shock caused by water leakage.
- For hygienic reasons and prevent condensation inside the combi steamer. Empty the water tank and keep the combi steamer completely dry every time after cooking.
- If the water tank is cracked or damaged, stop using it to avoid power leakage or electrical shock caused by water leakage.
- Do not fill the water tank with any liquids other than water (except descaler).
- To avoid condensation and oven temperature drops, do not open the oven door when cooking with "Steam" mode unless it is absolutely necessary. If you have opened the oven door, extend the cooking time accordingly.
- If it is necessary to open the oven door to turn the food or for other purposes during cooking, keep a distance from the oven door (particularly the face) to prevent scalding.
- All maintenance and repairs should be carried out by a similarly qualified person. It is dangerous to fix the appliance by anyone except a similarly qualified person. Never dismantle, repair or modify the appliance by yourself.
- Accessible parts of the appliance may become hot during use. Young children should be kept away.
- When the steam microwave oven is plugged, never touch the appliance, the power cord or plug with wet hands or other wet body parts.
- Do not place or hang any objects on the oven door or the door handle. It may affect the door's opening and closing or damage the door hinges.
- After cooking ends, the electric fan will continue running for a certain period of time to cool down the cavity.
- The steam microwave oven and its parts should be kept clean. Failure to do so will result in deterioration of the appliance surface and affect its life cycle. It may also cause danger.
- Remove the power supply plug before cleaning. Do not use corrosive cleaners as they may cause damage or corrosion.
- Water in the water tank will be heated up and discharged to the drip tray during "Descaling Mode". Do not allow children to touch or go near the combi steamer.
- Clean dust from the power supply plug on a regular basis. If the product will not be used for a long time, remove the power supply cord. Do not pull the power supply cord but hold the plug to remove it.
- Never leave the steam microwave oven in operation unattended.
- Overheated fat and oil catch fire easily. Except grilling meat, heating oil during cooking is dangerous. Such practice should never be allowed.
- Maximum load for the oven door is 7kg. To avoid damaging the steam microwave oven, do not place food or heavy objects on the oven door.

General Preparation and Advice Before Use

■ Mounting the Appliance

1. Good ventilation must be ensured around the steam microwave oven. Do not place any objects on top of the appliance and allow a minimum distance of 30 cm between the microwave steam oven and any overhead wall cabinet. Keep a minimum distance of 5 cm between both sides of the appliance and walls. Appliance back can be closed to the wall.

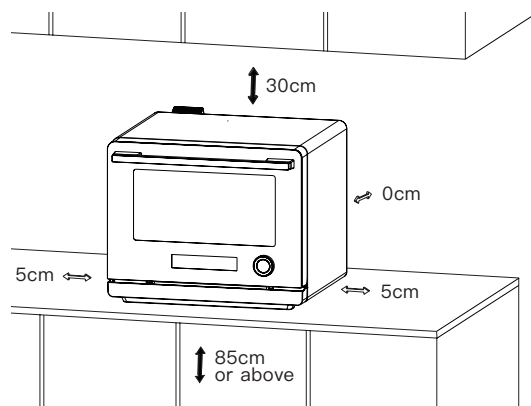

2. To prevent fire, do not block the air outlet and steam outlet. Maintain the product regularly and prevent foreign matter and dust from blocking the air outlet and steam outlet.
3. Do not put the appliance in a hot or humid place, such as gas stove, electrified areas or sink.
4. This appliance must be placed on a firm and stable surface.

■ Earthing Instructions

This appliance must be earthed. In case of electric leakage, the ground can provide a current loop to avoid electric shock. The power supply plug that comes with this appliance must be inserted into a single-phase-bipolar socket with grounding.

General Preparation and Advice Before Use

■ Appliance and Accessories Chart

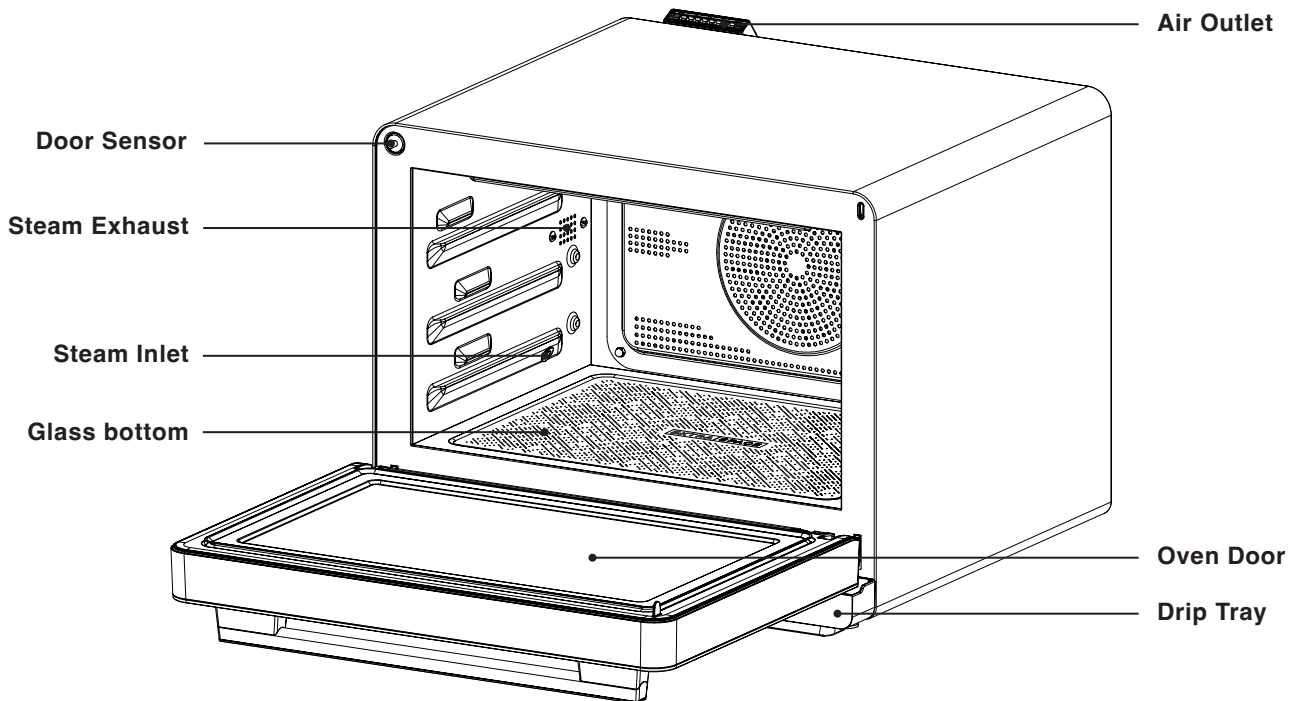

- **Air Outlet:** To exhaust excessive steam from the cavity
- **Steam Exhaust:** To discharge excess steam from the cavity
- **Steam Inlet:** To release steam into the cavity
- **Oven Door:**
 1. Make sure the door is closed before starting to cook.
 2. The microwave steam oven will pause if you open the oven door during cooking. The selected mode will continue automatically once the door is closed.
- **Drip Tray:** To collect excess water when the door is open.
- **Door Sensor:** To sense the door closed.
- **Glass bottom:** Place the container with food on the glass bottom directly when using microwave function to cook.

General Preparation and Advice Before Use

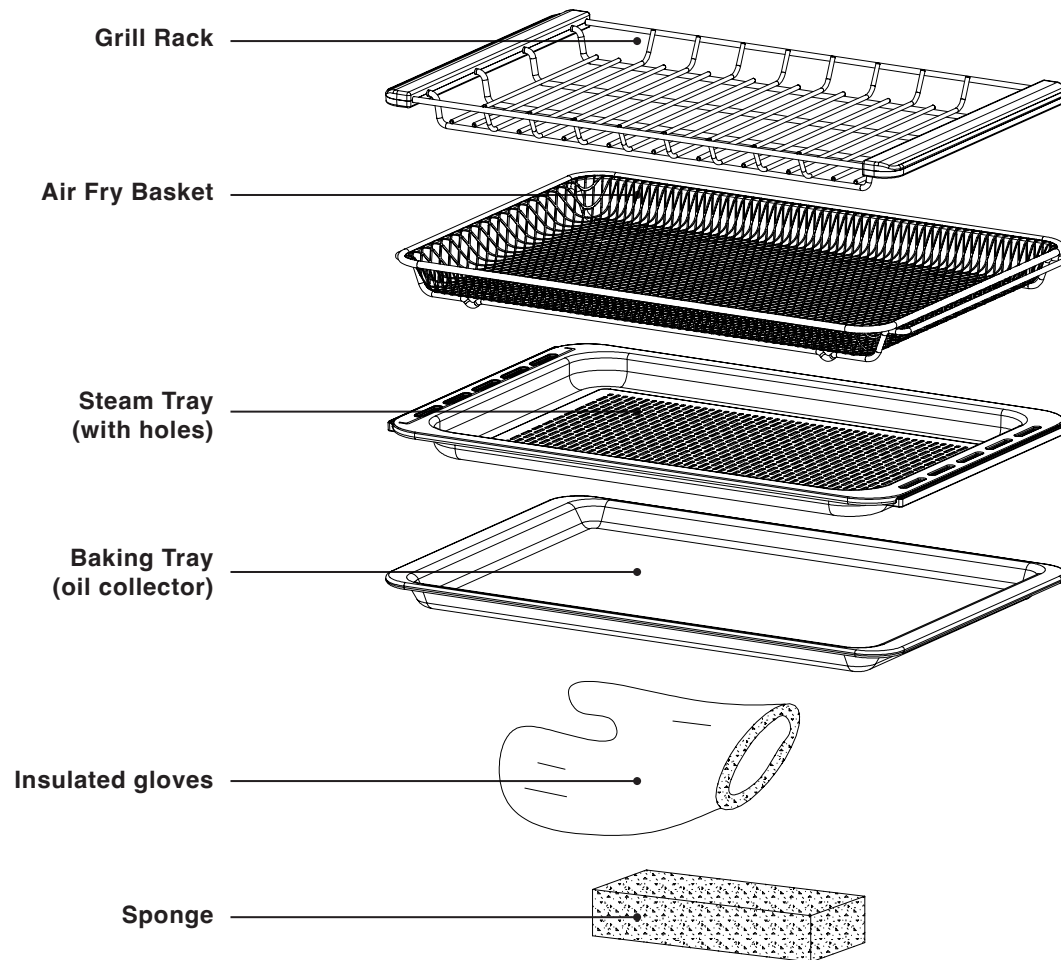

1. Grill Rack

Mainly for modes that cook with the heater, such as “Grill”, “Convection” or “Forced Air” modes.

2. Air Fry Basket

For use under “Air Fry” mode. Do not use it for cooking mode with microwave.

3. Steam Tray (with holes)

Mainly for the “Steam” mode. Designed with vent holes, it can also be used for other cooking modes.

4. Baking Tray (oil collector)

Mainly for the “Forced Air + Steam”, “Convection + Steam” or “Forced Air” mode. It can also be placed at the bottom level to collect dripping oil when cooking meat.

5. Insulated gloves

To take food or rack out from the microwave steam oven.

6. Sponge

To remove condensation inside the oven.

General Preparation and Advice Before Use

Water tank and drip tray

Water tank:
holds clean water
to produce steam

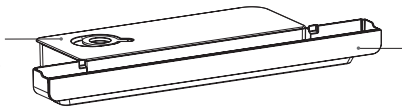

Drip tray: collect excess water
when the door is open.

Installation:
Removing / installation method

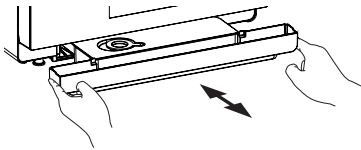

Water tank may contain remaining water, please be careful when taking it out.
When installing, make sure the water tank cover is closed tightly, push the water tank all the way in, and ensure the water tank is installed in place; Tilt may cause water to overflow, please keep it horizontal at all times.

How to fill water:

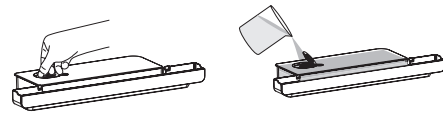

Before using steam cooking, please open the round silicone lid and pour clean water or distilled water until the water tank is full.

Notice!





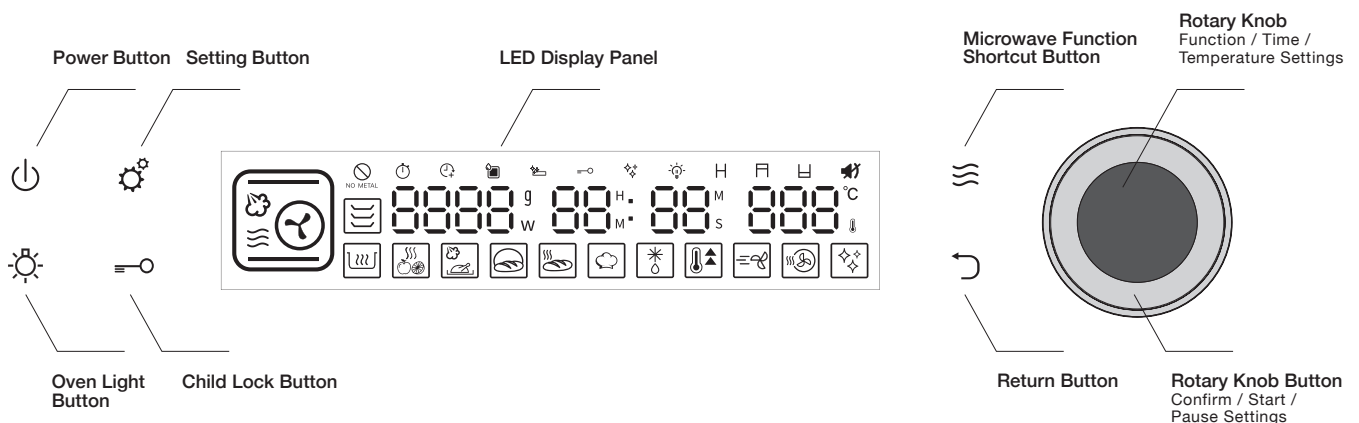

- For first time use or when you have not use steam function to cook for a long time, please clean by running the steam mode (110°C) before cooking;
- Please clean the water tank and drip tray from time to time;
- Please use pure water or distilled water for cooking, otherwise scale deposit may occur;
- When using steam function to cook, be sure to fill the water tank with water and ensure the water tank is properly installed. If there is too little water or the water tank is not installed properly, “please add water” icon will appear and prompt during steam cooking and cooking will be suspended.

Control Panel

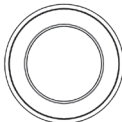

General Preparation and Advice Before Use

■ Control Panel – Basic Functions

Icon	Function Descriptions
	<p>Rotary Knob Function / Time / Temperature Settings</p> <p>Rotary Knob Button Confirm / Start / Pause Settings</p>
	<p>Setting/ Auto Menu Button</p> <ol style="list-style-type: none"> 1. Under Standby mode, press once to enter auto menu function and select recipe; 2. Under Standby mode, hold the setting button for 3 seconds to enter clock setting; 3. Under “DIY function”, press setting button to enter next cooking function setting; 4. While setting cooking time/ temperature, hold the setting button for 3 seconds to enter “Preset function” 5. When cooking in progress, hold the setting button for 3 seconds to check cavity actual temperature 6. In pause mode, press setting button to adjust cooking time and temperature
	<p>Return Button</p> <ol style="list-style-type: none"> 1. Return / Reset; 2. Press the return button during setting to go back to the previous screen or reset cooking modes or cooking time. 3. Mute Mode To activate mute mode: In standby mode, press and hold the button for 3 seconds to activate the mute mode. The mute icon lights up on the display panel. To release mute mode: In standby mode, press and hold the return button for 3 seconds while it is activated.
	<p>Oven Light Button</p> <ol style="list-style-type: none"> 1. Touch once to switch the light on for 3 minutes. The oven light icon will not light up on the display panel. 2. During cooking in process, press and hold for 3 seconds, the oven light will stay on. The oven light icon will light up on the display panel. Press and hold for 3 seconds again to switch off the oven light. 3. At standby mode, press and hold for 3 seconds, the oven light will stay on for 5 minutes. The oven light icon will light up on the display panel. If there is no operation in 5 minutes, the oven will switch to standby mode, oven light will be switched off automatically. 4. The oven light will light up for 3 minutes when the door is open.
	<p>Child Lock Button</p> <p>Press and hold the button for 3 seconds to activate / release the child lock.</p> <p>To activate child lock: Press and hold the button for 3 seconds. The control panel will be locked and no operation is possible. The child lock icon lights up on the display panel.</p> <p>To release child lock: To release, press and hold the child lock button for 3 seconds while it is activated.</p>
	<p>Power Button</p> <p>After 5 minutes without operation after activate the combi steamer, including opening or closing the oven door. Combi steamer will automatically enter to power-saving mode, display panel goes out. In power-saving mode, only power button is operable. To release child lock: To release, press and hold the child lock button for 3 seconds while it is activated.</p>
	<p>Microwave Shortcut Button</p> <ol style="list-style-type: none"> 1. Press the microwave shortcut button to enter microwave function setting under standby mode or other setting mode 2. Press and hold the microwave shortcut button for 3 seconds for Jet Start function (cook 30 seconds with full power microwave)

General Preparation and Advice Before Use



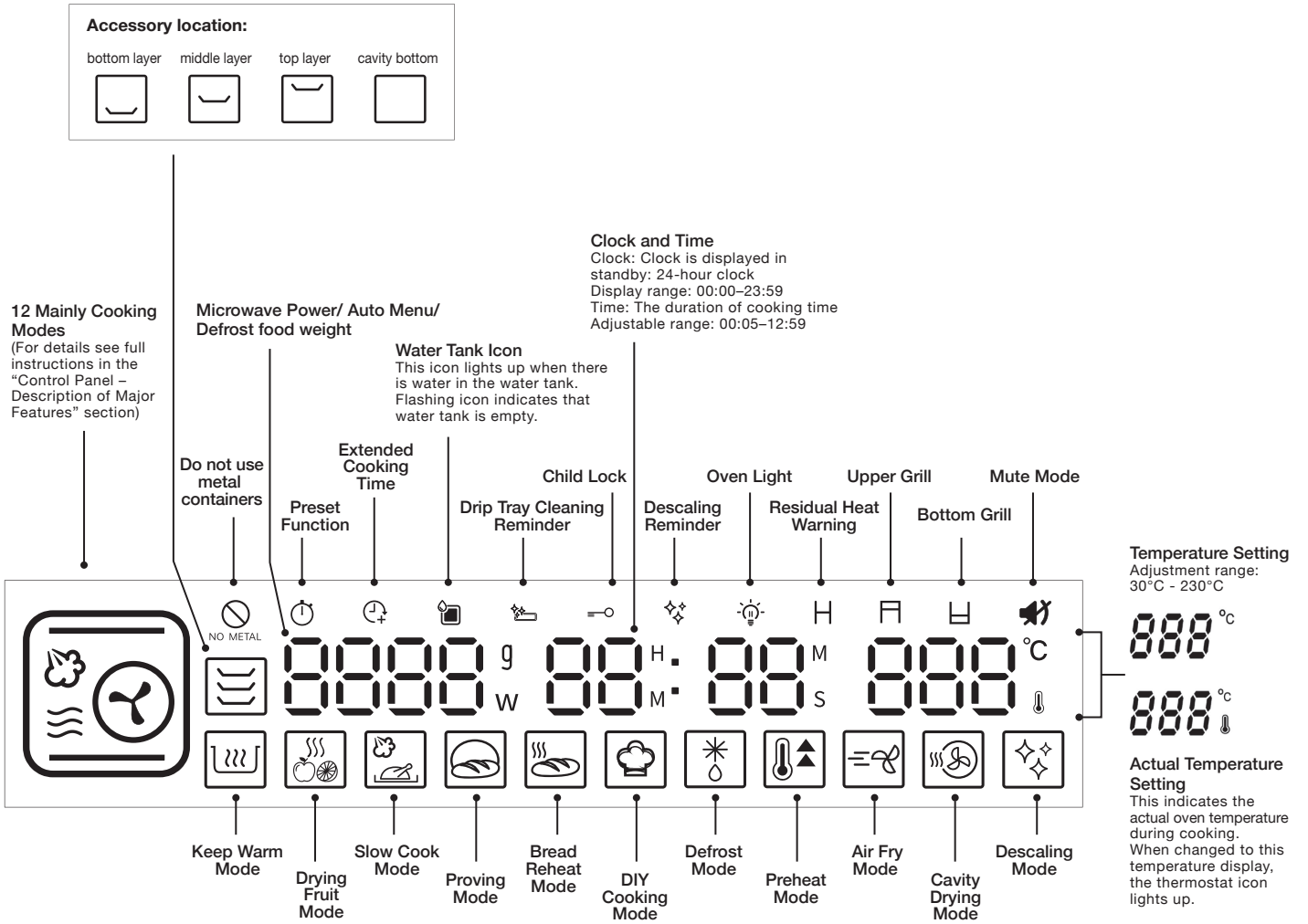







Control Panel – Major Features





General Preparation and Advice Before Use

■ Control Panel – Description of Major Features

Major Cooking Mode











Icon	Mode	Function Descriptions	Default Time/ Temperature	Time/ Temperature Selection Range
	Steam	Steam cooking preserves the original taste, nutrients and color of food cooked. It is suitable for steaming vegetables, meat and seafood or braising soup.	20 mins / 100°C	Time: 5-419 mins (maximum 6 hours 59 mins) Temperature: 50-110°C
	Steam + Microwave	Steam cooking preserves the original taste, nutrients and color of food cooked. Adding microwave to cooking process can shorten cooking time. It is suitable for long hour steaming food, such as, braising soup and meat.	15 mins / 100°C	Time: 5-419 mins (maximum 6 hours 59 mins) Temperature: 50-110°C
	Upper Grill	Suitable for roasting baking - food or at a final stage of roasting or baking. It helps browning the surface of your dish.	25 mins / 110°C	Time: 5-239 mins (maximum 3 hours 59 mins) Temperature: 50-230°C
	Upper Grill + Microwave	Suitable for roasting baking food, cooking time can be shorten with microwave.	20 mins / 100°C	Time: 5-239 mins (maximum 3 hours 59 mins) Temperature: 50-230°C
	Bottom Grill	Suitable for baking the final stage or for food that needs to be cooked from the bottom periodically during cooking. e.g. pizzas, macaroon.	20 mins / 100°C	Time: 5-239 mins (maximum 3 hours 59 mins) Temperature: 50-230°C
	Conventional Bake	Traditional single-level baking and grilling mode. Heat is released from the top and bottom to get food baked evenly. Suitable for cooking meat, fish, bread and cookies, pastries and desserts etc., and particularly suitable for cakes with moist ingredients at the top.	30 mins / 180°C	Time: 5-239 mins (maximum 3 hours 59 mins) Temperature: 50-230°C
	Conventional Bake + Microwave	Traditional single-level baking and grilling mode. Heat is released from the top and bottom to get food baked evenly and quickly with microwave. Suitable for cooking meat, bread, pastries and desserts etc.	25 mins / 180°C	Time: 5-239 mins (maximum 3 hours 59 mins) Temperature: 50-230°C
	Convection	The upper and bottom heater and rear fan operate simultaneously in this mode. Suitable for all baking dishes, such as meat, seafood, pizzas, bread and cookies, pastries and desserts.	20 mins / 160°C	Time: 5-239 mins (maximum 3 hours 59 mins) Temperature: 80-230°C
	Turbo Convection	Cooking time is shortened in this mode to bake and roast food quickly. It is suitable for baking large meat and cakes.	25 mins / 180°C	Time: 5-239 mins (maximum 3 hours 59 mins) Temperature: 80-230°C
	Turbo Convection + Microwave	With microwave support, cooking time can be shortened further in this mode to bake and roast food quickly. It is suitable for baking large meat.	15 mins / 180°C	Time: 5-239 mins (maximum 3 hours 59 mins) Temperature: 50-230°C

General Preparation and Advice Before Use

Icon	Mode	Function Descriptions	Default Time/ Temperature	Time/ Temperature Selection Range
	Convection + Steam	This mode combines upper, lower heat, hot air and steam cooking. It is a perfect all-in-one combination cooking. Adding steam during the cooking process can prevent moisture loss during high temperature cooking. Suitable for cooking all types of food, such as large cuts of meat or baking moist cakes.	20 mins / 180°C	Time: 5-419 mins (maximum 6 hours 59 mins) Temperature: 100-230°C
	Convection + Steam + Microwave	This mode combines upper, lower heat, hot air, steam and microwave cooking. It is a perfect all-in-one combination cooking. Adding steam during the cooking process can prevent moisture loss during high temperature cooking, while microwave can shorten the total cooking time. Especially suitable for cooking large portion of food, such as large cuts of meat.	15 mins / 180°C	Time: 5-239 mins (maximum 3 hours 59 mins) Temperature: 80-230°C
	Microwave	Microwaves can heat food quickly and are suitable for reheating food.	30 sec / 900W	10 sec - 90 mins 55 sec 100 W - 900 W

General Preparation and Advice Before Use

Cooking Functions

Icon	Mode	Function Descriptions	Default Time/ Temperature	Time/ Temperature Selection Range
	Keep Warm	Keeping food warm with hot air. Suitable for keeping cooked dishes warm.	20 minutes / 55°C	Time: 5-419 mins (maximum 6 hours 59 mins) Temperature: 50-110°C
	Drying Fruit	Food is dehydrated with hot air in low heat. Suitable for preparing dried fruit and sliced vegetable or meat jerkies.	20 mins / 60°C	Time: 5-779 mins (maximum 12 hours 59 mins) Temperature: 40-90°C
	Slow Cook	Steam is injected to maintain temperature inside the oven for slow cooking. Low temperature is used, meat and seafood can be preserved the original flavor without overcooking. Food can be placed in vacuum bags for this mode.	60 mins / 60°C	Time: 60-779 mins (maximum 12 hours 59 mins) Temperature: 50-90°C
	Proving	This mode works with steam to ensure stable and humidity inside the oven. It allows doughs (for pizzas or bread) to rise quicker in a stable environment, and it used for fermenting pizzas or bread.	40 mins / 35°C	Time: 5-779 mins (maximum 12 hours 59 mins) Temperature: 25-50°C
	Bread Reheat	Bread is reheated at a regulated temperature and steam is added to reheat bread that tastes just like freshly-baked. Two heating modes are available: Room temperature bread and refrigerated bread.	10 mins / 180°C	Time: 5-59 mins Temperature: Cannot be adjusted
	Defrost	Defrost chilled or frozen food.	7 mins 40 sec / 500g	100g - 2000g
	Preheat – Steam	Oven is heated to preset temperature by steam.	Present time / 100°C	Temperature: 50-110°C
	Preheat – Baking	Oven is heated to preset temperature by baking function.	Present time / 180°C	Temperature: 100-230°C
	Air Fry	A fan is used to circulate heat in the oven cavity to create convection, allowing the food to be baked in a shorter time to create a crispy effect. It is suitable for food that needs to be air-fried or for baking larger meats and pastries.	25 mins / 180°C	Time: 5-239 mins (maximum 3 hours 59 mins) Temperature: 80-230°C
	Cavity Drying	In this mode, the oven is heated to a high temperature so any excessive moisture and steam are evaporated. This function is used for drying the oven after any steam cooking modes.	15 mins / 180°C	Time: Cannot be adjusted Temperature: Cannot be adjusted
	Descaling	Descaling icon will be on once combi steamer has reached 100 hours steam related cooking time to remind the user to run descaling programme mode. A descaler is required.	60 mins	Time: Cannot be adjusted Temperature: Cannot be adjusted
	DIY Cooking	Complete a variety of different cooking function combination at one time automatically.		





























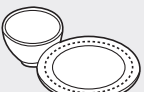

General Preparation and Advice Before Use

■ Use and Cooking Tips



1. Minimum time setting is 5 minutes for all cooking modes (Except the "Increase the Cooking Time after Cooking is Completed" function).
2. After cooking is done, the fan will continue to work for 3 minutes for cool down purpose. This is normal.
3. The combi steamer will pause automatically if you open the oven door during cooking. Cooking will continue automatically at the set time and temperature once the door is closed.
4. Take extra care when removing container from the oven after heating, like soup, sauce or beverage. To prevent over boiling, following steps should be taken in cooking liquid.
 - (a) Do not over-heat liquid food. Boiling liquid may splash out and cause scalding when you remove it from the combi steamer.
 - (b) When heating up liquid food, make sure the container is at most 80% full because a small amount of liquid may splash out suddenly when boiled.
 - (c) Stir the liquid before and during heating.
 - (d) Allow the food to stand inside the combi steamer for a while when heating is done. Stir it gently before removing.
 - (e) When using a feeding bottle or heating baby food, stir or shake the food and check the temperature before feeding to avoid burning.
5. Only use a thermometer designed for ovens to check food temperature during cooking, if necessary. If longer cooking time is required, put the food back into the combi steamer to continue cooking.
6. To avoid overheating or over-browning, it is recommended to take the food out when roasting or steaming is finished.
7. To maintain constant temperature during cooking, do not open the oven door unless it is necessary. To avoid affecting oven temperature, do not open the oven door to check food during cooking. If you have opened the oven door, extend the cooking time accordingly.
8. To ensure even browning and cooking, adjust or turn the food's position or direction of the steam or grill plate halfway during heating.

General Preparation and Advice Before Use

■ Recommended Recipes

Type of container	Microwave	Combi (with steam, microwave or grill)	Steam	Grill/ Convection
Heat-resistant glass container 	 When cooking food which will produce high temperatures, e.g. jam, please use super heat-resistant glass containers that are resistant to sudden cold and sudden heat.	 When cooking food which will produce high temperatures, e.g. jam, please use super heat-resistant glass containers that are resistant to sudden cold and sudden heat.		
Non heat-resistant glass container 	 Cut glass and tempered glass cannot be used either.	 Cut glass and tempered glass cannot be used either.		
Heat-resistant plastic container 	 Please use containers marked with "Suitable for Microwave". Note 1: Please note that some container lids have poor heat resistance. Note 2: It is prohibited to use lids with strong sealing properties. Note 3: Foods containing high amounts of oil and sugar are prone to high heat, so heat-resistant plastic containers cannot be used.	 Please use containers marked with "Suitable for Microwave". Note 1: Please note that some container lids have poor heat resistance. Note 2: It is prohibited to use lids with strong sealing properties. Note 3: Foods containing high amounts of oil and sugar are prone to high heat, so heat-resistant plastic containers cannot be used.		
Non heat-resistant plastic container 	 Containers made of materials (such as polyethylene, melamine, phenol, urea resin, etc.) are easily affected by microwaves and deteriorate, so containers made of these materials cannot be used.	 Containers made of materials (such as polyethylene, melamine, phenol, urea resin, etc.) are easily affected by microwaves and deteriorate, so containers made of these materials cannot be used.		
Ceramic and porcelain 	 Note: Containers decorated with gold, silver or color painting may cause color peeling, sparking, etc.	 Note: Containers decorated with gold, silver or color painting may cause color peeling, sparking, etc.		
Lacquerware 	 Paint may peel off or break.	 Paint may peel off or break.		

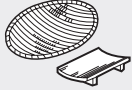
General Preparation and Advice Before Use

Type of container	Microwave	Combi (with steam, microwave or grill)	Steam	Grill/ Convection
Metal containers, such as aluminum 	X	X	✓	✓ Note: If the handle of a metal container is made of resin material, it cannot be used.
Wood / bamboo / paper containers 	X Prone to burning.	X Prone to burning.	X Note: Wooden, bamboo containers and thermal processed paper products can be used.	X Note: When the cooking temperature is 230 °C or below, paper containers with heat-resistant processing can be used.
Microwave cling film 	✓ It is recommended to use plastic wrap with a heat resistance of 140°C. Note: Cannot be used for cooking oily foods.	X	X	X Plastic wrap will melt when exposed to high temperatures.
Aluminum foil (household tin foil) 	X	X	✓	✓

When using the microwave function, you can use a microwave - safe container and place it directly on the cavity glass bottom for cooking.

- * It is prohibited to use metal utensils, otherwise sparks may be generated and cause malfunction.
- * Place the food directly in the center of the oven cavity. If there is more than one plate of food, please refer to the following placement method for optimal result (the food is concentrated in the center)

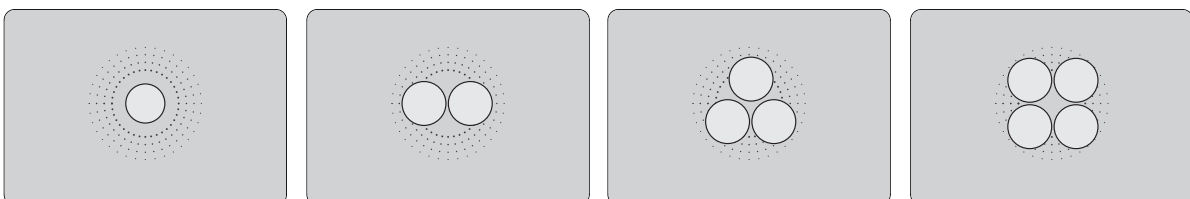

Operation Instructions

■ Setting the Clock

When the appliance is first powered on, it will beep and returned to standby mode. The default clock display is 12:00. The display panel lights up completely.



The steam microwave oven returned to energy saving mode if no button is pressed or door is opened for 5 minutes. Under energy saving mode, display will be turned off, only the power button can be used. Press the power button to exit the energy saving mode and back to the startup screen.

Example: Set the clock to the current time 13:20.

Steps:

1. On the standby screen, press and hold the setting button  for 3 seconds. The hour digits flash. (as shown in the diagram below)



2. Set the hour by turning the knob. When the hour reaches 13, press the knob to confirm. (as shown in the diagram below) The display will change to the minute setting automatically. The minute digits flash.



3. Set the minute by turning the knob. When the minute reaches 20, press the knob to confirm. (as shown in the diagram below)



4. Time setting is complete. (as shown in the diagram below)



Important: If no action is taken within 5 minutes during the setting process, all settings will be cancelled and the display will return to the standby screen. The steam microwave oven is in standby.

Operation Instructions

■ Microwave Mode



Baking Tray

Cavity Bottom

Suggested Accessory:

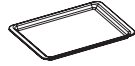

Accessories Location:





Microwaves can heat food quickly and are suitable for reheating food.

	Microwave Power	Time
Default Setting	900W	30 sec
Setting Range	100W - 900W	10 sec - 59 mins and 55 sec

 **Attention!** Do not use metal utensils (except our suggested accessory) to cook under this cooking function, otherwise sparks may be generated and cause malfunction.

Example: Set the cooking time to 2 minutes; microwave power is 900W.

Steps:

1. In standby mode, press  button on control panel or turn the knob to  microwave mode then press the knob to enter microwave function setting. Microwave Power will flash, turn the knob until display shows 900. Press the knob to confirm (as shown in the diagram below). The display will jump to minute setting automatically.



2. Turn the knob until the minute display shows 02. Press the knob to confirm (as shown in the diagram below). The display will jump to second setting automatically.



3. Press the knob to confirm 00 setting in second (as shown in the diagram below).



4. Setting is completed, microwave steam oven will start cooking.

Operation Instructions

■ Steam Mode



Steam Tray



Middle Layer

Suggested Accessory:

Accessories Location:



Steam cooking preserves the original taste, nutrients and color of food. It is suitable for steaming vegetables, meat and seafood or braising soup. Always ensure the water tank is filled before using this mode.

	Temperature	Time
Default Setting	100°C	20 mins
Setting Range	50°C - 110°C	5 mins - 6 hours and 59 mins

Example: Set the cooking time to 1 hour and 40 minutes; cooking temperature is 110°C.

Steps:

1. In standby mode, turn the knob clockwise to  Steam Mode. The icon will flash. Press the knob to confirm (as shown in the diagram below). The display will jump to hour setting automatically.



2. Turn the knob until the hour display shows 01. Press the knob to confirm (as shown in the diagram below). The display will jump to minute setting automatically.

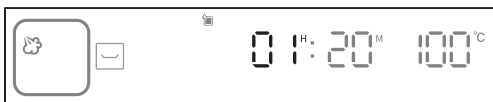

3. Turn the knob until the minute display shows 40. Press the knob to confirm (as shown in the diagram below). The display will jump to temperature setting automatically.



4. Turn the knob until the temperature display shows 90°C. Press the knob to confirm (as shown in the diagram below).



5. Setting is complete. The steam microwave oven will start cooking.

Operation Instructions

■ Steam + Microwave Mode



Grill Rack



Middle Layer

Suggested Accessory:

Accessories Location:



Steam cooking preserves the original taste, nutrients and color of food. It is suitable for steaming vegetables, meat and seafood or braising soup. Always ensure the water tank is filled before using this mode.

	Temperature	Time
Default Setting	100°C	15 mins
Setting Range	50°C - 110°C	5 mins - 6 hours and 59 mins

 Attention! Do not use metal utensils (except our suggested accessory) to cook under this cooking function, otherwise sparks may be generated and cause malfunction.

Example: Set the cooking time to 1 hour and 40 minutes; cooking temperature is 90°C.

Steps:

1. In standby mode, turn the knob clockwise to  Steam + Microwave Mode. The icon will flash. Press the knob to confirm (as shown in the diagram below). The display will jump to hour setting automatically.



2. Turn the knob until the hour display shows 01. Press the knob to confirm (as shown in the diagram below). The display will jump to minute setting automatically.



3. Turn the knob until the minute display shows 40. Press the knob to confirm (as shown in the diagram below). The display will jump to temperature setting automatically.



4. Turn the knob until the temperature display shows 90°C. Press the knob to confirm (as shown in the diagram below).



5. Setting is complete. The steam microwave oven will start cooking.

Operation Instructions

■ Upper Grill Mode

Grill Rack

Middle Layer

Suggested Accessory:



Accessories Location:



Suitable for roasting baking - food or at a final stage of roasting or baking. It helps browning the surface of your dish.

	Temperature	Time
Default Setting	110°C	25 mins
Setting Range	50°C - 230°C	5 mins - 3 hours and 59 mins

Example: Set the cooking time to 40 minutes; temperature is 210°C.

Steps:

1. In standby mode, turn the knob clockwise to  Upper Grill mode. The icon will flash. Press the knob to confirm (as shown in the diagram below). The display will jump to hour setting automatically.



2. Press the knob to confirm 00 hour setting (as shown in the diagram below). The display will jump to minute setting automatically.



3. Turn the knob until the minute display shows 40. Press the knob to confirm(as shown in the diagram below). The display will jump to temperature setting automatically.



4. Turn the knob until temperature display shows 210°C. Press knob to confirm the upper grill temperature (as shown in the diagram below).



5. Setting is complete. The microwave steam oven will start cooking.

Operation Instructions

■ Upper Grill + Microwave Mode

Grill Rack

Middle Layer

Suggested Accessory:



Accessories Location:



Suitable for roasting baking food, cooking time can be shorten with microwave.

	Temperature	Time
Default Setting	100°C	20 mins
Setting Range	50°C - 230°C	5 mins - 3 hours and 59 mins

 Attention! Do not use metal utensils (except our suggested accessory) to cook under this cooking function, otherwise sparks may be generated and cause malfunction.

Example: Set the cooking time to 40 minutes; temperature is 210°C.

Steps:

1. In standby mode, turn the knob clockwise to  Upper Grill + Microwave mode. The icon will flash. Press the knob to confirm (as shown in the diagram below). The display will jump to hour setting automatically.



2. Press the knob to confirm 00 hour setting (as shown in the diagram below). The display will jump to minute setting automatically.

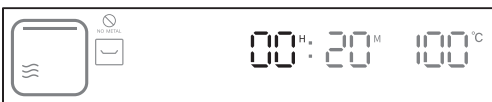

3. Turn the knob until the minute display shows 40. Press the knob to confirm(as shown in the diagram below). The display will jump to temperature setting automatically.



4. Turn the knob until temperature display shows 210°C. Press knob to confirm the upper grill temperature (as shown in the diagram below).



5. Setting is complete. The microwave steam oven will start cooking.

Operation Instructions

■ Bottom Grill Mode

Grill Rack

Bottom Layer

Suggested Accessory:



Accessories Location:



Suitable for baking the final stage or for food that needs to be cooked from the bottom periodically during cooking, e.g. pizzas, macaroon.

	Temperature	Time
Default Setting	100°C	20 mins
Setting Range	50°C - 230°C	5 mins - 3 hours and 59 mins

Example: Set the cooking time to 40 minutes; temperature is 210°C.

Steps:

1. In standby mode, turn the knob clockwise to  Bottom Grill mode. The icon will flash. Press the knob to confirm (as shown in the diagram below). The display will jump to hour setting automatically.



2. Press the knob to confirm 00 hour setting (as shown in the diagram below). The display will jump to minute setting automatically.

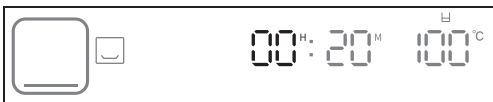

3. Turn the knob until the minute display shows 40. Press the knob to confirm(as shown in the diagram below). The display will jump to temperature setting automatically.



4. Turn the knob until temperature display shows 210°C. Press knob to confirm the bottom grill temperature (as shown in the diagram below).



5. Setting is complete. The microwave steam oven will start cooking.

Operation Instructions

■ Conventional Bake Mode

Grill Rack

Bottom Layer

Suggested Accessory:



Accessories Location:



	Temperature	Time
Default Setting	180°C	30 mins
Setting Range	50°C - 230°C	5 mins - 3 hours and 59 mins

Example: Set the cooking time to 40 minutes; upper grill temperature is 210°C, bottom grill temperature is 180°C.

Steps:

1. In standby mode, turn the knob clockwise to  Conventional Bake mode. The icon will flash. Press the knob to confirm (as shown in the diagram below). The display will jump to hour setting automatically.



2. Press the knob to confirm 00 hour setting (as shown in the diagram below). The display will jump to minute setting automatically.

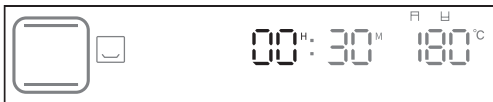

3. Turn the knob until the minute display shows 40. Press the knob to confirm(as shown in the diagram below). The display will jump to upper grill temperature setting automatically.



4. Turn the knob until temperature display shows 210°C. Press knob to confirm the bottom upper grill temperature (as shown in the diagram below). The display will jump to bottom grill temperature setting automatically.



5. Turn the knob until temperature display shows 180°C. Press knob to confirm the bottom grill temperature (as shown in the diagram below).



6. Setting is complete. The microwave steam oven will start cooking.

Operation Instructions

■ Conventional Bake + Microwave Mode

Grill Rack

Bottom Layer

Suggested Accessory:



Accessories Location:



Traditional single-level baking and grilling mode. Heat is released from the top and bottom to get food baked evenly and quickly with microwave. Suitable for cooking meat, bread, pastries and desserts etc.

	Temperature	Time
Default Setting	180°C	25 mins
Setting Range	50°C - 230°C	5 mins - 3 hours and 59 mins



Attention! Do not use metal utensils (except our suggested accessory) to cook under this cooking function, otherwise sparks may be generated and cause malfunction.

Example: Set the cooking time to 40 minutes; upper grill temperature is 180°C, bottom grill temperature is 160°C.

Steps:

1. In standby mode, turn the knob clockwise to  Conventional Bake + Microwave mode. The icon will flash. Press the knob to confirm (as shown in the diagram below). The display will jump to hour setting automatically.



2. Press the knob to confirm 00 hour setting (as shown in the diagram below). The display will jump to minute setting automatically.



3. Turn the knob until the minute display shows 40. Press the knob to confirm (as shown in the diagram below). The display will jump to upper grill temperature setting automatically.



4. Turn the knob until temperature display shows 160°C. Press knob to confirm the bottom grill temperature (as shown in the diagram below).



5. Setting is complete. The microwave steam oven will start cooking.

Operation Instructions

■ Convection Mode

Baking Tray

Bottom layer

Suggested Accessory:



Accessories Location:



The upper and lower heaters and rear fan operate simultaneously in this mode. Suitable for all baking dishes, such as meat, seafood, pizzas, bread and cookies, pastries and desserts. It is recommended to place aluminium foil or baking paper onto the baking tray before cooking.

	Temperature	Time
Default Setting	160°C	20 mins
Setting Range	80°C - 230°C	5 mins - 3 hours and 59 mins

Example: Set the cooking time to 40 minutes; cooking temperature is 210°C.

Steps:

1. In standby mode, turn the knob clockwise to  Convection Mode. The icon will flash. Press the knob to confirm (as shown in the diagram below). The display will jump to hour setting automatically.



2. Press the knob to confirm the 00 hour setting (as shown in the diagram below). The display will jump to minute setting automatically.



3. Turn the knob until the minute display shows 40. Press the knob to confirm (as shown in the diagram below). The display will jump to temperature setting automatically.



4. Turn the knob until the temperature display shows 210°C. Press the knob to confirm (as shown in the diagram below).





5. Setting is complete. The combi steamer will start cooking.



Operation Instructions

■ Turbo Convection Mode

Suggested Accessory: 

Accessories Location: 

Cooking time is shortened in this mode to bake and roast food quickly. It is suitable for baking large meat and cakes. It is recommended to place aluminum foil or baking paper onto the baking tray before cooking.

	Temperature	Time
Default Setting	180°C	25 mins
Setting Range	50°C - 230°C	5 mins - 3 hours and 59 mins

Example: Set the cooking time to 40 minutes; cooking temperature is 210°C.

Steps:

1. In standby mode, turn the knob clockwise to  Turbo Convection Mode. The icon will flash. Press the knob to confirm (as shown in the diagram below). The display will jump to hour setting automatically.



2. Press the knob to confirm the 00 hour setting. (as shown in the diagram below). The display will jump to minute setting automatically.



3. Turn the knob until the minute display shows 40. Press the knob to confirm (as shown in the diagram below). The display will jump to temperature setting automatically.



4. Turn the knob until the temperature display shows 210°C. Press the knob to confirm (as shown in the diagram below).



5. Setting is complete. The combi steamer will start cooking.

Operation Instructions

■ Turbo Convection + Microwave Mode



Baking Tray

Bottom layer

Suggested Accessory:

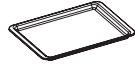

Accessories Location:



Traditional single-level baking and grilling mode. Heat is released from the top and bottom to get food baked evenly and quickly with microwave. Suitable for cooking meat, bread, pastries and desserts etc.

	Temperature	Time
Default Setting	180°C	15 mins
Setting Range	50°C - 230°C	5 mins - 3 hours and 59 mins



NO METAL

Attention! Do not use metal utensils (except our suggested accessory) to cook under this cooking function, otherwise sparks may be generated and cause malfunction.

Example: Set the cooking time to 40 minutes; cooking temperature is 210°C.

Steps:

1. In standby mode, turn the knob clockwise to  Turbo Convection + Microwave Mode. The icon will flash. Press the knob to confirm (as shown in the diagram below). The display will jump to hour setting automatically.



2. Press the knob to confirm the 00 hour setting. (as shown in the diagram below). The display will jump to minute setting automatically.

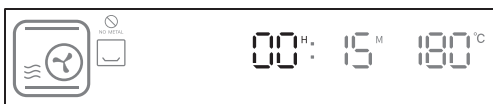

3. Turn the knob until the minute display shows 40. Press the knob to confirm (as shown in the diagram below). The display will jump to temperature setting automatically.



4. Turn the knob until the temperature display shows 210°C. Press the knob to confirm (as shown in the diagram below).



5. Setting is complete. The steam microwave oven will start cooking.

Operation Instructions

■ Convection + Steam Mode



Baking Tray

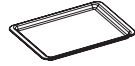

Bottom layer



Suggested Accessory:

Accessories Location:

This mode combines upper, lower heat, hot air and steam cooking. It is a perfect all-in-one combination cooking. Adding steam during the cooking process can prevent moisture loss during high temperature cooking. Suitable for cooking all types of food, such as large cuts of meat or baking moist cakes.

	Temperature	Time
Default Setting	180°C	20 mins
Setting Range	80°C - 230°C	5 mins - 3 hours and 59 mins

Example: Set the cooking time to 40 minutes; cooking temperature is 210°C.

Steps:

1. In standby mode, turn the knob clockwise to  Convection + Steam Mode. The icon will flash. Press the knob to confirm (as shown in the diagram below). The display will jump to hour setting automatically.



2. Press the knob to confirm the 00 hour setting (as shown in the diagram below). The display will jump to minute setting automatically.



3. Turn the knob until the minute display shows 40. Press the knob to confirm (as shown in the diagram below). The display will jump to temperature setting automatically.



4. Turn the knob until the temperature display shows 210°C. Press the knob to confirm (as shown in the diagram below).



5. Setting is complete. The combi steamer will start cooking.

Operation Instructions

■ Convection + Steam + Microwave Mode

Suggested Accessory:  Baking Tray
 Accessories Location:  Bottom layer

This mode combines upper, lower heat, hot air, steam and microwave cooking. It is a perfect all-in-one combination cooking. Adding steam during the cooking process can prevent moisture loss during high temperature cooking, while microwave can shorten the total cooking time. Especially suitable for cooking large portion of food, such as large cuts of meat.

	Temperature	Time
Default Setting	180°C	15 mins
Setting Range	80°C - 230°C	5 mins - 3 hours and 59 mins

 **Attention!** Do not use metal utensils (except our suggested accessory) to cook under this cooking function, otherwise sparks may be generated and cause malfunction.

Example: Set the cooking time to 40 minutes; cooking temperature is 210°C.

Steps:

- In standby mode, turn the knob clockwise to  Convection + Steam + Microwave mode. The icon will flash. Press the knob to confirm (as shown in the diagram below). The display will jump to hour setting automatically.



- Press the knob to confirm 00 hour setting (as shown in the diagram below). The display will jump to minute setting automatically.



- Turn the knob until the minute display shows 40. Press the knob to confirm (as shown in the diagram below). The display will jump to temperature setting automatically.



- Turn the knob until temperature display shows 210°C. Press knob to confirm the bottom grill temperature (as shown in the diagram below).



- Setting is complete. The microwave steam oven will start cooking.

Operation Instructions

■ Keep Warm Mode

Baking Tray

Middle layer

Suggested Accessory:

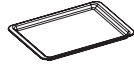

Accessories Location:



Keeping food warm with hot air. Suitable for keeping cooked dishes warm.

	Temperature	Time
Default Setting	55°C	20 mins
Setting Range	50°C - 110°C	5 mins - 6 hours and 59 mins

Example: Set the cooking time to 1 hours and 30 minutes; cooking temperature is 60°C.

Steps:

1. In standby mode, turn the knob clockwise to  Keep Warm Mode. The icon will flash. Press the knob to confirm (as shown in the diagram below). The display will jump to hour setting automatically.



2. Turn the knob until the hour display shows 01. Press the knob to confirm (as shown in the diagram below). The display will jump to minute setting automatically.

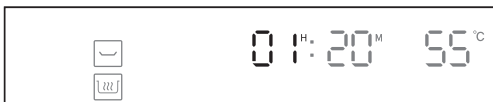

3. Press the knob to confirm the "30" minute setting (as shown in the diagram below). The display will jump to temperature setting automatically.



4. Turn the knob until the temperature display shows 60°C. Press the knob to confirm (as shown in the diagram below).



5. Setting is complete. The steam microwave oven will start cooking.

Operation Instructions

■ Drying Fruit Mode



Baking Tray

Middle Layer

Suggested Accessory:

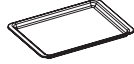

Accessories Location:



Food is dehydrated with hot air in low heat. Suitable for preparing dried fruit and vegetable slices or meat jerkies.

	Temperature	Time
Default Setting	60°C	20 mins
Setting Range	40°C - 90°C	5 mins - 12 hours and 59 mins

Example: Set the cooking time to 2 hours; cooking temperature is 60°C.

Steps:

1. In standby mode, turn the knob clockwise to  Drying Fruit Mode. The icon will flash. Press the knob to confirm (as shown in the diagram below). The display will jump to hour setting automatically.



2. Turn the knob until the hour display shows 02. Press the knob to confirm (as shown in the diagram below). The display will jump to minute setting automatically.

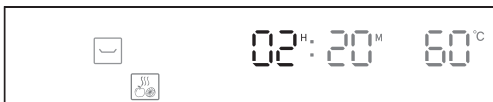

3. Press the knob to confirm the 00 minute setting (as shown in the diagram below). The display will jump to temperature setting automatically.



4. Turn the knob until the temperature display shows 90°C. Press the knob to confirm (as shown in the diagram below).



5. Setting is complete. The steam microwave oven will start.

Operation Instructions

■ Slow Cook Mode



Baking Tray

Middle layer

Suggested Accessory:

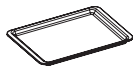

Accessories Location:



Steam is injected to maintain temperature inside the oven for slow cooking. Low temperature is used, meat and seafood can be preserved the original flavor without overcooking. Food can be placed in vacuum bags. Always ensure that the water tank is filled before using this mode.

	Temperature	Time
Default Setting	60°C	60 mins
Setting Range	50°C - 90°C	60 mins - 12 hours and 59 mins

Example: Set the cooking time to 1 hour 40 minutes; cooking temperature is 60°C.

Steps:

1. In standby mode, turn the knob clockwise to Slow Cook Mode. The icon will flash. Press the knob to confirm (as shown in the diagram below). The display will jump to hour setting automatically.



2. Press knob to confirm hour 01 (as shown in the diagram below). The display will jump to minute setting automatically.



3. Turn the knob until the minute display shows 40. Press the knob to confirm (as shown in the diagram below). The display will jump to temperature setting automatically.



4. Press the knob to confirm 60°C temperature setting. (as shown in the diagram below).



5. Setting is complete. The steam microwave ovenr will start cooking.

Operation Instructions

■ Proving Mode

Steam Tray

Bottom layer

Suggested Accessory:



Accessories Location:



This mode works with steam to ensure stable high temperature and humidity inside the oven. It allows dough (for pizza or bread) to rise quicker in a stable environment, and is used for fermenting dough for pizzas or bread. Always ensure that the water tank is filled before using this mode.

	Temperature	Time
Default Setting	35°C	40 mins
Setting Range	25°C - 50°C	5 mins - 12 hours and 59 mins

Example: Set the cooking time to 40 minutes; cooking temperature is 35°C.

Steps:

1. In standby mode, turn the knob clockwise to  Proving Mode. The icon will flash. Press the knob to confirm (as shown in the diagram below). The display will jump to hour setting automatically.



2. Press the knob to confirm the 00 hour setting (as shown in the diagram below). The display will jump to minute setting automatically.



3. Turn the knob until the minute display shows 40. Press the knob to confirm (as shown in the diagram below). The display will jump to temperature setting automatically.



4. Turn the knob to confirm the 35°C temperature setting (as shown in the diagram below).



5. Setting is complete. The steam microwave oven will start cooking.

Operation Instructions

■ Bread Reheat Mode



Baking Tray

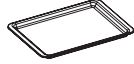

Middle Layer

Suggested Accessory:

Accessories Location:



Bread is reheated at a regulated temperature and steam is added to reheat bread that tastes just like freshly-baked. Two heating modes are available: Room temperature bread and refrigerated bread. Always ensure that the water tank is filled before using this mode.

Suggested cooking time: Reheating time for frozen bread: about 10-15 minutes; Reheating time for room temperature bread: about 8-13 minutes. It is recommended to add 5-10 minutes for bread with fillings. This suggested cooking time is solely for reference. Cooking time is affected by the bread's quantity, size, type and personal taste.

	Temperature	Time
Default Setting	180°C	10 mins
Setting Range	fixed	5 mins - 59 mins

Example: Cooking bread that has been refrigerated. Set the cooking time to 25 minutes

Steps:

1. In standby mode, turn the knob clockwise to  Bread Reheat Mode. The icon will flash. Press the knob to confirm (as shown in the diagram below). The display will jump to minute setting automatically.



2. Turn the knob until the minute display shows 25. Press the knob to confirm (as shown in the diagram below).



3. Setting is complete.

Operation Instructions

■ Defrost Mode



Baking Tray

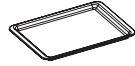

Middle layer

Accessories Location:



Suggested Accessory:

Defrost chilled or frozen food with Microwave.

	Food Weight	Time
Default Setting	500g	7 mins 40 sec
Setting Range	100g - 2000g	Automatically adjusted based on entered food weight



NO METAL

Attention! Do not use metal utensils (except our suggested accessory) to cook under this cooking function, otherwise sparks may be generated and cause malfunction.

Example: Defrost 600g food

Steps:

1. In standby mode, turn the knob anti-clockwise to Defrost mode. The icon will flash. Press the knob to confirm (as shown in the diagram below). The display will jump to hour setting automatically.



2. Turn the knob until the weight value display shows 600. Press the knob to confirm (as shown in the diagram below).



3. Setting is complete. The microwave steam oven will start cooking.

Operation Instructions

■ Preheat Mode

The Preheat Mode can be operated with steam or baking mode. The oven will be heated to preset temperature.

	Steam Preheating	Baking Preheating
	Temperature	Temperature
Default Setting	100°C	180°C
Setting Range	50°C - 110°C	100°C - 230°C

Oven will automatically adjust the cooking time according to set temperature. "END" will be displayed and an audio tone will be heard when the temperature reaches the preset temperature. Current time is displayed during preheating. Always ensure that the water tank is filled before using steam preheating.

Example: Set the steam preheating temperature to 80°C.

Steps:

1. In standby mode, turn the knob clockwise to  Preheat Mode. The icon will flash. Steam is the default setting. Press the knob to confirm (as shown in the diagram below).



2. The display will jump to temperature setting automatically. Turn the knob until temperature display shows 100°C. Press knob to confirm the bottom grill temperature (as shown in the diagram below).



3. Setting is complete. The steam microwave oven will start preheating.

Operation Instructions

Example: Set the baking preheating temperature to 200°C.

Steps:

1. In standby mode, turn the knob clockwise to Preheating Mode. The icon will flash. Steam is the default setting. Turn the knob to select the baking preheating mode, and then press the knob to confirm (as shown in the diagram below).



2. The display will jump to temperature setting automatically. Turn the knob until the display shows 200°C. Press the knob to confirm (as shown in the diagram below).



3. Setting is complete. The steam microwave oven will start preheating.

When preheating is complete, the display will show “END” and an audio tone will be heard. After preheating the combi steamer, you can select other cooking modes to continue your cooking as required.

Important: The function of “Adjust or Increase the Cooking Time during/after Cooking is Completed” is not available in this mode.

Operation Instructions

■ Air frying Mode



Air Fry Basket

Middle Layer

Suggested Accessory:



Accessories Location:



A fan is used to circulate heat in the oven cavity to create convection, allowing the food to be baked in a shorter time to create a crispy effect. It is suitable for food that needs to be air-fried or for baking larger meats and pastries.

	Temperature	Time
Default Setting	180°C	25 mins
Setting Range	80°C - 230°C	5 mins - 3 hours and 59 mins

Example: Set the cooking time to 30 minutes; temperature is 210°C

Steps:

1. In standby mode, turn the knob anti-clockwise to  Air Fry mode. The icon will flash. Press the knob to confirm (as shown in the diagram below). The display will jump to hour setting automatically.



2. Press the knob to confirm 00 hour setting (as shown in the diagram below). The display will jump to minute setting automatically.



3. Turn the knob until the minute display shows 30. Press the knob to confirm (as shown in the diagram below). The display will jump to temperature setting automatically.



4. Turn the knob until temperature display shows 210°C. Press knob to confirm the temperature (as shown in the diagram below).



5. Setting is complete. The microwave steam oven will start cooking.

Operation Instructions

■ Cavity Drying Mode

In this mode, the oven is heated to a high temperature so any excessive moisture and steam are evaporated. This function is used for drying the oven after any steam cooking modes.

	Temperature	Time
Default Setting	180°C	15 mins
Setting Range	Cannot be adjusted	Cannot be adjusted

Steps:

1. In standby mode, turn the knob anti-clockwise to  Cavity Drying Mode. The icon will flash. (as shown in the diagram below).



2. Press the knob to confirm. The steam microwave oven will start cooking (as shown in the diagram below).





Operation Instructions

■ Descaling Mode



Water used in steaming mode may result in scale accumulated inside cavity and water pipe.

“Descaling” icon  will be on once combi steamer has reached 100hrs steam related cooking time to remind the user to run the descaling programme mode. The light will stay on until the descaling is performed.

Descaling is carried out in three stages that involve one descaling process and two descaling and cleaning processes. The user has to change the liquid in the tank 3 times during the entire cleaning process. It is also necessary to empty the drip tray by cleaning up. Icon  will be lighted to remind cleaning up the drip tray is needed.

Also, descaler is required for this mode. Customer can select the Wpro descaler under Whirlpool brand. This product can be used in steamer for cleaning limescale deposits effectively, optimizing machine performance and prolonging the lifespan of the appliance. For more details, please visit our website: www.whirlpool.com.hk

For satisfactory results, follow the suggested dosage for descaler and water below:

Stage 1: Descaling. Running time is 56 minutes. Suggested dosage: 30ml descaling agent and 300ml pure water.

Stage 2: Descaling and cleaning process. Running time is 4 minutes. Suggested dosage: 300ml pure water.

	Temperature	Time
Default Setting	Cannot be adjusted	60 mins
Setting Range	Cannot be adjusted	Cannot be adjusted

Steps:

1. Stage 1: Descaling

A. Add 30ml descaler and 300ml water into water tank.

B. In standby mode, turn the knob anti-clockwise to  Descaling Mode. The icon will flash. Press the knob to confirm (as shown in the diagram below).



C. The descaling mode will start (as shown in the diagram below).



D. Stage 1 takes 56 minutes. When done, the time display digits will flash and an audio tone will sound to indicate stage 1 is complete.  Drip tray cleaning reminder icon will light up on the display panel to remind the user to empty the drip tray.



E. Pour out the dirty liquid and put the drip tray back into place.

Operation Instructions

2. Stage 2: Descaling and cleaning process

- A. Open the oven door, add 300ml clean water into water tank.
- B. Put the water tank back into place and close the oven door. Press knob to confirm and resume descaling and cleaning process.



- C. When done, the time display digits will flash and an audio tone will sound to indicate descaling is complete.  Drip tray cleaning reminder icon will light up on the display panel to remind the user to empty the drip tray.



- D. Pour out the dirty liquid and put the drip tray back into place.

3. Descaling process is completed

Important:

1. The function of “Combination Button: Cavity temperature display” is not available in this mode.
2. The function of “Adjust or Increase the Cooking Time during/after Cooking is Completed” is not available in this mode.
3. Descaling mode will be interrupted if the steps of descaling mode is taken in the wrong way (including pause during the descaling process or open and close the oven door not following instructions etc). Please restart descaling mode and follow the instructions in the manual.

Operation Instructions

■ DIY Cooking Mode

It is used to complete a variety of different cooking function combination at one time automatically, make cooking more diverse and convenient.

For example, first cook with Steam Mode at 110°C for 1 hour 20 minutes, then cook with Turbo Convection + Microwave mode at 190°C for 1 hour 30 minutes, and then cook for 1 hour 30 minutes at 190°C with Turbo Convection mode.

Steps:

1. In standby mode, turn knob to  DIY Cooking mode. The icon will flash. Press to confirm the function. (As shown in the diagram below). The display will jump to cooking mode setting automatically.



2. Turn knob to  Steam mode. The icon will flash. Press knob to confirm cooking mode (as shown in the diagram below). The display will jump to hour setting automatically.

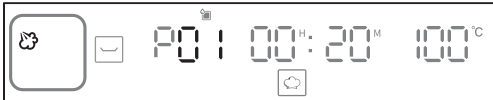

3. Turn knob until the hour display shows 01. Press knob to confirm (as shown in the diagram below). The display will jump to minute setting automatically.

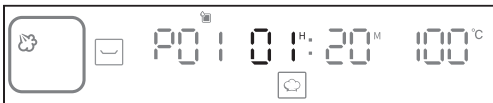

4. Turn knob until the minute display shows 20. Press knob to confirm (as shown in the diagram below). The display will jump to temperature setting automatically.



5. Turn knob until the temperature display shows 110°C. Press  to confirm the 1st cooking function setting and jump to next cooking function setup. (as shown in the diagram below).



6. Turn knob to  Turbo Convection + Microwave mode. The icon will flash. Press knob to confirm cooking mode (as shown in the diagram below). The display will jump to hour setting automatically.



Operation Instructions

7. Turn knob until the hour display shows 01. Press knob to confirm (as shown in the diagram below). The display will jump to minute setting automatically.



8. Turn knob until the minute display shows 30. Press knob to confirm (as shown in the diagram below). The display will jump to temperature setting automatically.



9. Turn knob until the temperature display shows 190°C. Press  to confirm the 2nd cooking function setting and jump to next cooking function setup. (as shown in the diagram below).



10. Turn knob to  Turbo Convection mode. The icon will flash. Press knob to confirm cooking mode (as shown in the diagram below). The display will jump to hour setting automatically.



11. Turn knob until the hour display shows 01. Press knob to confirm (as shown in the diagram below). The display will jump to minute setting automatically.



12. Turn knob until the minute display shows 30. Press knob to confirm (as shown in the diagram below). The display will jump to temperature setting automatically.



13. Turn knob until the temperature display shows 190°C. Press  to confirm the 3rd cooking function setting



14. Setting is completed. The microwave steam oven will start cooking.

Operation Instructions

■ Adjust or Increase the Cooking Time during/after Cooking is Completed



A. Adjust the cooking time during cooking process

You can extend or shorten the cooking time and the temperature as required during the cooking process.
Example: Change the cooking time and temperature settings from 01:40 and 90°C to 02:00 and 100°C.

Steps:

1. During cooking, press the knob to interrupt and pause the cooking. The time display will flash (as shown in the diagram below).



2. Press the setting button . The display will go to the reset cooking time screen automatically. The hour digit flashes, and the  "Extended Cooking Time" icon lights up on the display (as shown in the diagram below).



3. Turn the knob until the hour display shows 02. Press the setting button  to confirm (as shown in the diagram below). The display will jump to minute setting automatically.

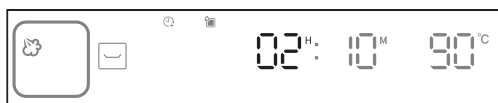

4. Turn the knob until the minute display shows 00. Press the setting button  to confirm (as shown in the diagram below). The display will jump to temperature setting automatically.



5. Turn the knob until the temperature display shows 100°C. Press the knob to confirm (as shown in the diagram below).



6. Setting is complete. Cooking will be resumed with new settings.

Operation Instructions

B. Increase the cooking time after cooking is completed

You can increase the cooking time after cooking is completed. Temperature cannot be adjusted.

	Temperature	Time
Setting Range	Cannot be adjusted	1 min to 59 mins

When cooking is completed, the “END” Will be shown on display and an audio tone sounds. The  “Extended Cooking Time” icon will light up on the display (As shown in the diagram below).



To increase the cooking time, follow the steps below:

Example: Cooking is completed and need to increase the cooking time by 3 minutes.

Steps:

1. Press the knob to confirm to increase the cooking time, the display will jump to minute setting automatically.



2. Turn the knob until the minute display shows 03. Press the knob to confirm (as shown in the diagram below).



3. Setting is complete. Cooking will resume with added cooking time under previous settings (as shown in the diagram below).



Note: If no action is taken within 5 minutes after cooking is completed, the combi steamer will return to standby mode.

Operation Instructions

■ Preset Function

You must set the clock before using the preset function. For instructions on clock setting, please see “Setting the Clock” on page 73 of this instruction manual.

Example: The current time is 12:00. You want to preset cooking time for the Bottom Grill Mode. Cooking time is 1 hour and 30 minutes and temperature is 90°C. Cooking will stop at 14:00.

Steps:

1. In standby mode, turn the knob clockwise  Bottom Grill Mode. The icon will flash. Press the knob to confirm (as shown in the diagram below). The display will jump to hour setting automatically.



2. Press the knob to confirm the 01 hour setting (as shown in the diagram below). The display will jump to minute setting automatically.



3. Turn the knob until the minute display shows 30. Press the knob to confirm (as shown in the diagram below). The display will jump to temperature setting automatically.



4. Turn the knob until the temperature display shows 90°C. Press the setting button for 3 seconds  to confirm (as shown in the diagram below).



5. Turn the knob until the hour display shows 14. Press the knob to confirm (as shown in the diagram below). The display will jump to minute setting automatically.



6. Turn the knob until the minute display shows 40. Press the knob to confirm. (as shown in the diagram below).





7. The  preset function icon of the display panel will flash. Display will change from operating time back to the current time 16:30, indicating preset setting is complete (as shown in the diagram below).



Operation Instructions

A. Checking Preset Function Status

Press and hold the setting button  for 3 seconds to check the preset stop time. The preset function icon will flash. Press and hold the setting button  for 3 seconds again to return to the preset function screen.

B. Cancelling Preset Function:

To cancel any preset function setting, press the  power button directly. The combi steamer will return to the standby screen automatically.

Important: Preset Function is available in 12 Mainly Cooking Modes, Bread Reheat Mode, Slow Cook Mode and Drying Fruit Mode. (See “Control Panel – Major Features/ Description of Major Features on P.65-69 for details) Suggestion: Preset cooking operation may be cancelled if children touch the screen accidentally. To avoid this, activate the child lock function after setting the preset function. For instructions on setting the child lock, please see “Control Panel – Basic Functions” on page 65 of this instruction manual. The child lock will not affect cooking. The steam microwave oven will start cooking normally at the preset time.

Operation Instructions

■ Auto Menu

In Standby mode, press  setting button to enter into Auto Menu to select recipe (P01 to P21), press knob to confirm the recipe.



Recipe no.	Dish	Recipe	Accessory location
P01	Steam Seabass	500g sea bass, 6 slices ginger, 6 green onions, 20ml soy sauce, 50ml oil 1. After cleaning the seabass, marinate it with oil and black pepper for half an hour; 2. Place ginger and green onion at the bottom of the dish, and put the seabass onto the dish; 3. Place in the middle layer of the microwave steam oven and select P01; 4. After taking it out of the oven, pour out the sauce on the plate, add in soy sauce and hot oil.	middle layer
P02	Baby Cabbage with Garlic	400g baby cabbage, garlic, 30ml soy sauce, 1 teaspoon salt, 70g oil, 10g oyster sauce 1. Cut the baby cabbage in half then cut each into 6 small pieces, and lay them flat on a plate; 2. Chop the garlic into minced garlic, add seasonings, pour hot oil to make garlic sauce; 3. Pour the sauce over the baby cabbage; 4. Place in middle layer of the of the microwave steam oven and select P02.	middle layer
P03	White clam steamed egg	2 eggs, 200ml room temperature water, 16 pieces white clam, ginger slices, rice wine, salt, soy sauce, Appropriate amount of oil. 1. Soak the white clams in salt water, add appropriate amount of oil, and soak for 1 hour; 2. Heat hot water in a pot, add ginger slices and rice wine, pour in the white clams, when shells slightly open take them all out from the water; 3. Add an appropriate amount of salt to the eggs and stir evenly, then pour in room temperature water and stir again evenly; 4. Place the white clams in the bottom of a shallow dish, with the opening facing up, and pour in the egg liquid; 5. Put in the middle layer of microwave steam oven and select P03; 6. Take it out of the oven and sprinkle with chopped spring onion, pour soy sauce and hot oil.	middle layer
P04	Steam Rice	50g rice, 370ml water 1. Wash the rice, pour it into a baking pan, and pour in water; 2. Place in the middle layer of the microwave steam oven and select P04;	middle layer
P05	Crispy Pork	700g pork belly, 2 tbsp salt, 2 tbsp five-spice powder, 1 tbsp white vinegar, 1 tbsp baking soda 1. Use a fire lance to burn the pork hair on the pork belly skin, and scrape with a knife to clean it; 2. Make a deep groove on the meat surface and sprinkle with five-spice powder and salt on all sides, except the pork skin, evenly. 3. Place the pork in a pot with cold water, cook until foam forms, take out the pork and clean with cold water; 4. Clean the pig skin, use a small sharp knife to poke holes, and penetrate the skin layer densely; 5. Pour an appropriate amount of white vinegar into the bottom of the plate and soak the pork skin side down for 5 minutes; 6. Pork skin side up, wrap the other sides with tin foil, and put it in the refrigerator overnight until the surface of the pig skin is dry; 7. Place in the middle layer of microwave steam oven and select P05.	middle layer

Others

Recipe no.	Dish	Recipe	Accessory location
P06	Honey Chicken Wings	<p>12 pieces chicken wing, 70g marinated chicken wing powder, 20g minced garlic, 30g corn starch, appropriate amount of honey, appropriate amount of oil</p> <ol style="list-style-type: none"> 1. Wash the chicken wings, soak in water for 20 minutes, and drain; 2. Pour in the corn starch, then the seasonings, mix well, and marinate for 1 hour; 3. Lay the chicken wings on a baking tray, place them in the middle layer of the microwave steam oven, and select P06. 	middle layer
P07	Roasted Rack of Lamb	<p>5 pieces of lamb chops, 1 onion, 3 green onions, 6 slices of ginger, 1 teaspoon of salt, 2 tbsp of light soy sauce, 1 tsp rice wine, 1 tsp honey, 4 tsp cumin powder, 2 tsp garlic powder, white pepper 1 tsp, red chili powder 1 tsp</p> <ol style="list-style-type: none"> 1. Marinate the lamb chops with onions, ginger, salt, light soy sauce, rice wine, and honey for 2 hours; 2. Mix the powdery seasonings evenly to make a marinade; 3. Cut the onions into sections and place them on the bottom, then put the lamb chops on top; 4. Evenly coat both sides of the lamb chops with marinade; 5. Place in the middle layer of the microwave steam oven and select P07; 6. For the remaining 10 minutes, turn the lamb chops over and continue grilling. 	middle layer
P08	Hamburger Steak	<p>200g minced beef, 150g minced pork, half onion (chopped), 1 egg</p> <ol style="list-style-type: none"> 1. Mix all burger ingredients and marinade evenly and press into a patty shape. 2. Place the burger steak on the baking tray, place it in the middle layer of microwave steam oven, and select P08. 	middle layer
P09	BBQ Pork	<p>400-500g Pork scotch fillet</p> <p>Seasonings: 1 tbsp salt, 4 tbsp sugar, 1/4 tsp chicken powder, 1 egg, 2 dried onions, 2 cloves of garlic, 1 stalk of coriander, 1 tablespoon of preserved beans (chopped), 1/2 tsp of rose wine, 4 tbsp of maltose, a small amount of ginger paste.</p> <ol style="list-style-type: none"> 1. Prepare marinade seasoning. First saute the dried onions, minced garlic, coriander and preserved beans until fragrant. Then add sugar, salt, natural chicken powder and eggs. Mix well and ferment at room temperature for 6 hours. 2. The next day, mix the rose wine into the fermented seasonings and marinate for half an hour or above. Cut the pork into long pieces. 3. Add seasonings to pork and marinate for 45 minutes to 1 hour. 4. Place the marinated pork on the baking tray, place it in the middle layer of microwave steam oven, and select P06. 5. After baking is completed, take out the barbecued pork and apply the maltose that has been boiled and dissolved in water on the barbecued pork. 6. Place it in the microwave steam oven and bake in the "upper and lower grill" mode for 15 minutes. Take it out again. Coat the other side with maltose and continue baking for 15 minutes. 	middle layer
P10	Boiled Eggs	<p>4 eggs</p> <ol style="list-style-type: none"> 1. Place the eggs on steam tray, place the tray in the bottom layer of microwave steam oven and select P10. 	bottom layer
P11	Roasted Sweet Corns	<p>2 sweet corns</p> <p>Seasonings: 2 tbsp olive oil, 2 tsp cumin powder, 1 tsp cheese powder, 1 tsp salt, 1 tsp black pepper</p> <ol style="list-style-type: none"> 1. Divide the corn into 3 sections and cut each section into 4 pieces; 2. Mix the seasonings and set aside; 3. Lay the corns flat on baking tray and apply seasonings; 4. Place in the middle layer of the microwave steam oven and select P11. 	middle layer

Others

Recipe no.	Dish	Recipe	Accessory location
P12	Roasted Sweet Potatoes	3 sweet potatoes (about 100g each) 1. Clean the sweet potatoes and place them on baking tray; 2. Place the tray into the middle layer of microwave steam oven and select P12.	middle layer
P13	French Fries	Frozen French fries 200g 1. Frozen French fries do not need to be defrosted and poured into air fry basket. Lay the fries flat on the basket and try to avoid stacking; 2. Place the tray in the middle layer of microwave steam oven and select P13.	middle layer
P14	Small Buns	250g Bread flour, 3g Instant yeast, 5g salt, 18g sugar, 30g unsalted butter, 220ml milk 1. Soften unsalted butter at room temperature. 2. Mix bread flour, instant yeast, salt, sugar and milk to the mixer and mix for 20 minutes. 3. Add softened unsalted butter to the dough, and keep mix for about 15 minutes. 4. Cut the dough into 12 equal parts. 5. Put baking paper on bake tray and put 6 dough on the tray then put it in the bottom layer of the microwave steam oven and select P14.	bottom layer
P15	Pizza	250g High-gluten flour, 150ml water, 4g salt, 1/2g Instant yeast, red peppers, basil, cheese, grilled chicken 1. Dissolve salt in water, add 10% flour and mix well, then add Instant yeast and mix well. 2. Add the remaining flour in batches and knead into a round dough with your hands. 3. Cover the dough with a semi-dry wet cloth and let it rest for a while. 4. Deflate and roll it into a round shape, then place it in the refrigerator to let it ferment and double in size. 5. After taking the dough out of the refrigerator, it needs to be warmed for one hour. 6. Form into a 12-inch pizza shape, add red pepper, basil, cheese and grilled chicken. 7. Place the pizza on the baking tray, place it in the bottom layer of microwave steam oven, and select P15;	bottom layer
P16	Yogurt	750ml Pure milk, 50ml plain yogurt, 40g sugar 1. The cheese-making utensils must be scalded in boiling water and air-dried to ensure there is no oil or water; 2. Heat the pure milk to about 40 degrees, turn off the heat, heat the sugar and stir evenly; 3. When the temperature of the milk is lower than 40 degrees, add yogurt to make yeast and stir evenly; 4. Place the yogurt into a container for fermentation and seal with plastic wrap or lid; 5. Place it on the bottom layer of microwave steam oven and select P16.	bottom layer
P17	Blueberry Cream Cheese Cake	120g Blueberries, 2 eggs, 150g sugar, 50g vegetable oil, 1/2 tsp vanilla oil, 220g sour cream, 250g low-gluten flour, 1/2 tsp salt, 1/2 tsp soda powder, little cream cheese 1. Wash blueberries and set aside. 2. First put the eggs and sugar into a large bowl and beat with an electric egg beater until light yellow. Add vegetable oil and vanilla oil and mix well. Finally, add sour cream and mix into egg liquid. 3. Sift the cake flour, salt and baking powder through a sieve. 4. Add the sifted flour to the egg mixture, then add the blueberries. 5. Pour the egg mixture into the waffle mold, fill it to about 70% full, and add cream cheese. 6. Place the baking tray into the bottom layer of the microwave steam oven and select P17.	bottom layer

Others

Recipe no.	Dish	Recipe	Accessory location
P18	Apple Pie	<p>Ingredients for the dough: 90g unsalted butter, 1 tsp sugar , 3g salt, 180g all-purpose flour, 2 egg yolks, 2 tbsp ice water, 1 egg white.</p> <p>Filling: red & green apples 6 each, 1 tsp lemon juice, half lemon (in slice), nutmeg powder, 1 tsp golden cane sugar, a little walnut or almond slices, little dried cherries.</p> <ol style="list-style-type: none"> To make the pie, mix unsalted butter, sugar and salt until soft. Add all-purpose flour, mix briefly and add egg yolks and ice water. After kneading into a smooth dough, use rolling pin to gently flatten it into a square shape. Wrap with plastic cling and put into refrigerator for at least 1 hour. Take out the dough and let it sit at room temperature for 30 minutes. Then place the dough between 2 pieces of butter paper, roll it to 5 cm thick and tear off the butter paper. Place the dough into a 10-inch mold, prick holes with a fork, and apply white egg around the dough. Place the dough back in the refrigerator. To make the filling, wash and slice the red apples and green apples, add lemon juice, mix lemon juice, cardamom powder and golden cane sugar together, then cook over low heat until soft. Use a strainer to drain away the water and let cool. Use a rolling pin to crush the walnuts or almond slices lightly, then add the dried cherries; then pour into the filling and mix well. Take out the pie from the refrigerator, pour the filling evenly into pie, and wipe a little egg paste. Place the apple pie on baking tray and put it into the middle layer of microwave steam oven and select P18. 	middle layer
P19	Defrost chilled food (500g)		bottom cavity
P20	Semi-defrost thawed meat (500g)		bottom cavity
P21	Defrost thawed meat (500g)		bottom cavity

Operation Instructions

■ Residual Heat Indicator

In standby or energy-saving mode the  “Residual Heat Indicator” icon will be shown to warn that cavity exceed 50°C and is not suitable for cleaning. The icon will be off until cavity drops below 50°C. Users should not clean the appliance until the icon is off.

■ Child Lock

Steamer is equipped with child lock so that children cannot switch on or change any setting accidentally.

A. Activating the Child Lock:

Press and hold the  “Child Lock” button for 3 seconds. Child lock is enabled. The “Child Lock” icon lights up (as shown in the diagram below).



B. Cancelling the Child Lock:

Press and hold the “Child Lock” button for 3 seconds to disable the child lock function. The “Child Lock” icon goes off.

Cleaning and Maintenance

■ Cleaning and Maintenance

1. Under normal circumstances, cleaning is the only maintenance required.
2. Cleaning and maintenance should only be carried out when the combi steamer is cool and the  Residual Heat Indicator icon disappeared. Disconnect the power plug from the main power supply before cleaning. Do not use any steam cleaner to clean this appliance.
3. To avoid corrosion which would shorten the useful life of your combi steamer, always keep it clean. Always clean the appliance after use.
4. To avoid damage to the steam microwave oven body, control panel, oven walls and accessories, do not use any cleaning cloth that contains metal, scrubbing cleaners, steel brush or cloth with a rough surface for cleaning. Use a sponge or cloth soaked in gentle detergent or kitchen towel paper sprayed with glass cleaner to clean the appliance. Always make sure the cavity (including the bottom) is completely dried after use.
5. Salt is a corrosive substance that would result in rust stains if left to build up inside the oven. Acidic sauces, such as ketchup, mustard and preserves, contain chemicals like chlorine and acids which would damage the stainless steel surface.
6. Do not allow grease and food debris to remain on the oven door and door seal. If the door seal is not kept clean, the oven door may fail to close when the appliance is in operation. This would cause damage to the front and sides of the combi steamer.
7. After each use:
 - i) Empty the drip tray under the oven dooto prevent overflow, splash and soiling of the worktop. (The drip tray can be removed. It collects condensation water every time after use when door is opened
 - ii) Empty the water tank.
 - iii) Always leave the door opened for 15-30 minutes or run the Cavity Drying Mode to dry the oven and door frame.
8. If the oven is very dirty, run the Steam mode (110°C) to remove grease and dirt with steam for 30 minutes before cleaning. Do not start cleaning until the appliance has cooled down. For stubborn grease stains, repeat these steps several times. Never use any cleaning cloth that contains metal, scrubbing cleaners, steel brush or cloth with a rough surface for cleaning.
9. It is suggested to run the Descaling Mode at least once a month or when the descaling icon lights up.
10. Tap water, drinking water or distilled water is suggested for steaming function. Avoid using mineral water.
11. The water tank must be checked at least once a month. Clean it if necessary and put it back correctly.
12. Disconnect the main power if the appliance will not be used for a long period. Keep the oven clean and put the appliance in a dry place away from corrosive gases.
13. After every use, clean and air dry the oven (including the top, sides and bottom). If discoloration is detected at the bottom or inside the oven, remove the stains with a stainless steel cleaner (e.g. Wpro Steel Cleaner).

Cleaning and Maintenance

⚠ WARNING



Attention

Oven maintenance should only be carried out after unplugging the power plug, wait for the cavity cool down thoroughly.

Failure to do so may result in electric shock, injury or burns.

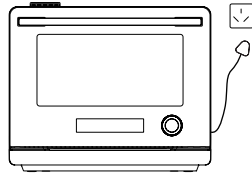

Do Not

Do not plug or unplug the power plug with wet hands Failure to do so may result in electric shock.

Failure to do so may result in electric shock.



Do Not

It is strictly prohibited to immerse the microwave steam oven in water or other in liquid

Failure to do so may result in electric shock or injury.

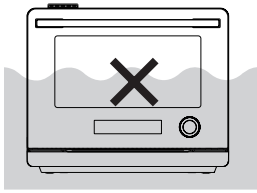

Do Not

Do not heat the oven if there is oil or food residue inside or on the door.

Microwaves will concentrate on dirty parts, which may cause dangers such as sparks, smoke, and fire. Additionally, rust will occur.

- If there is dirt on it, be sure to clean it every time after the oven cavity cools down.

⚠ CAUTION



Do Not

Do not use household detergents (alkaline, acidic, etc.), oven cleaners, powdered cleaners, styrene, diluent, bleach, hot water, flammable gas (LPG, etc.) spray cleaners, scouring pads, sponges Hard parts, metal cleaners, etc.

Sponge scouring pad



Do not use hard rough part to clean the appliance (Non-woven fabric with rough surface)

Please use the soft sponge part for cleaning

Rough surface scouring pad



Do not use this type of scouring pad for cleaning. Please use cleaning products with non-abrasive surfaces

Cleaning and Maintenance

■ Cleaning and Maintenance

Cavity

Wipe with a damp towel that has been wrung dry.

※ For dirt that is difficult to remove, please place a wet towel on the dirt for about 30 minutes and wait until the dirt softens before wiping; After steam cooking, please wait for the moisture condensed to cool down before wiping it with a towel;

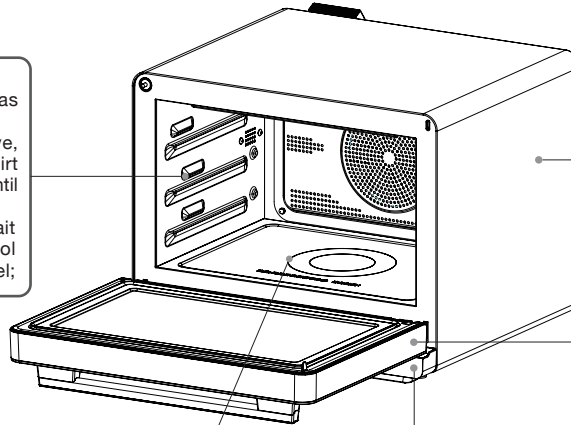

Body and oven door

Wipe with a damp towel that has been wrung dry.

※ When there is serious dirt, please use a towel with diluted kitchen detergent (neutral) to remove the dirt, and be sure to wipe the detergent away thoroughly.

Cavity bottom (ceramic glass)

Wipe the dirt on the bottom of the oven cavity immediately with a damp cloth.

The dirt caused by using microwaves may become burnt when baked. When the dirt is difficult to remove, please run the steam mode at 100°C for 20 minutes, and then wipe it off with a damp cloth.

The steam can penetrate into the underlying soil, making it easier to remove.

Do not use sharp objects, such as, steel brushes or forks to remove dirt, otherwise it may cause damage or cracks to the appliances.

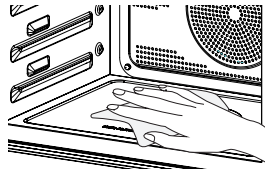

Drip tray and water tank

Wash with water and a soft sponge to remove dirt and dry thoroughly. If there is serious dirt, please clean it with diluted neutral detergent. Do not put it in a dishwasher, tableware dryer, or place it directly in the sun for drying, otherwise the water tank and drain plate may be deformed or damaged.

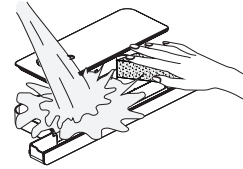

Others

■ Troubleshooting

A. Possible Problems



	Problem	Cause	Solution
1	No Display	Steam microwave oven is not connected to power supply	Ensure it is connected to power supply
		Malfunction of power socket	Check if other electrical appliances work normally
		Power cords is not working	Contact after-sales service
2	Steam microwave oven is not working	Power supply plug is not connected correctly	Try to plug in the power supply again
		Oven door is not closed properly	Close the oven door again
		Water tank is not in a correct position	Put the water tank back correctly
		Circuit board is damaged	Contact after-sales service
		Child lock is enabled	Disable the child lock
3	Display is not working properly	Display is damaged	Contact after-sales service
		Circuit board is damaged	
4	Lots of Water or steam can be found during cooking	Oven door is not closed tightly	Close the oven door tightly again
		Door seal is damaged	Contact after-sales service
5	Oven light is not working	Light is damaged	Contact after-sales service
		Control board is damaged	
6	Fan motor fails to work properly	Fan motor is damaged	Contact after-sales service
		Control board is damaged	
7	Control panel is not working properly	Control panel is out of order	Contact after-sales service
		Control board is damaged	
8	No steam	Water tube is damaged	Contact after-sales service
		Water pump is damaged	
		Water tank is empty or not in place	
9	Water leakage	The water tank is not in a correct position	Fill the water tank and put it back correctly

Others

B. Following conditions are normal

	Condition	Cause
1	Fame and smell can be detected during the first time of use	These are emitted by the protective oil and it is normal.
2	Noise can be heard using any steam related mode	This is normal during water pumping into machine for steaming.
3	Water condensation can be found around the ventilation vent or door	The steam microwave oven produces a large amount of steam under steam cooking mode. Most of the steam will be vented from the frontal ventilation and some condensation water will be found around the ventilation vent.
4	The fan continues to work after cooking is finished	The fan will continue to run for 3 minutes after each cooking mode for cooling purpose to discharge oven heat completely. It is normal.
5	White powder can be found around the air inlet	This is water scale. It is normal. If white powder (water scale) is detected, it is recommended to run the Descaling Mode for cleaning purpose.
6	Bottom and cavity of oven's color has yellowing.	Stainless steel will generate yellow marks when heated and not kept clean. It is recommended to clean the combi steamer after each use to avoid the yellowing issue caused.
7	Voltage fluctuations will affect the cooking effect	When the voltage fluctuates in the range of -10% to +5%, the microwave steam oven still can operate. However, affected by low or high voltage, the output power will decrease or increase relatively and affects the cooking effect, which is normal.

ENVIRONMENTAL HINTS

- * The packing box may be fully recycled as confirmed by the recycling symbol. Follow local disposal regulations. Keep potentially hazardous packaging (plastic bags, etc.) out of the reach of children.
- * This appliance is marked according to the European directive 2012/19/ EU on Waste Electrical and Electronic Equipment (WEEE). By ensuring this product is disposed of correctly, you will help prevent potential negative consequences for the environment and human health, which could otherwise be caused by inappropriate waste handling of this product. 
- * The symbol on the product, or on the documents accompanying the product, indicates that this appliance may not be treated as household waste. Instead it shall be handed over to the applicable collection point for the recycling of electrical and electronic equipment.
- * Disposal must be carried out in accordance with local environmental regulations for waste disposal.
- * For more detailed information about treatment, recovery and recycling of this product, please contact your local city office, your household waste disposal service or the shop where you purchased the product. 
- * Before scrapping, cut off the mains cord so that the appliance cannot be connected to the mains. 

Others

■ Product Specifications

Model	MWP329TBA, MWP329TSA, MWP329TMA
Rated Voltage and Frequency	220-240V~ 50/60Hz
Rated Input Power	2100W
Microwave Input Power	1500W
Microwave Operating frequency	2450 MHz
Product Dimension (H x W x D)	382 x 487 x 493mm
Cavity Dimension (H x W x D)	240 x 415 x 301.5mm
Oven Capacity	32L
Net Weight	Approximately 23.8kg



REGISTER YOUR PRODUCT ONLINE

For Australia Market



Scan QR Code to visit
www.whirlpool.com.au
to register your product warranty online.

This QR Code is only applicable to Australia.

You can download the user manual by

- Visiting our website www.whirlpool.com.au
- Contacting our Customer Service Center at 1300 363 344

For New Zealand Market



Scan QR Code to visit
www.whirlpool.co.nz
to register your product warranty online.

This QR Code is only applicable to New Zealand.

You can download the user manual by

- Visiting our website www.whirlpool.co.nz
- Contacting our Customer Service Center at 0800 442 584

Whirlpool® Registered Trademark/TM Trademark of Whirlpool group of companies

All rights reserved - <http://www.whirlpool.com.au>

- <http://www.whirlpool.co.nz>

EN

Whirlpool