



EN ■ User Manual

CZ ■ Uživatelská příručka

SK ■ Používateľská príručka

HU ■ Felhasználói kézikönyv

PL ■ Podręcznik użytkownika

Electric scooter

Elektrická koloběžka

Elektrická kolobežka

Elektromos roller

Hulajnoga elektryczna

Table of Contents

1. Package Contents and Scooter Description	3
1.1. Package contents	3
1.2. Description of SCOOTER S31	3
2.1. Control Panel and Application	4
2.2. Multifunction button.....	5
2.3. Driving modes	5
2.4. Starting Operating Mode.....	5
3. Assembling the electric scooter	7
4. Charging	8
5. Battery over-discharge protection	8
6. Folding and transport	9
7. Riding the electric scooter.....	10
8. Safety instructions	11
9. Maintenance and adjustment	12
10. Technical specifications	16

1. Package Contents and Scooter Description

1.1. Package contents

- 1x Electric SCOOTER S31
- 1x Charging adapter
- 1x Allen key
- 6x Handlebar mounting screws
- 1x User Manual
- 1x Tyre inflation adapter
- 4x side reflector
- 2x long spare screws for the footboard
- 2x short spare screws for the footboard

1.2. Description of SCOOTER S31

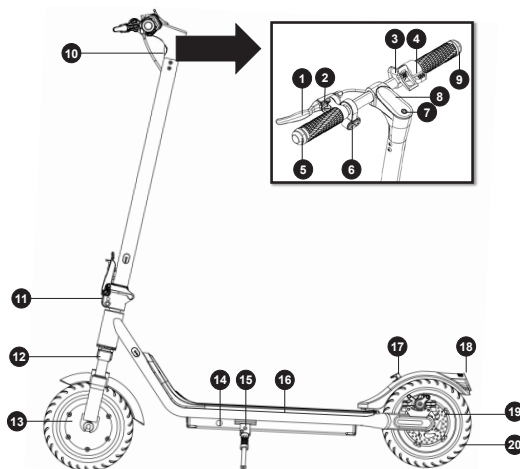

- | | |
|--|--|
| <ul style="list-style-type: none"> 1 Rear mechanical brake lever 2 Bell 3 Hook for securing in transport state 4 Speed controller 5 Left turn indicator 6 Buttons (left and right turn indicators) 7 On/Off/Multifunction button 8 Display 9 Right turn indicator 10 Front light 11 Release lever for folding mechanism 12 Front suspension fork | <ul style="list-style-type: none"> 13 Front wheel with inner tube, tyre for inflation, and electric motor 14 Charging connector 15 Stand (lowest point of the scooter body) 16 Footboard, battery compartment 17 Notch for securing the handlebar in folded state 18 Rear LED light / brake light 19 Rear mechanical disc brake 20 Rear wheel with inner tube and tyre for inflation |
|--|--|

2. Operation

2.1. Control Panel and Application

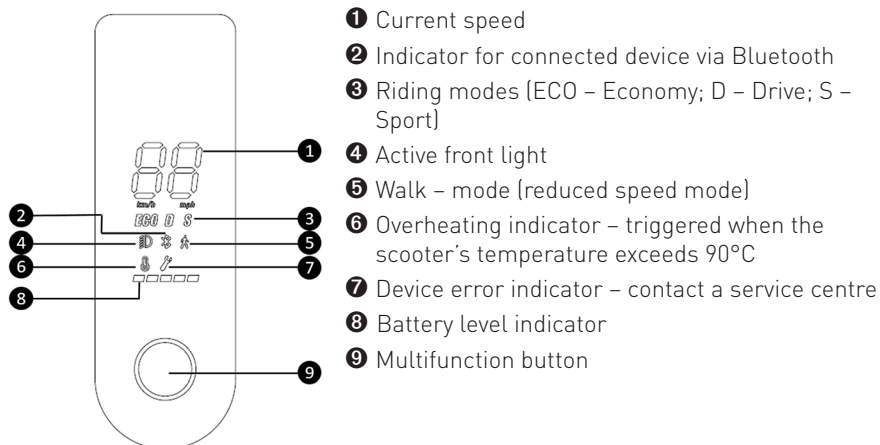

Settings via the Mobile App

SENCOR

HOME

This electric scooter can be set up via the SENCOR HOME app.

- Download the app to your smartphone, register and set up your electric scooter. If you already have the SENCOR HOME app installed, add your electric scooter to it.



- Instructions on how to use the application can be downloaded from <https://www.sencor.com/> in the SCOOTERS section
- Reset pairing with the SENCOR HOME app is done with the electric scooter switched on and the power button pressed 8 times in succession. A beep will sound to indicate a successful reset.

2.2. Multifunction button

**CAUTION:**

Always configure riding settings before beginning your ride.

- 1) When the scooter is powered off, press and hold the multifunction button to turn it on.
- 2) When the scooter is powered on, press and hold the multifunction button for 2 seconds to turn it off.
- 3) When the scooter is powered on, a short press of the multifunction button turns the LED front light on/off.
- 4) When the scooter is powered on, a quick double-press of the multifunction button switches between riding modes.
- 5) When the scooter is powered on, a quick triple-press of the multifunction button toggles the speed units on the display (km/h or mph).

2.3. Driving modes

Switch between modes by double-clicking the multi-function button.

Walk	up to 6 km/h
Eco	up to 10 km/h
Drive	up to 20 km/h
Sport	up to 25 km/h

2.4. Starting Operating Mode

- 1) Switch on the electric scooter.
- 2) Fully press and hold down the speed control until 16 shows on the display.
- 3) Keep holding down the speed control and simultaneously press the brake lever.
- 4) Release the brake lever.
- 5) This will switch to the last set mode.

**CAUTION:**

Always activate operating mode when the electric scooter is stationary. Start the scooter by following the instructions step by step and slowly.

Controlling the turn lights

- The turn indicator control is located on the left side of the handlebars, see ⑥ on the main diagram. Once activated, the light will turn off automatically after a while or can be turned off manually by pressing the same button.
- Pressing the right button activates the turn light on the right end of the handlebars.
- Pressing the left button activates the turn light on the left end of the handlebars.

Replacing the turn lights

Take extra care when storing and putting away the electric scooter to avoid dropping it on objects that could damage the turn lights at the end of the handlebars. If a turn light gets damaged, new lights can be purchased as a separate part. To replace a turn light, loosen the 1.5mm Allen bolt located underneath the handlebars. Pull the turn light out and disconnect it at the connector. Connect the new turn light and cover the connector with the new protective tape. Insert the turn light into the handlebar tube and gently tighten the 1.5mm Allen bolt.

3. Assembling the electric scooter

1. Straighten the handlebar rod and secure it firmly with the lock lever.

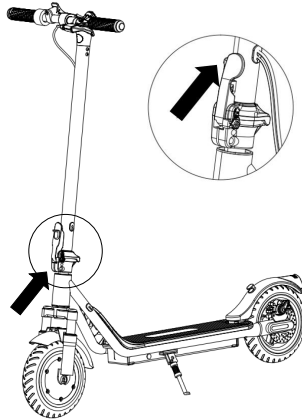

2. Make sure that the control unit connectors are connected to the control panel. The wires must be properly connected to prevent them from coming loose later on.

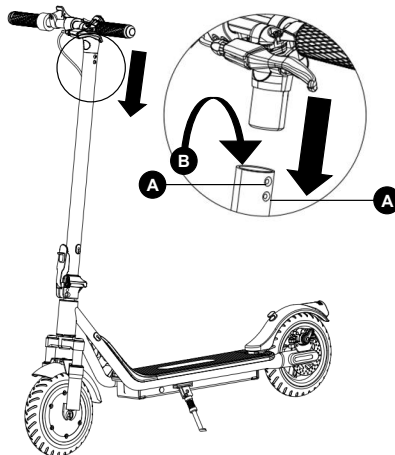

3. Carefully connect the handlebar with the handlebar tube. Take care not to damage the connecting wire when inserting it into the handlebar tube. The LED light must point in the direction of travel.

4. Screw the handlebar and the handlebar tube together. Insert two Allen screws **A** from the left side and two Allen screws **B** from the opposite side, as shown in the diagram. Tighten the screws firmly. Regularly check that the screws have not come loose during use.
5. Switch on the electric scooter.

4. Charging

Before starting your ride, ensure the battery is fully charged. Switch on the control panel and check the battery level.

Charge the scooter with the supplied charging adapter. First, uncover the rubber cap of the charging connector **14** on the scooter and connect the charging adapter. Then connect the adapter to your power outlet. When the charging process is finished and the charging adapter is disconnected, cover the charging connector opening again with the rubber cap. Regularly check that the protective cap covers the charging connector when not charging.

The charging adapter includes a indicator displaying two states.

1. **Red LED:** Indicates that the battery is charging
2. **Green LED:** Indicates that the battery is fully charged



CAUTION:

Only use the original accessories provided in the package for charging. If the battery life becomes very short, it is a sign that the battery's lifespan has been consumed. It is recommended to have the battery replaced at an authorised service centre.

Recommendation:

If the unit is not to be used for an extended period of time, we recommend to fully charge the battery once every two to three months. We do not recommend storing the unit with a flat battery to prevent irreparable damage to the battery (loss of capacity).

5. Battery over-discharge protection

Each component of the electric scooter is protected against damage caused by operational overload and lower battery charging level.

1. If the scooter is subject to a higher load for example due to frequent riding uphill or riding up a steep hill, the control unit/battery overheating protection will be enabled, limiting the power for a necessary period of time. The speed will be reduced to a maximum of 15 km/h.

- If the battery level drops below 30%, the maximum scooter speed will be limited to max. 15 km/h. If the battery level drops below 25%, the maximum speed will be limited to max. 10 km/h.

**CAUTION:**

Do not repair and/or tamper with the electric scooter (SCOOTER S31) protection mechanisms. This will help prevent damage to individual components of the scooter.

6. Folding and transport

- Ensure the electric scooter is turned off. Hold the scooter steady, unlock the folding mechanism release lever at the bottom of the handlebar tube, and flip the lever forward in the direction of travel.



- Fold the loosened handlebar tube towards the rear mudguard, securing it using the hook **3** on the handlebars and the notch **17** on the rear mudguard.
- To carry the scooter, hold it by the handlebar tube. To make the scooter easier to carry, we recommend holding the handlebar tube one third of the way along on the side near the front wheel.

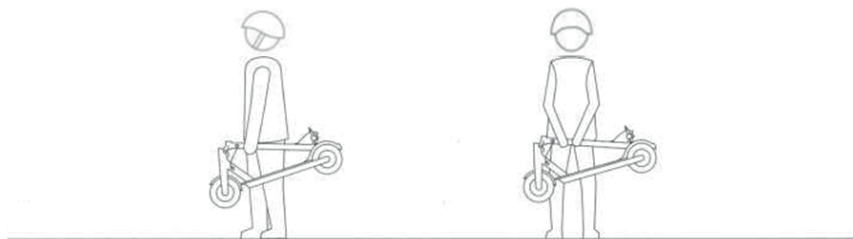

7. Riding the electric scooter

**CAUTION:**

- Before each ride, always put on a helmet and protectors to prevent injury.
- Before each ride, always check that the mechanical brake is fully functional.

1. Place one foot on the scooter footboard and gently push off with the other foot.

**CAUTION:**

Always push off with your foot on the opposite side to the stand **15**.

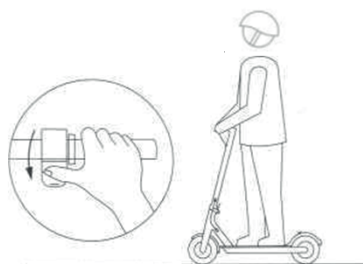

2. Once the scooter is in motion, press the speed control lever **4** to activate the motor. When the scooter starts moving under its own power, place the other foot on the footboard **16**.

Note:

The motor will start and the scooter's speed can be controlled once it reaches a minimum speed of 5 km/h.

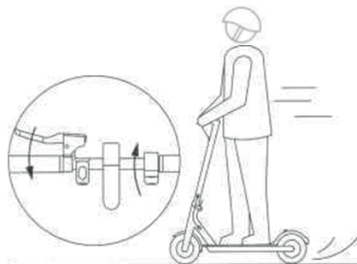

3. Stopping is essential for safe driving. First, release the speed controller ④ and then press the mechanical brake ① located on the left side of the handlebars.
4. Try the first turns slowly and on a flat surface. To turn, shift your centre of gravity slightly. Gently lean in the direction you want to go and slowly turn the handlebars.

8. Safety instructions

This electric scooter is designed for fun and recreational use. It is not a means of transport. Be considerate of others in both private and public areas, follow the instructions below as well as local traffic regulations.

When meeting pedestrians, pay close attention to your ride and make sure pedestrians are aware of

your presence. If you are outside their angle of view, ring the bell, slow down and overtake (in right-hand traffic, overtake from the left).

Faster speeds automatically mean a longer braking time. Keep at a safe speed in case you unexpectedly need to stop, and keep a safe distance from others. Even on a flat surface, you may encounter situations or terrain that cause you to lose balance, skid or other unexpected situations that can cause you to fall. Always pay close attention when riding.

Check the mechanical brake, battery charge status, wear of components and wheels before each ride. If any parts are loose or you hear an unusual noise, carry out a thorough check and contact an authorised service centre if necessary.

Neither the manufacturer nor the distributor are liable for any financial damages, injuries, accidents, legal disputes or conflicts resulting from failure to observe the safety instructions.

- Do not ride in the rain and avoid slippery surfaces.
- If you encounter an obstacle on your way, stop and carry the scooter over the obstacle.
- Exercise caution when passing through low ceilinged areas.
- Do not accelerate downhill and always brake well in advance.
If you encounter a steep descent (e.g. a steep hill), dismount and walk with your scooter.
- Do not add speed while pushing the scooter.
- Always avoid obstacles.
- Avoid carrying heavy luggage on the handlebar.
- Always keep both feet on the scooter footboard while riding.
- Use the scooter only in designated areas. Observe the local regulations of the regions, parks, cities and states you are riding in.
- Do not turn sharply at high speeds.
- Do not ride through puddles, water or in rain.
- Do not ride with another person, even a child.
- Do not step on the mudguards.

- Do not touch the brake components.
- Always hold on to the handlebars.
- Do not try to ride up the stairs, down the stairs or jump with your scooter.
- Remember that the stand is the scooter's lowest point. Take care to prevent it from catching on elevated surfaces while riding.

9. Maintenance and adjustment

Regular maintenance and correct adjustment of all parts of the electric scooter prolongs its lifespan. Clean the individual components of the electric scooter with a damp cloth and apply a preservation oil (excluding brake discs and pads).

Before each ride, check that all removable parts are tightly attached. If any screws, Allen screws, or nuts are loose, tighten them with the appropriate tool.

The brake mechanism must be adjusted before the first ride. Contact a specialised provider (e.g. a bike service) to have it adjusted properly. Adjustments cannot be made under warranty or post-warranty service at the manufacturer or distributor.



CAUTION:

Never use a high-pressure washer on the electric scooter.

Adjusting the brake – If the brakes are too tight or too loose, use a 4 mm Allen key to loosen the brake mechanism screw (counterclockwise) and adjust the brake cable length as needed. Then tighten the screw firmly. Further fine-tune the brake cable tension using the nut on the mechanical brake mounted on the handlebars. Regularly inspect the brake pads for wear and replace them as necessary. Brake pads are consumable parts that degrade with use. Keep the entire braking system clean and avoid greasy deposits on the brake disc and pads.



Handlebar Joint Adjustment – When in the folded position, a 4 mm Allen screw **C** is accessible on the handlebar joint for tightening its attachment. Before tightening the Allen screw in the handlebar tube joint, first loosen the screws on the clamp (indicated by arrows in diagram **B**). Tighten the joint fitting gently to ensure that the steering is not rigid and that there is as little slack in the joint fitting as possible. After adjustment, align the handlebars and securely tighten the screws **B**. Whenever the steering gets looser after riding, tighten the components following this procedure.

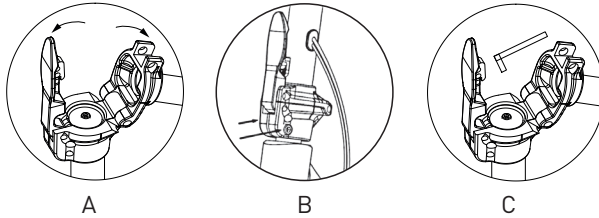

Adjusting the folding mechanism lever - if the folding mechanism becomes loose, it needs adjusting. The adjustment screw fits into the folding mechanism lever and is located at the bottom of the handlebar tube. Fold the handlebars into the transport position and eliminate the play by loosening the Allen screw (turn counterclockwise). Loosen the screw gradually and repeatedly test unfolding the scooter until the lever's locking mechanism is firm enough. Never loosen the screw to the extent that the folding mechanism lever can only be locked with excessive force.

Suspension - the scooter is equipped with front suspension that is optimally preset from the factory and cannot be changed.

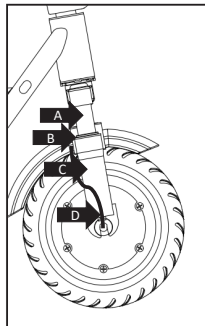

Keep the sliders and scraper shaft seals of the front suspension fork clean and dry. Take care to avoid excessive wear and damage to the glider surface. Use a dampened cloth for cleaning. After wiping off the dirt, use preservative oil to wipe the gliders. For long life we recommend cleaning and preserving the front gliders after every ride. In the lower right part of the suspension fork there are the motor supply wires. Take extra care when riding and transporting your electric scooter to avoid mechanical damage to the supply wires.

- A – glider
- B – scraper shaft seal
- C – lower part of suspension fork
- D – power supply lead

Wheel and Tyre Inspection – The wheels of the electric scooter are inflatable and equipped with inner tubes. Regularly check the condition of the tyres. If the tyres show damage or excessive wear from use, replace them immediately.



CAUTION:

The correct tyre size and pattern prescribed by the manufacturer must always be observed. Do not attempt to change the tyres without professional assistance.

Before each ride, check the air pressure in the tyres. The air pressure must be between **2.2** and **2.4 bar**. If the tyre pressure is lower, use a pump with a Schrader valve fitting to inflate it as necessary. If the pressure is higher, deflate it to the recommended level.

Removing the front wheel

List of tools:

18 mm wrench

Remove the plastic nut covers. Use an 18 mm spanner to loosen the nuts **B** of the front wheel on the suspension fork. Disconnect the wires **A** connected to the motor on the right side of the suspension fork.

Then pull the wheel down and out **C**.

For reassembly, follow the reverse order, ensuring the wheel is reassembled as it was before disassembly.



CAUTION:

Perform all tasks carefully to avoid damaging the individual parts. When assembling, ensure that all parts are properly in place and that all connecting nuts and screws are securely tightened. Exercise extra caution when handling the front wheel near the motor wire connection area. The motor wire cannot be disconnected. If you are unsure about assembly or disassembly, contact a specialised service centre. The replacement of tyres and inner tubes is not covered under warranty repair.

* Use only cleaning agents that do not corrode the materials used.

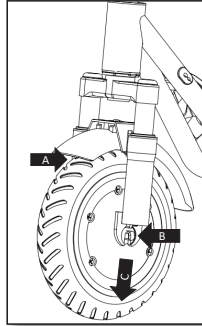

Removing the rear wheel

List of tools:
 4 mm Allen key
 5 mm Allen key
 hair dryer

Use a hair dryer to heat and peel off the reflector **A**. Unscrew the Allen screws **B** and remove the plastic covers of the rear wheel on both sides. Unscrew the Allen screw **C** from both sides of the rear wheel and pull the wheel backward **D**.



CAUTION:

Perform all tasks carefully to avoid damaging the individual parts. When assembling, pay attention to precision and ensure that all connecting screws are securely tightened. If you are unsure about assembly or disassembly, contact a specialised service centre. The replacement of tyres and inner tubes is not covered under warranty repair.

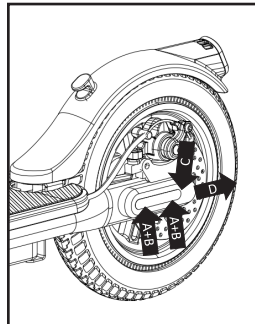

10. Technical specifications

SCOOTER S31

Key features

Engine power 350 W

Maximum speed up to 25 km/h

Travel range up to 25 km

SENCOR SCOOTER app available at Google Play and APP Store

Front and rear LED light

LED display (mode, speed, battery, lighting, Bluetooth)

Turn signal lights

Drive

Engine power 350 W

Speed:

- SPORT mode up to 25 km/h

- DRIVE mode up to 20 km/h

- ECO mode up to 10 km/h

- WALK mode up to 6 km/h

Range up to 25 km at a weight of 70 kg

Cruise control

Maximum pitch angle up to 15°

Wheels

10-inch front and rear inflatable tyres

Dual braking system - electrical and mechanical

Disc brake

SENCOR HOME App

Available at Apple App Store and Google Play

Scooter locked using the app

Bluetooth 5.0

Technical specifications

Maximum load: 120 kg

Dimensions: 107 x 49 x 120 cm (unfolded)

Dimensions: 107 x 49 x 53 cm (folded)

Weight: 13.5 kg

Working temperature: 0 to 40 °C

Storage temperature: 0 to 45 °C

Noise level < 70 dB(A)

Charging adapter

Input voltage: 100–240 V AC 50/60 Hz

Input current: 1.5 A

Output voltage: 42 V

Connector: Φ 5.5 x 10 mm

Battery

Capacity: 270 Wh – 7.5 Ah/36 V Li-ion

Charging time: max. 6 hours

Protection against: short circuit, overvoltage, overcharging, overheating

Battery discharge protection

Charging adapter	Value and Accuracy	Unit
Manufacturer's name or trademark, company ID and address	"Dongguan Green Power One Co., Ltd No.26, Hongyun Street, Chonghe Village, Qingxi Town, Dongguan City, Guangdong, P. R. China"	-
Model identification code	GA20-4201500T	-
Input voltage	100–240	V
Input frequency	50/60	Hz
Output voltage	42.0	V
Output current	1.5	A
Output power	63.0	W
Average efficiency in active mode	89.61	%
Low load efficiency (10%)	/	%
No load power consumption	0.19	W

Bluetooth

Version	5.0
Maximum transmitter power	100 mW at 2.4 GHz – 2.4835 GHz

Noise Emissions

The weighted sound pressure level of a moving vehicle is less than 70 dB (A).

INSTRUCTIONS AND INFORMATION ON DISPOSAL OF USED PACKAGING MATERIAL

Take the packaging material to a designated municipal waste facility.



DISPOSAL OF USED ELECTRICAL AND ELECTRONIC EQUIPMENT

This symbol on products or original documents means that used electric or electronic products must not be added to standard municipal waste. For proper disposal and recycling, take these products to designated collection points. Alternatively, in some European Union states or other European countries the products can be returned to the local retailer when buying an equivalent new product. Correct disposal of this product helps save valuable natural resources and prevents damage to the environment caused by improper waste disposal. Ask your local authorities or collection facility for more details. Fines may be imposed for the improper disposal of this type of waste as per national regulations.

For business entities in European Union States

If you want to dispose of electric or electronic devices, ask your retailer or supplier for the necessary information.

Disposal in other countries outside the European Union

This symbol is valid in the European Union. If you wish to dispose of this product, request the necessary information about the correct disposal method from the local council or from your retailer.



This product meets all the basic requirements of EU directives that apply to it.

Changes in the text, design and technical specifications may be made without prior notice and we reserve the right to make such changes.

SENCOR®

EN Warranty conditions

Warranty card is not a part of the device packaging.

This product is warranted for the period of 24 months from the date of purchase to the end-user. Warranty is limited to the following conditions. Warranty is referred only to the customer goods using for common domestic use. The claim for service can be applied either at dealer's shop where the product was bought, or at below mentioned authorized service shops. The end-user is obligated to set up a claim immediately when the defects appeared but only till the end of warranty period. The end user is obligated to cooperate to certify the claiming defects. Only completed and clean (according to hygienic standards) product will be accepted. In case of eligible warranty claim the warranty period will be prolonged by the period from the date of claim application till the date of taking over the product by end-user, or the date the end-user is obligated to take it over. To obtain the service under this warranty, end-user is obligated to certify his claim with duly completed following documents: receipt, certificate of warranty, certificate of installation.

This warranty is void especially if apply as follows:

- Defects which were put on sale.
- Wear-out or damage caused by common use.
- The product was damaged by unprofessional or wrong installation, used in contrary to the applicable instruction manual, used in contrary to legal enactment and common process of use or used for another purpose which has been designed for.
- The product was damaged by uncared-for or insufficient maintenance.
- The product was damaged by dirt, accident of force majeure (natural disaster, fire, and flood).
- Defects on functionality caused by low duality of signal, electromagnetic field interference etc.
- The product was mechanically damaged (e.g. broken button, fall).
- Damage caused by use of unsuitable media, fillings, expendable supplies (batteries) or by unsuitable working conditions (e.g. high temperatures, high humidity, quakes).
- Repair, modification or other failure action to the product by unauthorized person.
- End-user did not prove enough his right to claim (time and place of purchase).
- Data on presented documents differs from data on products.
- Cases when the claiming product cannot be indentified according to the presented documents (e.g. the serial number or the warranty seal has been damaged).

Manufacturer:

FAST ČR, a.s., U Sanitasu 1621, Říčany 251 01, Czech Republic
info@sencor.com

Authorized service centers:

Visit www.sencor.com for detailed information about authorized service centers.

The original version of the instructions is in the Czech language, other language versions are made by the appropriate translation.

FAST®

FAST ČR, a.s.

 U Sanitasu 1621, 251 01 Říčany, Czech Republic
 tel.: +420 323 204 111, fax: +420 323 204 110

EU DECLARATION OF CONFORMITY

Product / brand: ELECTRIC SCOOTER / SENCOR

Type / model: SCOOTER S31 as factory model M2

 DC 36,0V (Li-ion battery 7,5Ah); IPX5; Class III; L_{WA} = 65dB(A)
 Freq.: 2402-2480MHz; max. output power 1,205mW
 Adapter (GA20-4201500T)
 Input AC 100-240; 50/60 Hz; 1,8A; Class II; IP20
 Output DC 42,0V; 1,5A; 63,0W

Manufacturer: FAST ČR, a.s.

 U Sanitasu 1621, 251 01 Říčany, Czech Republic
 VAT no: CZ24777749

Person in charge of completing the technical documentation: FAST ČR, a.s.

This declaration of conformity is issued under the sole responsibility of the manufacturer.
The object of the declaration described above is in conformity with the relevant Union harmonisation legislation:

Directive MD 2006/42/EC	Directive LVD 2014/35/EU	Directive ErP 2009/125/EC
Directive RED 2014/53/EU	Directive EMC 2014/30/EU	Directive NEOE 2000/14/EC
Directive RoHS 2011/65/EU+(EU)2015/863		

The relevant harmonised standards and the other technical specifications:

EN 60335-1:2012+AC+A11+A13+A14+A14+A2+A15	EN IEC 61558-1:2019
EN IEC 62368-1:2020+A11	EN 62233:2008+AC
EN 17128:2020	EN ISO 12100:2010
EN 62479:2010	EN 55032:2015+A1+A11
EN 301 489-1 V2.2.3	EN 301 489-17 V3.2.6
EN IEC 55014-1:2021	EN IEC 55014-2:2021
EN IEC 61000-3-2:2019+A1	EN 61000-3-3:2013+A1+A2
	EN 61558-2-16:2009+A1
	EN 55035:2017+A11
	EN 300 328 V2.2.2

Place of issuance: Říčany

Date of issuance: 20. 11. 2025

Name: Ing. Luboš Cinek (Responsible person)

Signature:

FAST ČR, a.s.
 U Sanitasu 1621, 251 01 Říčany
 tel.: +420 323 204 111
 IČO: 247 77 749, DIČ: CZ 247 77 749

IČO: 24777749, DIČ: CZ24777749

 Bankovní spojení: Komerční banka Praha 1, č.ú. 89309011/0100, ČSOB Praha 1, č.ú. 8010-0116233383/0300
 Česká spořitelna Praha 4, č.ú. 2375682/0800

FAST ČR, a.s., U Sanitasu 1621, Říčany CZ-251 01