

lěvoit®

LSV-V222-DUSR

VortexIQ Pro Cordless Stick Vacuum



User Manual

Table of Contents

Package Contents	2
Specifications	2
Safety Information	3
Getting to Know Your Vacuum	6
Controls	7
Using Your Vacuum	7
Care & Maintenance	9
Cleaning	12
Storage	15
Troubleshooting	16
Warranty Information	18
Customer Support	19

Package Contents

- 1 × Vacuum Body
- 1 × Long Stick
- 1 × Short Stick
- 1 × Vacuum Head
- 1 × 2-in-1 Crevice Tool
- 1 × Mini Motorized Brush
- 1 × Charging Dock
- 3 × Screw
- 3 × Wall Anchor
- 1 × Charger
- 1 × User Manual

Specifications

Model	LSV-V222-DUSR	
Battery Input	25.2V  2,500mAh Li-ion battery	
Rated Power	285W*	
Charging Input	100–240V~ 50/60Hz 0.8A	
Charging Time	3–4 hours	
Dimensions	9.8 x 7.7 x 43.3 in / 25 x 19.5 x 110 cm	
Weight (Vacuum Body + Battery)	3.5 lb / 1.6 kg	
Dust Bin Capacity	3.6 cups / 0.85 L (Max)	
Runtime** (Using Vacuum Head or Mini Motorized Brush)	ECO (I)	40 minutes
	MID (II)	25 minutes
	TURBO (III)	12 minutes
Runtime** (Using Crevice Tool)	ECO (I)	60 minutes
	MID (II)	25 minutes
	TURBO (III)	10 minutes
Suction Power	110AW*	
Battery Operating Conditions	Charging Temperature: 32°–116.6°F / 0°–47°C Storage Temperature: –4°–77°F / –20°–25°C Storage Humidity: ≤ 60%	

*May vary +/- 6%

**Tested at room temperature

Exception: The international symbol for the nature of supply  may be used instead of "DC" if the significance of this symbol is explained in the instructions packaged with the product. When this symbol is used it shall be placed next to the marking for rated voltage.

IMPORTANT SAFETY INSTRUCTIONS

When using this vacuum, basic precautions should always be followed, including the following:

READ ALL INSTRUCTIONS BEFORE USING THIS APPLIANCE

WARNING – To reduce the risk of fire, electric shock, or injury:

- **CAUTION:** Risk of injury. Roller brush may start unexpectedly. Remove battery pack before cleaning or servicing.
- **Do not** leave the vacuum unattended while it is on. Unplug from outlet when not charging and before servicing.
- **Do not** use outdoors or on wet surfaces.
- Children shall not play with the vacuum.
- **Do not** allow to be used as a toy. Close attention is necessary when used by or near children.
- This vacuum is not to be used by persons (including children) with reduced physical, sensory, or mental capacities, or lack of experience and knowledge, unless they have been given supervision or instruction concerning the use of the appliance by a person responsible for their safety.
- Children should not clean or perform maintenance on the vacuum without supervision.
- **Only** use the vacuum as described in this manual.
- Use **only** the manufacturer's recommended attachments.
- **Do not** use your vacuum if it is damaged or not working correctly, or if the charger or plug is damaged. **Do not** try to repair it yourself. Contact **Customer Support** (see page 19).
- **Do not** handle the charger or vacuum with wet hands.
- **Do not** put any object into any opening. **Do not** use the vacuum with any opening blocked. Keep free of dust, lint, hair, or anything that may reduce airflow.
- Keep hair, loose clothing, fingers, and all body parts away from openings and moving parts.
- Use extra care when cleaning on stairs.
- **Do not vacuum the following** (or use where they may be present):
 - Sharp objects such as glass shards, metallic nails, metal paper clips, or pins;
 - Ultrafine particles such as lime, cement, sawdust, gypsum powder, or ashes;
 - Hazardous materials or chemicals such as solvents, drain cleaner, strong acids, or strong alkalis.
- **Always** turn the vacuum off before connecting or disconnecting the stick, nozzles, brushes, or vacuum head.
- **Do not** vacuum water or any liquids.
- **Do not** vacuum anything that is burning or smoking, such as cigarettes, matches, or hot ashes.

Safety Instructions (cont.)

- **Do not** use to pick up flammable or combustible liquids, such as gasoline, or use in areas where they may be present.
- **Do not** use without dust bin and/or filters in place.
- **Do not** point the vacuum at any person or animal while it is on.
- Store the vacuum on a small stand or hang it from the wall.
- **Do not** use the vacuum in temperatures above 116.6°F (47°C) or below 32°F (0°C).

BATTERY & CHARGER

WARNING: Read all safety warnings and instructions. Failure to follow the warnings and instructions may result in electric shock, fire, and/or serious injury.

- **Do not** pull or carry the vacuum by the charging cable, use the cable as a handle, close a door on the cable, or pull the cable around sharp edges or corners. **Do not** run any appliance over the cable.
- Prevent unintentional starting. Ensure the switch is in the off position before connecting to battery pack, picking up or carrying the appliance. Carrying the appliance with your finger on the switch or energizing appliance that have the switch on invites accidents.
- Disconnect the battery pack from the appliance before making any adjustments, changing accessories, or storing appliance. Such preventive safety measures reduce the risk of starting the appliance accidentally.
- **Do not** unplug by pulling on cord. To unplug, grasp the plug, not the cord. Turn off all controls before unplugging.
- **Never** place the charger or its cable near any heat source.
- Keep the charging cable out of areas where people walk often. Place the cable where it will not be tripped over.
- **Do not** use the charger to charge other appliances besides this vacuum.
- **Only** recharge the vacuum with the charger specified by Vesync (US) Corporation. A charger that is suitable for one type of appliance may create a risk of fire when used with a different battery pack. For use **only** with the ZD024X310088US adapter manufactured by E-TEK Electronics Manufactory Co., LTD. For more information, please contact **Customer Support** (see page 19).
- **Only** use the battery pack specifically designed for this vacuum. Use of any other battery packs may create a risk of injury and fire. For use **only** with the LSV-V222B-DUSR battery pack manufactured by Suzhou Kais Power Co., Ltd. For more information, please contact **Customer Support** (see page 19).
- When the battery pack is not in use, keep it away from other metal objects, like paper clips, coins, keys, nails, screws, or other small metal objects that can make a connection from one terminal to another. Shorting the battery terminals together may cause burns or a fire.

- Under abusive conditions, liquid may be ejected from the battery. Avoid contact. If contact occurs, flush with water. If liquid contacts eyes, immediately flush with water and seek medical help. Liquid ejected from the battery may cause irritation or burns.
- **Do not** use the battery pack or vacuum if they are damaged or modified. Damaged or modified batteries may exhibit unpredictable behavior resulting in fire, explosions, or risk of injury.
- Have servicing performed **only** by a qualified repair person using identical replacement parts. This will ensure that the safety of the vacuum is maintained.
- **Do not** modify or attempt to repair the vacuum or the battery pack except as indicated in the manual.
- **Do not** expose the battery pack or vacuum to fire or excessive temperatures. The battery used in this device may present a risk of fire or chemical burn if mistreated. **Do not** disassemble, short contacts, heat above 140°F (60°C), or incinerate. Exposure to fire or temperatures above 266°F (130°C) may cause an explosion.
- Follow all charging instructions and **do not** charge the battery pack or vacuum outside of the temperature range specified in the instructions. Charging improperly or at temperatures outside of the specified range may damage the battery and increase the risk of fire.
- **WARNING: Do not** use with non-rechargeable batteries.

SAVE THESE INSTRUCTIONS

**NOT FOR COMMERCIAL USE
HOUSEHOLD USE ONLY**

Getting to Know Your Vacuum

- A. On/Off Button
- B. Suction Level Button
- C. Vacuum Body
- D. HEPA Filter
- E. Felt Filter
- F. Foam Filter
- G. Metal Filter
- H. Dust Bin
- I. Lid Release Button
- J. Vacuum Head Release Button
- K. Vacuum Head
- L. LED Light
- M. Vacuum Handle
- N. Battery Indicator Lights
- O. Battery Release Button
- P. Battery
- Q. Dust Bin Release Button
- R. Vacuum Body Release Button
- S. Short Stick
- T. Long Stick
- U. Mini Motorized Brush
- V. Roller Brush Release Button
- W. Roller Brush
- X. Charging Port (on the battery)
- Y. Charging Dock
- Z. Charger
- AA. Screws
- AB. Wall Anchors
- AC. 2-in-1 Crevice Tool

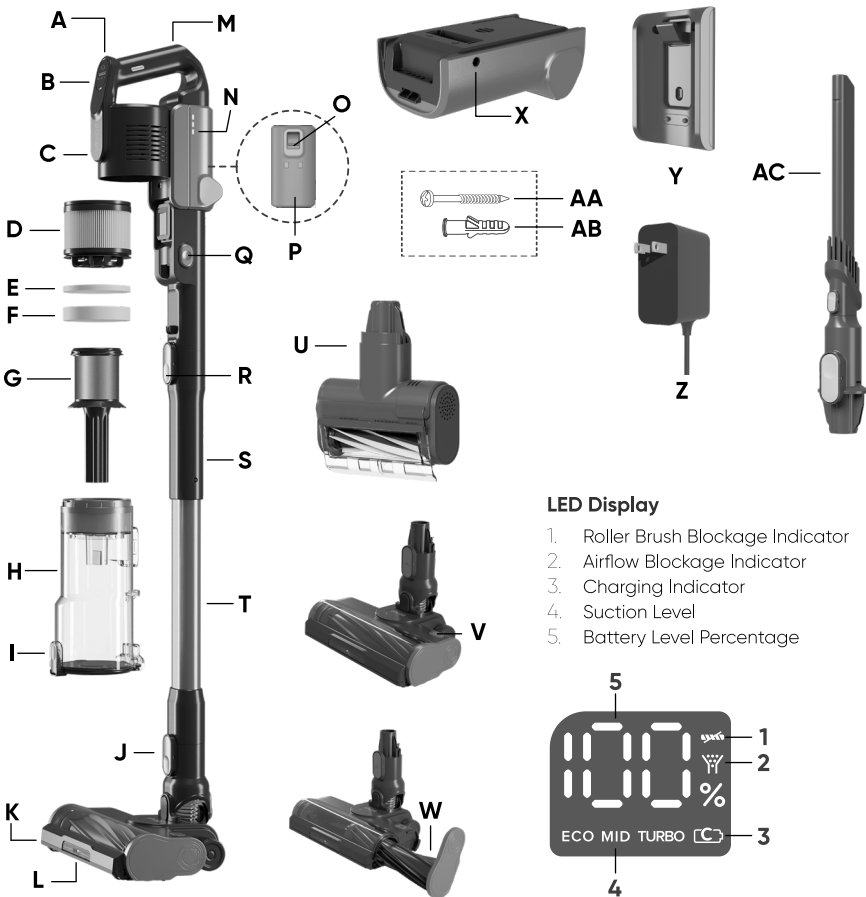

LED Display

1. Roller Brush Blockage Indicator
2. Airflow Blockage Indicator
3. Charging Indicator
4. Suction Level
5. Battery Level Percentage

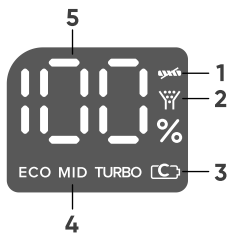

Controls



On/Off Button

- Turns the vacuum on/off.

Suction Level Button

- Cycles through suction levels: ECO (I), MID (II), and TURBO (III).
- The vacuum will default to ECO (I). Press once for MID (II) and twice for TURBO (III).
- ECO (I) is suitable for daily cleaning.
- MID (II) is suitable for deep cleaning.
- TURBO (III) is suitable for tough tasks.

Battery Indicator Lights

- Indicate the battery level when you are using the vacuum.

Battery Indicator Light Chart (During Use)

Battery Level	Battery Indicators
70–100%	■ ■ ■
35–70%	■ ■ □
10–35%	■ □ □
0–10%	⚡ □ □

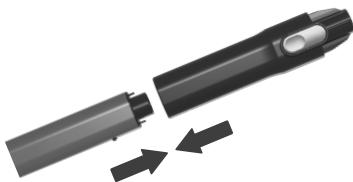

Figure 1.1

Using Your Vacuum

1. Build the vacuum stick by aligning the dots on the long stick and short stick, then push together until they lock in place. **[Figure 1.1]**
2. Attach the vacuum head or a nozzle attachment to the bottom of the stick, then attach the vacuum body to the top of the stick. **[Figure 1.2]**

Note: There is a clicking sound when the parts are properly joined together.

3. Charge the vacuum (see page 9).

Note: Fully charge the battery before first use.



4. Press  to turn the vacuum on. The vacuum will default to ECO (I).
5. Press the Suction Level Button to adjust the suction power.
6. Press  to turn the vacuum off.



Figure 1.2

Using Your Vacuum (cont.)

NOZZLE ATTACHMENTS

Your vacuum comes with nozzle attachments to help you tackle almost any cleanup job.

2-in-1 Crevice Tool

- Press button to slide bristles up/down and switch between crevice tool and dusting brush. **[Figure 1.3]**
- Use the crevice tool to clean hard-to-reach places like crevices in furniture and corners of a room or car.
- Use the dusting brush to clean dust and hard surfaces like mantels or baseboards.

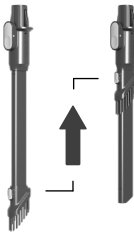

Figure 1.3

Mini Motorized Brush

- Good for tight spaces and delicate fabric surfaces, such as a bed, sofa, or carpeted stairs. **[Figure 1.4]**
- Powerfully cleans dirt and pet fur from carpet, upholstery, mattresses, and more.



Figure 1.4

To use a nozzle attachment:

1. Press and hold the Vacuum Body Release Button and gently pull the vacuum body from the stick.

2. Slide the nozzle attachment onto the vacuum body. **[Figure 1.5]**
3. Optionally, leave the stick attached to the vacuum body and press the Vacuum Head Release Button to remove the vacuum head. Then, attach the nozzle attachment to the end of the stick. **[Figure 1.6]**

Note: You can also attach the vacuum body directly to the vacuum head. **[Figure 1.7]**

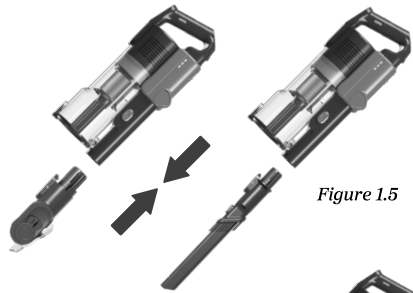

Figure 1.5

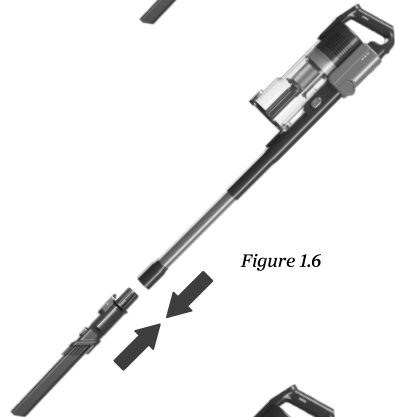

Figure 1.6

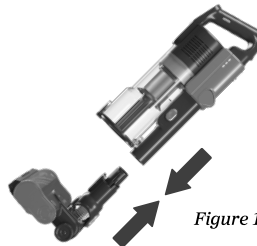

Figure 1.7

Care & Maintenance

BATTERY REMOVAL & INSTALLATION

1. Turn the vacuum off. Press the Battery Release Button and remove the battery.
2. To reinstall, slide the battery into the slot in the vacuum body. **[Figure 2.1]** There will be a clicking sound when the battery is properly installed.

Note:

- To maintain the life of the battery, store the vacuum in a cool, dry place.
- Store the battery in a semi-charged state (at least 2 battery indicator lights) and maintain this by charging the battery every 3 months.



Figure 2.1

CHARGING THE VACUUM

Your vacuum uses a 2,500mAh Li-ion battery. Use the included charger to charge the vacuum.

Note:

- Make sure the vacuum is turned off before charging.
- Charge after every use.

1. Install the charging dock by screwing it into the wall near a power outlet. **[Figure 2.2]**

Note:

- The charging dock must be high enough on the wall to allow the vacuum to hang freely.
- Make sure that the wall is free of gas pipes, water pipes, electrical cables, and wires.
- **Do not** use glue or other adhesives to install the charging dock.

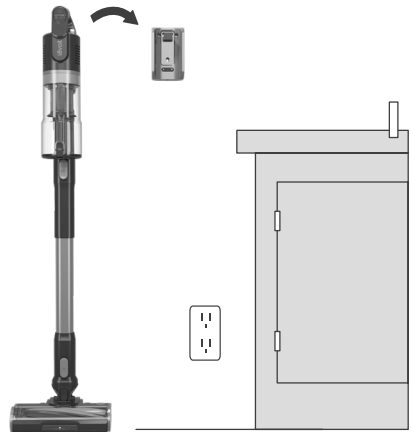

Figure 2.2

Care & Maintenance (cont.)

2. Hang the vacuum on the charging dock.
3. Insert the charger into the charging port on the charging dock.

[Figure 2.3]

4. Plug the charger into the outlet. The battery lights will blink while charging. [Figure 2.3]

Note: Charging time is 3–4 hours.

5. When the vacuum is fully charged, the 3 battery indicator lights will turn solid for 5 minutes, then turn off.



Figure 2.3

Alternatively, the battery can be charged separately from the vacuum body.

1. Press the Battery Release Button to remove the battery.
2. Insert the charger into the charging port on the battery. [Figure 2.4]
3. Plug the charger into an outlet. The battery indicator lights will blink while charging.

Note: Charging time is 3–4 hours.

4. When the battery is fully charged, the 3 battery indicator lights will turn solid for 5 minutes, then turn off.

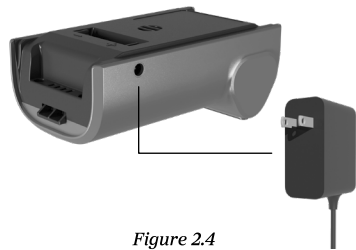





Figure 2.4

Battery Indicator Light Chart (While Charging)

Battery Level	Battery Indicators
0–35%	
35–70%	
70–100%	
100%	

*The 3 battery indicator lights will turn solid for 5 minutes, then turn off.

WARNING:

- **Only** charge the battery with the charger specified by Levoit.
- If you are not using the battery for an extended period, store it in a cool, dry place.
- Store the battery in a semi-charged state (at least 2 battery indicator lights) and maintain this by charging the battery every 3 months.

EMPTYING THE DUST BIN

When dust in the dust bin reaches the MAX line, empty the container.

Important: **Do not** overfill the dust bin. If the dust bin is too full, it may affect the performance of the vacuum.

1. Turn the vacuum off. Remove the dust bin by pressing the Dust Bin Release Button.
2. Hold the dust bin over a trash can and press the Lid Release Button. **[Figure 2.5]** Use caution, as the lid will open when the release button is pushed.

Note: Holding the dust bin inside a trash can prevents dust from spilling out.

3. Empty out debris and dirt, then close the lid.

Alternatively, you can remove the vacuum body to empty the dust bin.

1. Remove the vacuum body by pressing the Vacuum Body Release Button.
2. Hold the dust bin over a trash can and press the Lid Release Button. **[Figure 2.5]**

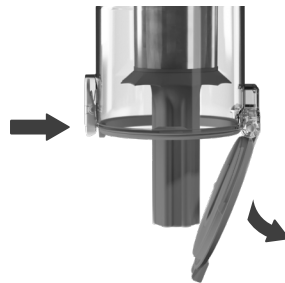

Figure 2.5

Cleaning

CLEANING THE VACUUM BODY

1. Turn the vacuum off.
2. Wipe the outside of the vacuum down with a damp cloth.
3. Allow the vacuum to completely dry before using.

Note: Do not allow water to enter the internal parts or motor of the vacuum.

CLEANING THE DUST BIN & METAL FILTER

1. Make sure the vacuum is off and the dust bin is completely empty before cleaning (see **Emptying the Dust Bin**, page 11).
2. Press the Dust Bin Release Button and pull the dust bin to remove it. *[Figure 3.1]* Empty out any remaining dust and debris, and remove any hair tangled around the metal filter.
3. Remove the felt filter and foam filter from the top of the dust bin. Set aside or wash the filters (see **Cleaning the Felt, Foam, & HEPA Filters**, page 13).
4. Rotate the metal filter counterclockwise to remove it. *[Figure 3.2]*
5. Rinse the dust bin and metal filter with water and allow them to dry. Make sure the parts are completely dry before using.
6. Reattach the metal filter and replace the foam filter and felt filter. Attach the dust bin to the vacuum body.



Figure 3.1



Figure 3.2

CLEANING THE FELT, FOAM, & HEPA FILTERS

To maintain the performance of your filters, they should be routinely washed and replaced.

- If you notice decreased suction power, or the filter is visibly dirty, clean the filter immediately.
- The felt filter and foam filter should be **washed at least once a month and replaced every 3 months.**
- The HEPA filter should be **washed at least once a year.**
- **Do not** put filters in a dishwasher, washing machine, tumble dryer, oven, or microwave, or place near an open flame.
- **Never** operate the vacuum without the dust bin or filters properly installed.
- Frequent use may require cleaning the filters more often. Cleaning the filters regularly helps maintain your vacuum's cleaning performance.
- You may need to replace the filters more frequently depending on your use and environment.
- If the surrounding humidity is high, please **allow** the filters to air-dry for a longer period of time before reinstalling them back into the vacuum.

Replacement Filters:

- To maintain the performance of your vacuum, **only** use official Levoit filters. For more information, contact **Customer Support** (see page 19).

FELT & FOAM FILTERS

1. Press the Dust Bin Release Button to remove the dust bin. **[Figure 3.3]**
2. Remove the felt filter and the foam filter. **[Figure 3.4]**
3. Clean the felt and foam filters with water. Allow the filters to air-dry completely under the sun or in a dry, ventilated place before reinstallation.
4. Replace the foam filter, followed by the felt filter.

Note: Make sure the felt filter has the ribbon-handle side facing outward when you insert the filter.

5. Place the dust bin back onto the vacuum body.



Figure 3.3



Figure 3.4

Cleaning (cont.)

HEPA FILTER

1. Press the Dust Bin Release Button to remove the dust bin. **[Figure 3.5]**
2. Pull out the HEPA filter from the vacuum body. **[Figure 3.6]**
3. If necessary, clean the HEPA filter with water. Allow the filter to air-dry completely under the sun or in a dry, ventilated place before reinstallation. **[Figure 3.7]**
4. Push the HEPA filter back in the vacuum body until you hear a click, then replace the dust bin.



Figure 3.5



Figure 3.6



Figure 3.7

CLEANING THE ROLLER BRUSH

Periodically check the roller brush for hair or debris. The roller brush will automatically shut off if it is blocked or jammed.

1. Turn the vacuum off. Detach the vacuum head from the stick by pressing the Vacuum Head Release Button.
2. Press the Roller Brush Release Button, slide the side panel up to open, then pull out the roller brush. **[Figure 3.8]**
3. If the roller brush is jammed, carefully use a pair of scissors or a sharp knife to remove any hair or debris tangled around the roller brush.
4. Insert the roller brush back into the vacuum head. Slide the side panel down to lock it in place.

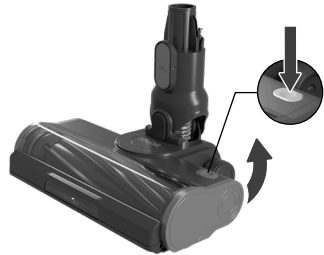

Figure 3.8

Storage

When the vacuum is not in use, store it on the charging dock:

1. Screw the charging dock into the wall near a power outlet (see **Charging the Vacuum**, page 9).
2. Hang the vacuum on the charging dock.



Note:

- **Always** store the vacuum on the charging dock.
- *If necessary, the vacuum can be stored in a closet.*
- *If storing for long periods of time, periodically charge the battery to preserve the life of the battery.*

Disposing of the Battery

- The battery contains materials that are harmful to the environment and must be removed from the vacuum before it is discarded.
- When removing the battery, the vacuum must be turned off.
- Discarded batteries should be handled properly. **Do not** put batteries into fire, water, or soil.
- If battery leakage touches skin or clothing, flush with water immediately to avoid skin injury and seek medical help.

Troubleshooting

Problem	Possible Solution
Vacuum will not turn on.	The battery is not installed correctly (see Battery Removal & Installation , page 9).
	Recharge the vacuum (see Charging the Vacuum , page 9).
	The vacuum motor overheated. Allow the vacuum to cool for 1 hour before turning it back on.
Vacuum is not charging.	The charger is not properly plugged in or you are using the wrong charger. Use the provided Levoit charger only (see Charging the Vacuum , page 9).
 flashes.	Empty the dust bin and check for blockage inside the vacuum head and stick. Remove any blockages and clean the filters (see Cleaning , page 12).
Roller brush not turning ( flashes).	Clean the roller brush and remove any debris blocking the brush (see Cleaning the Roller Brush , page 14).
Vacuum makes an abnormal noise.	Clean the roller brush and remove any debris blocking the brush (see Cleaning the Roller Brush , page 14).
	Check for blockage inside the vacuum body, vacuum head, and stick. Remove any blockage (see Cleaning , page 12).
Vacuum has low suction power.	Battery may be low. Recharge the battery to full charge (see Charging the Vacuum , page 9).
	Clean the roller brush and remove any debris blocking the brush (see Cleaning the Roller Brush , page 14).
	The dust bin and filters may be full. Empty the dust bin and clean the filters (see Cleaning , page 12).
	Check for blockage inside the vacuum body, vacuum head, and stick. Remove any blockage (see Cleaning , page 12).
Vacuum releases a bad or unusual smell.	The environment's relative humidity may be high or the vacuum may have absorbed water and caused the filter to grow mold. Replace the filters (contact Customer Support , page 19).
	The filters may be dirty. Clean the filter (see Cleaning , page 12).
	The dust bin may be dirty. Empty and clean the dust bin (see Cleaning , page 12).

Problem	Possible Solution
Display shows E0.	Make sure you are using the original charger. Use the provided Levoit charger only (see Charging the Vacuum , page 9).
	Check for foreign objects or liquid in the charging port.
Display shows E1.	Make sure the battery is installed correctly (see Battery Removal & Installation , page 9).
	The battery may be overheating. Remove the battery and allow it to cool for 1 hour before reinstalling.
	Check for foreign objects or liquid in the charging port.
Display shows E2.	Contact Customer Support (see page 19).
Display shows E3.	Make sure the vacuum head is properly installed (see Using Your Vacuum , page 7).
	Make sure the roller brush is properly installed.

If your problem is not listed, please contact **Customer Support** (see page 19).

Federal Communication Commission Interference Statement – Part 15

This device complies with Part 15 of the FCC Rules. Operation is subject to the following two conditions:

1. This device may not cause harmful interference, and
2. This device must accept any interference received, including interference that may cause undesired operation.

NOTE: This equipment has been tested and found to comply with the limits for a Class B digital device, pursuant to Part 15 of the FCC Rules. These limits are designed to provide reasonable protection against harmful interference in a residential installation. This equipment generates, uses and can radiate radio frequency energy and, if not installed and used in accordance with the instructions, may cause harmful interference to radio communications. However, there is no guarantee that interference will not occur in a particular installation. If this equipment does cause harmful interference to radio or television reception, which can be determined by turning the equipment off and on, the user is encouraged to try to correct the interference by one or more of the following measures:

- Reorient or relocate the receiving antenna.
- Increase the separation between the equipment and receiver.
- Connect the equipment into an outlet on a circuit different from that to which the receiver is connected.
- Consult the dealer or an experienced radio/TV technician for help.

FCC Caution: Any changes or modifications not expressly approved by the party responsible for compliance could void the user's authority to operate this equipment.

FCC SDOC Supplier's Declaration of Conformity

Vesync (US) Corporation hereby declares that this equipment is in compliance with FCC requirements. The declaration of conformity can be found at: <https://www.vesync.com/legal/compliance/fcc>

Warranty Information

Product Name	Levoit VortexIQ Pro Cordless Stick Vacuum
Model	LSV-V222-DUSR
<i>For your own reference, we strongly recommend that you record your order ID and date of purchase.</i>	
Order ID	
Date of Purchase	

Levoit Limited Product Warranty

Register your products at <https://warranty.levoit.com/warranty> to stay up to date with important product information such as product updates, limited warranties, usage and maintenance recommendations, and notifications concerning safety warnings or product recalls. Registration is not required to claim your limited warranty.

Two (2) Year Limited Consumer Product Warranty

Vesync (US) Corporation ("Vesync") warrants that the product shall be free from defects in material and workmanship for a period of 2 years from the date of original purchase ("Limited Warranty Period"), provided the product was used in accordance with its use and care instructions (e.g., in the intended environment and under normal circumstances).

Your Limited Warranty Benefits

During the Limited Warranty Period and subject to this limited Warranty Policy, Vesync will, in its sole and exclusive discretion, either (i) refund the purchase price if the purchase was made directly from the online Levoit store, (ii) repair any defects in material or workmanship, (iii) replace the product with another product of equal or greater value, or (iv) provide store credit in the amount of the purchase price.

Who is Covered?

This limited warranty extends only to the original consumer purchaser of the product and is not transferable to any subsequent owner of the product, regardless of whether the product transferred ownership during the specified term of the limited warranty. The original consumer purchaser must provide verification of the defect or malfunction and proof of the date of purchase to claim the Limited Warranty Benefits.

Be Aware of Unauthorized Dealers or Sellers

This limited warranty does not extend to products purchased from unauthorized dealers or sellers. Vesync's limited warranty only extends to products purchased from authorized dealers or sellers that are subject to Vesync's quality controls and have agreed to follow its quality controls. Please be

aware, products purchased from an unauthorized website or dealer may be counterfeit, used, defective, or may not be designed for use in your country. You can protect yourself and your products by making sure you only purchase from Vesync or its authorized dealers.

If you have any questions about a specific seller, or if you think you may have purchased your product from an unauthorized seller, please contact our Customer Support Team via support.levoit.com.

What's Not Covered?

- Normal wear and tear, including normal wearing parts, such as dust bin, filter, roller brush, battery, and power cord, or carpet or floor damage due to misuse.
- If the model number, serial number or production date code on the product has been altered, removed or made illegible.
- If the product has been modified from its original condition.
- If the product has not been used in accordance with directions and instructions in the user manual.
- Damages caused by connecting peripherals, additional equipment or accessories other than those recommended in the user manual.
- Damages or defects caused by accident, abuse, misuse, or improper or inadequate maintenance.
- Damages or defects caused by service or repair of the product performed by an unauthorized service provider or by anyone other than Vesync.
- Damages or defects occurring during commercial use, rental use, or any use for which the product is not intended.
- If the unit has been damaged, including but not limited to damage by animals, lightning, abnormal voltage, fire, natural disaster, transportation, dishwasher, or water (unless the user manual expressly states that the product is dishwasher-safe).
- Incidental and consequential damages.
- Damages or defects exceeding the cost of the product.

Claiming Your Limited Warranty Service in 5 Simple Steps:

1. Make sure your product is within the specified limited warranty period.
2. Make sure you have a copy of the invoice and order ID or proof-of-purchase.
3. Make sure you have your product. DO NOT dispose of your product before contacting us.
4. Contact our Customer Support Team via support.levoit.com.
5. Once our Customer Support Team has approved your request, please return the product with a copy of the invoice and order ID.

Sole and Exclusive Remedy

THE FOREGOING LIMITED WARRANTY CONSTITUTES VESYNC'S EXCLUSIVE LIABILITY, AND YOUR SOLE AND EXCLUSIVE REMEDY, FOR ANY BREACH OF ANY WARRANTY OR OTHER NONCONFORMITY OF THE PRODUCT COVERED BY THIS LIMITED PRODUCT WARRANTY STATEMENT. THIS LIMITED WARRANTY IS EXCLUSIVE, AND IN LIEU OF ALL OTHER WARRANTIES. NO EMPLOYEE OF VESYNC OR ANY OTHER PARTY IS AUTHORIZED TO MAKE ANY WARRANTY IN ADDITION TO THE LIMITED WARRANTY IN THIS LIMITED PRODUCT WARRANTY STATEMENT.

Disclaimer of Limited Warranties

TO THE FULLEST EXTENT PROVIDED BY APPLICABLE LAW, EXCEPT AS WARRANTED IN THIS LIMITED PRODUCT WARRANTY POLICY, VESYNC PROVIDES THE PRODUCTS YOU PURCHASE FROM VESYNC "AS IS" AND VESYNC HEREBY DISCLAIMS ALL WARRANTIES OF ANY KIND, WHETHER EXPRESS OR IMPLIED, STATUTORY, OR OTHERWISE, INCLUDING BUT NOT LIMITED TO ANY WARRANTIES OF MERCHANTABILITY, NON-INFRINGEMENT, AND FITNESS FOR PARTICULAR PURPOSE.

Limitations of Liability

TO THE FULLEST EXTENT PROVIDED BY APPLICABLE LAW, IN NO EVENT WILL VESYNC, ITS AFFILIATES, OR THEIR LICENSORS, SERVICE PROVIDERS, EMPLOYEES, AGENTS, OFFICERS, OR DIRECTORS BE LIABLE FOR:

(a) DAMAGES OF ANY KIND ARISING OUT OF OR IN CONNECTION WITH PRODUCTS PURCHASED FROM VESYNC IN EXCESS OF THE PURCHASE PRICE PAID BY THE PURCHASER FOR SUCH PRODUCTS, OR

(b) INDIRECT, SPECIAL, INCIDENTAL, CONSEQUENTIAL, OR PUNITIVE DAMAGES EVEN IF VESYNC OR ONE OF ITS SUPPLIERS HAS BEEN ADVISED OF THE POSSIBILITY OR LIKELIHOOD OF SUCH DAMAGES.

AND REGARDLESS OF WHETHER CAUSED BY TORT (INCLUDING NEGLIGENCE), BREACH OF CONTRACT, OR OTHERWISE. OUR LIABILITY SHALL UNDER NO CIRCUMSTANCES EXCEED THE ACTUAL AMOUNT PAID BY YOU FOR THE DEFECTIVE PRODUCT, NOR SHALL WE UNDER ANY CIRCUMSTANCES BE LIABLE FOR ANY CONSEQUENTIAL, INCIDENTAL, SPECIAL OR PUNITIVE DAMAGES OR LOSSES, WHETHER DIRECT OR INDIRECT.

EXCEPT AS COVERED BY THIS LIMITED PRODUCT WARRANTY STATEMENT, VESYNC SHALL NOT BE LIABLE FOR COSTS ASSOCIATED WITH THE REPLACEMENT OR REPAIR OF PRODUCTS PURCHASED FROM IT, INCLUDING, BUT NOT LIMITED TO, LABOR, INSTALLATION, OR OTHER COSTS INCURRED BY THE USER AND, IN

PARTICULAR, ANY COSTS RELATING TO THE REMOVAL OR REPLACEMENT OF ANY PRODUCT.

OTHER RIGHTS YOU MAY HAVE

SOME JURISDICTIONS DO NOT ALLOW FOR: (1) EXCLUSION OF IMPLIED WARRANTIES; (2) LIMITATION ON THE DURATION OF IMPLIED WARRANTIES; AND/OR (3) EXCLUSION OR LIMITATION OF INCIDENTAL OR CONSEQUENTIAL DAMAGES; SO THE DISCLAIMERS IN THIS POLICY MAY NOT APPLY TO YOU. IN THESE JURISDICTIONS YOU HAVE ONLY THE IMPLIED WARRANTIES THAT ARE EXPRESSLY REQUIRED TO BE PROVIDED IN ACCORDANCE WITH APPLICABLE LAW. THE LIMITATIONS OF WARRANTIES, LIABILITY, AND REMEDIES APPLY TO THE MAXIMUM EXTENT PERMITTED BY LAW. ALTHOUGH THIS LIMITED WARRANTY GIVES YOU SPECIFIC LEGAL RIGHTS, YOU MAY HAVE OTHER RIGHTS IN YOUR JURISDICTION. THIS STATEMENT OF LIMITED WARRANTY IS SUBJECT TO APPLICABLE LAWS THAT APPLY TO YOU AND THE PRODUCT. PLEASE REVIEW THE LAWS IN YOUR JURISDICTION TO UNDERSTAND YOUR RIGHTS FULLY.

CHANGES TO THIS POLICY

We may change the terms and availability of this limited warranty at our discretion, but any changes will not be retroactive.

This warranty is made by:

Vesync (US) Corporation

1775 Flight Way, Suite 150, Tustin, CA 92782, USA

Customer Support

If you have any questions or concerns about your new product, please contact our Customer Support Team.

Vesync (US) Corporation

1775 Flight Way, Suite 150
Tustin, CA 92782, USA

URL: support.levoit.com

Toll-Free: 1-888-726-8520

SUPPORT HOURS

Mon–Fri, 9:00 am–5:00 pm PST/PDT

**Please have your order invoice and order ID ready before contacting Customer Support.*

lěvoit

by VeSync



A1_26B10_ml_PR_us