

Operator's Manual

CRAFTSMAN[®]

12 in. COMPOUND MITER SAW

WITH LASER TRAC[®]

Model No. 137.212170

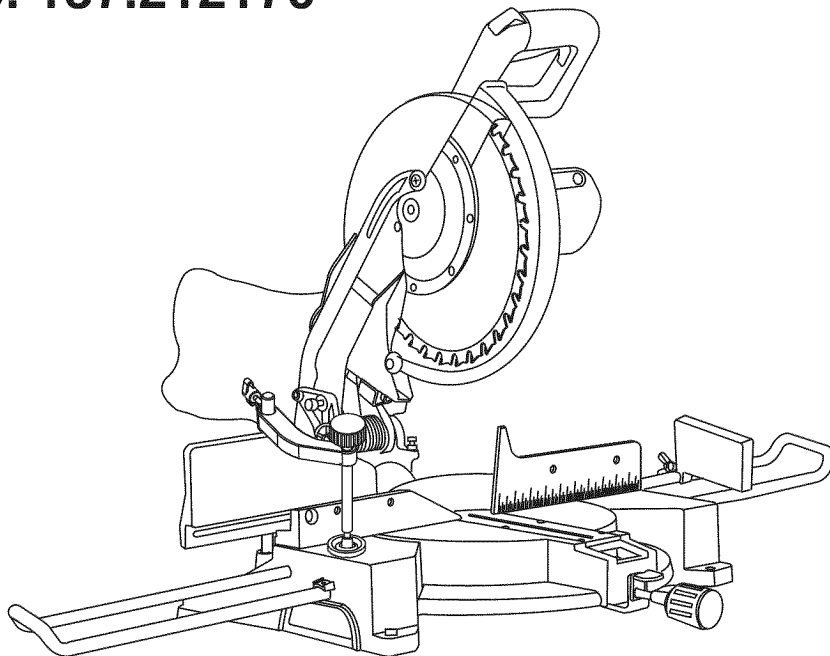

CAUTION:

Before using this Miter Saw, read this manual and follow all its Safety Rules and Operating Instructions

- Safety Instructions
- Installation
- Operation
- Maintenance
- Parts List

**Customer Help Line
For Technical Support
1-800-843-1682**

**Sears Parts &
Repair Center
1-800-488-1222**

Sears, Roebuck and Co., Hoffman Estates, IL 60179 USA

Visit our Craftsman website: www.sears.com/craftsman

Part No. 137212170001

Printed in China

TABLE OF CONTENTS

SECTION	PAGE	SECTION	PAGE
Warranty	2	Know Your Compound Miter Saw	9
Product Specifications	2	Glossary of Terms	10
Power Tool Safety	4	Assembly and Adjustments	11
Compound Miter Saw Safety	5	Operation	17
Electrical Requirements and Safety	5	Maintenance	23
Accessories and Attachments	7	Troubleshooting Guide	24
Tools Needed for Assembly	7	Parts List	25
Carton Contents	8		

WARRANTY

CRAFTSMAN ONE YEAR FULL WARRANTY

If this Craftsman tool fails due to a defect in material or workmanship within one year from the date of purchase, call 1-800-4-MY-HOME® to arrange for free repair (or replacement if repair proves impossible).

This warranty applies for only 90 days from the date of purchase if this product is ever used for commercial or rental purposes.

This warranty does not include expendable parts, such as lamps, batteries, bits or blades.

This warranty gives you specific legal rights, and you may also have other rights which vary from state to state.

Sears, Roebuck and Co., Hoffman Estates, IL 60179

WARNING

Some dust created by using power tools contains chemicals known to the state of California to cause cancer and birth defects or other reproductive harm. Some examples of these chemicals are:

- Lead from lead-based paints
- Crystalline silica from bricks, cement and other masonry products
- Arsenic and chromium from chemically treated lumber

Your risk from these exposures varies, depending on how often you do this type of work. To reduce your exposure to these chemicals, work in a well ventilated area and work with approved safety equipment such as dust masks that are specially designed to filter out microscopic particles.

PRODUCT SPECIFICATIONS

MOTOR

Power Source	120V AC, 60Hz, 15 Amp
Arbor Shaft Size	5/8 in. (with 1 in. adaptor)
Speed	4200 RPM (No load)
Brake	Electric
Double Insulated	Yes

MITER SAW

Rotating Table:

Miter Detent Stops	0°, 15°, 22.5°, 31.6°, 45° R & L
Bevel Positive Stops	0°, 33.9°, 45° L

Cutting Capacity:

Crosscut	2-1/2 in. x 7-5/8 in. 4 in. x 4 in.
Miter 45° R & L	2-1/2 in. x 5-1/2 in.
Bevel 45° L	1-3/4 in. x 7-5/8 in.
45° Miter and 45° Bevel	1-3/4 in. x 5-1/2 in.
Extension Wings	2

WARNING

To avoid electrical hazards, fire hazards or damage to the tool, use proper circuit protection.

This tool is wired at the factory for 110-120 Volt operation. It must be connected to a 110-120 Volt / 15 Ampere time delay fuse or circuit breaker. To avoid shock or fire, replace power cord immediately if it is worn, cut or damaged in any way.

Before using your tool, it is critical that you read and understand these safety rules. Failure to follow these rules could result in serious injury to you or damage to the tool.

SYMBOLS

WARNING ICONS

Your power tool and its Owner's Manual may contain "WARNING ICONS" (a picture symbol intended to alert you to, and/or instruct you how to avoid, a potentially hazardous condition). Understanding and heeding these symbols will help you operate your tool better and safer. Shown below are some of the symbols you may see.



SAFETY ALERT: Precautions that involve your safety.



PROHIBITION



WEAR EYE PROTECTION: Always wear safety goggles or safety glasses with side shields.



READ AND UNDERSTAND INSTRUCTION MANUAL: To reduce the risk of injury, user and all bystanders must read and understand instruction manual before using this product.



KEEP HANDS AWAY FROM BLADE: Failure to keep your hands away from the blade will result in serious personal injury.



SUPPORT AND CLAMP WORK



DANGER: indicates an imminently hazardous situation which, if not avoided, will result in death or serious injury.



WARNING: indicates a potentially hazardous situation which, if not avoided, could result in death or serious injury.



CAUTION: indicates a potentially hazardous situation which, if not avoided, may result in minor or moderate injury.



CAUTION: used without the safety alert symbol indicates a potentially hazardous situation which, if not avoided, may result in property damage.



POWER TOOL SAFETY

GENERAL SAFETY INSTRUCTIONS BEFORE USING THIS POWER TOOL

Safety is a combination of common sense, staying alert and knowing how to use your power tool.

WARNING

To avoid mistakes that could cause serious injury, do not plug the tool in until you have read and understood the following.

-  **READ** and become familiar with the entire Operator's Manual. **LEARN** the tool's application, limitations and possible hazards.
- KEEP GUARDS IN PLACE** and in working order.
- REMOVE ADJUSTING KEYS AND WRENCHES.** Form the habit of checking to see that keys and adjusting wrenches are removed from the tool before turning ON.
- KEEP WORK AREA CLEAN.** Cluttered areas and benches invite accidents.
- DO NOT USE IN DANGEROUS ENVIRONMENTS.** Do not use power tools in damp locations, or expose them to rain or snow. Keep work area well lit.
- KEEP CHILDREN AWAY.** All visitors and bystanders should be kept a safe distance from work area.
- MAKE WORKSHOP CHILD PROOF** with padlocks, master switches or by removing starter keys.
- DO NOT FORCE THE TOOL.** It will do the job better and safer at the rate for which it was designed.
- USE THE RIGHT TOOL.** Do not force the tool or an attachment to do a job for which it was not designed.
- USE PROPER EXTENSION CORDS.** Make sure your extension cord is in good condition. When using an extension cord, be sure to use one heavy enough to carry the current your product will draw. An undersized cord will result in a drop in line voltage and in loss of power which will cause the tool to overheat. The table on page 5 shows the correct size to use depending on cord length and nameplate ampere rating. If in doubt, use the next heavier gauge. The smaller the gauge number, the heavier the cord.
- WEAR PROPER APPAREL.** Do not wear loose clothing, gloves, neckties, rings, bracelets or other jewelry which may get caught in moving parts. Nonslip footwear is recommended. Wear protective hair covering to contain long hair.
-  **ALWAYS WEAR EYE PROTECTION.** Any power tool can throw foreign objects into the eyes and could cause permanent eye damage. **ALWAYS** wear Safety Goggles (not glasses) that comply with ANSI Safety standard Z87.1. Everyday eyeglasses have only impact-resistant lenses. They **ARE NOT** safety glasses. Safety Goggles are available at Sears. **NOTE:** Glasses or goggles not in compliance with ANSI Z87.1 could seriously injure you when they break.
- WEAR A FACE MASK OR DUST MASK.** Sawing operation produces dust.
-  **SECURE WORK.** Use clamps or a vise to hold work when practical. It is safer than using your hand and it frees both hands to operate the tool.
- DISCONNECT TOOLS FROM POWER SOURCE** before servicing, and when changing accessories such as blades, bits and cutters.
- REDUCE THE RISK OF UNINTENTIONAL STARTING.** Make sure switch is in the OFF position before plugging the tool in.
- USE RECOMMENDED ACCESSORIES.** Consult this Operator's Manual for recommended accessories. The use of improper accessories may cause risk of injury to yourself or others.
- NEVER STAND ON THE TOOL.** Serious injury could occur if the tool is tipped or if the cutting tool is unintentionally contacted.
- CHECK FOR DAMAGED PARTS.** Before further use of the tool, a guard or other part that is damaged should be carefully checked to determine that it will operate properly and perform its intended function – check for alignment of moving parts, binding of moving parts, breakage of parts, mounting and any other conditions that may affect its operation. A guard or other part that is damaged should be properly repaired or replaced.
- NEVER LEAVE THE TOOL RUNNING UNATTENDED. TURN THE POWER "OFF".** Do not walk away from a running tool until the blade comes to a complete stop and the tool is unplugged from the power source.
- DO NOT OVERREACH.** Keep proper footing and balance at all times.
- MAINTAIN TOOLS WITH CARE.** Keep tools sharp and clean for best and safest performance. Follow instructions for lubricating and changing accessories.
- WARNING:** Dust generated from certain materials can be hazardous to your health. Always operate saw in well-ventilated area and provide for proper dust removal.

COMPOUND MITER SAW SAFETY

SPECIFIC SAFETY INSTRUCTIONS FOR THIS COMPOUND MITER SAW

1. **DO NOT** operate the miter saw until it is completely assembled and installed according to these instructions.
2. **IF YOU ARE NOT** thoroughly familiar with the operation of miter saws, seek guidance from your supervisor, instructor or other qualified person.
3. **ALWAYS** hold the work firmly against the fence and table. **DO NOT** perform any operation free hand (use clamp wherever possible).
4. **KEEP HANDS** out of the path of the saw blade. If the workpiece you are cutting would cause your hands to be within 8-3/4 in. of the saw blade, the workpiece should be clamped in place before making the cut.
5. **BE SURE** the blade is sharp, runs freely and is free of vibration.
6. **ALLOW** the motor to come up to full speed before starting a cut.
7. **KEEP THE MOTOR AIR SLOTS CLEAN** and free of chips or dust.
8. **ALWAYS MAKE SURE** all handles are tight before cutting, even if the table is positioned in one of the positive stops.
9. **BE SURE** both the blade and the collar are clean and the arbor bolt is tightened securely.
10. **USE** only blade collars specified for your saw.
11. **NEVER** use blades larger in diameter than 12 inches.
12. **NEVER** apply lubricants to the blade when it is running.
13. **ALWAYS** check the blade for cracks or damage before operation. Replace a cracked or damaged blade immediately.
14. **NEVER** use blades recommended for operation at less than 4200 RPM.
15. **ALWAYS** keep the blade guards in place and use at all times.
16. **NEVER** reach around the saw blade.
17. **MAKE SURE** the blade is not contacting the workpiece before the switch is turned ON.
18. **IMPORTANT:** After completing the cut, release the trigger and wait for the blade to stop before returning the saw to the raised position.
19. **MAKE SURE** the blade has come to a complete stop before removing or securing the workpiece, changing the workpiece angle or changing the angle of the blade.
20. **NEVER** cut metals or masonry products with this tool. This miter saw is designed for use on wood and wood-like products.
21. **NEVER** cut small pieces. If the workpiece being cut would cause your hand or fingers to be within 8-3/4 in. of the saw blade the workpiece is too small.
22. **PROVIDE** adequate support to the sides of the saw table for long work pieces.
23. **NEVER** use the miter saw in an area with flammable liquids or gases.
24. **NEVER** use solvents to clean plastic parts. Solvents could possibly dissolve or otherwise damage the material.
25. **SHUT OFF** the power before servicing or adjusting the tool.
26. **DISCONNECT** the saw from the power source and clean the machine when finished using.
27. **MAKE SURE** the work area is clean before leaving the machine.
28. **SHOULD** any part of your miter saw be missing, damaged, or fail in any way, or any electrical component fail to perform properly, lock the switch and remove the plug from the power supply outlet. Replace missing, damaged, or failed parts before resuming operation.

ELECTRICAL REQUIREMENTS

POWER SUPPLY AND MOTOR SPECIFICATIONS

The AC motor used in this saw is a universal, nonreversible type. See "MOTOR" in the "PRODUCT SPECIFICATIONS" section on page 2.

WARNING

To avoid electrical hazards, fire hazards, or damage to the tool, use proper circuit protection. Your saw is wired at the factory for 120 V operation. Connect to a 120 V, 15 A circuit and use a 15 A time delay fuse or circuit breaker. To avoid shock or fire, if power cord is worn or cut, or damaged in any way, have it replaced immediately.

ELECTRICAL REQUIREMENTS AND SAFETY

ELECTRICAL REQUIREMENTS – cont'd

DOUBLE INSULATED

The power tool is double insulated to provide a double thickness of insulation between you and tool's electrical system. All exposed metal parts are isolated from the internal metal motor components with protecting insulation.

Replacement parts – When servicing, use only identical replacement parts.

Polarized plugs – This saw has a plug that looks like the one shown below:

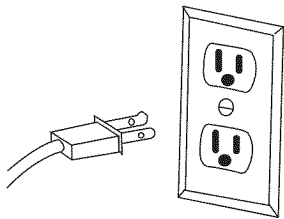

To reduce the risk of electrical shock, this saw has a polarized plug (one blade is wider than the other). This plug will fit in a polarized outlet only one way. If the plug does not fit fully in the outlet, reverse the plug. If it still does not fit, contact a qualified electrician to install the proper outlet. Do not change the plug in any way.

WARNING

Double insulation does not take the place of normal safety precautions when operating this tool.

To avoid electrocution:

1. Use only identical replacement parts when servicing a tool with double insulation. Servicing should be performed by a qualified technician.
2. Do not use power tools in wet or damp locations or expose them to rain or snow.

MOTOR SAFETY PROTECTION IMPORTANT

To avoid motor damage, the motor should be blown out or vacuumed frequently to keep sawdust from interfering with the motor ventilation.

1. **Connect** this saw to a 120 V circuit. This circuit must not be less than a #12 wire with a 20 A time lag fuse or a #14 wire with a 15 A time lag fuse.
NOTE: When using an extension cord on a circuit with a #14 wire, the extension cord must not exceed 25 feet in length.
2. If the motor will not start, release the trigger switch immediately. **UNPLUG THE SAW.** Check the saw blade to make sure it turns freely. If the blade is free, try to start the saw again. If the motor still does not start, refer to the **TROUBLESHOOTING GUIDE.**
3. If the tool suddenly stalls while cutting wood, release the trigger switch, unplug the tool and free the blade from the wood. The saw may now be started and the cut finished.

4. **FUSES** may “blow” or circuit breakers may trip frequently if:
 - a. **MOTOR** is overloaded – overloading can occur if you feed too rapidly or make too many start/stops in a short time.
 - b. **LINE VOLTAGE** is more than 10% above or below the nameplate voltage rating. For heavy loads, the voltage at motor terminals must equal the voltage specified on the nameplate.
 - c. **IMPROPER** or dull saw blades are used.
5. Most motor troubles may be traced to loose or incorrect connections, overload, low voltage or inadequate power supply wiring. Always check the connections, the load and supply circuit if the motor doesn't run well. Check minimum gauge for the length of cord you are using on the chart below.

GUIDELINES FOR EXTENSION CORDS

Use a proper extension cord. Make sure your extension cord is in good condition. When using an extension cord, be sure to use one heavy enough to carry the current your product will draw. An undersized cord will cause a drop in line voltage, resulting in loss of power and overheating. The table below shows the correct size to use depending on cord length and nameplate ampere rating. If in doubt, use the next heavier gauge. The smaller the gauge number, the heavier the cord.

Be sure your extension cord is properly wired and in good condition. Always replace a damaged extension cord or have it repaired by a qualified person before using it. Protect your extension cords from sharp objects, excessive heat and damp or wet areas.

Use a separate electrical circuit for your tools. This circuit must not be less than a #12 wire with a 20 A time lag fuse or a #14 wire with a 15 A time lag fuse.
NOTE: When using an extension cord on a circuit with a #14 wire, the extension cord must not exceed 25 feet in length. Before connecting the tool to the power line, make sure the switch is in the OFF position and the electric current is rated the same as the current stamped on the motor nameplate, running at a lower voltage will damage the motor.

MINIMUM GAUGE FOR EXTENSION CORDS (AWG)

(When using 120 volts only)					
Ampere Rating		Total length of Cord			
More Than	Not More Than	25ft.	50ft.	100ft.	150ft.
0	6	18	16	16	14
6	10	18	16	14	12
10	12	16	16	14	12
12	16	14	12	Not Recommended	

CAUTION: In all cases make certain the receptacle in question is properly grounded. If you are not sure, have a certified electrician check the receptacle.

ACCESSORIES AND ATTACHMENTS

RECOMMENDED ACCESSORIES

⚠ WARNING

- Use only accessories recommended for this miter saw. Follow instructions that accompany accessories. Use of improper accessories may cause hazards.
- The use of any cutting tool except 12 in. saw blades which meet the requirements under recommended accessories is prohibited. Do not use accessories such as shaper cutters or dado sets. Ferrous metal cutting and the use of abrasive wheels is prohibited.
- Do not attempt to modify this tool or create accessories not recommended for use with this tool. Any such alteration or modification is misuse and could result in a hazardous condition leading to possible serious injury.

ACCESSORIES

Visit your Sears Hardware Department or see the Sears Power and Hand Tool Catalog to purchase recommended accessories for this power tool.

⚠ WARNING

To avoid the risk of personal injury, do not modify this power tool or use accessories not recommended by Sears.

⚠ WARNING

Read warnings and conditions on your **CARBIDE TIPPED SAW BLADE**. Do not operate the saw without the proper saw blade guard in place. Carbide is a very hard but brittle material. Care should be taken while mounting, using, and storing carbide tipped blades to prevent accidental damage. Slight shocks, such as striking the tip while handling, can seriously damage the blade. Foreign objects in the workpiece, such as wire or nails, can also cause tips to crack or break off. Before using, always visually examine the blade and tips for bent blade, cracks, breakage, missing or loose tips, or other damage. Do not use if damage is suspected. Failure to heed safety instructions and warnings can result in serious bodily injury.

TOOLS NEEDED FOR ASSEMBLY

Supplied



Blade Wrench

Not supplied



Adjustable Wrench



Hex Key

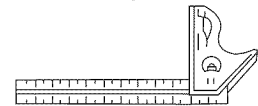

Combination Square

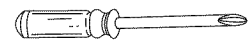

Phillips Screwdriver

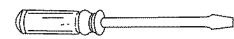

Slotted Screwdriver

COMBINATION SQUARE MUST BE TRUE

Should not gap or overlap when square is flipped over (see dotted figure).

Draw light line on board along this edge.

Straight edge or a 3/4 in. board, this edge must be perfectly straight.

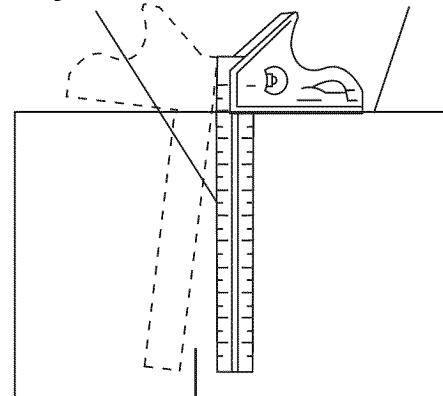

Should not gap or overlap when square flipped over (see dotted figure).

CARTON CONTENTS

UNPACKING YOUR MITER SAW

⚠ WARNING

To avoid injury from unexpected starting or electrical shock, do not plug the power cord into a source of power during unpacking and assembly. This cord must remain unplugged whenever you are working on the saw.

1. Remove the miter saw from the carton.

IMPORTANT: Do not lift miter saw by the trigger switch handle. It may cause misalignment. Lift machine by the built-in carry handle.

2. Place the saw on a secure stationary work surface.
3. Separate all parts from the packing material. Check each one with the illustration to make certain all items are accounted for, before discarding any packing material.

⚠ WARNING

If any part is missing or damaged, do not attempt to assemble the miter saw, or plug in the power cord until the missing or damaged part is correctly replaced. To avoid electric shock, use only identical replacement parts when servicing double insulated tools. Call 1-800-4-MY-HOME® for replacement parts.

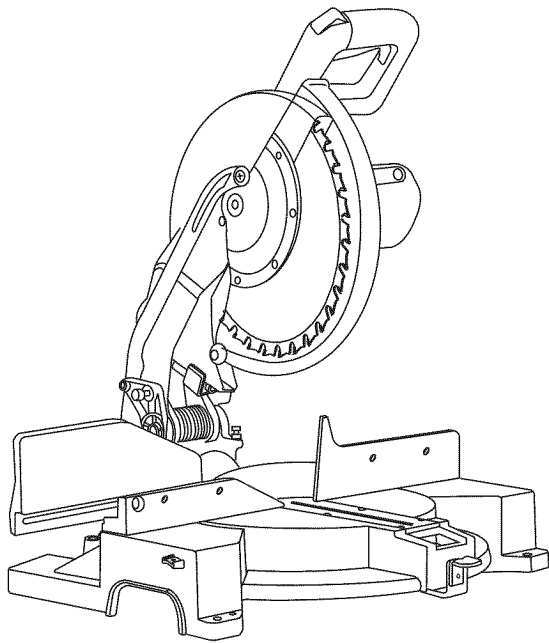

Miter Saw

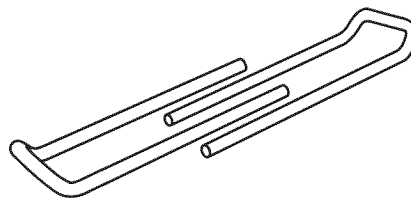

Extension Wings

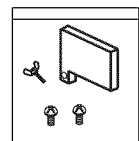

Extension Wing Hardware Bag

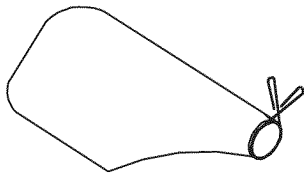

Dust Bag

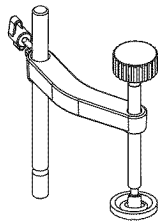

Hold-Down Clamp

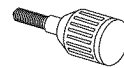

Miter Table Handle

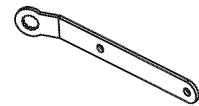

Blade Wrench

KNOW YOUR COMPOUND MITER SAW

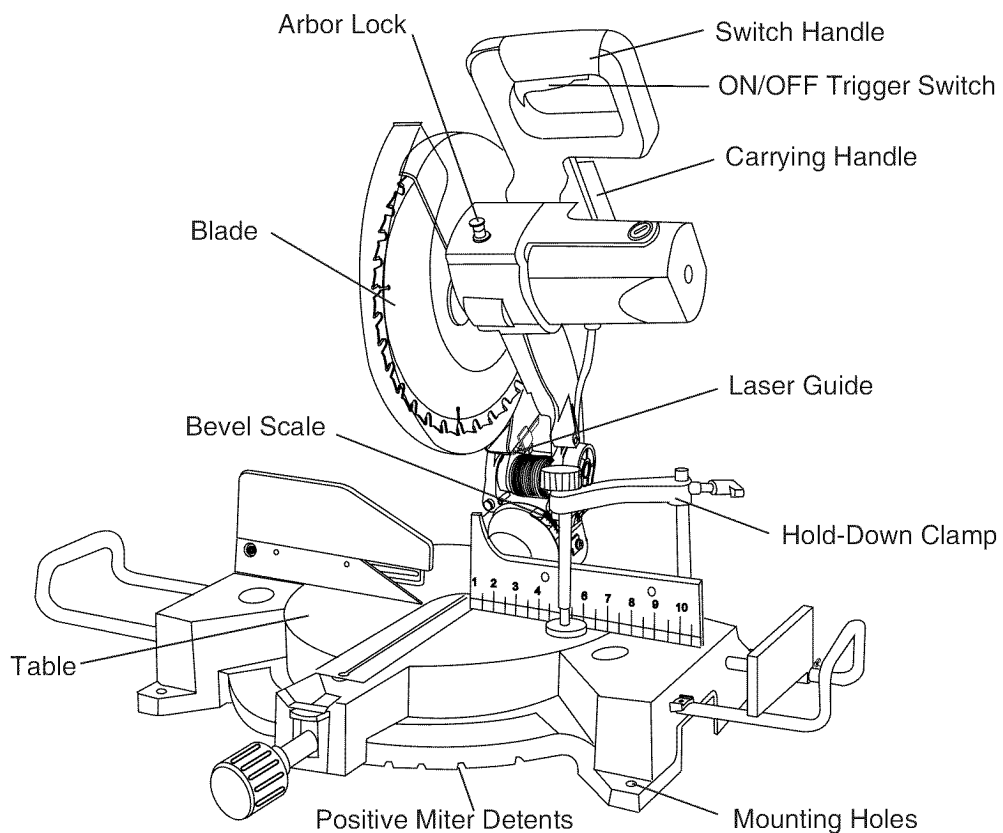
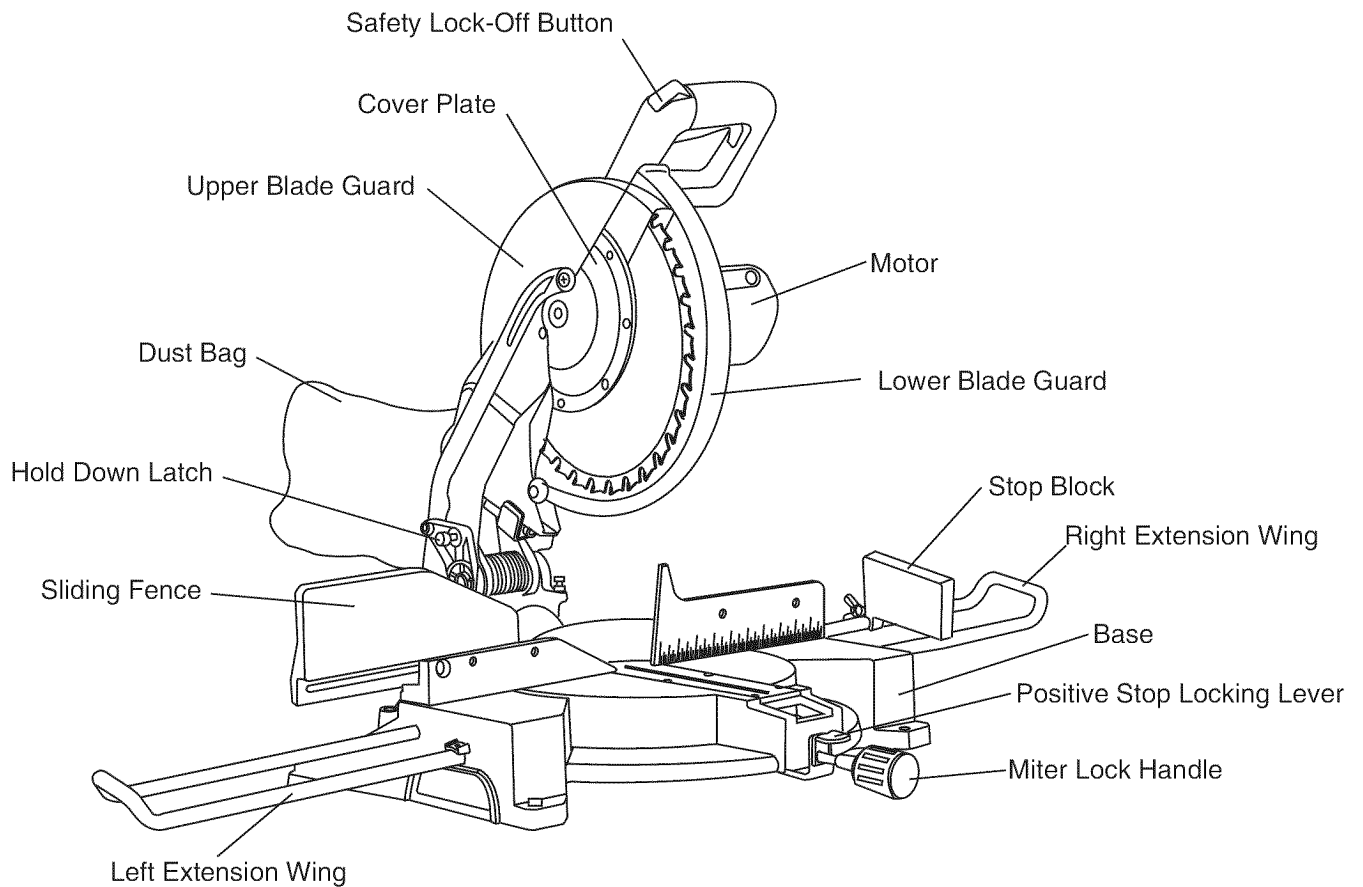

GLOSSARY OF TERMS

COMPOUND MITER SAW TERMS

ARBOR LOCK – Allows the user to keep the blade from rotating while tightening or loosening the arbor bolt during blade replacement or removal.

BASE – Supports the table, holds accessories and allows for workbench or leg set mounting.

BEVEL LOCKING HANDLE – Locks the miter saw at a desired bevel angle.

BEVEL SCALE – To measure the bevel angle of the saw blade 0° to 45° left.

COVER PLATE SCREW – Loosen this screw and rotate the plate for access to the blade arbor bolt.

FENCE – Helps to keep the workpiece from moving when sawing. Scaled to assist with accurate cutting.

LOWER BLADE GUARD – Helps protect your hands from the blade in the raised position, it retracts as the blade is lowered.

MITER HANDLE – Used to rotate the table, and to rotate the saw to a right or left cutting position.

MITER SCALE – Measures the miter angle 0° to 45° left and right.

MOUNTING HOLES – To mount the miter saw to a stable surface.

ON/OFF TRIGGER SWITCH – To start the tool, push the safety lock-off button and squeeze the trigger. Release the trigger to turn off the miter saw.

POSITIVE STOP LOCKING LEVER – Locks the miter saw at a preset positive stop for the desired miter angle.

HOLD DOWN LATCH – Locks the miter saw in the lowered position for compact storage and transportation.

SWITCH HANDLE – The switch handle contains the trigger switch and safety lock-off button. The blade is lowered into the workpiece by pushing down on the handle. The saw will return to its upright position when the handle is released.

WARNING LABELS – Read and understand for your own safety. Make sure all labels are present on machine and legible.

WRENCH STORAGE – Convenient storage to prevent misplacing the blade wrench.

WOODWORKING TERMS

ARBOR – The shaft on which a blade is mounted.

BEVEL CUT – An angle cut made through the face of the workpiece.

COMPOUND CUT – A simultaneous bevel and miter cut.

CROSS CUT – A cut made across the width of the workpiece.

FREEHAND – Performing a cut without using a fence (guide), hold down or other proper device to prevent the workpiece from twisting during the cutting operation.

GUM – A sticky sap from wood products.

HEEL – Misalignment of the blade.

KERF – The amount of material removed by blade cut.

MITER CUT – An angle cut made across the width of the workpiece.

RESIN – A sticky sap that has hardened.

REVOLUTIONS PER MINUTE (RPM) – The number of turns completed by a spinning object in one minute.

SAW BLADE PATH – The area of the workpiece or table top directly in line with the travel of the blade or the part of the workpiece which will be cut.

SET – The distance between two saw blade tips, bent outward in opposite directions to each other. The further apart the tips are, the greater the set.

WORKPIECE – The item being cut. The surfaces of a workpiece are commonly referred to as faces, ends and edges.

ASSEMBLY AND ADJUSTMENTS

ESTIMATED ASSEMBLY TIME: 10~15 MINUTES

INSTALLING THE MITER HANDLE (FIG. A)

1. Thread the miter handle (1) into the hole (2) located at the front of the miter table.

Fig. A

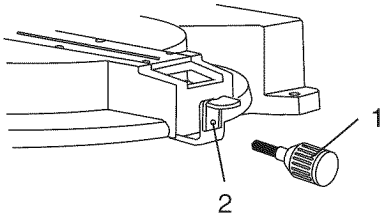

SAW BLADE WRENCH (FIG. B)

1. For convenient storage and prevention of loss, there is a slot (1) in the rear of the switch handle (2) for storing the blade wrench (3) when not in use.

Fig. B

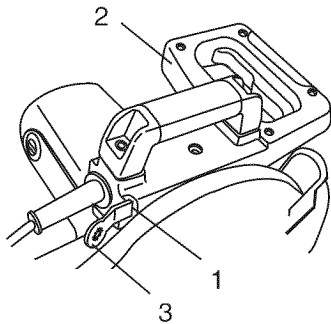

CUTTING HEAD (FIG. C)

Raising

1. Push down slightly on the switch handle (1).
2. Pull out the hold down latch (2).
3. Pull up the cutting head slightly to raise to the up position.

⚠ WARNING

To avoid injury and damage to the saw, transport or store the miter saw with the cutting head locked in the down position. Never use the hold down latch to hold the cutting head in a down position for cutting operations.

Fig. C

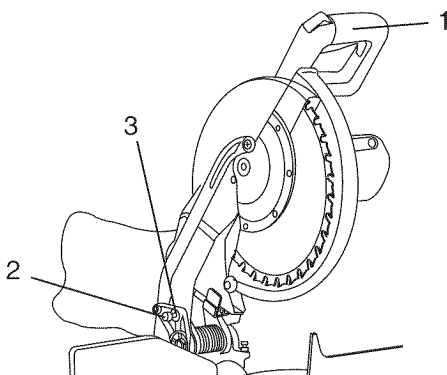

Locking

When transporting or storing the miter saw, the cutting head should always be locked in the down position.

1. Push the cutting head down to its lowest position.

2. Push the hold down latch (2) into the locking hole (3). **IMPORTANT:** To avoid damage, never carry the miter saw by the switch handle, the cutting arm, or the miter table handle.

INSTALLING THE DUST BAG (FIG. D)

1. Squeeze the metal collar wings (2) of the dust bag (1).
2. Place the dust bag neck opening around the exhaust port (3), and release the metal collar wings.

Fig. D

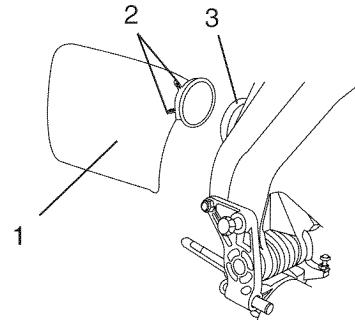

To empty the dust bag, squeeze the metal collar and remove from exhaust port. Open zipper on underside of bag and empty into waste container.

INSTALLING EXTENSION WINGS (FIG. E)

⚠ WARNING

To avoid injury or possible damage to the tool, support long workpieces by installing the extension wings to extend the work support surface.

When using extension and stop block on the right side, hold down clamp must also be in right side. Using hold down clamp on the left side during this operation can cause kick-back and serious injury to the operator.

Installing the stop block (Fig. E)

1. Slide the stop block (1) onto the extension wing (2).
2. Thread the wing bolt (4) into the stop block and tighten.

Installing the extension wings (Fig. E)

1. Place the extension wing into the mounting holes (5) provided in the miter saw base.
2. Thread the extension wing locking screw (6) into the threaded hole (7) and tighten to secure extension in place.
3. Repeat for left side extension wing.

Fig. E

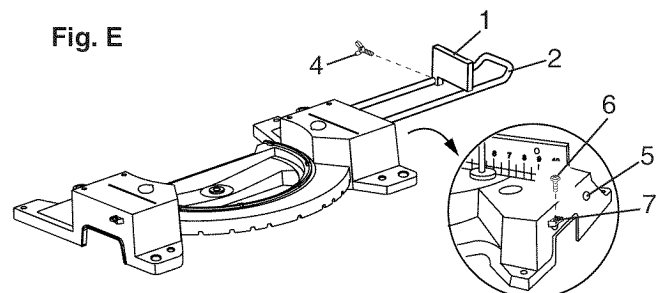

INSTALLING THE HOLD-DOWN CLAMP ASSEMBLY (FIG. F)

1. Loosen the lock knob (1) from the rear side of the saw base (2).
2. Place the hold-down clamp assembly (3) in one of two mounting holes (4).
3. Tighten the lock knob.

Fig. F

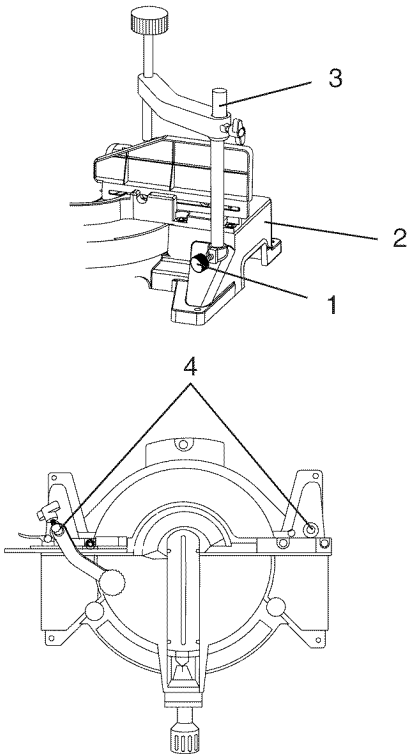

REMOVING OR INSTALLING THE BLADE

Removing Blade (Fig. G, H, I)

WARNING

To avoid injury from an accidental start, make sure the switch is in the OFF position and plug is not connected to the power source outlet.

1. Unplug the saw from the outlet.
2. Allow the miter saw to rise to the upright position. Raise the lower blade guard (1) to the up position. (Fig. G)
3. Loosen the cover plate screw (2) with a Phillips screwdriver.
4. Rotate the cover plate (3) towards the rear of the tool to expose the arbor bolt (4).
5. Place the blade wrench over the arbor bolt.

Fig. G

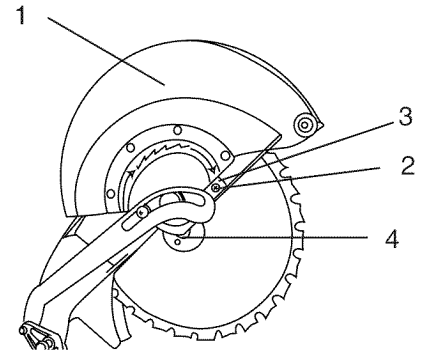

6. Locate the arbor lock (5) on the motor, below the miter saw switch handle. (Fig. H)
7. Press the arbor lock, holding it in firmly while turning the blade wrench clockwise. The arbor lock will engage after turning the wrench. Continue to hold the arbor lock in to keep it engaged, while turning the wrench clockwise to loosen the arbor bolt.

Fig. H

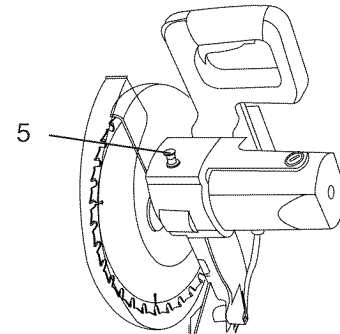

8. Remove the arbor bolt (4), outer blade collar (6), and the blade (7). Do not remove the inner blade collar. (Fig. I)

NOTE: Pay attention to the pieces removed, noting their position and direction they face. Wipe the blade collars clean of any sawdust before installing the new blade.

Fig. I

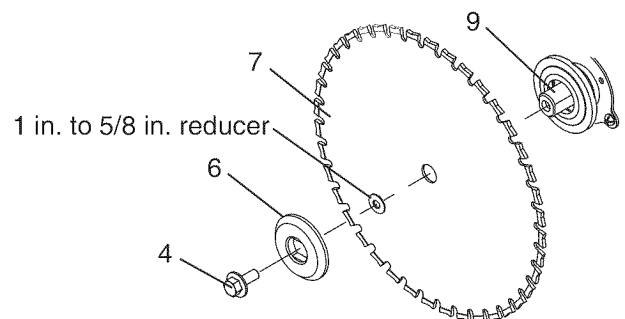

Installing Blade (Fig. G, H, I)

1. Install a 12 in. blade with a 5/8 in. arbor (or a 1 in. arbor with a 5/8 in. reducer as saw comes with) making sure the rotation arrow on the blade matches the clockwise rotation arrow on the upper guard, and the blade teeth are pointing downward.
2. Place the blade collar (6) against the blade and on the arbor (9). Thread the arbor bolt (4) onto the arbor (9) in a counterclockwise direction. (Fig. I)
IMPORTANT: Make sure the flats of the blade collars are engaged with the flats on the arbor shaft. Also, the flat side of the blade collar must be placed against the blade.
3. Place the blade wrench on the arbor bolt.
4. Press the arbor lock (5), holding it in firmly while turning the blade counterclockwise. When arbor lock engages, continue to press it in while tightening the arbor bolt securely. (Fig. H)
5. Rotate the cover plate (3) back to its original position until the slot in the cover plate engages with the cover plate screw (2). While holding the lower blade guard, tighten the screw with a Phillips screwdriver. (Fig. G) **NOTE:** The lower blade guard must be raised to the upright position to access the cover plate screw.
6. Lower the blade guard (1) and verify that the operation of the guard does not bind or stick. (Fig. G)
7. Be sure the arbor lock is released so the blade turns freely.

WARNING

- To avoid injury, never use the saw without the cover plate secure in place. It keeps the arbor bolt from falling out if it accidentally loosens, and helps prevent the spinning blade from coming off the saw.
- Make sure the collars are clean and properly arranged. Lower the blade into the table and check for any contact with the metal base or the turn table.

ADJUSTMENT INSTRUCTIONS

WARNING

To avoid injury from an accidental start, make sure the switch is in the OFF position and the plug is not connected to the power source outlet.

ADJUSTING FENCE SQUARENESS (FIG. J)

1. Lower the cutting arm and lock in position.
2. Using a square, lay the heel of the square against the blade, and the rule against the fence (2) as shown. Check to see if the fence is 90° to the blade.
3. If not, loosen the three fence locking bolts (1), adjust

fence 90° to the blade and tighten the fence locking bolts.

CAUTION: If the saw has not been used recently, recheck blade squareness to the fence and readjust if needed.

Fig. J

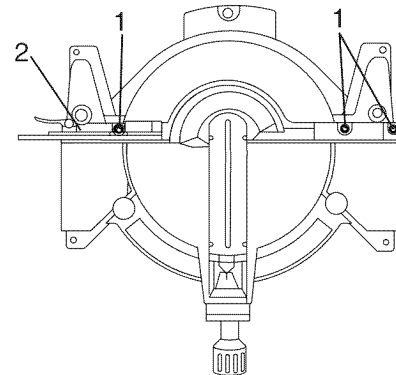

MITER SCALE (FIG. K)

The miter scale assists the user in setting the desired miter angles from 47° left to 47° right. The miter saw table has nine of the most common angle settings with positive stops at 0°, 15°, 22.5°, 31.6° and 45°. These positive stops position the blade at the desired angle quickly and accurately.

To Adjust the Angles:

1. Unlock the miter table by turning the miter handle (1) counterclockwise.
2. While holding the positive-stop locking lever (2) down, grasp the miter handle and rotate the miter table left or right to the desired angle.
3. If the desired angle is one of the nine positive stops, release the positive-stop locking lever, making sure the lever snaps into position, and then secure by tightening the miter handle.
4. If the miter angle desired is not one of the nine positive stops, simply lock the miter table into position by turning the miter handle in the clockwise direction.

To Adjust the Indicator:

1. Position the miter table at zero degrees.
2. Loosen the pointer screw (4) and adjust the indicator to the 0° mark on the miter scale (3) and retighten the screw.

Fig. K

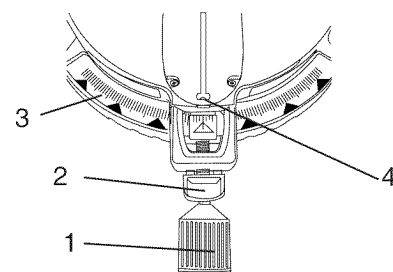

CUTTING HEAD DOWNWARD TRAVEL ADJUSTMENT (FIG. L)

⚠ WARNING

To avoid injury from unexpected starting or electrical shock, turn the switch OFF and remove the power cord from the power source.

NOTE: Before each cutting operation, check the position of the blade to make sure it does not contact any metal surface. If the blade contacts any metal surface, the depth of travel must be adjusted.

1. Lower the blade as far as possible.
2. Loosen the locknut (1).
3. Turn the adjustment bolt (2) out (counterclockwise) to decrease the cutting depth or in (clockwise) to increase the cutting depth.
4. Rotate the blade manually to check for contact to any metal surface.
5. Repeat until adjusted properly, and tighten the locknut to secure the adjustment bolt into position.

Fig. L

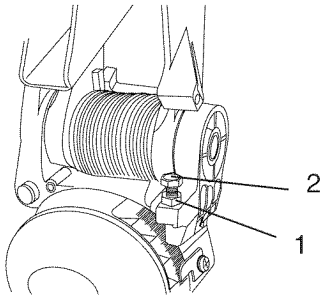

BEVEL STOP ADJUSTMENT (FIG. M, N and O)

⚠ WARNING

To avoid injury from unexpected starting or electrical shock, make sure the trigger is released and remove the power cord from the power source.

90°(0°) Bevel adjustment (Fig. M)

1. Loosen bevel lock handle (1) and tilt the cutting arm completely to the right. Tighten the bevel lock handle. Lower blade.
2. Place a combination square (2) on the miter table with the rule against the table and the heel of the square against the saw blade.
3. If the blade is not 90°(0°) square with the miter table, loosen the bevel lock handle, tilt the cutting head completely to the left, loosen the jamb nut (4) on the bevel angle adjustment bolt (3) and use a 10 mm wrench to adjust the bolt (3) in or out to increase or decrease the bevel angle.
4. Tilt the cutting arm to back to the right at 90°(0°) bevel and recheck for alignment.

5. Repeat steps 1 through 4 if further adjustment is needed.
6. Tighten bevel lock handle (1) and jamb nut (4) when alignment is achieved.

Fig. M

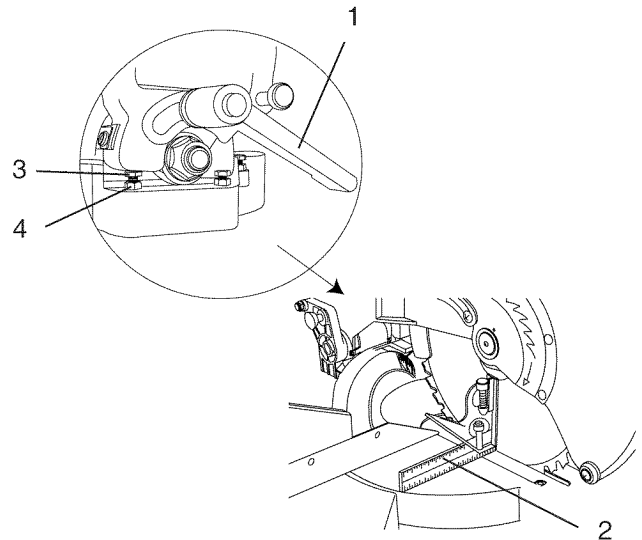

90°(0°) Bevel indicator (Fig. N)

1. When the blade is exactly 90°(0°) to the table, loosen the bevel indicator screw (5) using a #2 Phillips screwdriver.
2. Adjust bevel indicator (6) to the "0" mark (7) on the bevel scale and retighten the screw.

Fig. N

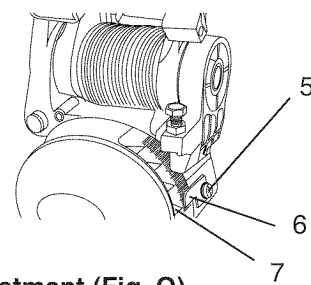

45° Bevel adjustment (Fig. O)

1. Loosen the bevel lock handle (7) and tilt the cutting head completely to the left.
2. Using a combination square, check to see if the blade angle is 45° to the table.
3. If the blade is not at 45° to the miter table, tilt the cutting arm to the right, loosen the jamb nut (8) and turn the bevel angle adjustment bolt (9) in or out with a 10 mm wrench accordingly.
4. Tilt the cutting arm to the left to 45° bevel and recheck for alignment.
5. Repeat steps 1 through 4 until the blade is at 45° to the miter table.
6. Tighten bevel lock handle (7) and jamb nut (8) when alignment is achieved.

Fig. O

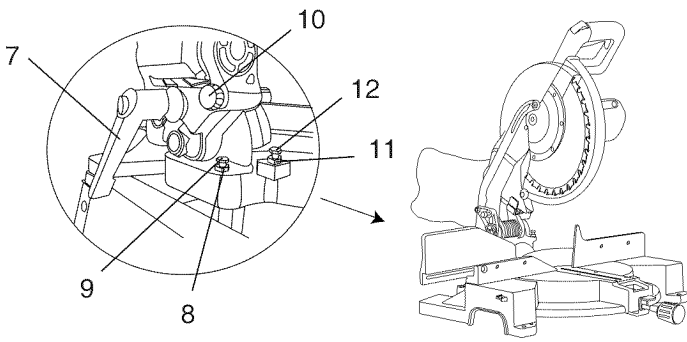

33.9° Bevel Adjustment (Fig. O)

1. Push the bevel detent pin (10) in toward the front of the unit.
2. Unlock the bevel lock handle and tilt the cutting arm to the crown molding positive stop at 33.9°.
3. Using a combination square, check to see if the blade angle is 33.9° to the table.
4. If the blade is not at 33.9° to the miter table, loosen locknut (11) then turn the bevel angle adjusting bolt (12) in or out with a 10 mm wrench until the blade is at 33.9° to the miter table.
5. Secure the locking nut (11) into position after alignment is achieved.

MOUNTING THE MITER SAW (FIG. P)

⚠ WARNING

To avoid injury from unexpected saw movement:

- Before moving the saw, disconnect the power cord from the outlet, and lock the cutting arm in the lower position using the hold down latch.
- **NOTE:** The hold down latch is for carrying or storing the tool. It is not to be used for holding the saw while cutting. Lower blade and press in hold down latch to secure saw for transport or storage.
- Never carry the miter saw by the power cord or by the switch handle. Carrying the tool by the power cord could cause damage to the insulation or wire connections resulting in electric shock or fire.
- To avoid injury from flying debris, do not allow visitors to stand behind the saw.
- Place the saw on a firm, level work-surface where there is room for handling and properly supporting the workpiece.
- Support the saw on a level work surface.
- Bolt or clamp the saw to its support.

Place the saw in the desired location, either on a work bench or recommended leg set. The base of the saw has four mounting holes (1). (Fig. P-1)

Mounting instructions (if stand is not used)

1. **For stationary use**, place the saw in the desired location, directly on a workbench where there is room for handling and proper support of the workpiece. The base of the saw has four mounting holes. Bolt the base of the miter saw (1) to the workbench (5), using the fastening method as shown in Fig P.

Fig. P

1. Miter saw base
2. Hex head bolt
3. Rubber washer
4. Flat washer
5. Workbench
6. Flat washer
7. Lockwasher
8. Hex nut
9. Jam nut

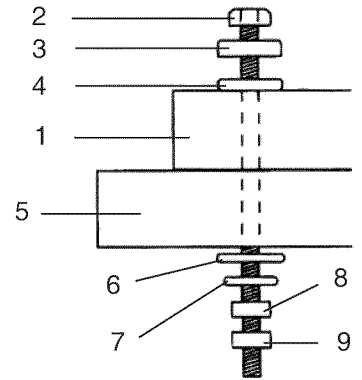
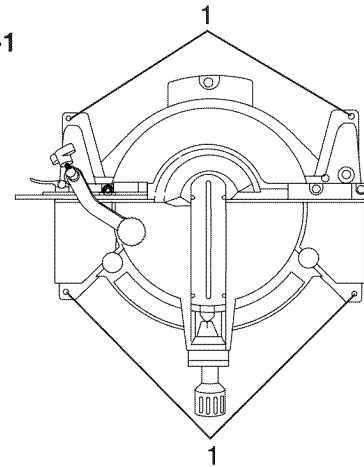

Fig. P-1



NOTE: Mounting hardware is not included with this tool. Bolts, nuts, washers, and screws must be purchased separately.

2. **For portable use**, place the saw on a 3/4 in. thick piece of plywood. Bolt the base of the miter saw securely to the plywood using the mounting holes on the base. Use C-clamps to clamp this mounting board to a stable work surface at the worksite.



Fig. Q

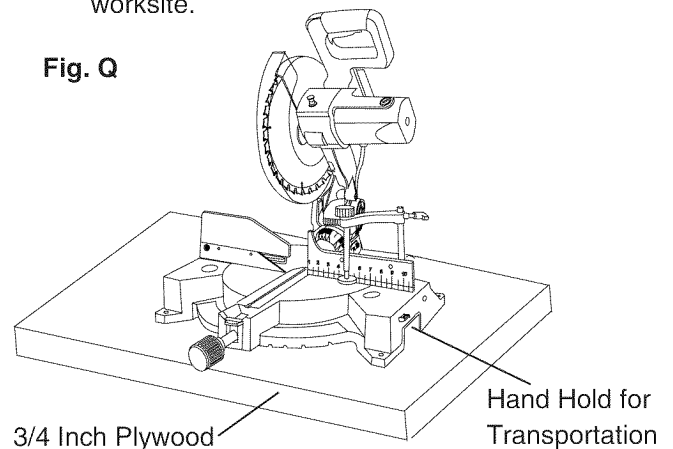

THE LASER GUIDE (FIG. R)

▲ WARNING

1. To turn laser on, press on/off rocker switch (1) to “ON” position.
2. To turn off laser, press on/off rocker switch (1) to “OFF” position.

Fig. R

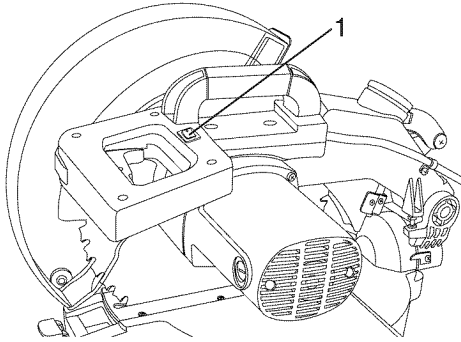

Your tool is equipped with the Laser guide using Class II laser beam. The laser beam will enable to preview the saw blade path on the stock to be cut before starting the miter saw. This laser guide is powered by the transformed alternating current supply directly through the power lead. **The saw must be connected to the power source and the laser on/off switch must be turned on for the laser line to show.**

▲ WARNING

- **AVOID DIRECT EYE CONTACT**
Laser radiated when laser guide is turned on.
Avoid direct eye contact.
- **Laser Warning Label: Max output <1mW DIODE LASER: 630-670nm, Complies with 21CFR 1040.10 and 1040.11.**

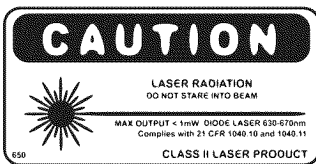

- **CAUTION-Use of controls or adjustments or performance of procedures other than those specified herein may result in hazardous radiation exposure.**
- **CAUTION-The use of optical instruments with this product will increase eye hazard.**
- **Do not attempt to repair or disassemble the laser. If unqualified persons attempt to repair this laser product, serious injury may result. Any repair required on this laser product should be performed by authorized service center personnel.**

OPERATION

SAFETY INSTRUCTIONS FOR BASIC SAW OPERATION

BEFORE USING THE MITER SAW

WARNING

To avoid mistakes that could cause serious, permanent injury, do not plug the tool in until the following steps are completed:

- Completely assemble and adjust the saw, following the instructions. **(ASSEMBLY AND ADJUSTMENTS)**
- Learn the use and function of the ON/OFF switch, lock-off switch, upper and lower blade guards, hold down latch, bevel lock handle and cover plate screws.
- Review and understand all safety instructions and operating procedures in this Operator's Manual. **(SAFETY & OPERATIONS)**
- Review the **MAINTENANCE** and **TROUBLESHOOTING GUIDE** for your miter saw.
- To avoid injury or possible death from electrical shock:
Make sure your fingers do not touch the plug's metal prongs when plugging or unplugging your miter saw. **(ELECTRICAL REQUIREMENTS AND SAFETY)**

BEFORE EACH USE INSPECT YOUR SAW.

- **Disconnect the miter saw.** To avoid injury from accidental starting, unplug the saw before any adjustments, including set-up and blade changes.
- **Compare the direction of rotation arrow** on the guard to the direction arrow on the blade. The blade teeth should always point downward at the front of the saw.
- **Tighten the arbor bolt.**
- **Tighten the cover plate screw.**
- **Check for damaged parts.** Check for:
 - Alignment of moving parts
 - Damaged electric cords
 - Binding of moving parts
 - Mounting holes
 - Function of arm return spring and lower guard: Push the cutting arm all the way down, then let it rise until it stops. The lower guard should fully close. Follow instructions in **TROUBLESHOOTING GUIDE** for adjustment if necessary.
 - Other conditions that may affect the way the miter saw works.
- Keep all guards in place, in working order and proper adjustment. If any part of this miter saw is

missing, bent, damaged or broken in any way, or any electrical parts don't work, turn the saw off and unplug it.

- Replace bent, damaged, missing or defective parts before using the saw again.
- Maintain tools with care. Keep the miter saw clean for best and safest performance. Follow instructions for lubricating. Do not put lubricants on the blade while it is spinning.
- Remove adjusting wrench from the tool before turning it on.
- To avoid injury from jams, slips, or thrown pieces, use only recommended accessories.

RECOMMENDED ACCESSORIES

- Consult the ACCESSORIES and ATTACHMENTS section of this Operators Manual for recommended accessories. Follow the instructions that come with the accessory. The use of improper accessories may cause risk of injury to persons.
- Choose the correct 12 in. diameter blade for the material and the type of cutting you plan to do.
- Make sure the blade is sharp, undamaged and properly aligned. With the saw unplugged, push the cutting arm all the way down. Manually spin the blade and check for clearance. Tilt the power-head to a 45° bevel and repeat the test.
- Make sure the blade and arbor collars are clean.
- Make sure all clamps and locks are tight and there is no excessive play in any parts.

KEEP YOUR WORK AREA CLEAN

Cluttered areas and benches invite accidents.

WARNING

To avoid burns or other fire damage, never use the miter saw near flammable liquids, vapors, or gases.

- Plan ahead to protect your eyes, hands, face and ears.
- Know your miter saw. Read and understand the Operator's Manual and labels affixed to the tool. Learn its application and limitations as well as the specific potential hazards peculiar to this tool. To avoid injury from accidental contact with moving parts, do not do layout, assembly, or setup work on the miter saw while any parts are moving.
- Avoid accidental starting, make sure the trigger switch is disengaged before plugging the miter saw into a power outlet.

PLAN YOUR WORK

- Use the right tool. Don't force a tool or attachment to do a job it was not designed to do. Use a different tool for any workpiece that can't be held in a solidly braced, fixed position.

CAUTION: This machine is not designed for cutting masonry, masonry products, ferrous metals (steel, iron, and iron-based metals.) Use this miter saw to cut only wood, wood-like products, or non-ferrous metals. Other material may shatter, bind the blade, or create other dangers. Remove all nails that may be in the workpiece to prevent sparking that could cause a fire. Remove dust bag when cutting non-ferrous metals.

DRESS FOR SAFETY



Any power tool can throw foreign objects into the eyes. This can result in permanent eye damage. Everyday eyeglasses have only impact resistant lenses and are not safety glasses. Glasses or goggles not in compliance with ANSI Z87.1 could seriously injure you when they break.

- Do not wear loose clothing, gloves, neckties or jewelry (rings, watches). They can get caught and draw you into moving parts.
- Wear non-slip footwear.
- Tie back long hair.
- Roll long sleeves above the elbow.
- Noise levels vary widely. To avoid possible hearing damage, wear ear plugs when using any miter saw.
- For dusty operations, wear a dust mask along with safety goggles.

INSPECT YOUR WORKPIECE

Make sure there are no nails or foreign objects in the part of the workpiece being cut.

Plan your work to avoid small pieces that may bind, or that are too small to clamp and get a solid grasp on.

Plan the way you will grasp the workpiece from start to finish. Avoid awkward operations and hand positions. A sudden slip could cause your fingers or hand to move into the blade.

DO NOT OVER-REACH

Keep good footing and balance. Keep your face and body to one side, out of the line of a possible kickback. NEVER stand in the line of the blade.

Never cut freehand:

- Brace your workpiece firmly against the fence and table stop so it will not rock or twist during the cut.
- Make sure there is no debris between the workpiece and the table or fence.
- Make sure there are no gaps between the workpiece, fence and table that will let the workpiece shift after it is cut.

- Keep the cut off piece free to move sideways after it is cut off. Otherwise, it could get wedged against the blade and thrown violently.
- Only the workpiece should be on the saws table.
- Secure work. Use clamps or a vise to help hold the work when it's practical.

USE EXTRA CAUTION WITH LARGE OR ODD SHAPED WORKPIECES.

- Use extra supports (tables, sawhorses, blocks, etc.) for workpieces large enough to tip.
- Never use another person as a substitute for a table extension, or as an additional support for a workpiece that is longer or wider than the basic miter saw table, or to help feed, support, or pull the workpiece.
- Do not use this saw to cut small pieces. If the workpiece being cut would cause your hand or fingers to be within 8-3/4 inches of the saw blade the workpiece is too small. Keep hands and fingers out of the "no hands zone" area marked on the saws table.
- When cutting odd shaped workpieces, plan your work so it will not bind in the blade and cause possible injury. Molding, for example, must lie flat or be held by a fixture or jig that will not let it move when cut.
- Properly support round material such as dowel rods, or tubing, which have a tendency to roll when cut, causing the blade to "bite".

WARNING

To avoid injury, follow all applicable safety instructions, when cutting non-ferrous metals:

- Use only saw blades specifically recommended for non-ferrous metal cutting.
- Do not cut metal workpieces that must be hand held. Clamp workpieces securely.
- Cut non-ferrous metals only if you are under the supervision of an experienced person and the dust bag has been removed from the saw.

WHEN SAW IS RUNNING

WARNING

Do not allow familiarity from frequent use of your miter saw to result in a careless mistake. A careless fraction of a second is enough to cause a severe injury.

Before cutting, if the saw makes an unfamiliar noise or vibrates, stop immediately. Turn the saw OFF. Unplug the saw. Do not restart until finding and correcting the problem.

BODY AND HAND POSITION (FIG. S)

▲ WARNING



Never place hands near the cutting area. Proper positioning of your body and hands when operating the miter saw will make cutting easier and safer. Keep children away. Keep all visitors at a safe distance from the miter saw. Make sure bystanders are clear of the saw and workpiece. Don't force the saw. It will do the job better and safer at its designed rate.

Starting a cut:

- Place hands at least 8-3/4 in. away from the path of the blade – out of the “no-hands zone” (1). (Fig. S)
- Hold workpiece firmly against the fence to prevent movement toward the blade.
- With the power switch OFF, bring the saw blade down to the workpiece to see the cutting path of the blade.
- Press in lock-off switch in trigger switch handle.
- Squeeze trigger switch to start saw.
- Lower blade into workpiece with a firm downward motion.

Finishing a cut:

- Hold the cutting arm in the down position.
- Release trigger switch and wait for all moving parts to stop before moving your hands and raising the cutting arm.
- If the blade doesn't stop within 6 seconds, unplug the saw and follow the instructions in TROUBLESHOOTING GUIDE section.

Before freeing jammed material:

- Release trigger switch.
- Wait for all moving parts to stop.
- Unplug the miter saw.

Fig. S

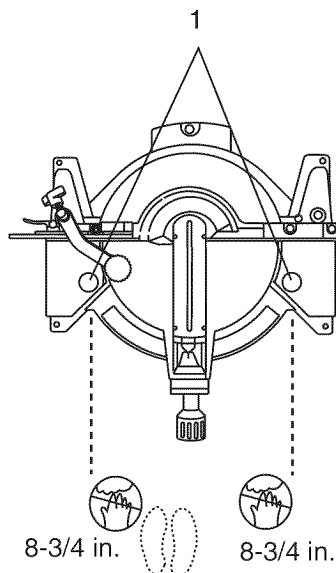

TURNING SAW ON (FIG. T)

To reduce the likelihood of accidental starting, a thumb activated lock-OFF switch is located on top of the switch handle. The lock-OFF switch (1) must be pressed forward before the trigger switch (2) can be activated and the miter saw started.

▲ WARNING

Make the switch child-proof. Insert a padlock through the hole (3) in the trigger switch and lock it. This will prevent children and other unauthorized users from engaging the trigger switch ON.

Fig. T

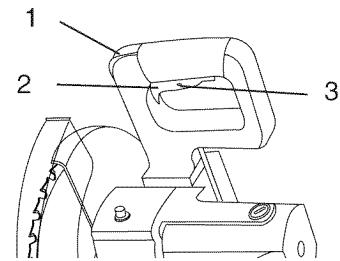

BEFORE LEAVING THE SAW

- Never leave tool running unattended. Turn power OFF. Wait for all moving parts to stop.
- Make workshop child-proof. Lock the shop. Disconnect master switches. Store tool away from children and other unqualified users.

MITER CUT (FIG. U)

1. When a miter cut is required, unlock the miter table by turning the miter handle (1) counterclockwise.
2. While holding the miter handle, press down on the positive stop locking lever (2) to disengage the positive stop locking lever.
3. Rotate the miter table to the right or left with the miter handle.
4. When the table is in the desired position as shown on the miter scale (3), release the positive stop locking lever handle and tighten the miter handle. The table is now locked at the desired angle. Positive stops are provided at 0°, 15°, 22.5°, 31.6° and 45°.

IMPORTANT: ALWAYS TIGHTEN the miter table lock handle before cutting.

Fig. U

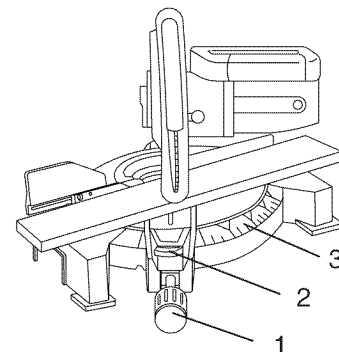

BEVEL CUT (FIG. V)

▲ WARNING

The sliding fence must be extended when marking any bevel cut. Failure to extend the sliding fence will not allow enough space for the blade to pass through which could result in serious injury. At extreme miter or bevel angles the saw blade may also contact the fence.

1. When a bevel cut is required, loosen the bevel lock handle (1).
2. Tilt the cutting head to the desired angle as shown on the bevel scale (2). The blade can be positioned at any angle, from a 90° straight cut (0° on the scale) to a 45° left bevel.
3. Tighten the bevel lock handle (1) to lock the cutting head in position.

Fig. V

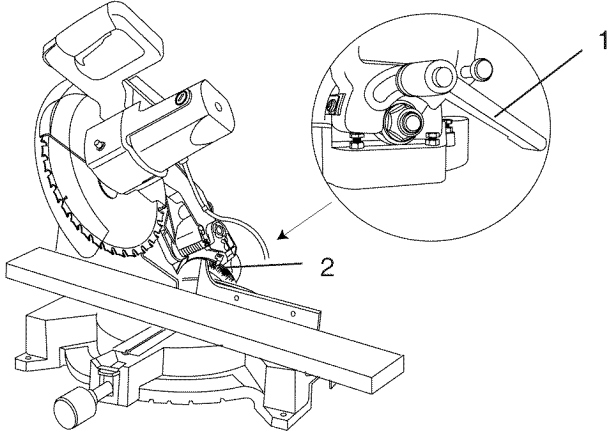

NOTE: The saw comes with a 33.9° bevel detent pin for setting up crown molding cuts when the angle of the walls equals 90°.

33.9° BEVEL DETENT PIN FOR CROWN MOLDING (FIG. W)

1. Push the bevel detent stop pin (2) in toward the front of the machine.
2. Loosen the bevel lock handle (1).
3. Rotate the cutting head until the bevel detent pin stops the bevel angle at 33.9° on the bevel scale.
4. Tighten the bevel lock handle before you make your cut.

Fig. W

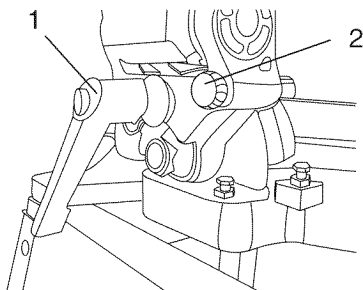

COMPOUND CUT (FIG. X)

A compound cut is the combination of a miter and a bevel cut simultaneously.

1. Loosen the bevel lock handle (1) and position the cutting head at the desired bevel position. Lock the bevel lock handle.
2. Loosen the miter table lock handle (2). Press down the positive stop locking lever (3) and position the table at the desired angle. Release the positive stop locking lever and lock the miter handle.

Fig. X

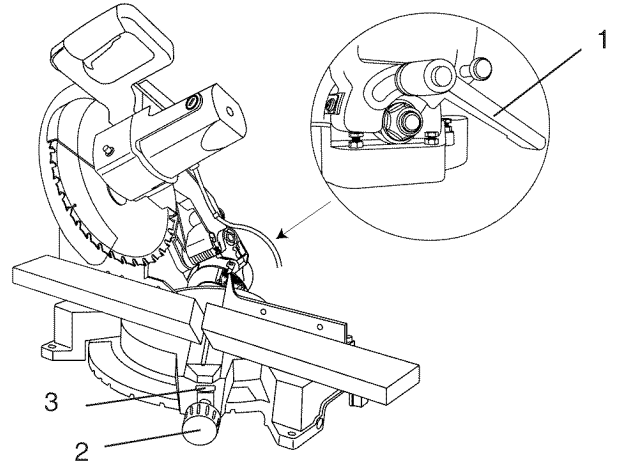

CUTTING BOWED MATERIAL (FIG. Y)

A bowed workpiece must be positioned against the fence and secured with a clamping device as shown before cutting. Do not position workpiece incorrectly or try to cut the workpiece without the support of the fence. This will cause the blade to bind and could result in personal injury.

Fig. Y

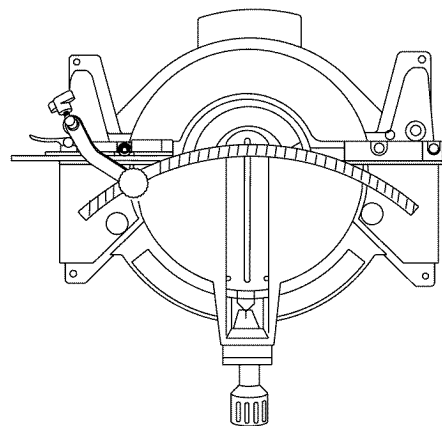

SLIDING FENCE (FIG. Z)

WARNING

The sliding fence must be extended when making any bevel cut. The sliding fence note three bevel angles where the user must adjust the fence to match the degree of the bevel cut. Failure to extend the sliding fence will not allow enough space for the blade to pass through which could result in serious injury. At extreme mitre or bevel angles the saw blade may also contact the fence.

1. Unlock the fence cam locking lever (1) by pushing it toward the rear of the machine.
2. Extend the fence (2) by sliding it out to match the degree of the bevel cut. Lock the fence cam locking lever by pushing it IN toward the fence. **NOTE:** When transporting the saw, always secure the sliding fence in the collapsed position (toward the saw blade).

Fig. Z

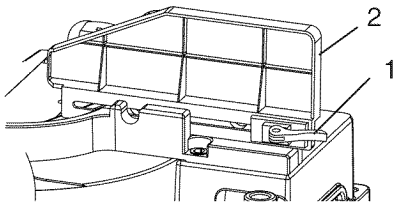

WORKPIECE SUPPORT (FIG. AA)

Long pieces need extra support. The support should be placed under the workpiece. Keep your hand holding the workpiece positioned 8-3/4 inches or more away from the blade. The support must let the workpiece lay flat on the work table during the cutting operation.

NOTE: When mounted on a flat surface, the miter saw table is 3-1/8 inches high.

Fig. AA

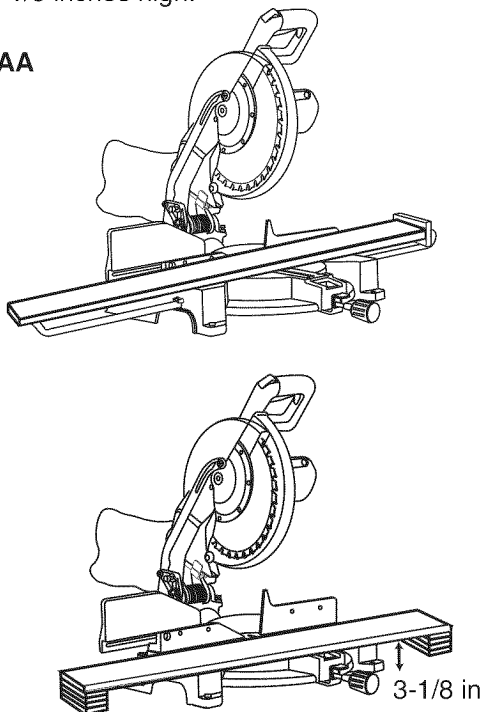

AUXILIARY WOOD FENCE (FIG. BB)

When making multiple or repetitive cuts that result in cut-off pieces of one inch or less, it is possible for the saw blade to catch the cut-off piece and throw it out of the saw or into the blade guard and housing, possibly causing damage or injury. To minimize this, an auxiliary wood fence can be mounted to your saw.

Holes are provided in the saw fence to attach an auxiliary wood fence. This fence is to be constructed of straight wood approximately 3/4 in. thick by 2-1/2 in. high by 22 in. long.

Attach the wood fence securely and make a full depth cut to make a blade slot.

Check for interference between the wood fence and the lower blade guard. Adjust if necessary.

NOTE: This auxiliary fence is used only with the saw blade in the 0° bevel position (90° to the table). The auxiliary wood fence must be removed when bevel cutting.

Fig. BB

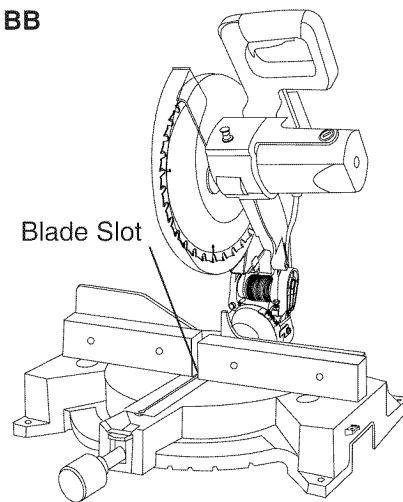

Cutting Capacity Auxiliary Fence	
Crosscut	3-1/2 in. x 3-1/2 in
Miter 45° R & L	3-1/2 in. x 2 in
Bevel 45° L	2 in. x 3-1/2 in.
Compound 45° L, 45° R & L	2 in. x 2 in.

CUTTING BASE MOLDING (FIG. CC)

Base moldings and many other moldings can be cut on a compound miter saw. The setup of the saw depends on molding characteristics and application, as shown. Perform practice cuts on scrap material to achieve best results:

1. Always make sure moldings rest firmly against fence and table. Use hold-down or C-clamps, whenever possible, and place tape on the area being clamped to avoid marks.
2. Reduce splintering by taping the cut area prior to making cut. Mark cut line directly on the tape.
3. Splintering typically happens due to wrong blade application and thickness of the material.

Fig. CC

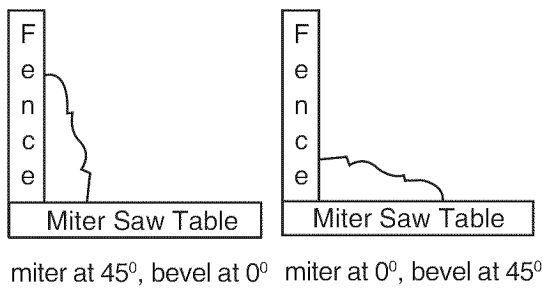

NOTE: Always perform a dry run cut so you can determine if the operation being attempted is possible before power is applied to the saw.

CUTTING CROWN MOLDING (FIG. DD, EE)

NOTE: The chart below references a compound cut for crown molding ONLY WHEN THE ANGLE BETWEEN THE WALLS EQUALS EXACTLY 90°.

Your compound miter saw is suited for the difficult task of cutting crown molding. To fit properly, crown molding must be compound-mitered with extreme accuracy. The two surfaces on a piece of crown molding that fit flat against the ceiling and wall are at angles that, when added together equal exactly 90°.

Most crown molding has a top rear angle (the section that fits flat against the ceiling) of 52° and a bottom rear angle (the section that fits flat against the wall) of 38°.

In order to accurately cut crown molding for a 90° inside or outside corner, lay the molding with its broad back surface flat on the saw table.

When setting the bevel and miter angles for compound miters, remember that the settings are interdependent; changing one changes the other, as well.

Fig. DD

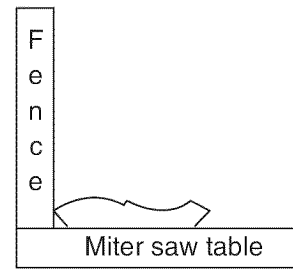

Bevel/Miter Settings

Fig. EE

Settings for standard crown molding lying flat on compound miter saw table

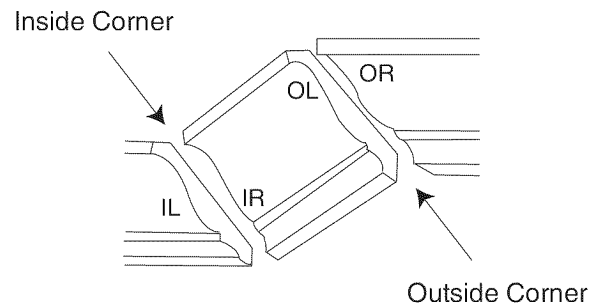

Compound Cut Crown Moldings

NOTE: The chart below references a compound cut for crown molding ONLY WHEN THE ANGLE BETWEEN THE WALLS EQUALS EXACTLY 90°.

KEY	BEVEL SETTING	MITER SETTING	TYPE OF CUT
Inside corner-Left side			
IL	33.9°	31.6° Right	1. Position top of molding against fence. 2. Miter table set at RIGHT 31.6°. 3. LEFT side is finished piece.
Inside corner-Right side			
IR	33.9°	31.6° Left	1. Position bottom of molding against fence. 2. Miter table set at LEFT 31.6°. 3. LEFT side is finished piece.
Outside corner-Left side			
OL	33.9°	31.6° Left	1. Position bottom of molding against fence. 2. Miter table set at LEFT 31.6°. 3. RIGHT side is finished piece.
Outside corner-Right side			
OR	33.9°	31.6° Right	1. Position top of molding against fence. 2. Miter table set at RIGHT 31.6°. 3. RIGHT side is finished piece.

MAINTENANCE

MAINTENANCE

⚠ DANGER

To avoid injury, never put lubricants on the blade while it is spinning.

⚠ WARNING

To avoid fire or toxic reaction, never use gasoline, naphtha acetone, lacquer thinner or similar highly volatile solvents to clean the miter saw.

⚠ WARNING

To avoid injury from unexpected starting or electrical shock, unplug the power cord before working on the saw.

⚠ WARNING

For your safety, this saw is double-insulated. To avoid electrical shock, fire or injury, use only parts identical to those identified in the parts list. Reassemble exactly as the original assembly to avoid electrical shock.

REPLACING CARBON BRUSHES (FIG. FF)

Replace both carbon brushes when either has less than 1/4 in. length of carbon remaining, or if the spring or wire is damaged or burned. To inspect or replace brushes, first unplug the saw. Then remove the black plastic cap (1) on the side of the motor (2). Remove the cap cautiously, because it is springloaded. Then pull out the brush and replace. Replace for the other side. To reassemble reverse the procedure. The ears on the metal end of the assembly go in the same hole the carbon part fits into. Tighten the cap snugly, but do not overtighten.

NOTE: To reinstall the same brushes, first make sure the brushes go back in the way they came out. This will avoid a break-in period that reduces motor performance and increases wear.

Fig. FF

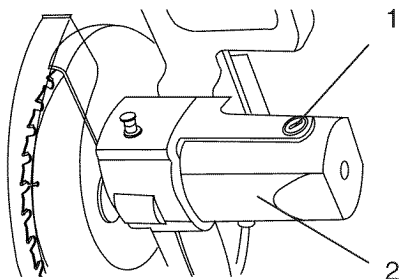

LOWER BLADE GUARD

Do not use the saw without the lower blade guard. The lower blade guard is attached to the saw for your protection. Should the lower guard become damaged,

do not use the saw until the damaged guard has been replaced. Develop a regular check to make sure the lower guard is working properly. Clean the lower guard of any dust or buildup with a damp cloth.

CAUTION: Do not use solvents on the guard. They could make the plastic “cloudy” and brittle.

⚠ WARNING

When cleaning the lower guard, unplug the saw from the power source receptacle to avoid unexpected startup.

SAWDUST

Periodically, sawdust will accumulate under the work table and base. This could cause difficulty in the movement of the worktable when setting up a miter cut. Frequently blow out or vacuum up the sawdust.

⚠ WARNING

If blowing sawdust, wear proper eye protection to keep debris from blowing into eyes.

LUBRICATION (FIG. GG, HH)

All the motor bearings in this tool are lubricated with a sufficient amount of high grade lubricant for the life of the unit under normal operating conditions; therefore, no further bearing lubrication is required.

Lubricate the following as necessary:

Chop pivot: Apply light machine oil to points indicated in illustration.

Fig. GG

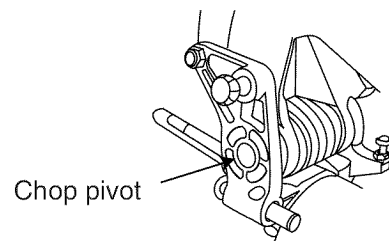

Central pivot of plastic guard: Use light household oil (sewing machine oil) on metal-to-metal or metal-to-plastic guard contact areas as required for smooth, quiet operation. Avoid excessive oil, to which sawdust will cling.

Fig. HH

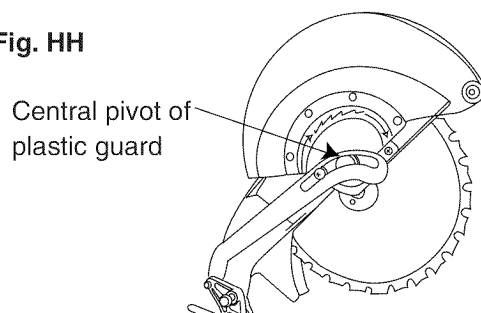

TROUBLESHOOTING GUIDE

WARNING

To avoid injury from accidental starting, always turn switch OFF and unplug the tool before moving, replacing the blade or making adjustments.

TROUBLESHOOTING GUIDE - MOTOR

PROBLEM	PROBLEM CAUSE	SUGGESTED CORRECTIVE ACTION
Brake does not stop blade within 6 seconds.	<ol style="list-style-type: none"> 1. Motor brushes not sealed or lightly sticking. 2. Motor brake overheated from use of defective or wrong size blade or rapid ON/OFF cycling. 3. Arbor bolt loose. 4. Brushes cracked, damaged, etc. 5. Other. 	<ol style="list-style-type: none"> 1. Inspect/clean/replace brushes. See MAINTENANCE section. 2. Use a recommended blade. Let cool down. See REMOVING OR INSTALLING THE BLADE section. 3. Retighten. See REMOVING OR INSTALLING THE BLADE section. 4. Replace brushes. 5. Contact Sears Service Center.
Motor does not start	<ol style="list-style-type: none"> 1. Limit switch failure 2. Brush worn. 3. Fuse blown or circuit breaker tripped on home panel. 	<ol style="list-style-type: none"> 1. Replace limit switch. 2. Replace brushes. See MAINTENANCE section. 3. Verify there is electrical power at the outlet.
Brush spark when switch released.	<ol style="list-style-type: none"> 1. Brush worn. 2. Other. 	<ol style="list-style-type: none"> 1. Replace Brushes. See MAINTENANCE section. 2. Contact Sears Service Center.

TROUBLESHOOTING GUIDE - SAW OPERATION

PROBLEM	PROBLEM CAUSE	SUGGESTED CORRECTIVE ACTION
Blade hits table.	<ol style="list-style-type: none"> 1. Misalignment. 	<ol style="list-style-type: none"> 1. See ADJUSTMENT - Cutting Arm Travel section.
Angle of cut not accurate. Can not adjust miter.	<ol style="list-style-type: none"> 1. Miter table unlocked. 2. Sawdust under table. 	<ol style="list-style-type: none"> 1. See OPERATION - Miter Angle Adjustment section. 2. Vacuum or blow out dust. WEAR EYE PROTECTION.
Cutting arm wobbles.	<ol style="list-style-type: none"> 1. Loose pivot points. 	<ol style="list-style-type: none"> 1. See ADJUSTMENT - Cutting Arm Travel section.
Cutting arm will not fully raise, or blade guard won't fully close.	<ol style="list-style-type: none"> 1. Pivot bolt too tight. 2. Pivot spring not replaced properly after service. 3. Sawdust build-up. 	<ol style="list-style-type: none"> 1. Loosen pivot bolt lock nut (see adjustment section). 2. Contact Sears Service Center. 3. Clean and lubricate moving parts.
Blade binds, jams, burns wood.	<ol style="list-style-type: none"> 1. Improper operation. 2. Dull or warped blade. 3. Improper blade size. 4. Wood is moving during cut. 	<ol style="list-style-type: none"> 1. See BASIC SAW OPERATION section. 2. Replace or sharpen blade. 3. Replace with 12 in. diameter blade. 4. Use hold down clamp to secure workpiece to table.
Saw vibrates or shakes.	<ol style="list-style-type: none"> 1. Saw blade not round / damaged / loose. 2. Arbor bolt loose. 	<ol style="list-style-type: none"> 1. Replace blade. 2. Tighten arbor bolt.

PARTS LIST

12 in. COMPOUND MITER SAW

MODEL NO. 137.212170



When servicing use only CRAFTSMAN replacement parts. Use of any other parts may create a HAZARD or cause product damage. Any attempt to repair or replace electrical parts on this Miter Saw may create a HAZARD unless repair is done by a qualified service technician. Repair service is available at your nearest Sears Service Center.

PARTS LIST FOR SAW SCHEMATIC

I.D.	Description	Size	QTY	I.D.	Description	Size	QTY
083R	TRIGGER		1	0V8L	LOCKING HANDLE ASS'Y		1
083Y	COMPRESSION SPRING		1	0XK9	BUTTON SWITCH		1
083Z	CORD CLAMP		1	0XKA	SEGMENT HANDLE		1
0CES	COMPRESSION SPRING		1	2258	SPECIAL BOLT		1
0CF1	ANCHOR BLOCK		1	2754	WARNING LABEL		1
0CF5	SHAFT-PIVOT		1	2911	ANGLE PEGULATOR	#AW	1
0CH1	SHAFT-PIVOT		1	2948	WARNING LABEL		2
0CH2	SLEEVE		1	20S3	LOCKING HANDLE ASS'Y		1
0CH3	COLLAR		1	20X5	ASSIST-FENCE	#AW	1
0CHF	SPRING GUARD		1	23LN	KNOB-HANDLE		2
0CHG	BUMPER		1	23NX	GUARD-CORD		1
0CHH	CUTTER SHAFT GUARD		1	23TD	SHAFT-PIVOT		1
0CHN	SHIM		2	23TE	POINTER		1
0CJ2	SHAFT SLEEVE		2	23TG	TABLE	#AW	1
0CKS	SPRING WIRE		1	23TH	BASE	#AW	1
0CPD	CENTER BOLT		1	23TU	ROTATION SLIDE PLATE		1
0D7B	SLIDE PLATE		3	23UL	CLEVIS PIN		1
0DT4	ROLLING WHEEL		1	23V1	NEEDLE POINTER	#23	1
0DT7	BEARING		1	23V9	TORSION SPRING		1
0DTZ	ARBOR COLLAR		2	250Z	HEX. SOC. HD. CAP SCREW	M5*0.8-35	4
0DVJ	BLADE WRENCH		1	25V2	KNOB		2
0F1H	COLLAR		1	26DR	HOUSING ASS'Y		1
0J4D	FLAT WASHER	φ5*10-1	1	26LU	WARNING LABEL		1
0J4N	FLAT WASHER	φ16*30-3	1	27AE	COLLAR		1
0J6A	FLAT WASHER	φ8*16-2.5	1	28AE	TABLE INSERT		1
0J70	FLAT WASHER	1/4*3/4-7/64	2	28F8	LOCKING HANDLE ASS'Y		1
0JAF	EXTERNAL TOOTH LOCK WASHER	φ5	1	28JF	LEVER		1
0JB0	WAVE WASHER	WW-8	1	290M	CAUTION LABEL		1
0JFB	SELF-LOCKING RING		1	294S	FLAT WASHER	φ10*25-3	1
0JMP	O-RING		1	2E63	ROCKER SWITCH		1
0JMR	O-RING ROD		1	2C89	NEEDLE POINTER	#23	1
0JPC	HEX. HD. BOLT	M6*1.0-12	1	2CGT	SLOTTED SET SCREW	M6*1.0-8	4
0JRO	HEX. HD. BOLT	M6*1.0-20	4	2D92	CONTROLLER ASS'Y		1
0JXA	HEX. SOC. SET SCREW	M6*1.0-12	2	2DUY	LEAD WIRE ASS'Y		1
0JXB	HEX. SOC. SET SCREW	M6*1.0-16	1	2E0D	PLASTIC SLEEVE		1
0JZN	ARBOR BOLT	M8*1.25-20	1	2E21	CR. RE. TRUSS HD. SCREW		2
0K0X	HEX. HD. SCREW AND WASHER	M6*1.0-16	2	2F76	FENCE	#AW	1
0K2L	HEX. SOC. HD. CAP SCREW	M8*1.25-30	3	2F8L	MOTOR		1
0K4D	CR. RE. PAN HD. SCREW & WASHER	M6*1.0-12	1	2F8M	COIL SPRING		1
0K7X	CR. RE. TRUSS HD. ROUND NECK SCREW	M6*1.0-10	1	2F8Y	DUST BAG ASS'Y		1
0KA9	CR. RE. PAN HD. TAPPING SCREW	M3*24-10	1	2F9N	STICKER		1
0KAD	CR. RE. PAN HD. TAPPING SCREW	M4*0.7-8	6	2K96	WARNING LABEL		1
0KB8	CR. RE. PAN HD. TAPPING SCREW	M4*18-20	2	2KWY	CABLE SHIELD		1
0KB9	CR. RE. PAN HD. TAPPING SCREW	M5*16-10	1	2L0B	LASER PLUNGER HOUSING		1
0KBD	CR. RE. PAN HD. TAPPING SCREW	M4*18-25	4	2L10	CABLE SHIELD		1
0KD6	CR. RE. PAN HD. SCREW	M4*0.7-8	4	2L11	PLUNGER HOUSING ASS'Y		1
0KDN	CR. RE. PAN HD. SCREW	M5*0.8-25	1	2LSZ	HOLD DOWN CLAMP ASS'Y		1
0KDR	CR. RE. PAN HD. SCREW	M5*0.8-10	3	2LWF	CLEVIS PIN		1
0KE0	CR. RE. PAN HD. SCREW	M6*1.0-40	2	2LWG	MOTOR HANDLE		1
0KE1	CR. RE. PAN HD. SCREW	M6*1.0-10	1	2LWH	MOTOR HANDLE		1
0KE2	CR. RE. PAN HD. SCREW	M8*1.25-30	1	2LWJ	ARM	#AW	1
0KL1	CR. RE. PAN HD. ROUND NECK SCREW	M6*1.0-12	1	2LWL	BLADE		1
0KNE	HEX. NUT	M6*1.0T=5	4	2M2G	COVER		1
0KR1	LOCK NUT	M16*2.0T=16	1	2M3Y	INSTRUCTION MANUAL		1
0KR4	LOCK NUT	M8*1.25T=8	2	2M6Q	LABEL		1
0KTS	CABLE CLAMP	5/16"	1	2M6R	TILTING SCALE		1
0KUW	TERMINAL		2	2M6S	TRADE-MARK LABEL		1
0LU2	LIMIT SWITCH		1	2M6T	BRACKET-TILT		2
0S1D	EXTENSION WING ASS'Y		1	2MAR	WARNING LABEL		1
0S2B	CR. RE. PAN HD. TAPPING SCREW	M6*1.0-25	2	2MGR	POWER CABLE		1
0STZ	TRADE-MARK LABEL		1				

PARTS LIST AND SCHEMATIC FOR MOTOR

I.D.	Description	Size	QTY
0JCF	SPRING PIN	φ4-30	1
0JX2	HEX. SOC SET SCREW	M5*0.8-6	2
0K44	CR. RE. PAN HD. SCREW & WASHER	M5*0.8-12	3
0KCP	CR. RE. PAN HEAD TAPPING & WASHER SCREW	M5*12-60	2
0KLA	PLASTIC SCREW	M5*0.8-6	2
0Q9K	FLOW GUIDE		1
0QGR	COMPRESSION SPRING		1
0QMK	RUBBER CAP		1
0QMY	PROTECTOR WIRE		1
0QQS	BRUSH HOLDER ASS'Y		2
0QQT	BRUSH ASS'Y		2
0QR0	BRUSH COVER		2
0QR2	BEARING BUSHING		1
144L	LEAD WIRE ASS'Y		1
21AX	CLEVIS PIN		1
23Z3	GEAR BOX	#AW	1
23Z4	MOTOR HOUSING		1
240R	ARMATURE ASS'Y		1
27DB	CUTTER SHAFT ASS'Y		1
2B79	CR. RE. PAN HD. SCREW & WASHER	M5*0.8-35	4
2F8R	FIELD ASS'Y		1
Y3Z9	BALL BEARING	6200ZZ	1
Y3ZY	BALL BEARING	6201ZLU	1

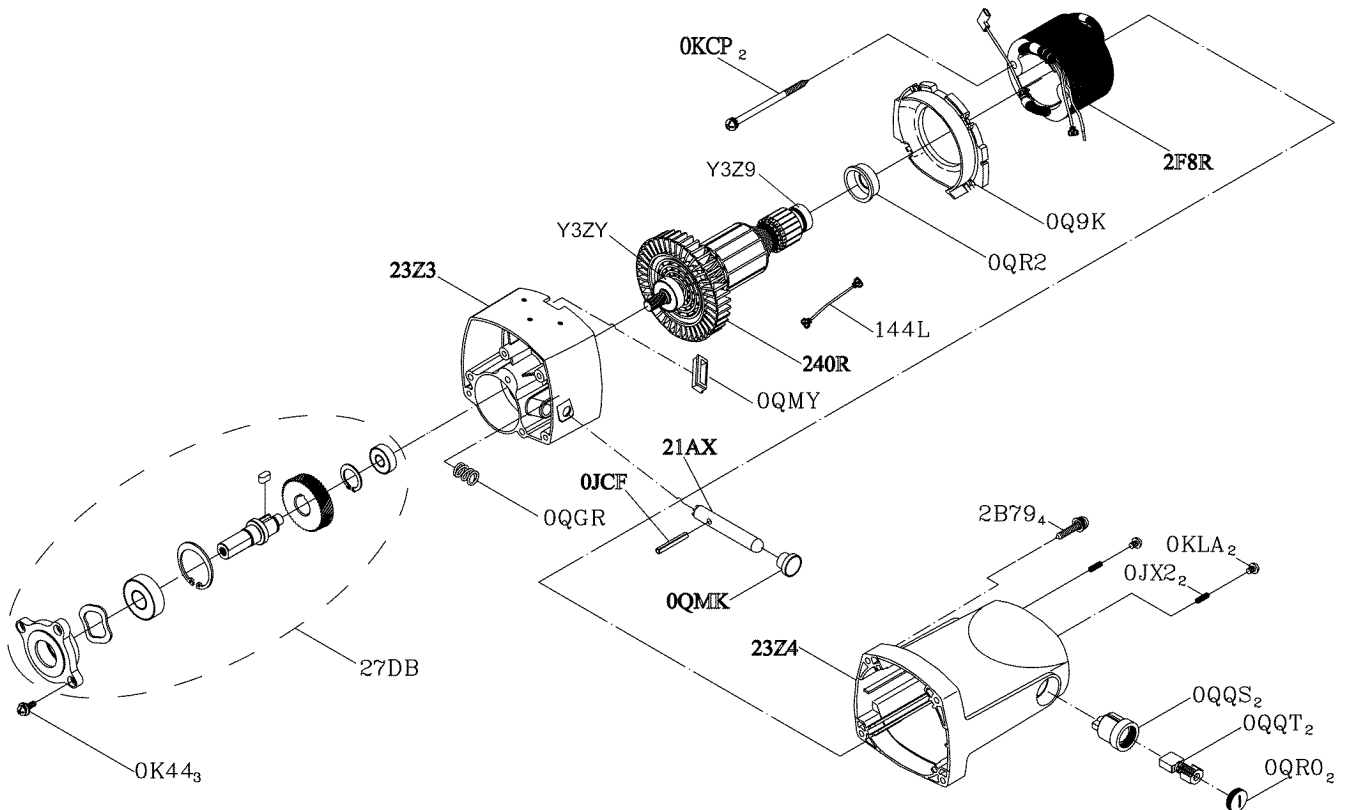

Get it fixed, at your home or ours!

Your Home

For expert troubleshooting and home solutions advice:

manage  **my home**

www.managemyhome.com

For repair – **in your home** – of **all** major brand appliances, lawn and garden equipment, or heating and cooling systems, **no matter who made it, no matter who sold it!**

For the replacement parts, accessories and owner's manuals that you need to do-it-yourself.

For Sears professional installation of home appliances and items like garage door openers and water heaters.

1-800-4-MY-HOME[®] (1-800-469-4663)

Call anytime, day or night (U.S.A. and Canada)

www.sears.com www.sears.ca

Our Home

For repair of carry-in items like vacuums, lawn equipment, and electronics, call anytime for the location of your nearest **Sears Parts & Repair Service Center**

1-800-488-1222 (U.S.A.) **1-800-469-4663** (Canada)

www.sears.com

www.sears.ca

To purchase a protection agreement on a product serviced by Sears:

1-800-827-6655 (U.S.A.)

1-800-361-6665 (Canada)

Para pedir servicio de reparación a domicilio, y para ordenar piezas:

1-888-SU-HOGAR[®]
(1-888-784-6427)

Au Canada pour service en français:

1-800-LE-FOYER^{MC}
(1-800-533-6937)
www.sears.ca



© Registered Trademark / TM Trademark / SM Service Mark of Sears Brands, LLC

© Marca Registrada / TM Marca de Fábrica / SM Marca de Servicio de Sears Brands, LLC

^{MC} Marque de commerce / ^{MD} Marque déposée de Sears Brands, LLC

© Sears Brands, LLC