

SAFETY PRECAUTIONS

Before installing and operating this equipment, be sure everyone involved in its operation is fully trained and aware of precautions. Accidents and problems can be caused by failure to follow fundamental rules and precautions.

The following symbols, found throughout this manual, alert you to potentially dangerous conditions to the operator, service personnel, or to the equipment.



This symbol warns of immediate hazards that will result in severe injury or death.



This symbol refers to a potential hazard or unsafe practice that could result in injury or death.



This symbol refers to a potential hazard or unsafe practice that could result in injury, product damage, or property damage.



This symbol refers to information that needs special attention or must be fully understood, even though not dangerous.

 **WARNING**
FIRE HAZARD
FOR YOUR SAFETY

Do not store or use gasoline or other flammable vapors and liquids in the vicinity of cooking appliances.

Keep area around cooking appliances free and clear of combustibles.

Purchaser of equipment must post in a prominent location detailed instructions to be followed in the event the operator smells gas. Obtain the instructions from the local gas supplier.

 **WARNING**
BURN HAZARD

Contact with hot surfaces will cause severe burns. Always use caution when operating cooking appliances.

 **WARNING**
EXPLOSION AND ASPHYXIATION HAZARD

In the event a gas odor is detected, shut down equipment at the main gas shut-off valve and immediately call the emergency phone number of your gas supplier.

Improper ventilation can result in headaches, drowsiness, nausea, and could result in death. Do not obstruct the flow of combustion and ventilation air to and from cooking appliances.

 **WARNING**
ELECTRIC SHOCK HAZARD

For appliances that use electric power, disconnect the power to the appliance before cleaning. Do not remove panels that require tools to remove.

NOTICE

Southbend appliances are intended for commercial use only. Not for household use.

Warranty will be void if service work is performed by other than a qualified technician, or if other than genuine Southbend replacement parts are installed.

Give this Owner's Manual and important papers to the proper authority to retain for future reference.

INTRODUCTION

Congratulations! You have purchased one of the finest pieces of heavy-duty commercial cooking equipment on the market.

You will find that your new equipment, like all Southbend equipment, has been designed and manufactured to meet the toughest standards in the industry. Each piece of Southbend equipment is carefully engineered and designs are verified through laboratory tests and field installations. With proper care and field maintenance, you will experience years of reliable, trouble-free operation. **For best results, read this manual carefully.**

RETAIN THIS MANUAL FOR FUTURE REFERENCE.

This manual is for Southbend Platinum Series Sectional Ranges.

This manual does NOT cover Southbend sectional fryers, fryer filter systems, salamander broilers, upright broilers, cheese melters, or refrigerated bases. Those appliances have their own manuals.

The location of the serial plate depends on the type of base (see Figure 1 below). On models with oven bases, the serial plate is located on the backside of the kick-plate below the oven door (lift the kick-plate straight up and tilt the top edge out and down.) On models with a cabinet base, the serial plate is located inside the left cabinet door. On modular (countertop) models, the serial plate is located inside the front valve panel.

Read these instructions carefully before attempting installation. Installation and initial startup should be performed by a qualified installer. Unless the installation instructions for this product are followed by a qualified service technician (a person experienced in and knowledgeable with the installation of commercial gas and/or electric cooking equipment) then the terms and conditions on the Manufacturer's Limited Warranty will be rendered void and no warranty of any kind shall apply.

In the event you have questions concerning the installation, use, care, or service of the product, contact:

Southbend Technical Service
1100 Old Honeycutt Road
Fuquay-Varina, North Carolina 27526 USA
www.southbendnc.com

Figure 1

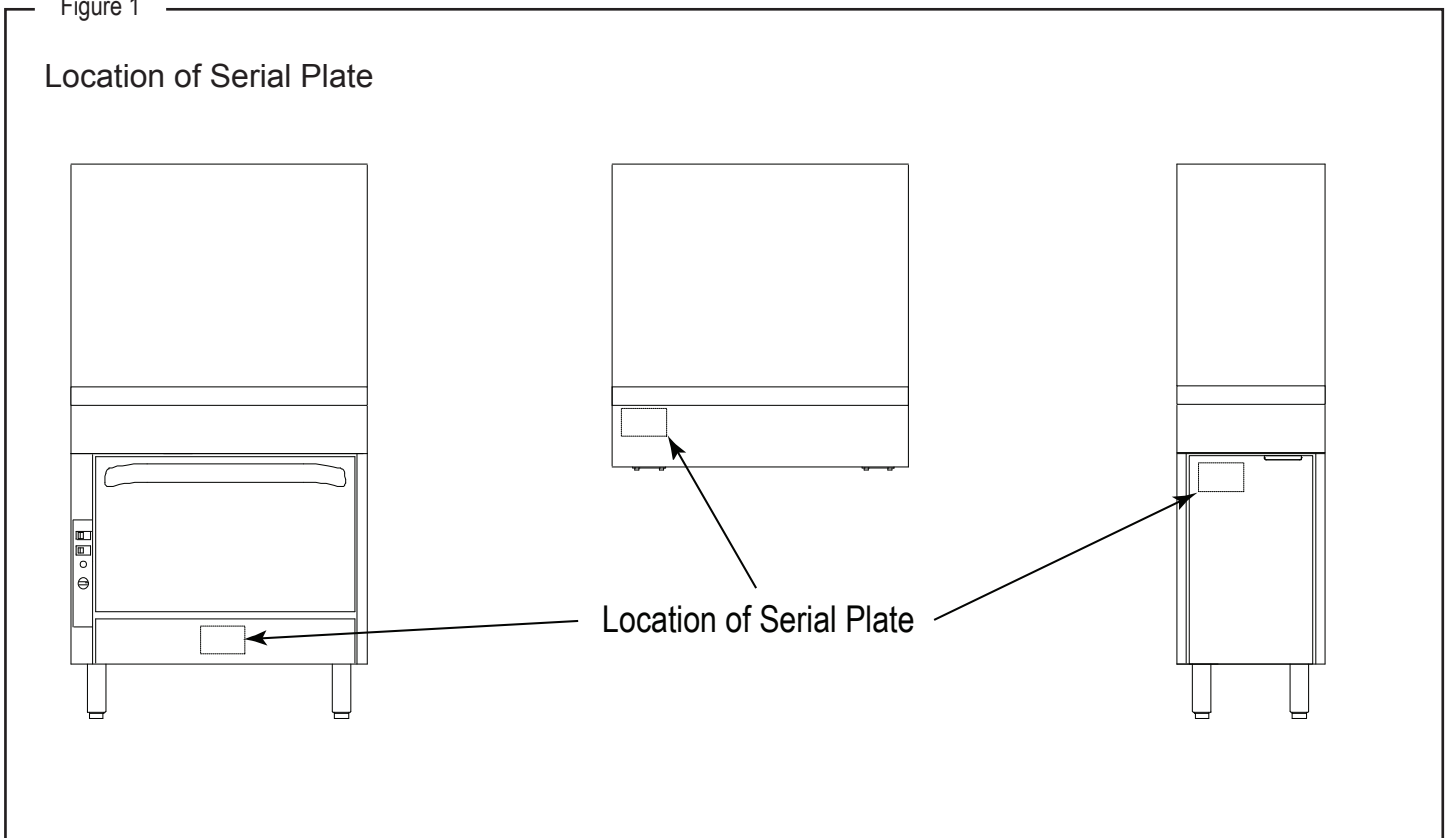

SPECIFICATIONS

NOTICE

Local codes regarding installation vary greatly from one area to another. The National Fire Protection Association, Inc., states in its NFPA 96 latest edition that local codes are the “authority having jurisdiction” when it comes to installation requirements for equipment. Therefore, installations should comply with all local codes.

Southbend reserves the right to change specifications and product design without notice. Such revisions do not entitle the buyer to corresponding changes, additions, or replacements for previously purchased equipment.

Southbend appliances are intended for commercial use only, not for household use.

The installation must conform with local codes, or in the absence of local codes, with the *National Fuel Gas Code, ANSI Z223.1, Natural Gas Installation Code, CAN/CGA-B149.1*, or the *Propane Installation Code CAN/CGA-B149.2*, as applicable, including:

1. The appliance and its individual shutoff valve must be disconnected from the gas supply piping system during any pressure testing of that system at test pressures in excess of 1/2 psi (3.45 kPa).
2. The appliance must be isolated from the gas supply piping system by closing its individual manual shutoff valve during any pressure testing of the gas supply piping system at test pressures equal to or less than 1/2 psi (3.45 kPa).

CLEARANCES



WARNING

MINIMUM CLEARANCES FROM COMBUSTIBLE CONSTRUCTION

There must be adequate clearance between the cooking equipment and combustible construction. Clearance must also be provided for servicing and for operation.

	Open-Top Standard-Burner Models	Open-Top PyroMax-Burner Models	Griddle Models	Uniform Hot-Top Models	Plancha Graduated Hot-Top Models
Sides	10"	13"	10"	10"	6"
Back	6"	6"	12"	12"	6"
Floor*	0"	0"	0"	0"	0"

Do NOT install sectional charbroilers or wood smokers next to combustible materials.

* Models with 6" legs or casters are suitable for installation on combustible floors.

Adequate clearance must be provided in the aisle in front of the unit to permit operation (including opening of doors and/or removal of grease drawers, drippings trays, and/or oven racks), as well as for servicing. No additional clearance is required for servicing as the sectional range is serviceable from the front.

Models with a convection-type oven require a minimum clearance of 2" between the motor on the back and non-combustible construction. Care must be taken to provide adequate air circulation to prevent the motor from overheating.

Minimum clearance from noncombustible construction is zero on the sides and back for all models (except for models with a convection-type oven).

The high-temperature flue products flow out through the top of the flue riser of all models, and from the top of open-top and charbroiler models. Installation under a vented hood is recommended.

Salamander broilers and cheese melters mounted on the flue riser of a sectional range may require additional minimum clearances (see the documentation for those appliances).

VENTILATION

WARNING

Improper ventilation can result in personal injury or death. Ventilation which fails to properly remove flue products can cause headaches, drowsiness, nausea, or could result in death.

All gas appliances must be installed in such a manner that the flow of combustion and ventilation air is not obstructed. Provisions for adequate air supply must be provided. Do not obstruct the area under the control panel or below the oven door (on the front), or the area below the flue riser (on the back) as combustion air enters through these areas.

NOTICE

Proper ventilation is the owner's responsibility. Any problem due to improper ventilation will not be covered by the warranty.

Be sure to inspect and clean the ventilation system according to the ventilation equipment manufacturer's instructions.

Air for combustion enters from the front below the valve panel, as well as from the rear into the burner box. Ranges with solid tops (griddles, planchas and hot-tops) vent their flue products up the flue riser. On units with a base oven, combustion air enters from the front below the oven door. Oven flue products are vented up the flue riser.

Lack of sufficient ventilation will cause poor burner and pilot operating characteristics, resulting in inefficient performance. Such conditions also cause high ambient temperatures at the manifold area and create valve and thermostat problems.

If a ventilation canopy is used, it is recommended that the canopy extend 6" past the sectional range and that the bottom edge be located 6'6" from the floor. Filters should be installed at an angle of 45° or more from the horizontal. This position prevents dripping grease, and facilitates collecting the run-off grease in a drip pan under the filter.

A strong exhaust fan tends to create a vacuum in the room and may interfere with burner performance or may extinguish pilot flames. Fresh air openings approximately equal to the fan area will relieve such a vacuum. The exhaust fan should be installed at least 2" above the top of the flue riser.

If the sectional range is connected directly to an outside flue, a CSA design certified down draft diverter must be installed.

In case of unsatisfactory performance by any gas appliance, check the appliance with the exhaust fan turned OFF. Do this only long enough to check whether doing so corrects any problems with equipment performance. Then turn the exhaust fan back on and let it run to remove any exhaust that may have accumulated during the test.

GAS SUPPLY

The sectional range is design-certified for operation on natural or propane gases. The sectional range is shipped configured and adjusted for the type of gas specified by the purchaser, which is indicated on the serial plate (see Figure 1 on page 3). Connect the sectional range ONLY to the type of gas for which it is configured and adjusted.

Each section has a 1-1/4" front gas manifold that can be coupled to adjacent section(s). Sections can be ordered with an optional 1" rear gas connection with a male NPT connector. Minimum supply pressure is 7" W.C. for natural gas, 11" W.C. for propane. An external pressure regulator and shut off valve must be provided. If using a flexible-hose gas connection, the I.D. of the hose must not be smaller than the connector on the unit and must comply with ANSI Z21.69. Provide an adequate means of restraint to prevent undue strain on the gas connection.

If applicable, the vent line from the gas appliance pressure regulator shall be installed to the outdoors in accordance with local codes, or in the absence of local codes, with the *National Fuel Gas Code, ANSI Z223.1, Natural Gas Installation Code, CAN/CGA-B149.1, or the Propane Installation Code CAN/CGA-B149.2, as applicable.*

An adequate gas supply is imperative. Undersized or low pressure lines will restrict the volume of gas required for satisfactory performance. Fluctuations of more than 25% on natural gas or 10% on propane gas will create problems and affect burner operating characteristics. A 1/8" pressure tap is located on the manifold to measure the manifold pressure. The supply line to the sectional range should be no smaller than the inside diameter of the pipe on the sectional range to which it is connected.

ELECTRICITY SUPPLY

Units with convection-oven bases with optional electronic ignition require electric power (50Hz or 60Hz single-phase AC). 120V models have a 7-foot (2134 mm) power cord with a grounded plug (1.0 amps for “D” Models and 4.8 amps for “A” Models). The 208/240V models have a terminal block for connection to a single-phase 208/240V source (1.0 amps for “D” Models and 2.6 amps for the “A” Models).

The appliance, when installed, must be electrically grounded in accordance with local codes, or in the absence of local codes, with the *National Electrical Code, ANSI/NFPA 70, or the Canadian Electrical Code, CSA C22.2*, as applicable. An electrical diagram is located on the rear of the range, near the motor.

OPERATION

 **DANGER**
EXPLOSION HAZARD

In the event a gas odor is detected, shut down equipment at the main shut off valve. Immediately call the emergency phone number of your gas supplier.

 **CAUTION**

If a pilot flame pilot should go out, the flow of gas to the corresponding burner is NOT interrupted. Consequently, it is the responsibility of the operator to check the ignition of each burner immediately EVERY TIME a burner is turned on. Should ignition fail after 10 seconds, turn off the burner, wait 5 minutes, and then try again.

LIGHTING AFTER GAS HAS BEEN SHUT OFF

When turning on the main gas supply to a sectional range, do the following:

1. Make sure that all the control knobs and power switches of all the connected appliances are in the OFF position.
2. Turn on the gas-supply shut-off valve(s).
3. Light the standing pilots of each connected appliance.
4. Light the ovens of the sectional range first, then wait six minutes before turning on the top sections.

This enables all air to be purged from the sectional-range gas piping.

SHUTDOWN OF ENTIRE RANGE

To place the range in a standby state (ready for use), Oven bases with the electronic ignition option, turn all burner control knobs to OFF, set all thermostats to their lowest position, and switch all ovens OFF. The pilots will remain lit. On the standing pilot units, same as above except turn thermostat knob to the "OFF" position. The pilots will remain lit.

To completely shut down the range for an extended period (or prior to disconnecting the gas supply), place the range in a standby state (as described in the previous paragraph), then turn OFF the manual shut-off valves of all gas supply connections. This will extinguish the pilots.

Figure 8

Operation of Plancha Griddle Sections

Each control knob can be turned to OFF or to any position in the range from low to high.

To start cooking, turn the control knob to HIGH. Check that the burner ignites. **The gas does NOT automatically shut off if the burner does not ignite!** If the burner does not ignite, check and/or light the pilots (see procedure at right). When the burner is hot, the burner flame should appear blue and steady (some slight yellowing of the flame tips may occur when using propane gas).

Always remember to heat the Plancha slowly because quick heating may cause costly damage. Never place utensils on the griddle.

Do not waste gas and abuse equipment by leaving the Plancha on HIGH all the time. Damage to the Plancha and certain electronic components may occur, and **MAY VOID YOUR WARRANTY.**

When necessary while cooking, pull out and empty the grease drawer.

When done cooking, turn the appropriate control knob to OFF. (The pilot should remain lit).

Each burner has a pilot that is lit using the spark igniter push button, (if equipped) or a long match inserted through a hole in the front valve panel. (A 32"-wide Plancha has three pilots.) To light the pilot, do the following:

1. Check that all the control knobs are in the OFF position.
2. Turn on the gas supply to the sectional range (if not already on).
3. Push spark ignition button for approximately 10 seconds.
4. Verify pilots are lit by looking through site holes in valve panel. If spark ignition system is faulty, light pilots manually.
5. Pilots are lit manually by inserting a long match (at least 11" long) or pilot-lighting device straight into the hole on the front valve panel for each burner of the Plancha.

