



SUMMERSET

OUTDOOR OVEN MANUAL



FREE STANDING
SS-OVFS



BUILT IN
SS-OVBI



COUNTER TOP



FOR QUESTIONS OR SERVICE, PLEASE CALL 800.966.8126

Oven Operation 1-2-3

Before Cooking:

- Step 1 Keep your oven a safe distance away from your property.*
- Step 2 Always perform a leak test.*
- Step 3 Keep children away from the oven.

During Cooking:

(To avoid tripping safety valves, please follow these instructions carefully!)

- Step 1 Turn gas tank on slowly.
- Step 2 Use protective gloves when oven gets hot.

After Cooking:

- Step 1 Burn oven for 10-15 minutes to burn off food residue.
- Step 2 Wait until the oven is completely cooled before closing oven door.
- Step 3 Clean up grease build-up and cover your oven.

*** Please refer to the owner's manual for details.**

 **WARNING**

1. Do not store or use gasoline or other flammable liquids or vapors in the vicinity of this or any other appliance.
2. An LP cylinder not connected for use should not be stored in the vicinity of this or any other appliance.

 **DANGER**

If you smell gas:

1. Shut off gas to the appliance.
2. Extinguish any open flame.
3. Open oven door.
4. If odor continues, keep away from the appliance and immediately call your gas supplier or your fire department.

Always read and understand the WARNINGS and INSTRUCTIONS that are contained in this manual before attempting to use this outdoor oven to prevent possible bodily injury or property damage.

TABLE OF CONTENTS

Safety Information.....	4
Package Contents.....	6
Hardware Contents.....	7
Assembly Instructions.....	8
LP Gas Assembly.....	15
Natural Gas Conversion	21
Operating Instructions.....	29
Care and Maintenance.....	32
Troubleshooting	41
Exploded Diagram.....	43
Replacement Parts List.....	45
Island Installation.....	48
Warranty.....	49

Safety Information

Please read and understand this entire manual before attempting to assemble, operate or install the product. If you have any questions regarding the product, please call customer service at 1(800) 966-8126 Monday to Friday from 8:30 a.m. to 5 p.m. PST.

1. The installation of this appliance must conform with local codes or, in the absence of local codes, with either the National Fuel Gas Code, ANSI Z223.1/NFPA 54, or Natural Gas and Propane Installation Code, CSA/CGA-B149.1.
2. This oven is intended for use outdoors and should not be used in a building, garage or any other enclosed area.
3. This outdoor oven is not intended for installation in or on recreation vehicles and/or boats.
4. A minimum clearance of 61 cm (24 inches) from combustible constructions to the sides of the grill and 61 cm (24 inches) from the back of the grill to combustible constructions must be maintained. Do not use this appliance under unprotected combustible overhead construction without an exhaust hood. A minimum of 5 ft clearance must be maintained between the chimney exhaust vent and the overhead combustible or non-combustible construction.
5. The use of an electrical source requires that when installed, the grill must be electrically grounded in accordance with local codes or, in the absence of local codes, with ANSI/NFPA 70, or the Canadian Electrical Code, CSA C22.1. Keep electrical supply cords and the fuel supply hose away from heated surfaces.
6. Inspect the hoses before each use for excessive abrasion or wear, or cuts that may affect safe operation of the grill. If there is evidence of excessive abrasion or wear, or the hose is cut, it must be replaced prior to the grill being put into operation. The replacement hose assembly must be those specified by the manufacturer.
7. Keep your oven in an area clear and free from combustible materials, gasoline and other flammable vapors and liquids.
8. DO NOT obstruct the flow of combustion and ventilation air to this appliance.
9. Keep the ventilation openings of the tank enclosure free and clear from debris.
10. Check all gas connections for leaks with a soapy water solution and brush. Never use an open flame to check for leaks.
11. Never use charcoal in the oven.
12. Never use the grill in windy areas.
13. Only a 9 kg (20 lb.) LP-gas cylinder is allowed. The cylinder must be constructed and marked in accordance with the Specifications for LP Gas Cylinders of the U.S. Department of Transportation (D.O.T.) or the National Standard of Canada, CAN/CSA-B339, Cylinders, Spheres and Tubes for Transportation of Dangerous Goods. A 9 kg (20 lb.) LP-Gas cylinder's dimensions are:
 14. Never use the grill without the drip tray installed and hung under the burner box. Without the drip tray, hot grease and debris could leak downward and produce a fire hazard.
 15. Use only the gas pressure regulator supplied with this appliance.

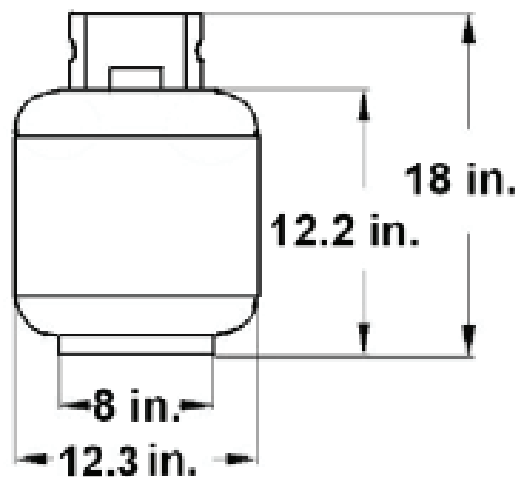

Safety Information

This regulator is set for an outlet pressure of 11.0 WC.

16. The cylinder used must include a collar to protect the cylinder valve

17. Do not store a spare LP-gas cylinder under or near the appliance

18. Never fill the cylinder beyond 80 percent full

19. If the information in “17” and “18” is not followed exactly, a fire causing death or serious injury may occur.

20. The outdoor cooking gas appliance must be isolated from the gas supply piping system by closing its individual manual shutoff valve during any pressure testing of the gas supply system at test pressures equal to or less than 1/2 psi (3.5 kPa).

21. CALIFORNIA PROPOSITION 65 WARNING: The burning of gas cooking fuel generates some byproducts that are on the list of substances known by the State of California to cause cancer, reproductive harm, or other birth defects. To reduce exposure to these substances, always operate this unit according to the use and care manual, ensuring you provide good ventilation when cooking with gas.

IMPORTANT: We urge you to read this manual carefully and follow the recommendations enclosed. This will ensure you receive the most enjoyable and trouble-free operation of your new gas grill. We also advise you retain this manual for future reference.



WARNING: Your outdoor oven has been designed to operate using only the gas specified by the manufacturer on the rating plate. Do not attempt to operate your grill on other gases. Failure to follow this warning could lead to a fire hazard and bodily harm and will void your warranty.



WARNING: Make certain your LP (propane) tank is filled by a reputable propane dealer. An incorrectly filled or an overfilled LP tank can be dangerous. The overfilled condition combined with the warming of the LP tank (a hot summer day, tank left in the sun, etc.) can cause LP gas to be released by the pressure relief valve on the tank since the temperature increase causes the propane to expand. LP gas released from the tank is flammable and can be explosive. Refer to your Owner's Manual for more information concerning filling your LP tank.

PACKAGE CONTENTS

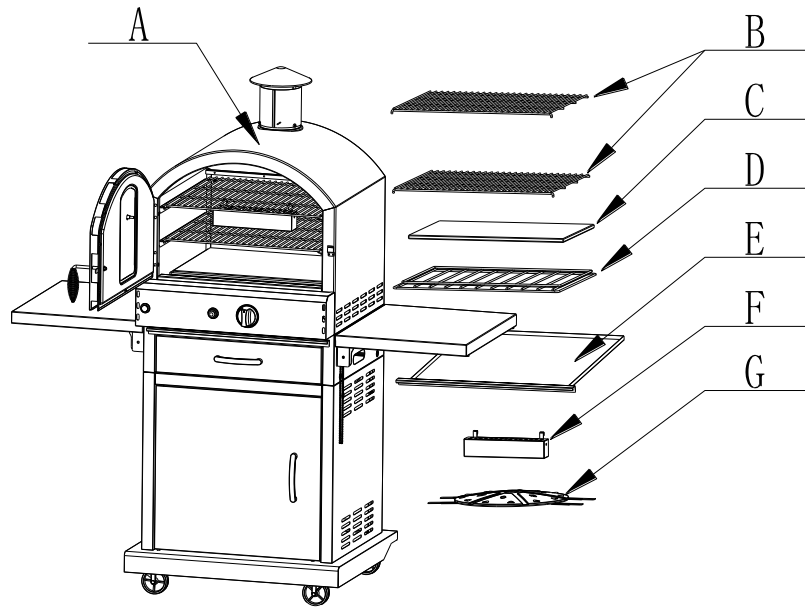

PART	DESCRIPTION	QUANTITY	PART	DESCRIPTION	QUANTITY
A	Main Body	1	E	Drip Tray	1
B	Cooking Grill	2	F	Smoker Box	1
C	Pizza Stone	1	G	Flame Tamer	1
D	Bottom Grill	1			

HARDWARE CONTENTS

The following list is included inside the oven carton:

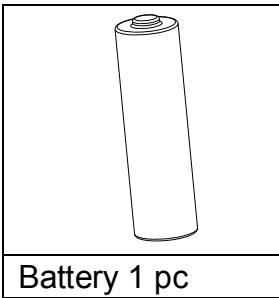

The following list is not included inside the pizza oven carton, but needed when the user is assembling the pizza oven.

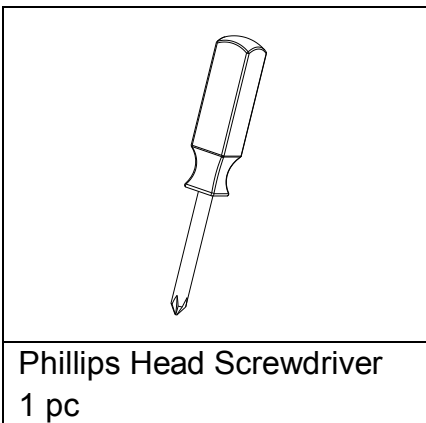

The following list is NOT included inside the pizza oven carton but is included inside the NG Conversion Kit. It is needed when the gas type is changed from LP to NG.

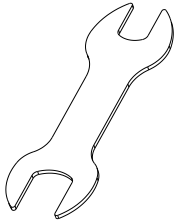
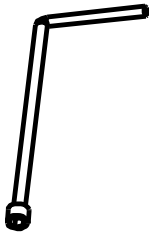
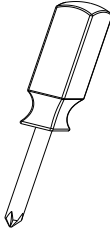
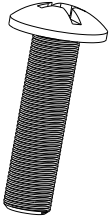
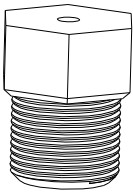
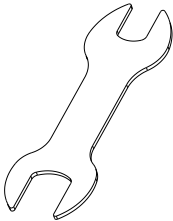
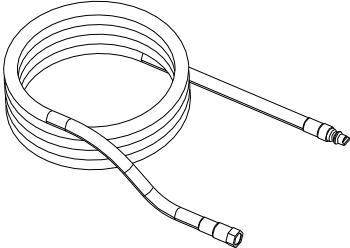
			
11X11 mm Wrench 1 pc	Orifice Removal Tool 1 pc	Phillips Head Screwdriver 1 pc	Conversion Screw 1 pc
			
φ 1.80 Orifice 1 pc	17X19 mm Wrench 1 pc	Natural Gas Hose 1pc	

ASSEMBLY INSTRUCTIONS

Before beginning assembly of product, make sure all parts are present. Compare parts with package contents list and hardware contents list. If any part is missing or damaged, do not attempt to assemble the product.

Assembly tip! (Please lightly tighten the screws during assembly of the cart. When the cart is completed THEN TIGHTEN ALL THE screws. This will make it easier to make all the holes align properly)

1. Use screw **M6*40**× 2 pcs, nut **M6**× 2 pcs and flat washer **18*6.4*1**× 2 pcs to fix the weight under the base panel. **(Note: These screws MUST be tightened at this time as it will be hard to reach them after cart assembly)**

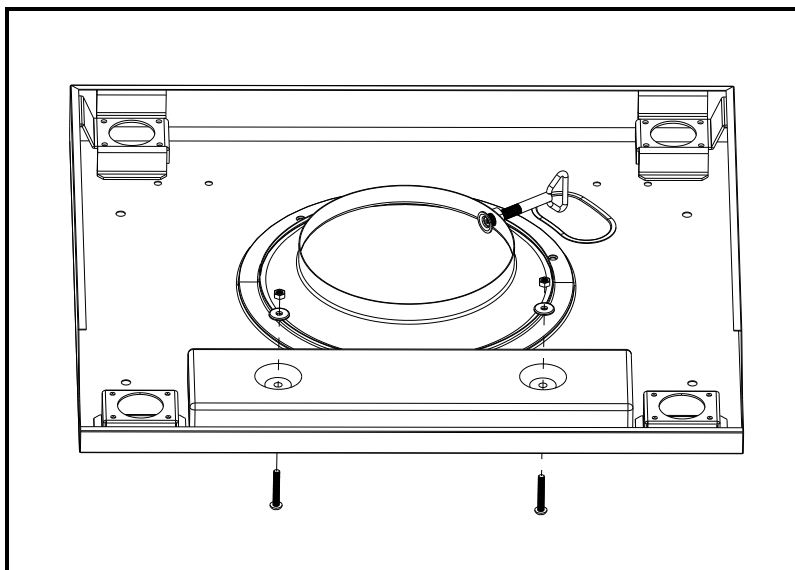

2. Use screw **M6*12**×16 pcs to attach swivel castor with lock×2 pcs and fixed castor×2 pcs onto the bottom of the base panel. **(Note: The locking wheels should go in the BACK of the cart near the weight)**

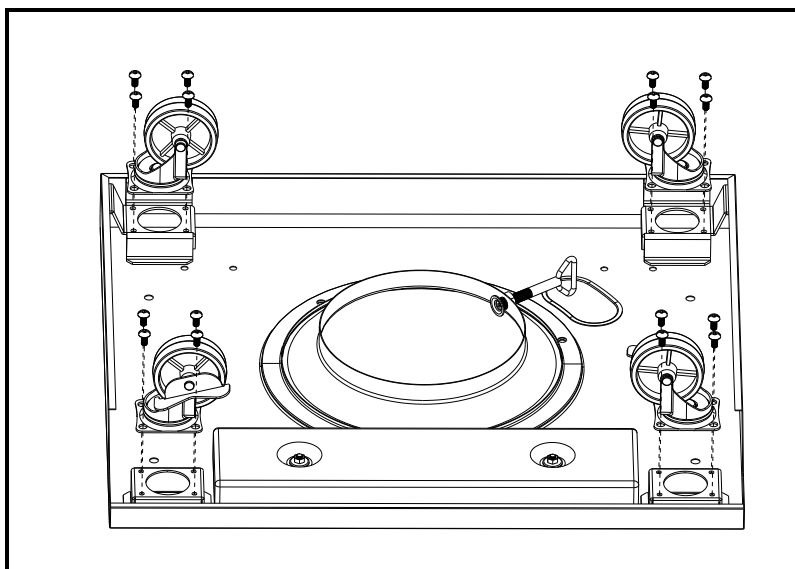

3. Use screw **M6*12×2** pcs to fix the left side panel onto the base panel of the stand. **(Note: The panel should have the “small holes at the top” to the front of the cart assembly)**

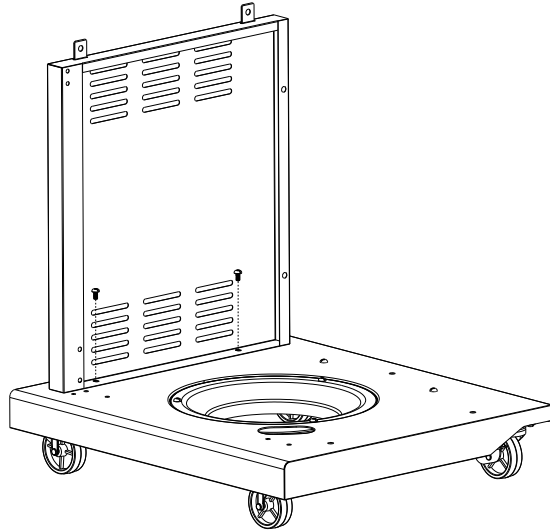

4. Use screw **M3*12×2** pcs and nut **M3×2** pcs to attach the door magnet onto the right side panel. **(Note: Please attach the magnet BEFORE you put the right side panel on. Check to verify that the magnet points to the FRONT of the cart. This holds the door closed)**

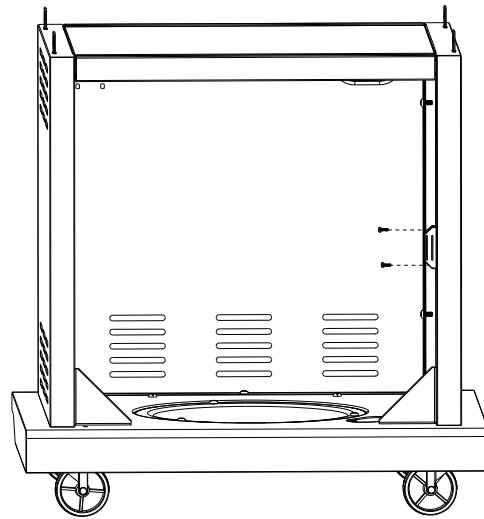

5. Use screw **M6*12×2** pcs to fix the right side panel onto the base panel of the stand. **(Note: The panel should have the “small holes at the top” to the front of the cart assembly. The Right side panel also has the door magnet)**

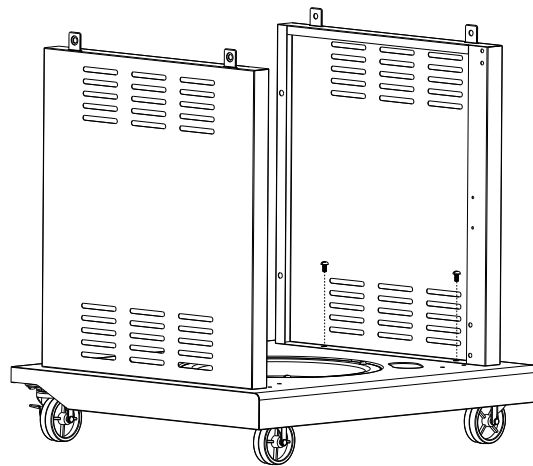

6. Use screw **M4*10**×4 pcs and nut **M4**×4 pcs to attach the transformer assembly onto the outside of the back panel of the stand. **(Note: These screws can be tightened at this time)**

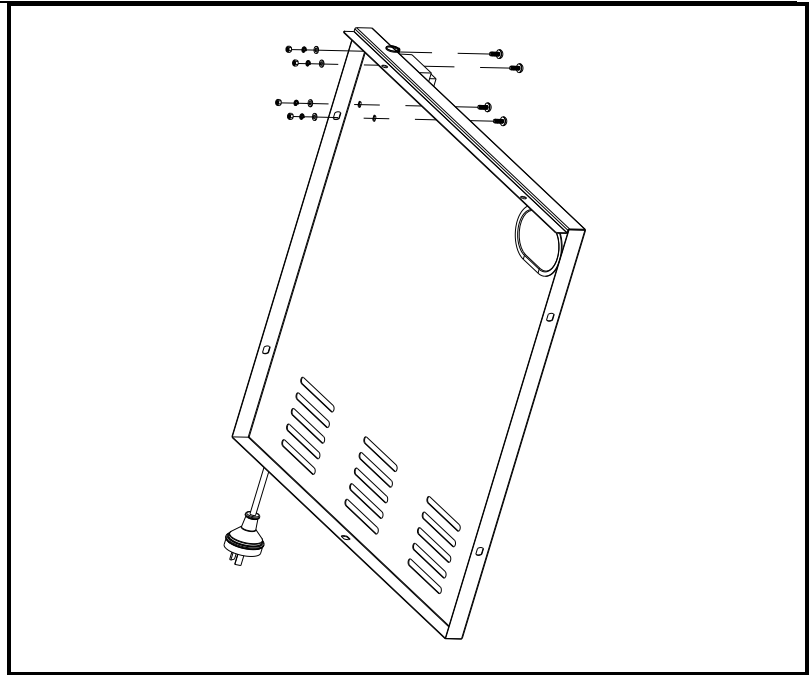

7. Use screw **M6*12**×5 pcs to attach the stand base panel onto the base panel, between the two side panels.

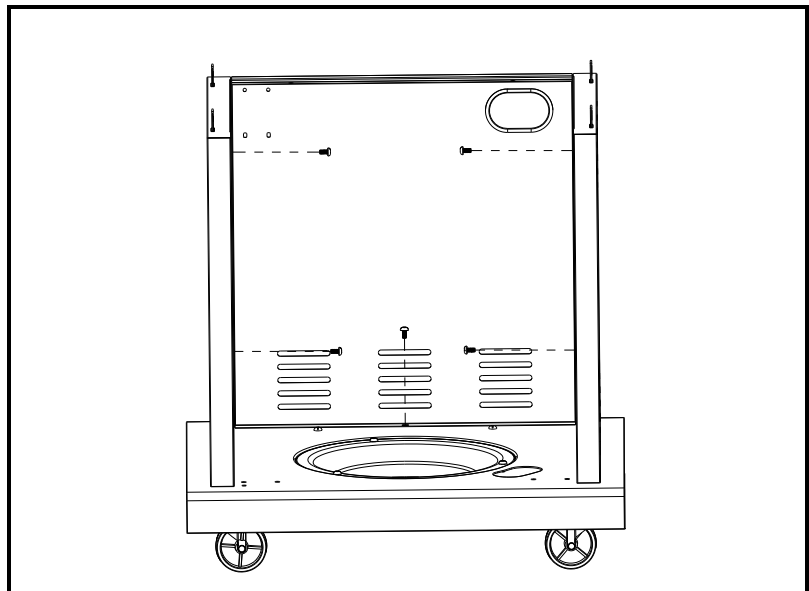

8. Use screw **M4*10**×4 pcs to fix the stand door horizontal beam between the two side panels.

(Note: Please fasten the upper two screws first, and then the lower two screws.)

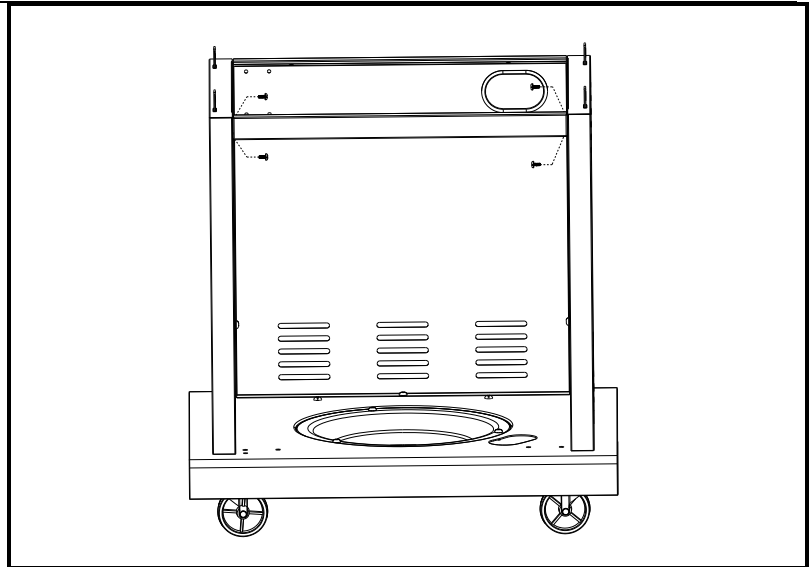

9. Use screw **M4*10**×4 pcs to fix the stand top panel on the top of the two side panels and back panel.

(Note: These screws can be tightened at this time)

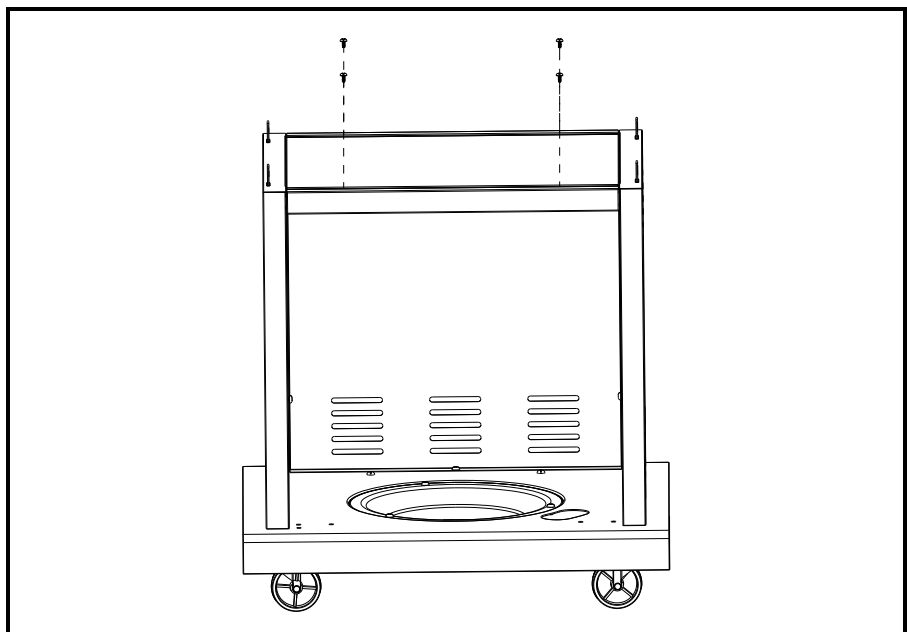

10. Use screw **M5*10**×8 pcs to attach triangle×2 pcs on the bottom of the base panel, leaning against the two side panels.

(Note: These screws can be tightened at this time)

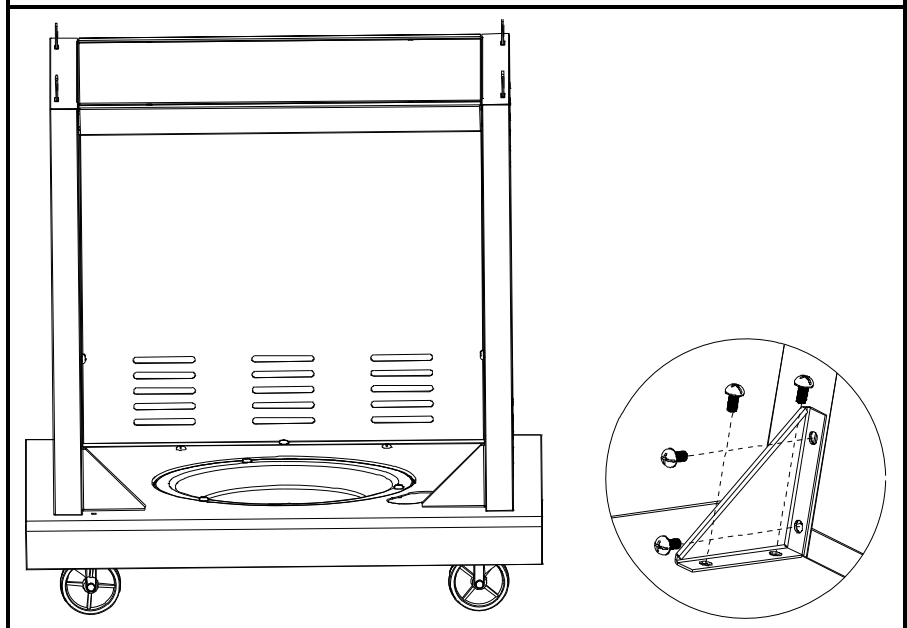

11. First, insert the door lower axis into the hole in the base panel. Next, push down the door upper spring axis and let go of the spring when it is pointed to the hole in the horizontal beam. **(Note: You may need to add 1 or 2 washers 18*6.4*1 on the bottom pin so the door will close evenly)**

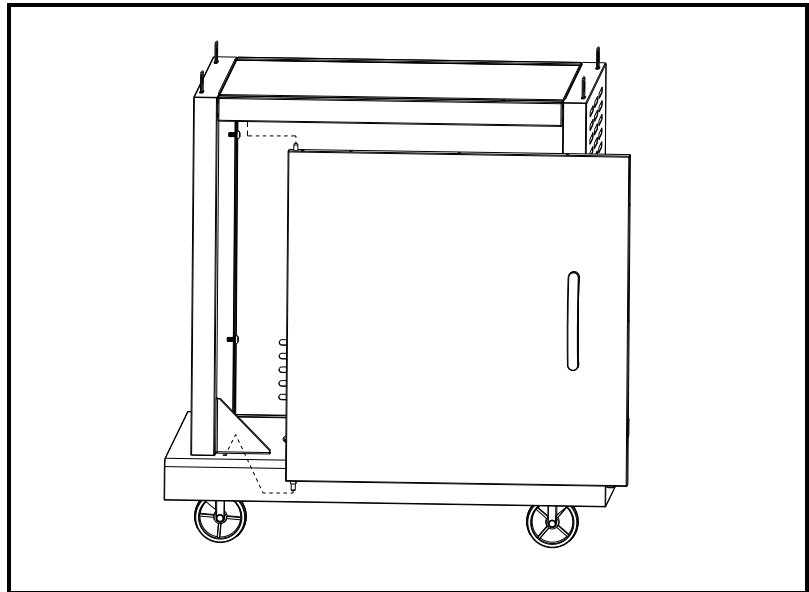

ALMOST FINISHED!!

12. Put the oven assembly on the stand-top panel. Use screw **M6*12**×4 pcs to fasten the oven onto the stand. **(Note: These screws can be tightened at this time)**

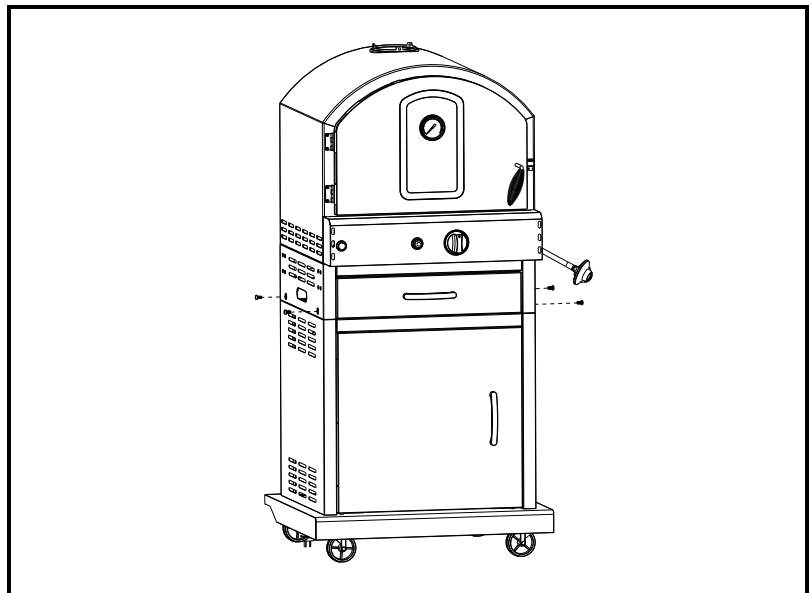

13. Use screw **M5*10**×16 pcs to attach side shelf bracket×4 pcs onto the drawer side panels.

(Note: Arrows face UP)

14. Using one of the screw M5*10 to fix the match holder onto the front bracket of right side shelf.

(This step may be skipped if you do not want or need a “match holder” on your unit)

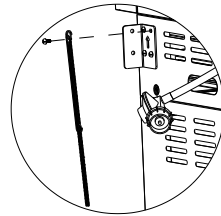
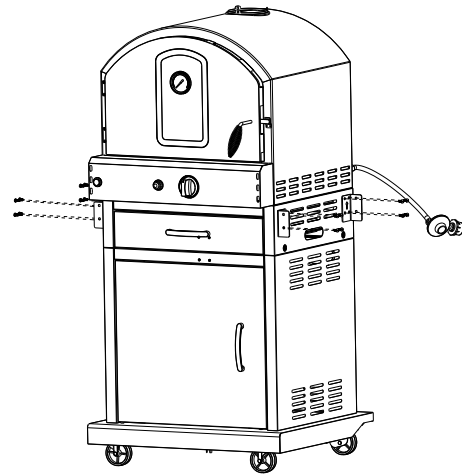

15. Use screw **M6*12**×8 pcs and special nut **TB31-05-03**×8 pcs to hang side shelf×2 pcs onto the four brackets. **(Notes (2): Attach the top set of screws and bolts and hang the shelf from them to assist in attaching the bottom screws and nuts to the shelf. These screws can be tightened at this time)**

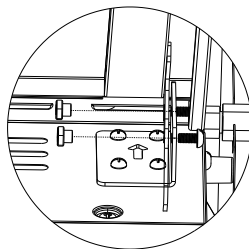
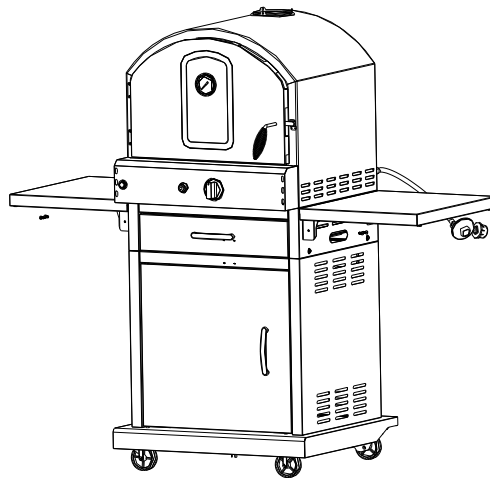

16. Use screw **M4*8**×3 pcs to fix the chimney assembly onto the top of the oven exterior. **(Note: These screws can be tightened at this time)**

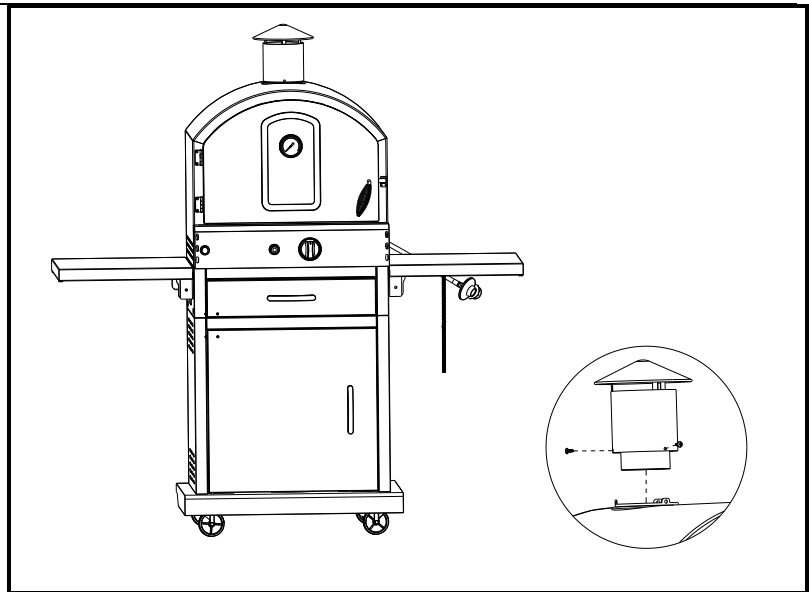

17. Use screw **M5*35**×4 pcs to fix the back heat shield onto the back panel of the oven. The order is: screw back heat shield heat insulation washer flat washer oven back panel.

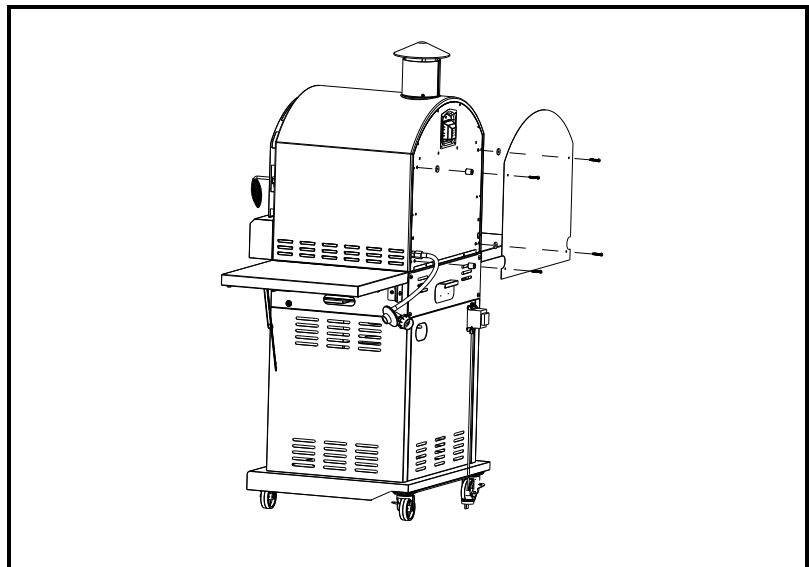

18. Put the following accessories into the oven and close the oven door:

- base grill×1 pc
- pizza stone×1 pc
- cooking grill×2 pcs
- smoker box×1 pc (hang on the cooking grill, exact position is according to the food position inside the oven)
- flame tamer×1 pc

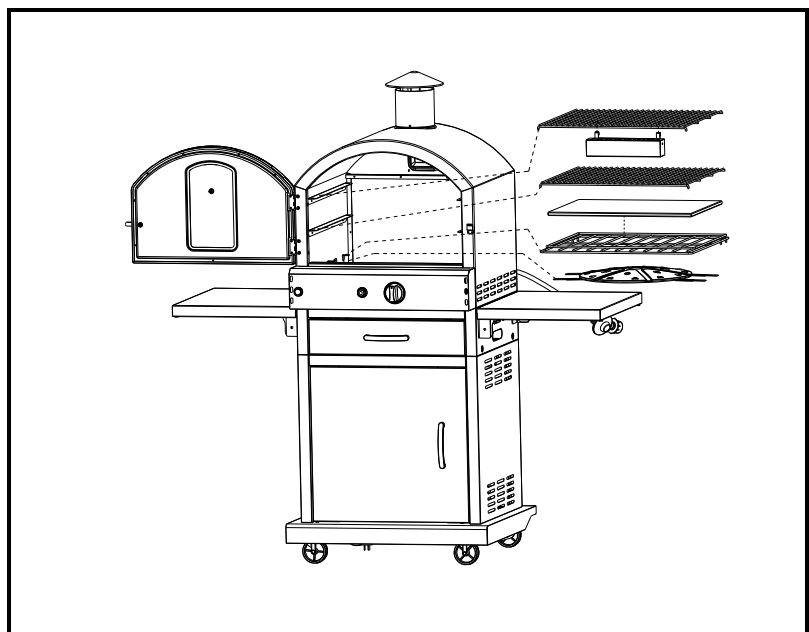

19. Insert the battery into the electronic ignition. Unscrew the button and place battery positive (+) tip facing OUT. Screw button back on.

Your complete oven is now assembled.

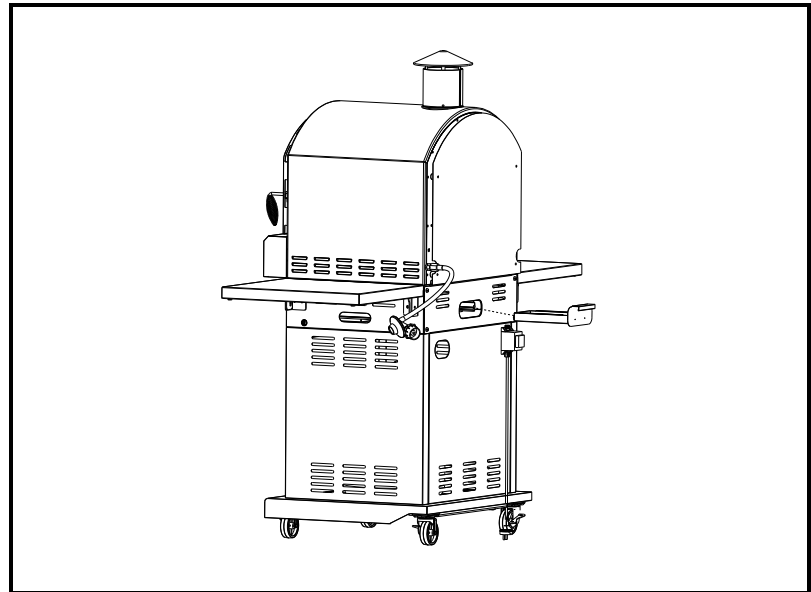

L.P. GAS INSTALLATION

Gas grills that are set to operate with L.P. gas come with a high capacity hose and regulator assembly. (**Note: Only use the pressure regulator and hose assembly supplied with the grill or a replacement pressure regulator and hose assembly specified by the manufacturer**). This assembly is designed to connect directly to a standard 9 kg (20 lb.) L.P. cylinder. L.P. cylinders are not included with the grill. L.P. cylinders can be purchased separately at an independent dealer.

Connecting a Liquid Propane Gas Tank to the Grill:

1. Open the doors of the cabinet. Place a 9 kg (20 lb.) tank with foot ring into the tank tray. See Fig. 4. Make sure the tank valve is in the OFF position.
2. Tighten the retention screw beside the tank tray to secure the tank. See Fig. 5.
3. Check the tank valve to ensure it has proper external mating threads to fit the hose and regulator assembly provided (Type 1 connection per ANSI Z21.89b-2012).
4. Inspect the valve connection port of the regulator assembly. Look for damage or debris. Remove any debris. Inspect hose for damage. Never use damaged or plugged equipment.

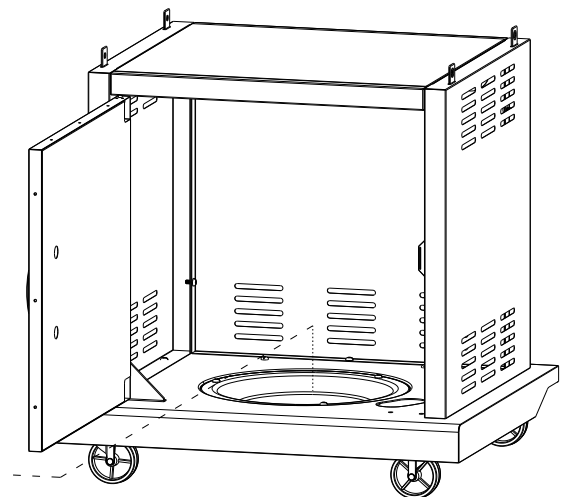

Fig.4

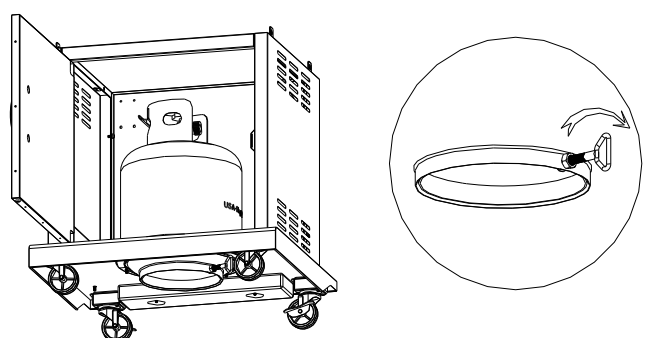
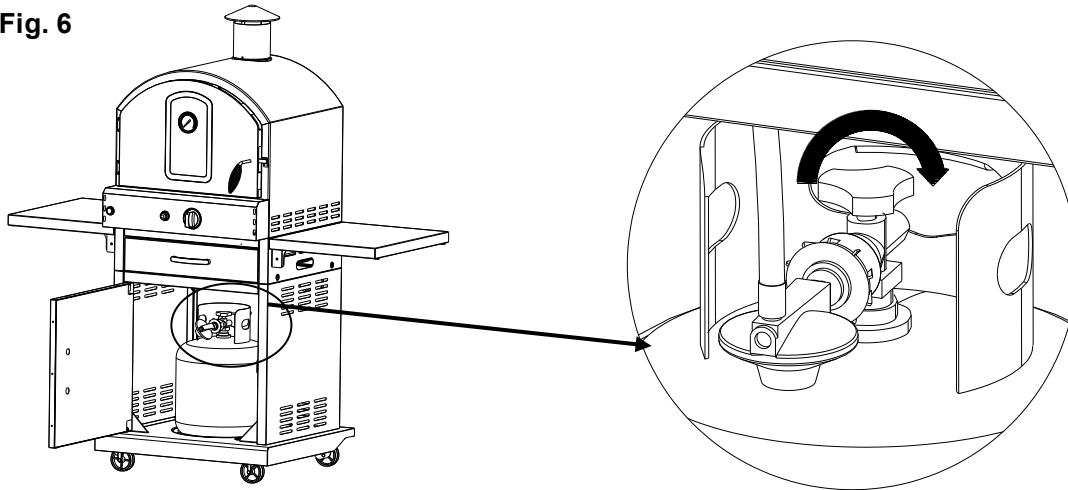

FIG.5

5. Make sure all burner knobs are in the OFF position.

6. Connect the hose and regulator assembly to the tank valve (See Fig. 6). Hand-tighten the quick coupling nut clockwise to a full stop.

Fig. 6



DO NOT use a wrench to tighten because it could damage the quick coupling nut and result in a hazardous condition.

7. Open the tank valve fully (counterclockwise). Use a soapy water solution to check all connections for leaks before attempting to light your grill. See “Pre-Operation Leak Testing” on page 19. If a leak is found, turn the Tank Valve off and do not use your oven until the leak is repaired.

As shown in Fig. 7a, gas tank must be placed vertically. It is unsafe to operate the oven if the gas tank is not vertical as shown in Fig. 7b.

Fig. 7a

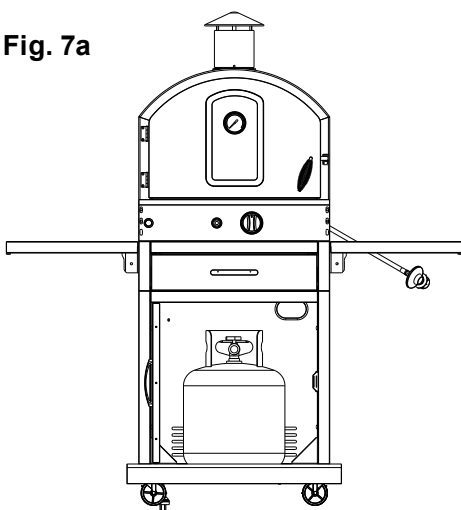
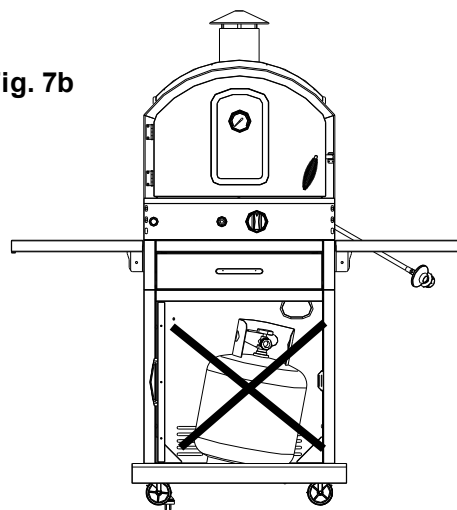

Fig. 7b





WARNING: The Type I connective coupling (see Fig. 7) supplied with your oven must not be replaced with a different type of grill/tank connection system. Removal will result in loss of warranty, gas leakage, fire and severe bodily harm.

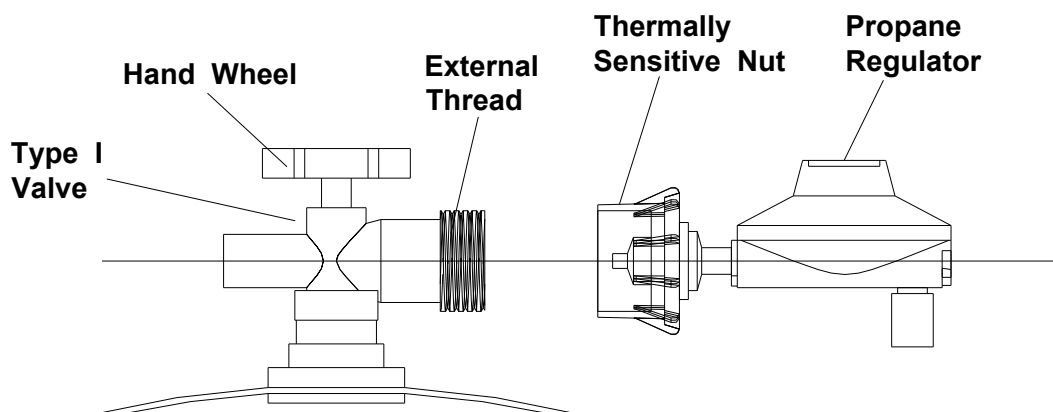
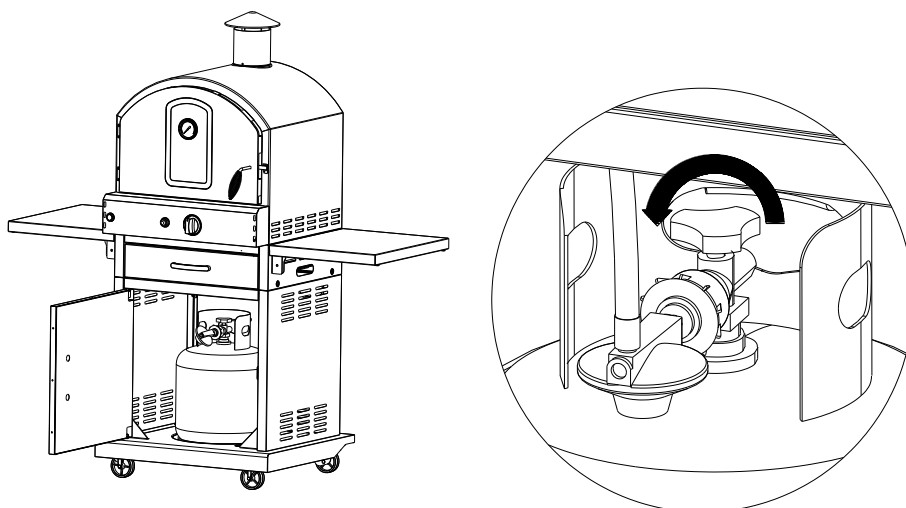

FIG 7

Disconnecting a Liquid Propane Gas (LP Gas) Tank from Your Oven:

1. Turn the burner knobs and LP gas tank valve to the full OFF position. (Turn clockwise to close.)
2. Detach the hose and regulator assembly from the LP gas tank valve by turning the quick coupling nut counterclockwise.



CAUTION: When the appliance is not in use, the gas must be turned off at the supply tank.

L.P. TANK INFORMATION

Never use a dented or rusted L.P. tank or cylinder with a damaged valve.

L.P. cylinders are equipped with an O.P.D. (Overfilling Prevention Device). The device shuts off the flow of gas to a cylinder after 80% capacity is reached. This limits the potential for release of gas when the cylinder is heated, averting a fire or possible injury.

The L.P. cylinder must have a shut-off valve terminating in an L.P. gas supply cylinder outlet specified, as applicable, for connection No. 510 in the standard for compressed gas cylinder valve outlet and inlet connection ANSI/CGA-V-1. Cylinders must not be stored in a building, garage, or any other enclosed area. (The L.P. cylinder must have an overfill protection device and a collar to protect the cylinder valve.)

The L.P. gas supply cylinder must be constructed and marked in accordance with the specifications for L.P. gas cylinders of the U.S. Department of Transportation (DOT) or the National Standard of Canada, CAN/CAS-B339, "Cylinders, Spheres and Tubes for the Transportation of Dangerous Goods and Commission."

L.P. TANK USE

- **When turning the L.P. tank on, make sure to open the valve SLOWLY two (2) complete turns to ensure proper gas flow. Most gas tanks now come equipped with a leak detector mechanism internal to the tank. When gas is allowed to escape rapidly, it shuts off the gas supply. Opening the valve rapidly may simulate a gas leak, causing the safety device to activate, restricting gas flow and causing low flames. Opening the valve slowly will ensure this safety feature is not falsely triggered.**
- When not in use, gas supply cylinder valve is to be in the "OFF" position.
- The tank supply system must be stored upright to allow for vapor withdrawal.
- The regulator and hose assembly must be inspected before each use of the oven. If there is excessive abrasion or wear or if the hose is cut, it must be replaced prior to the grill being used again.
- Cylinders must be stored outdoors out of the reach of children and must not be stored in a building, garage or any other enclosed area.
- Only a qualified gas supplier should refill the L.P. tank.
- Place dust cap on cylinder valve outlet whenever the cylinder is not in use. Only install the type of dust cap on the cylinder valve outlet that is provided with the cylinder valve. Other types of caps or plugs may result in leakage of propane.



WARNING

DO NOT store a spare L.P. gas cylinder under or near the oven. Never fill the cylinder beyond 80% full.

If this information is not followed exactly, a fire causing death or serious injury may occur.

PRE-OPERATION LEAK TESTING

Although all gas connections on the oven are leak tested prior to shipment, a complete gas tightness check must be performed at the installation site due to possible shifting during shipment, installation or excessive pressure unknowingly being applied to the unit. Periodically check the whole system for leaks and immediately check the system if the smell of gas is detected.

1. Do not smoke while leak testing.
2. Extinguish all open flames.
3. Never leak test with an open flame.
4. Mix a solution of equal parts mild detergent or liquid soap and water.
5. Turn off the burner control knobs.
6. Turn the top knob of the fuel supply cylinder counterclockwise two (2) rotations to open.
7. Apply the soap solution to connections of the fuel supply assembly. If no soap bubbles appear, there is no gas leak. If bubbles form at the connections, a leak is detected. If a leak is detected, immediately turn off the gas supply, tighten any leaking fittings, turn gas on, and repeat steps 1-3.
8. Turn off the knob on the fuel supply cylinder.
9. Turn on the burner control knobs for a moment to release the pressure in the hose, then turn the control knobs back off.
10. Wash off soapy solution with cold water and towel dry.

Check all gas supply fittings before each use and each time the gas supply cylinder is connected to the regulator. Have a qualified service technician leak test the oven any time a part of the gas system is replaced.

It is also recommended that you perform a leak test at least once a year whether or not the L.P. gas supply cylinder has been disconnected.



WARNING When leak testing this appliance, make sure to test and tighten all loose connections. A slight leak in the system can result in a low flame or hazardous condition. Most L.P. gas tanks now come equipped with a leak detector mechanism internal to the tank. When gas is allowed to escape rapidly, it shuts off the gas supply. A leak may significantly reduce the gas flow, making the oven difficult to light or causing low flames.

If you cannot stop a gas leak, turn off the gas supply and call your local gas company. If necessary, replace the faulty part with the manufacturer's recommended replacement part. A slight leak could cause a fire.



WARNING Do not use the oven in garages, breezeways, sheds or any enclosed area.

Never operate the oven in enclosed areas as this could lead to a carbon monoxide buildup, which could result in injury or death. Place the oven on a level surface. Avoid moving the oven while it is in operation.

NOTE: The oven will operate best if it is not facing directly into the wind

PREPARATION FOR NG CONVERSION:

Before beginning conversion, make sure all parts are present. Compare parts with package contents. If any part is missing or damaged, do not attempt to convert. Contact customer service for replacement parts.

1. Turn off gas supply, and then remove cap on gas supply side.
2. Recommended: Install a shut-off valve on gas supply side before installing the socket.
3. Socket should be installed by an authorized technician in accordance with the national fuel gas code (NFPA 54/ANSI223.1).
4. Before inserting plug, turn on gas supply and leak test all connections including the stem of the shut-off valve and the opening of the socket. For best results, use an ammonia-free soap and water solution.

NATURAL GAS INSTRUCTION:

1. To connect, push back socket sleeve (Fig. 1).
2. Insert plug and release sleeve (Fig. 2).
3. Push plug until sleeve snaps forward (Fig. 3). (Gas will flow automatically. Failure to connect plug properly to socket will inhibit gas flow to the appliance.)
4. Test connection with ammonia-free soap and water solution.

To disconnect

1. Pull sleeve back. Pull plug out of socket. (Gas is automatically shut off.)
2. Close shut-off valve and replace dust caps on socket and plug.

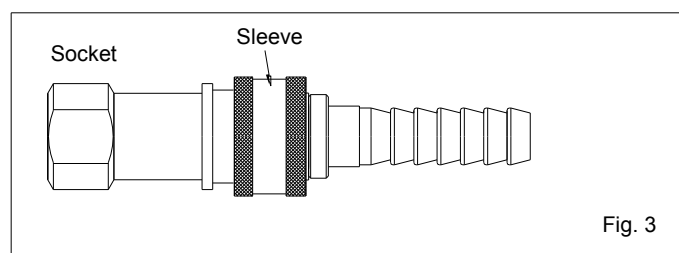
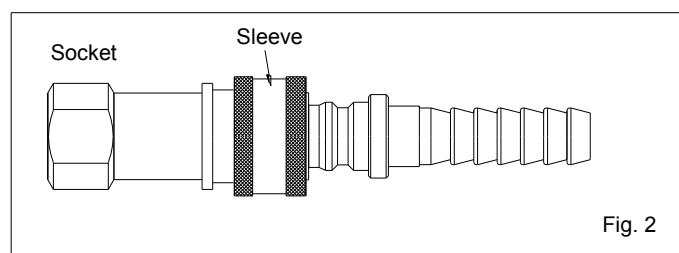
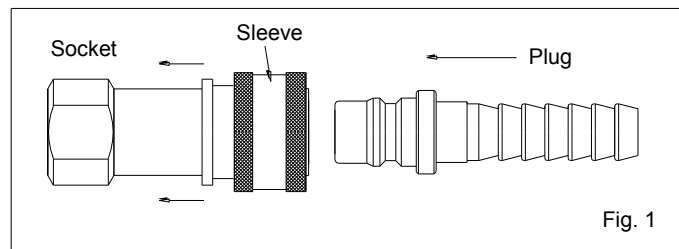



WARNING:

Place the oven on a flat, level surface.

Before the conversion, make sure all control knobs are in the OFF position, LP tank valve is closed, and tank is disconnected from regulator and removed from grill.

NG CONVERSION INSTRUCTION:

Before the conversion, make sure all control knobs are in the OFF position, LP tank valve is closed, and tank is disconnected from regulator and removed from oven.

Before the conversion, make sure all control knobs are in the OFF position, LP tank valve is closed, and tank is disconnected from regulator and removed from oven. Next, open the door and remove the two cooking grids, smoker box, pizza stone, base oven and flame tamer.

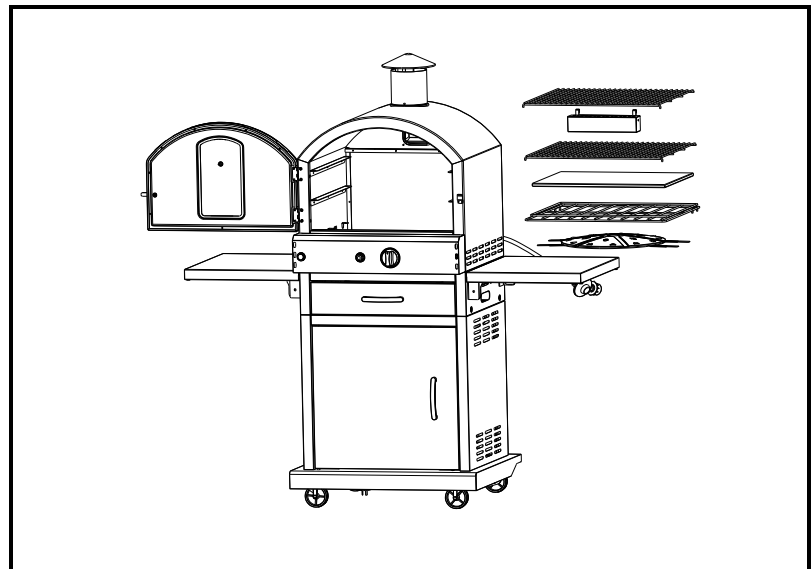

Loosen the screws that are used to fasten the burner (see picture at right). Use a 10x12 mm Wrench to remove the thermocouple (right side of the burner) out from the burner. Next, pull out the ignition wire from the electronic igniter. Finally, take out the whole burner.

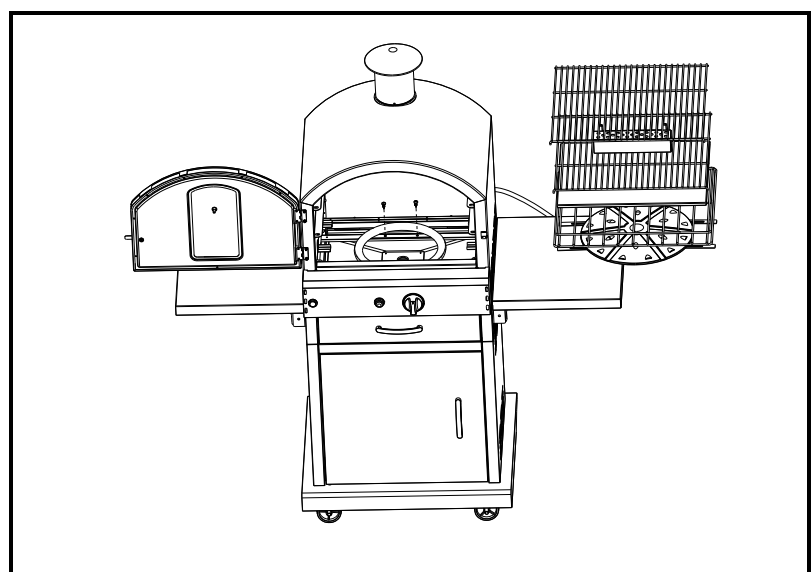

Use a screwdriver to loosen the screw that is used to fasten the burner cover. Turn the burner cover until the hole marked “NG” overlaps with the fixing hole on the burner. Put the screw back into the holes and tighten again.

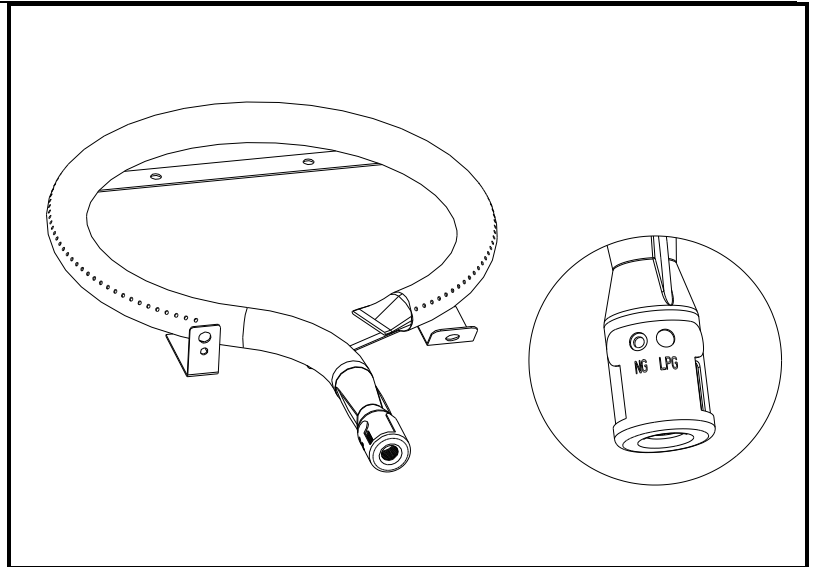

Use orifice removal tool to remove the ϕ 1.31 LP orifice from the oven. And then use the same tool to fix the ϕ 1.98 NG orifice back to the position.

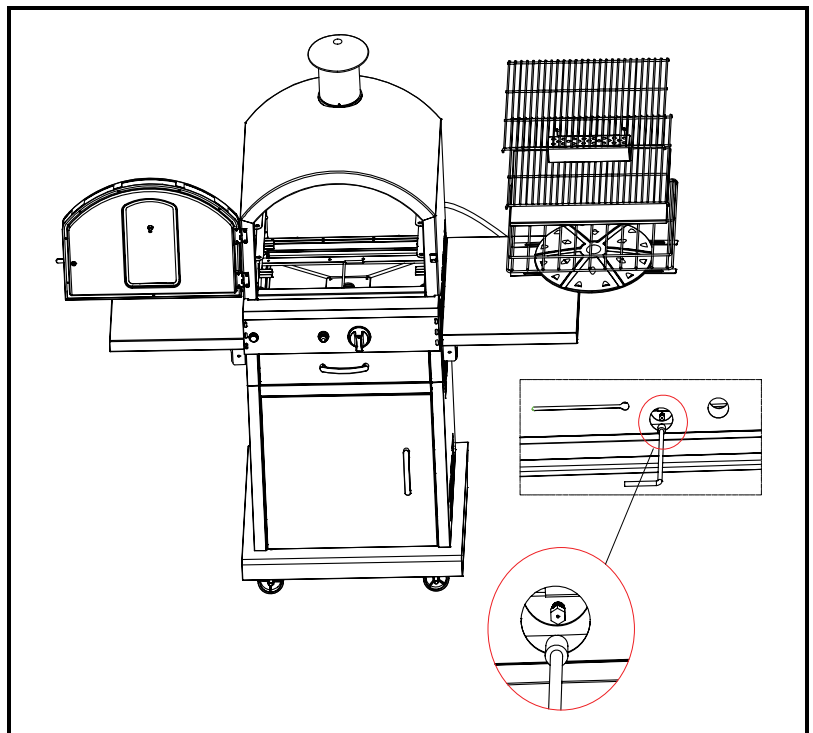

Put the burner back into the oven and insert the ignition wire into the original position. Use the 10x12 mm spanner to fix the thermocouple back into the oven again. Finally, fasten the burner with the original screws.

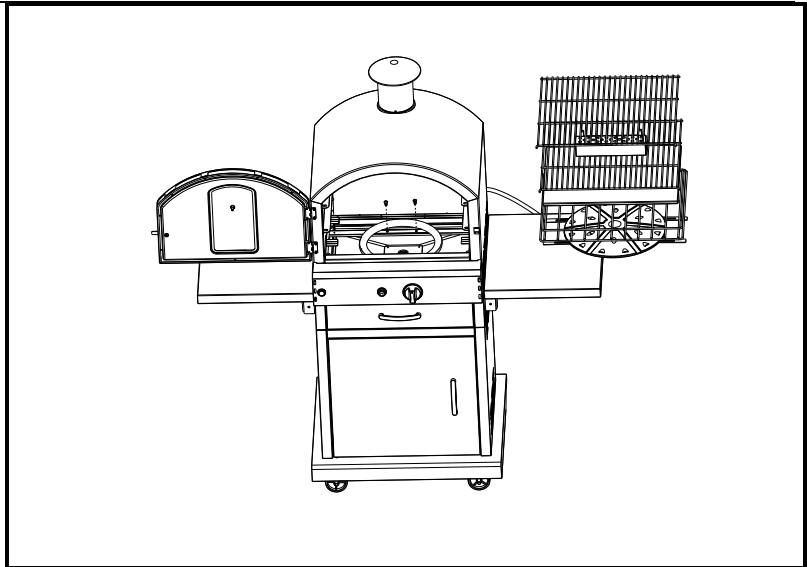

Put back the two cooking grids, smoker box, pizza stone and base grill into the right position.

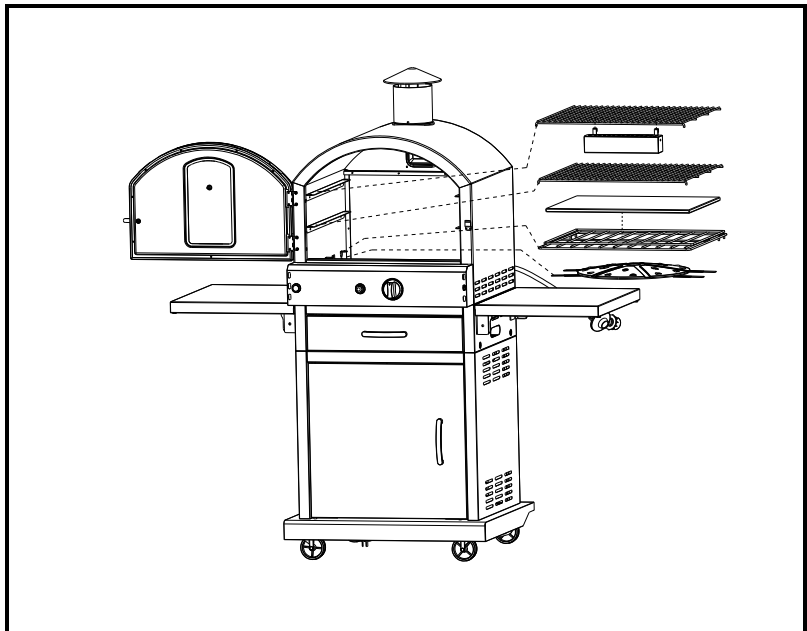

Use the 17X19 mm wrench to remove the regulator and then put on the NG hose. Fasten the hose using 17X19 mm wrench.

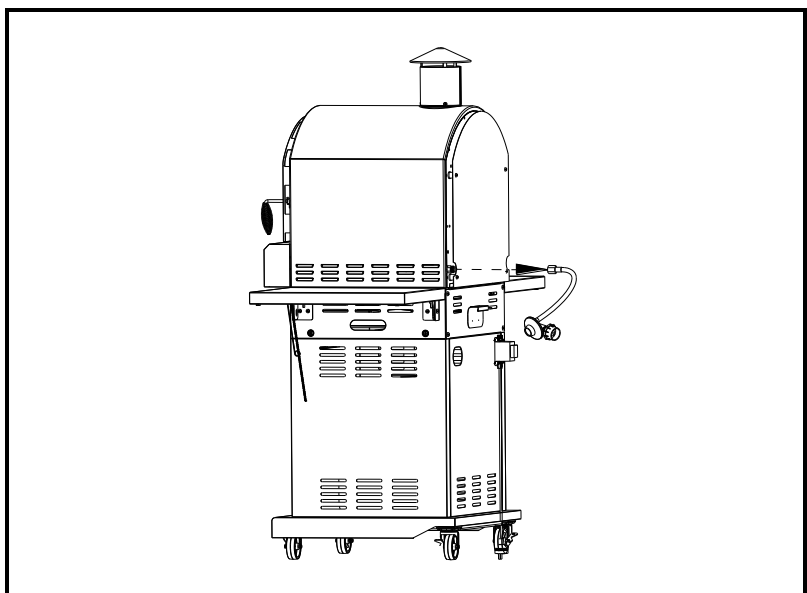

Use the screw driver to put the conversion screw into the knob.

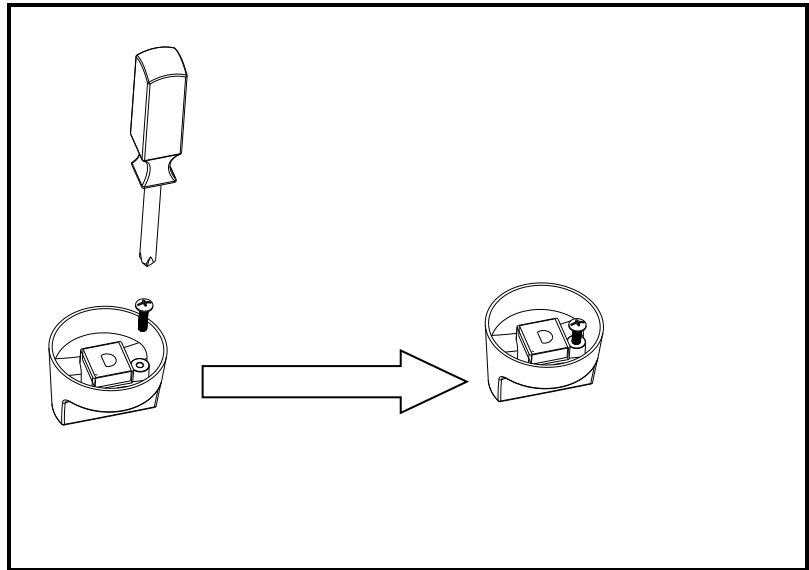

When converting to natural gas, please be aware that the low heat setting of the main burners and searing burner is “NG LOW,” as shown on the control panel. “LP LOW” setting is not applied when converting to natural gas.

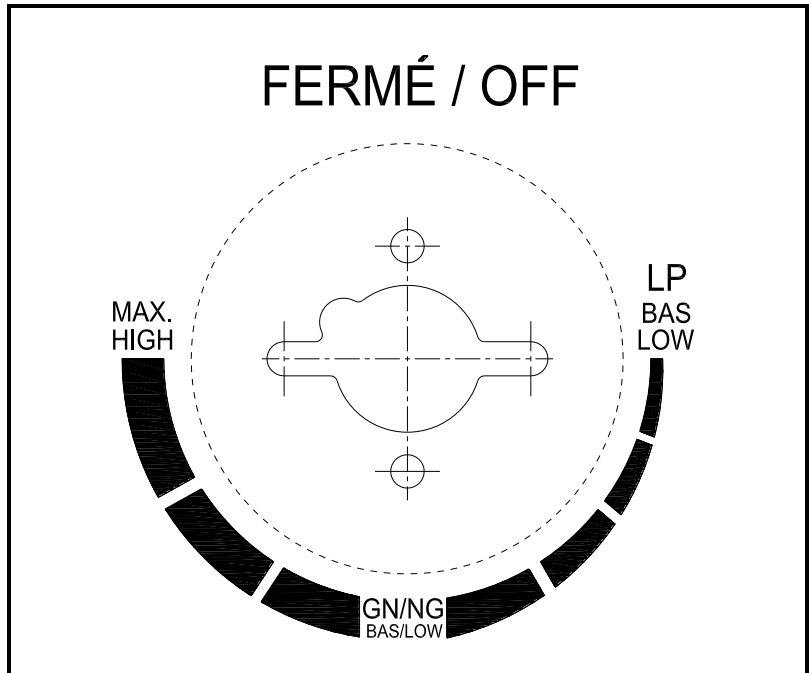

WARNING: Please remember this is an outdoor gas oven. Many areas of the grill generate extreme heat. We have taken every precaution to protect you from the contact areas. However, it is impossible to isolate all high-temperature areas. Therefore, use good judgment and a certain degree of caution when cooking on this product. We suggest a covered, protected hand during operation of the oven. Do not move the oven when it is in operation or hot to the touch. Wait until the unit is turned off and properly cooled down before moving it. Failure to follow this warning could result in personal injury.



IMPORTANT:

After your outdoor oven is converted to natural gas, the working pressure for natural gas is 7-inch water column (WC). Gas pressure is affected by gas line size and the length of gas line run from house. Follow the recommendations in the chart below.

From House to Oven	
Distance	Tubing Size
Up to 25 ft.	3/8 in. DIA
26 – 50 ft.	1/2 in. DIA
51 – 100 ft.	2/3 in. of run 3/4 in. 1/3 in. of run 1/2 in.
Over 101 ft.	3/4 in. DIA

Burner	LP Gas	Natural Gas
Main Burner	20,000 BTU / Hr	20,000 BTU / Hr



CAUTION:

If low flames or burner problems are observed after converting from LPG to NG, the natural gas lines may not be large enough. Refer to the “From House to Oven” chart above for natural gas supply line specifications. Please contact a plumber to assure proper pressure at 7-inch water column.

DO NOT RETURN YOUR GRILL TO THE STORE.

Never attach an unregulated gas line to the appliance. Connection to an unregulated gas line can cause excessive heat or fire.

Verify the type of gas supply to be used, either Natural Gas (N.G.) or Liquid Propane (L.P.), and make sure the serial plate agrees with that of the supply. Conversion kits are available separately for an additional cost, which will enable you to convert your oven from L.P. to N.G. or to convert your oven from N.G. to L.P. Please see your local dealer for more information.

Always have a qualified service technician perform difficult conversions or modifications.

For natural gas installations, an installer must supply a gas shutoff valve that is easily accessible to the oven. All installer supplied parts must conform to local codes, or in the absence of local codes, with the National Electrical Code, ANSI/NFPA 70- 2002, and the National Fuel Gas Code, NFPA 54-2002/ANSI Z223.1-2002.

All pipe sealants must be an approved type and resistant to the actions of L.P. gases. Never use pipe sealant on flare fittings. All gas connections should be made by a competent qualified service technician and in accordance with local codes and ordinances. In the absence of local codes, the installation must comply with the National Fuel Gas Code, NFPA 54-2002/ANSI Z223.1-2002. Gas conversion kits may be purchased separately. **When ordering gas conversion kits, have the model number and the type of gas (N.G. or L.P.) used for your oven on hand.**

This oven must be isolated from the gas supply piping system by closing its individual manual shut-off valve during any pressure testing of the gas supply piping system at test pressures equal to or less than 1/2 PSIG (3.5 kPa).

The installation of this oven must conform with local codes, or in the absence of local codes, with National Fuel Code, NFPA 54-2002/ANSI Z223.1a-2002.

Installation in Canada must be in accordance with the Standard CSA B149.1 or B149.2 (installation code for gas burning appliances and equipment) and local codes.

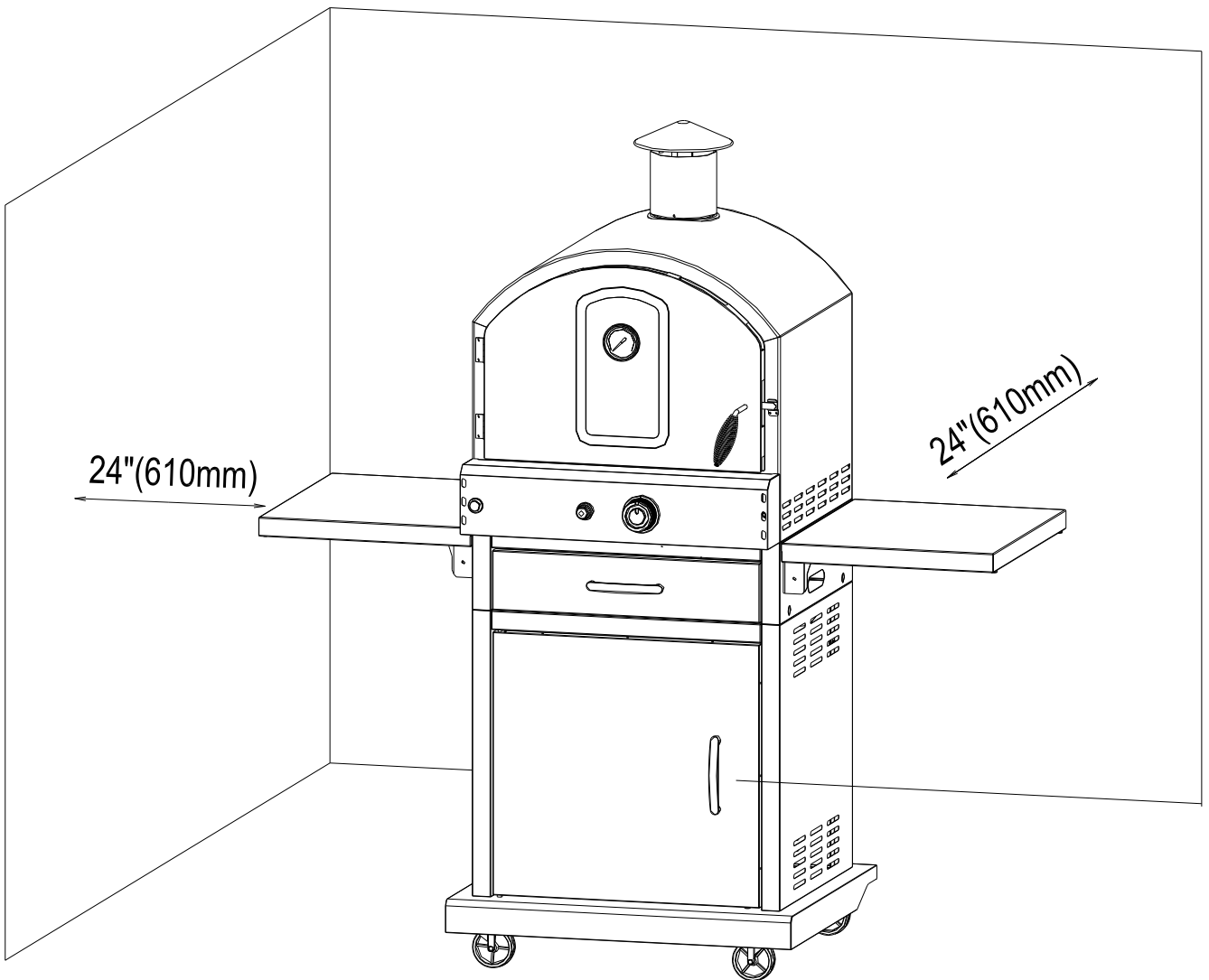

Clearance to combustible construction: A minimum of 61 cm (24 inches) from the sides and back must be maintained from the gas grill above and below the cooking surface to adjacent vertical combustible construction.

Storage of an outdoor gas cooking appliance indoor is permissible only if the cylinder is disconnected and removed from the appliance.

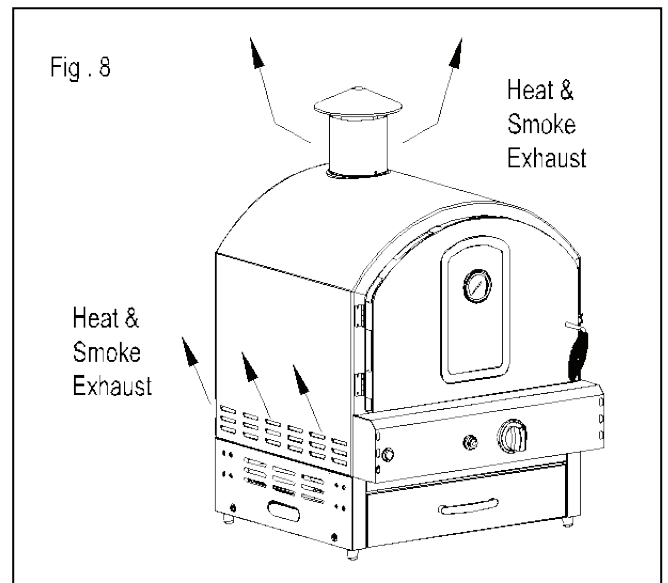



WARNING Heat and smoke exhaust out of the chimney and the ventilation holes on the bottom of two oven side panels (See Fig. 8). Make sure to keep anything that could be damaged by heat or smoke away from the heat and smoke exhaust holes.

GENERAL RULES

Do not leave the oven unattended while cooking!

1. Make sure the oven has been leak-tested and is properly located.
2. Light the grill burners using the instructions provided in this manual.
3. Turn the control knobs to desired temperature - High or Low - and preheat the grill for 10 minutes before cooking.
4. Adjust heat settings to meet your cooking needs for desired results.
5. Allow grill to cool down, wipe off any splatters or grease and clean the drip tray as needed.
6. Do not put a cover on the grill while it is still hot as it could start a fire.

Do not attempt to “light” the grill if the odor of gas is present!!

BEFORE AND AFTER LIGHTING

1. Ensure your oven is located on a level surface.
2. Keep the gas oven area clean and free from combustible materials, gasoline, and other flammable vapors and liquids.
3. Ensure nothing is obstructing the flow of combustion and ventilation air.
4. Ensure the ventilation of the cylinder enclosure is free and clear of debris.
5. Visually check burner flames.



WARNING Check the gas supply line for cuts, wear or abrasion. Always keep your face and body as far away from the oven as possible when lighting.

Operating Instructions

OVEN BURNER LIGHTING

Warning: Do not lean over oven when lighting.
Turn off LP supply at cylinder when appliance is not in use.

Main Burner Lighting Illustration:

1. Check that the control knobs are in the OFF position.
2. Open valve at tank fully by turning counterclockwise.
3. The door must always be in the OPEN position for lighting;
4. Push the Electronic Ignition down 3 to 4 seconds while turning the control knob to the HIGH position. The burner should ignite.

If ignition does not take place within 5 seconds, immediately turn the control knob to the OFF position. Wait 5 minutes and repeat step 4 above or refer to match lighting instructions in manual.

If by chance the electronic igniter does not light the burner, the burner may be lit with a match attached to the match extender, located on the inside of the cabinet door.

Remove the base grate and pizza stone. Keep your face as far away from the burner surface as possible and pass the match extender to the ports of the main burner tubes. Position the match near the burner ports and push and turn the control knob counterclockwise to the "HIGH" position. After the burner has lit, turn the knob to the "LP LOW" position and carefully place the flame tamers and grates back in position. Then turn the control knob to the desired setting.

NOTE: If the oven will not light after several attempts see the Troubleshooting section of this manual. Turn the control knobs to the OFF position when not in use.

FERMÉ / OFF

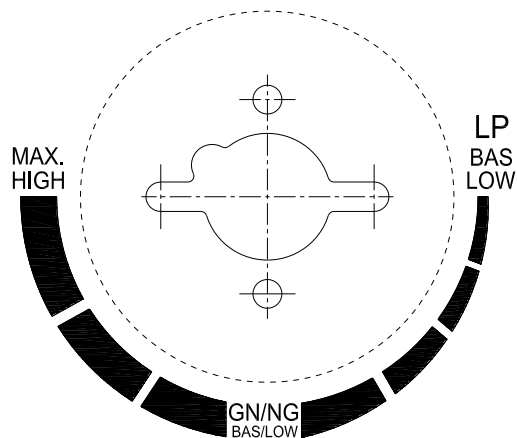

Main Burner Control Knob

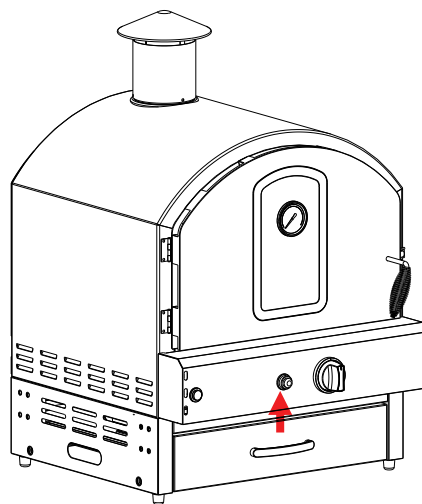

Keep any electrical supply cords and the fuel supply away from any heated surfaces.

USING THE GRILL LIGHT

Light Operation Instruction

1. Make sure the light's power switch on the control panel is in the "OFF" position.
2. Connect power plug to properly grounded outlet.
3. Turn the light's power switch to "ON."



WARNING

Keep any electrical supply cord away from any heated surface.

IMPAIRED VENTILATION OF HOT AIR FROM OVEN - In order for the burners to function properly, hot air created by the burners must have a way to escape. The burners may become deprived of oxygen, causing them to backfire, especially if the burner output is set at HIGH. If this occurs repeatedly, the burners may crack. This is the reason your oven was designed with ventilation louvers. These design features give the hot air an escape route. Accordingly, never operate your oven with very little or no open space at the cooking surface (the cooking grids provide sufficient space). Also, never cover the ventilation louvers with foil or other materials that prevent air flow. Specifically, do not cover the entire surface with foil, a large pan, etc.

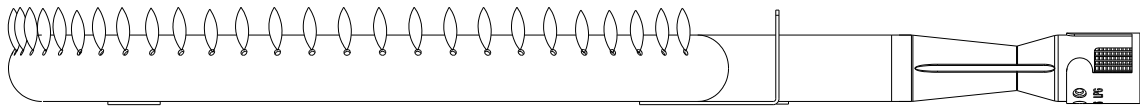

Normal: Soft blue flames

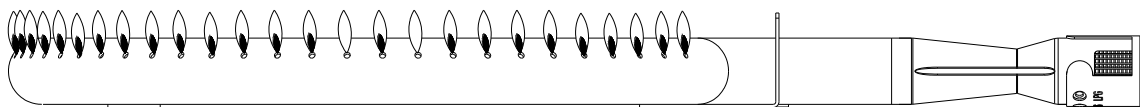

Out of Adjustment: Hard blue flames-too much air

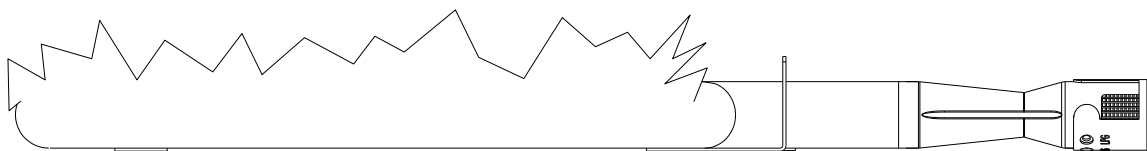

Poor Combustion: wavy, yellow flames-too little air

Care & Maintenance

GENERAL MAINTENANCE

- Keep outdoor cooking gas appliance area clear and free from combustible materials, gasoline and other flammable vapors and liquids.
- Do not obstruct the flow of combustion and ventilation air.
- Keep the ventilation openings of the cylinder enclosure free and clear from debris.
- Visually check the burners.

GENERAL CLEANING

IMPORTANT: Before cleaning, make sure all controls are off and the oven is cool. Always follow label instructions on cleaning products.

For routine cleaning, wash with soap and water using a soft cloth or sponge. Rinse with clean water and dry at once with a soft, lint-free cloth to avoid spots and streaks.

To avoid scratching the surface, do not use steel wool to clean the oven.

Use a grill cover to protect finish from weather.

DRIP TRAY

The drip tray should be cleaned periodically to prevent heavy buildup of debris.

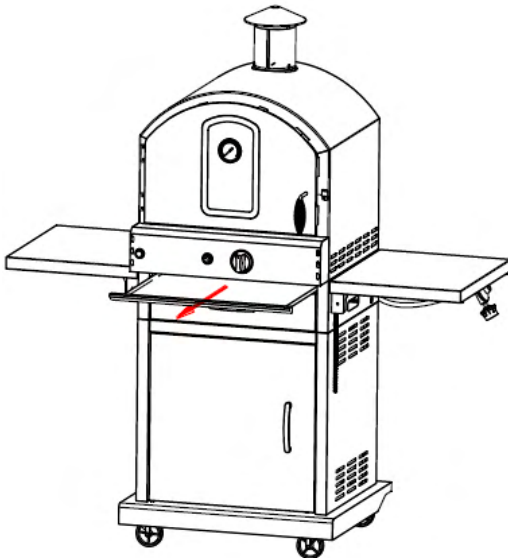

NOTE: Allow the drip tray to cool before attempting to clean.

Important: Do not leave the oven outside during inclement weather unless it is covered. Rain water can collect inside of the oven, the oven cart or the drip tray if left uncovered. If the drip tray is not cleaned after use and the oven is left uncovered, the drip tray will fill with water causing grease and water to spill into the oven cart. The drip tray should be cleaned periodically according to the amount of usage.

COOKING GRATES

The cooking grates can be cleaned immediately after cooking is completed and after turning off the oven. Wear a barbecue mitt and scrub the cooking grates with a damp cloth. If the oven is allowed to cool down, cleaning the grates will be easier if removed from the oven and cleaned with a mild detergent.

STAINLESS STEEL

After initial usage, areas of the oven may discolor from the intense heat given off by the burners.

This is normal. Purchase a mild stainless steel cleaner and rub in the direction of the grain of the metal. Specks of grease can gather on the surface of the stainless steel and bake on to the surface and give a worn appearance. For removal, use a non-abrasive oven cleaner in conjunction with a stainless cleaner.

NOTE: Always scrub in the direction of the grain.

GRILL LIGHT

Bulb Replacement

IMPORTANT SAFETY INSTRUCTIONS

Lighted lamp is HOT:



WARNING -TO REDUCE THE RISK OF FIRE, ELECTRIC SHOCK, EXPOSURE TO EXCESSIVE UV RADIATION, OR INJURY TO PERSONS.

1. Turn off/unplug and allow to cool before replacing bulb (lamp).
2. Bulb (lamp) gets HOT quickly! Only contact switch/plug when turning on.
3. Do not touch hot lens, guard, or enclosure.
4. Do not remain in light if skin feels warm.
5. Do not look directly at lighted lamp.
6. Keep lamp away from materials that may burn.
7. Use only with a 10-watt or smaller bulb (lamp).
8. Do not touch the bulb (lamp) at any time. Use a soft cloth. Oil from skin may damage bulb (lamp).
9. Do not operate the portable luminaries with a missing or damaged guard, lamp containment barrier, or UV filter.

Definitions:

(+) Guard – Guard is a portion of portable luminaries unit that prevents inadvertent contact with the bulb. It may be integrated with the UV filter or lamp containment barrier or as part of an enclosure or shade.

(+) Lamp containment barrier – lamp containment barrier is a portion of a portable luminaries unit that encloses the bulb.

(+) UV filter – UV filter is a portion of a portable luminaries unit that limits ultraviolet (UV) emissions.

1. Turn off/unplug and allow to cool before replacing bulb (lamp). Next, open the door and remove the two cooking grills, smoker box, pizza stone, base grill and flame tamer.

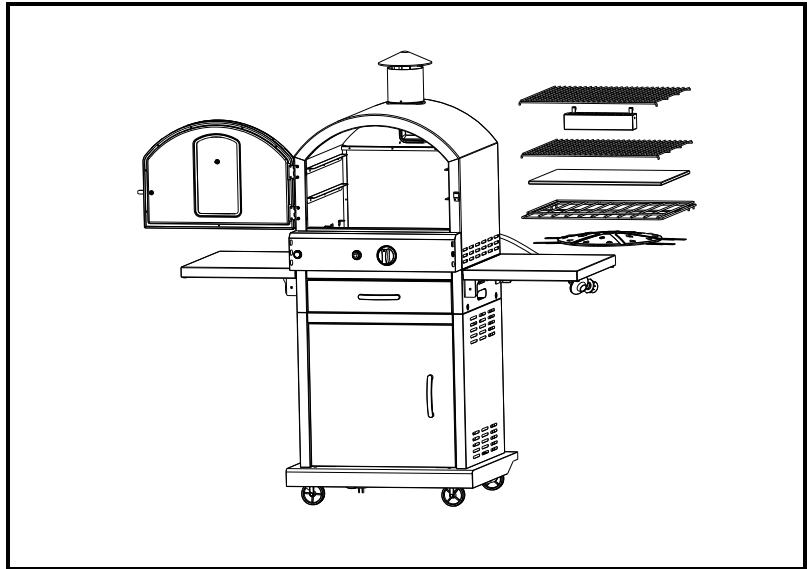

2. Use screw driver to loosen M5*35 screw * 4 pcs that fix the heat shield. And then remove the heat shield.

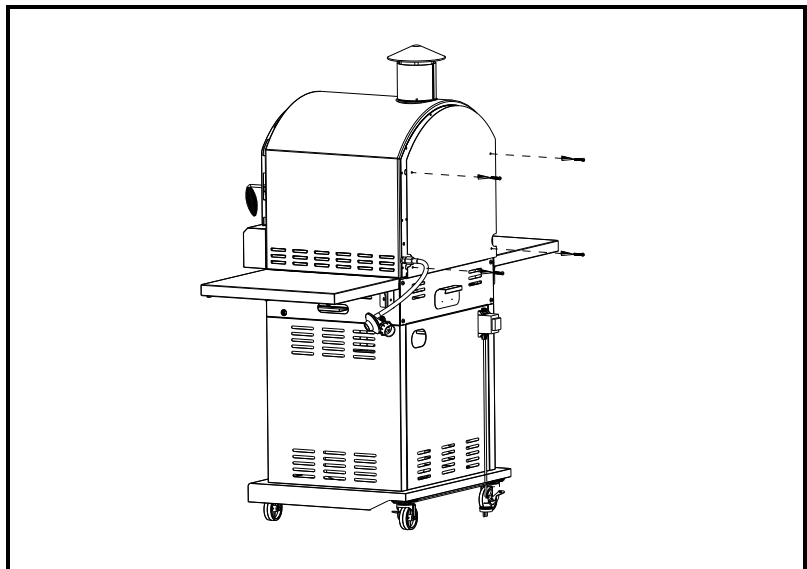

3. Use screw driver to loosen the screw that fix the light assy.

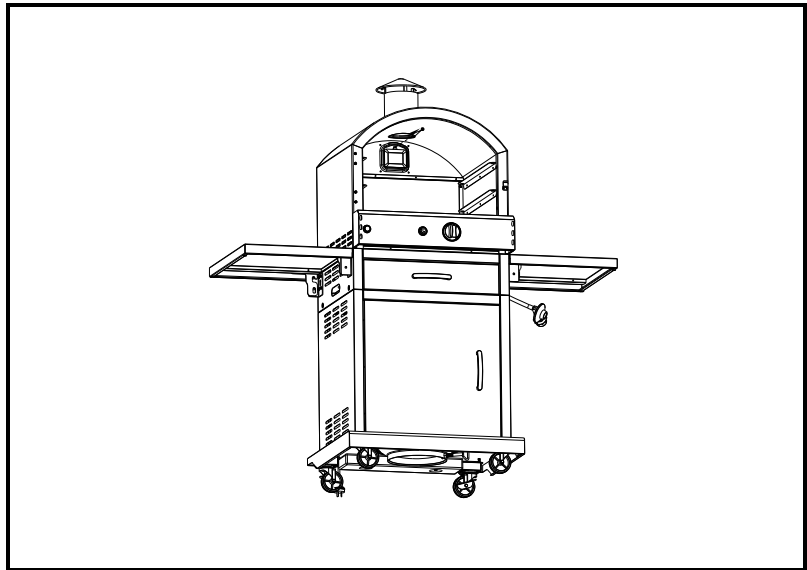

4. Use one hand to hold the metal back part of the light and one handle to hold the front glass cover and then take them apart. Then you can replace the bulb.

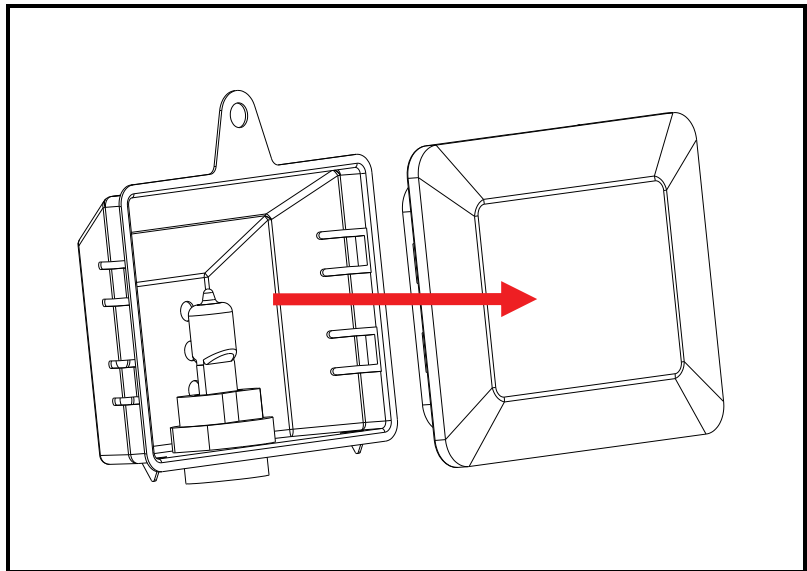

5. After replacement, use one hand to hold the metal back part of the light and one handle to hold the front glass cover and then clip them together in the right position.

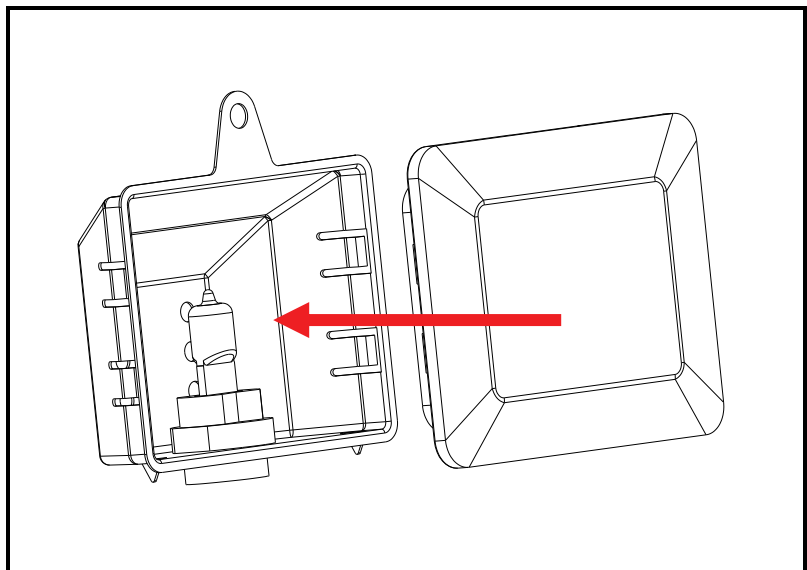

6. Use M4*10 screw to fix the light assy. on to the back panel of the oven.

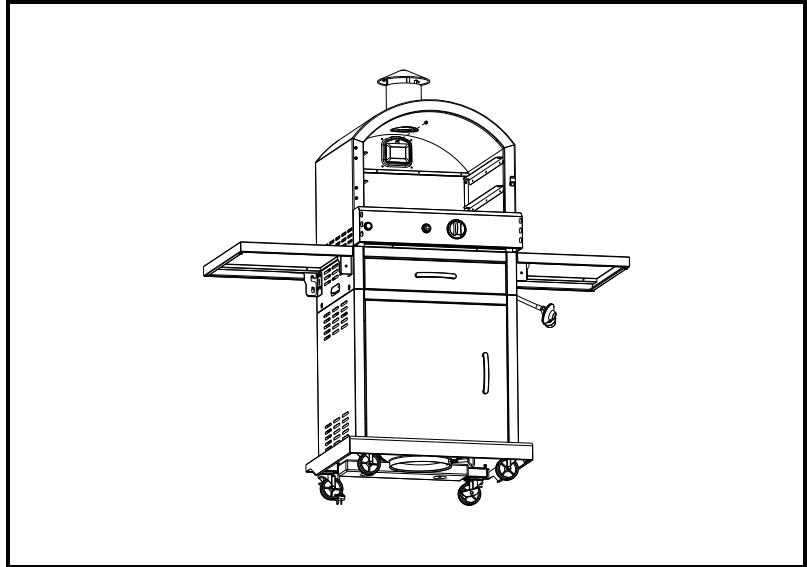

7. Use screw M5*35× 4 pcs to fix the back heat shield onto the back panel of the oven. The order is: screw back heat shield heat insulation washer flat washer oven back panel.

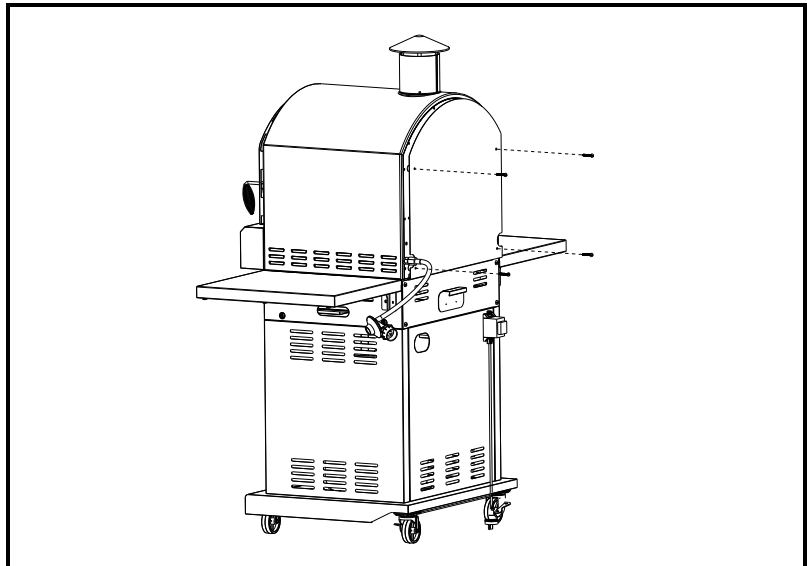

8. Finally, put back the two cooking grills, smoker box, pizza stone, base grill and flame tamer into the oven. Now you have finished replacing the bulb.

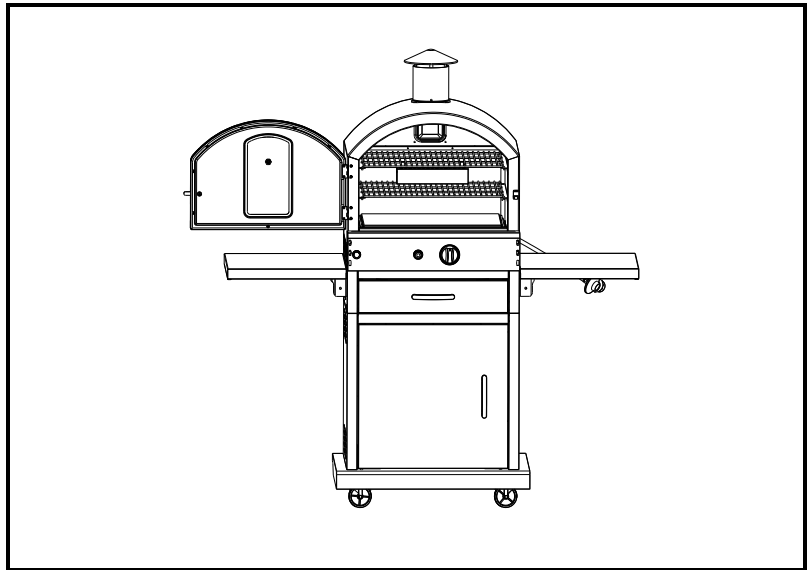

Cleaning Method

Follow Steps below for glass cover removal. Use a damp towel to clean the surface of glass cover. Make sure the glass cover is completely dry before reinstalling.



WARNING

Make sure the light switch is on “OFF” position and power plug is disconnected from power outlet prior to cleaning the glass cover.



WARNING

The light glass cover should not be in contact with water or any other liquid when it is warm. Sudden changes of temperature may cause cracks on glass cover.



WARNING

To ensure continued protection against electric shock:

- 1. Connect to properly grounded outlets only.**
- 2. Do not expose to rain.**
- 3. Keep extension cord connections dry and off the ground.**

Bulb specification

Bulb Type: Halogen

Wattage: 20 watts per bulb

Voltage: 12 volts

Please contact customer service at **1(800) 966-8126** for assistance on bulb replacement.

Replacing Battery for Electrical Igniter:

1. Remove the igniter cap by turning clockwise;
2. Replace the battery;
3. When installing new battery, ensure it is installed with the proper polarity;
4. Put on the igniter cap back by turning counterclockwise.

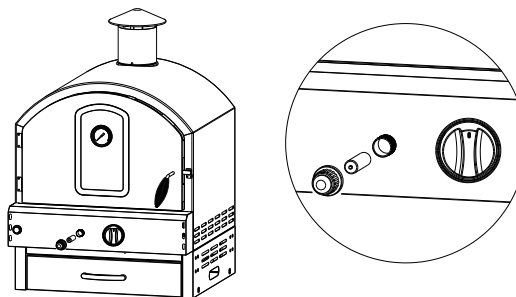

WARNING:

1. To protect against electric shock, do not immerse cord or plugs in water or other liquid.
2. Unplug from the outlet when not in use and before cleaning. Allow to cool before putting on or taking off parts.
3. Do not operate any outdoor cooking gas appliance with a damaged cord, plug, or after the appliance malfunctions or has been damaged in any manner. Contact the manufacturer for repair.
4. Do not let the cord hang over the edge of a table or touch hot surfaces.
5. Do not use an outdoor cooking gas appliance for purposes other than intended.
6. When connecting, first connect plug to the outdoor cooking gas appliance then plug appliance into the outlet.
7. Use only a Ground Fault Interrupter (GFI) protected circuit with this outdoor cooking gas appliance.
8. Never remove the grounding plug or use with a two-prong adaptor.
9. Use only extension cords with a three-prong grounding plug, rated for the power of the equipment, and approved for outdoor use with a W-A marking.

OVEN DOOR CLEANING

1. Loosen the M4*10 screw * 4 pcs that fix the oven door and then take the oven door apart from the oven.

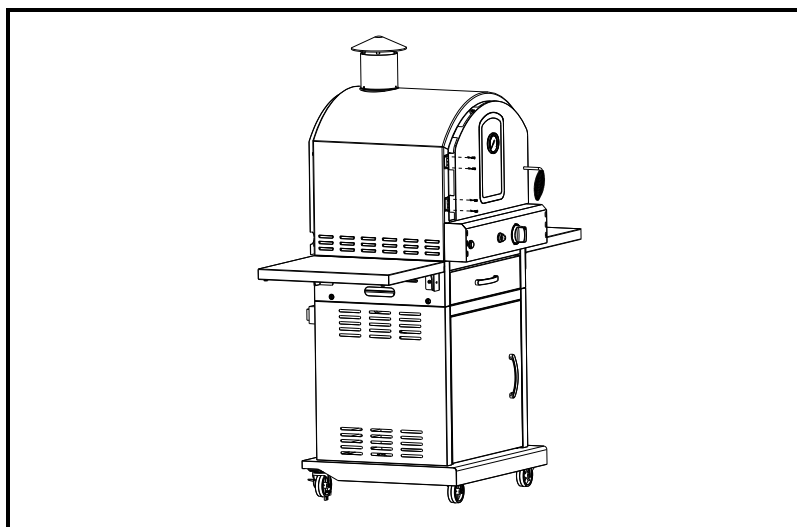

2. Loosen the M4*10 screw * 7 pcs that fix the door exterior and interior, and then loosen the M4*10 screw * 4 pcs that fix the door hinge. Then loosen the shoulder screw that attaches the door handle.

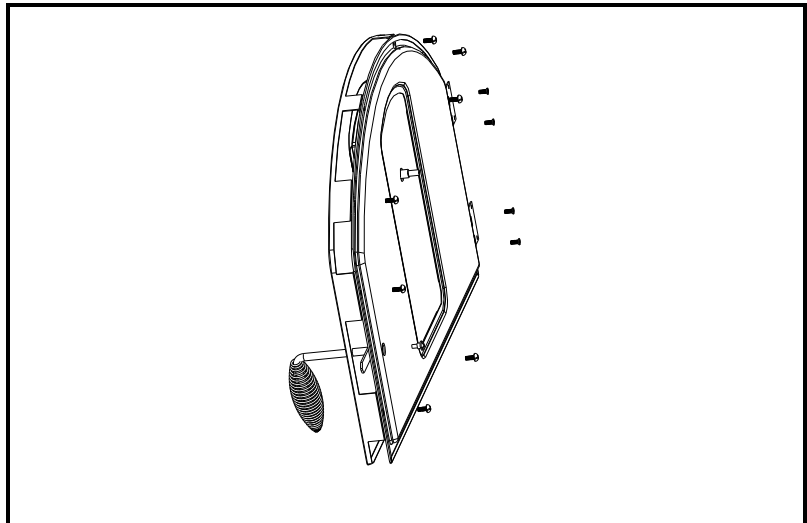

3. Use spanner 19# to loosen the nut that fix the temperature gauge. And then you can completely separate the oven door exterior and interior so as to do the cleaning.

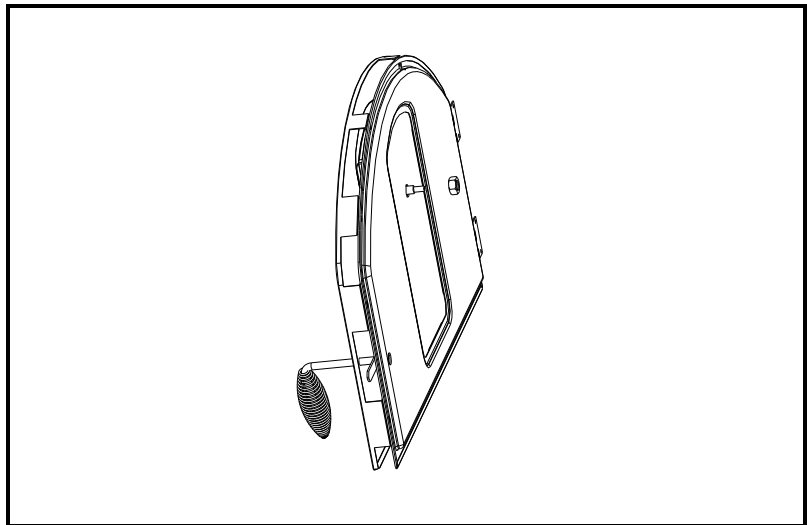

4. After cleaning, you need to re-assemble the oven door. Put the door interior onto the exterior and make every screw hole in line with each other. Use M4*10 screw * 7 pcs to fix the door interior and exterior. And then use shoulder screw to fix the handle onto the door. Finally, use M4*10 screw * 4 pcs to fix the hinge onto the door.

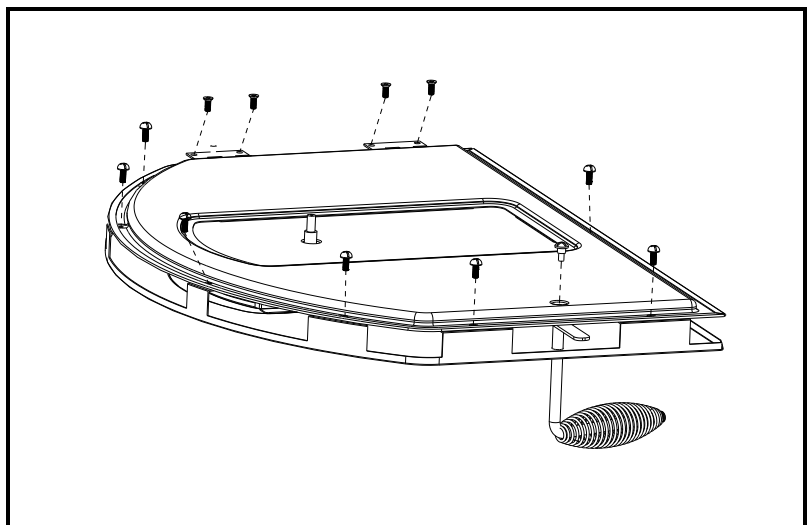

5. Use spanner or hand directly to tighten the nut that fix the temperature gauge on the glass. You can set the torque of the spanner at 4.0kgf*cm.

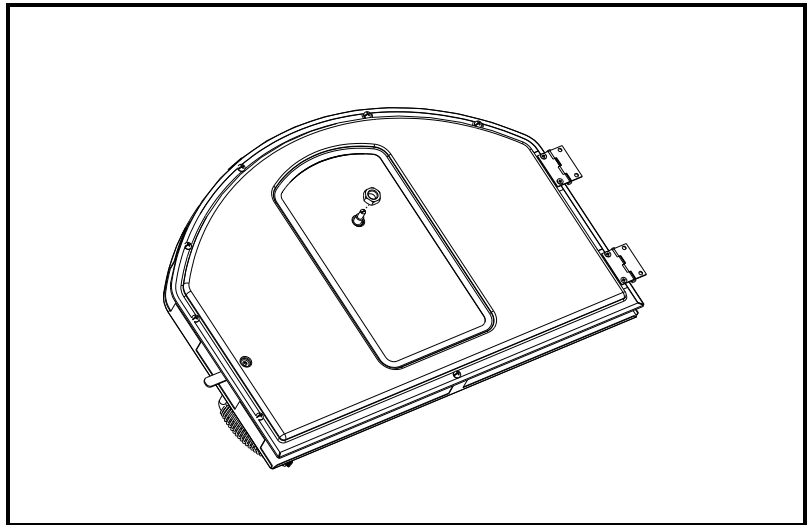

6. Use M4*10 screw * 4 pcs to fix the door onto the oven. Now you have finished cleaning the oven door.

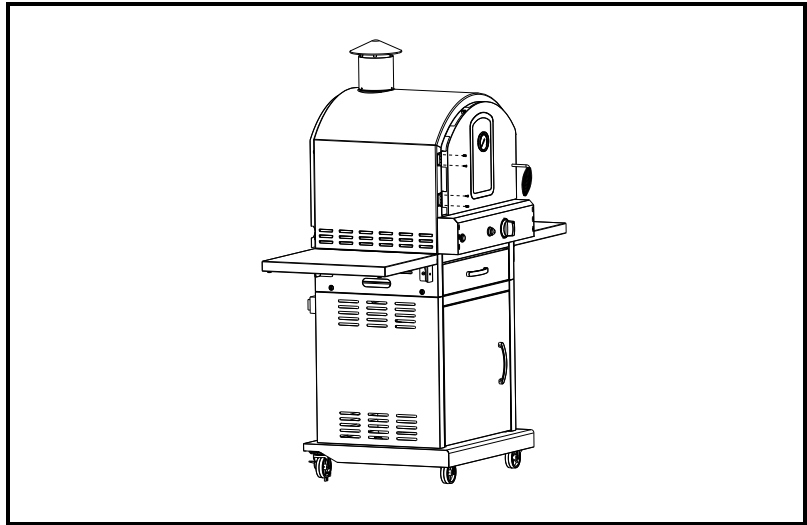

TROUBLESHOOTING

Many solutions given here can make your grilling experience safer and more enjoyable. **You can also call the customer service department at 1-866-410-0408, 7a.m. – 5 p.m., PST, Monday to Friday.**

PROBLEM	POSSIBLE CAUSE	CORRECTIVE ACTION
Grill will not light.	<ol style="list-style-type: none"> 1. The ignition wire came off the electrical igniter/valve. 2. The distance between the ignition pin and the burner is greater than 3~5 mm. 3. The ignition wire is broken. 4. The battery has died. 5. The battery is in the wrong polarity. 6. The electrode tip does not produce sparks at the burner port. 7. No gas supplied. 8. Air shutter opening is too big. 	<ol style="list-style-type: none"> 1. Reconnect the ignition wire to the electrical igniter/valve. 2. Loosen the ignition pin and adjust the distance, then fasten it again. 3. Call customer service for a replacement ignition wire. 4. Install a new AA battery. 5. Change the battery polarity. 6. Reinstall the electrode. 7. Turn on the regulator valve. 8. Loosen the air shutter and adjust the opening to a smaller size.
Burner flame is yellow and gas odor can be smelled.	<ol style="list-style-type: none"> 1. The air shutter opening is not properly set. 2. Spiders or insects block the air shutter. 3. Possible gas leaks. 	<ol style="list-style-type: none"> 1. Loosen the air shutter and adjust the opening to have blue flames. 1/4 in. opening for LPG. 1/8 in. or less opening for NG. 2. Clean blockages. 3. Check for the source of gas leaks.
Excessive flare-up.	<ol style="list-style-type: none"> 1. Grilling fatty meats. 2. Knobs on “HIGH.” 3. Spray water on gas flames. 4. Hood closed when grilling. 	<ol style="list-style-type: none"> 1. Move the meats to the warming rack if flare up continues until flame settles down. 2. Grill fatty meats when the grids are cold while the knobs are on the “LP LOW” (when using LP Gas) or “NG LOW” (when using Natural Gas) setting. 3. Never spray water on gas flames. 4. Hood up when grilling.
Burner blows out.	<ol style="list-style-type: none"> 1. LP tank is empty. 2. Burner is not aligned with the control valve. 3. Gas supply is not sufficient. 	<ol style="list-style-type: none"> 1. Refill the LP Tank. 2. Install the burner correctly. 3. Check the gas supply hose and make sure there are no leaks and no knots.
Low heat with the knob in “HIGH” position.	<ol style="list-style-type: none"> 1. Low heat is found in natural gas models. 2. Ports are blocked. 3. LP tank has run out. 	<ol style="list-style-type: none"> 1. This model is set for 7 in. natural gas usage. Please check your natural gas supply system to have correct gas pressure. Regulator is not needed for NG model. Check the orifice if you installed NG nozzles. Conversion kit provides the following nozzles:

TROUBLESHOOTING

		<table border="1" style="width: 100%;"> <tr> <td style="width: 50%;">Burner</td> <td style="width: 50%;">Orifice Size</td> </tr> <tr> <td>Main Burner</td> <td>LP Φ 1.31 mm</td> </tr> </table>	Burner	Orifice Size	Main Burner	LP Φ 1.31 mm								
Burner	Orifice Size													
Main Burner	LP Φ 1.31 mm													
		2. Clear ports of any obstructions. 3. Refill the LP tank.												
Low heat, LP gas.	The propane regulator assembly incorporates an excess flow device designed to supply the grill with sufficient gas flow. Rapid changes in pressure can trigger the excess flow device, providing a low flame and low temperature.	Please follow these instructions: 1. Make sure all burners are "OFF." 2. Open the tank valve and wait 5 minutes. 3. Light the burner one at a time following the lighting instructions listed on the door liner and Page 25 and 26.												
Low heat, natural gas.	Gas pressure is significantly affected by gas line and length of gas line from house gas line.	Check your gas line and make corrections by following the chart below: <table border="1" style="margin-top: 10px; width: 100%;"> <thead> <tr> <th colspan="2" style="text-align: center;">From House to Grill</th> </tr> <tr> <th style="width: 50%;">Distance</th> <th style="width: 50%;">Tubing Size</th> </tr> </thead> <tbody> <tr> <td>Up to 25 ft.</td> <td>3/8 in. DIA</td> </tr> <tr> <td>26 – 50 ft.</td> <td>1/2 in. DIA</td> </tr> <tr> <td>51 – 100 ft.</td> <td>2/3 in. of run 3/4 in. 1/3 in. of run 1/2 in.</td> </tr> <tr> <td>Over 101 ft.</td> <td>3/4 in. DIA</td> </tr> </tbody> </table>	From House to Grill		Distance	Tubing Size	Up to 25 ft.	3/8 in. DIA	26 – 50 ft.	1/2 in. DIA	51 – 100 ft.	2/3 in. of run 3/4 in. 1/3 in. of run 1/2 in.	Over 101 ft.	3/4 in. DIA
From House to Grill														
Distance	Tubing Size													
Up to 25 ft.	3/8 in. DIA													
26 – 50 ft.	1/2 in. DIA													
51 – 100 ft.	2/3 in. of run 3/4 in. 1/3 in. of run 1/2 in.													
Over 101 ft.	3/4 in. DIA													
Cooking light will not turn on.	1. No power supply. 2. Defective Halogen bulb. 3. Internal wiring issue.	1. Check power supply and make sure it is properly plugged in. 2. Replace the bulb. 3. Check the wiring connections under the fire box. All wire connections must be tight. If any wires are damaged they should be replaced.												



Exploded Diagram



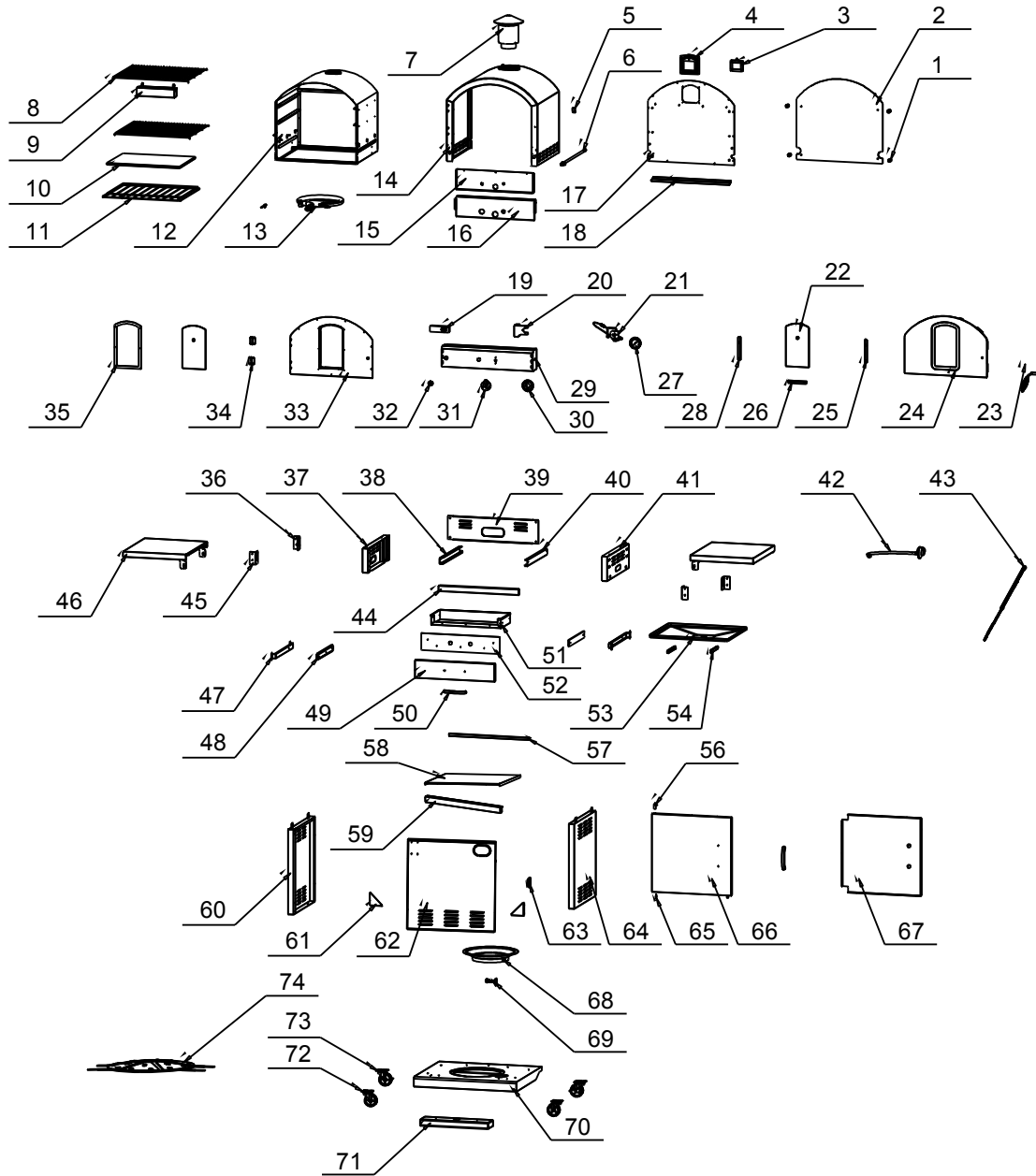



For replacement parts, call our customer service department at 1(800) 966-8126 8:30 a.m. – 5 p.m., PST, Monday to Friday.



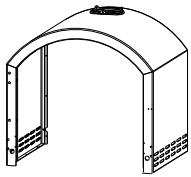
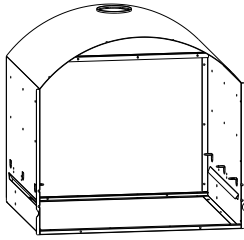
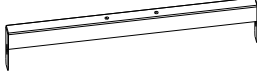
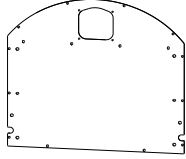
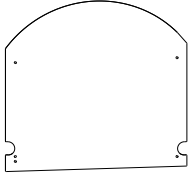
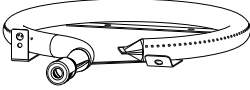

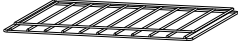

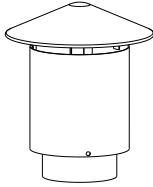
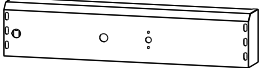
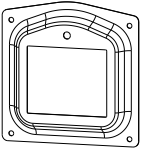
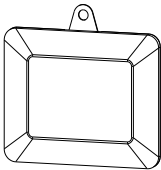

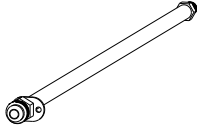
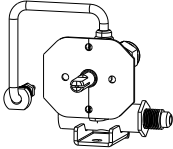
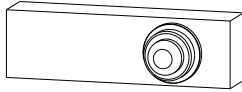
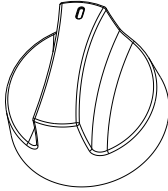
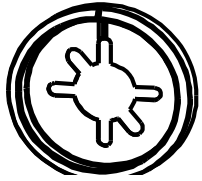



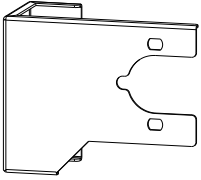
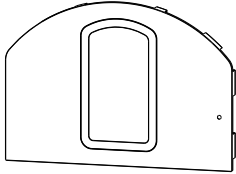
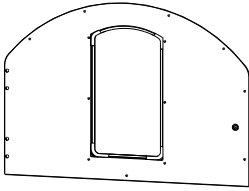
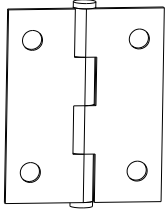
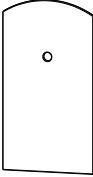

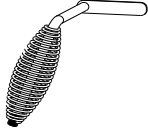
Exploded Diagram

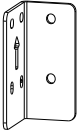
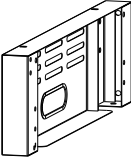
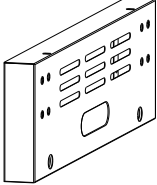
No.	Part Name	QTY	No.	Part Name	QTY
1	Heat spacer	4	38	Grease tray left bracket	1
2	Back heat-shield	1	39	Oven back support	1
3	Light assy.	1	40	Grease tray right bracket	1
4	Light bracket	1	41	Oven right supporting assy.	1
5	Handle latch	1	42	Light transformer	1
6	Gas pipe	1	43	Match holder	1
7	Chimney assy.	1	44	Camp stove superior girder	1
8	Cooking grill	2	45	Right side shelf bracket	2
9	Smoker box assy.	1	46	Side bedplate assy.	2
10	Pizza stone	1	47	Rail support	2
11	Bottom grill	1	48	Two part roller rail	2
12	Interior assy.	1	49	Drawer fascia	1
13	Round burner assy.	1	50	Door handle	2
14	Exterior	1	51	Drawer	1
15	Fascia heat shield	1	52	Drawer interior	1
16	Oven front panel	1	53	Grease tray	1
17	Back panel	1	54	Grease tray stator	2
18	N/A	1	55	Obsolete	1
19	Electronic igniter	1	56	Spring hinge assy.	1
20	Nozzle stator	1	57	Oven supporting beam	1
21	Valve	1	58	Trolley top panel	1
22	Viewing window	2	59	Trolley door horizontal beam	1
23	Door handle assy.	1	60	Trolley left side panel assy.	1
24	Door heat shield assy.	1	61	Triangle fortified	2
25	Left glass fixing bracket	1	62	Trolley back panel	1
26	Bottom glass fixing bracket	1	63	Magnet	1
27	Round temp. gauge	1	64	Trolley right side panel assy.	1
28	Right glass fixing bracket	1	65	Door axis	1
29	Control fascia	1	66	Trolley door exterior	1
30	Knob bezel	1	67	Trolley door interior	1
31	Control knob	1	68	Tank tray assy.	1
32	Light switch	1	69	Tank fastener	1
33	Oven door assy.	1	70	Base tray assy.	1
34	Oven door hinge	2	71	Weight	1
35	Glass pressing	1	72	Swivel castor without lock	2
36	Left side shelf bracket	2	73	Swivel castor with lock	2
37	Oven left supporting assy.	1	74	Flame Tamer	1

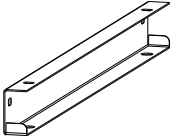
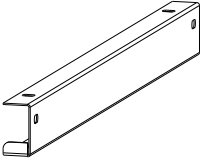

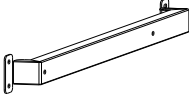

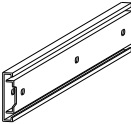

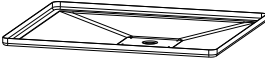
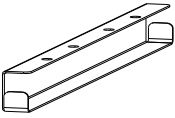





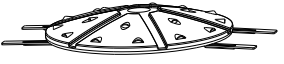

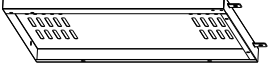
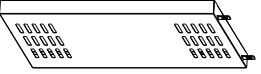
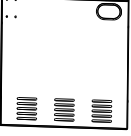
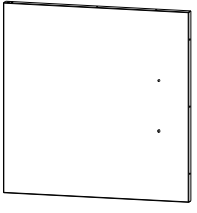
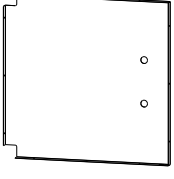
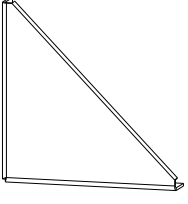

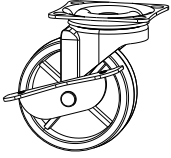
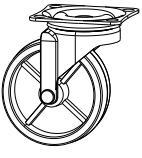
Replacement Parts

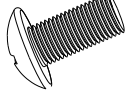
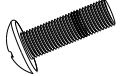
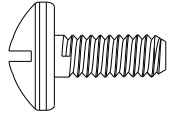
1. BG070-01 Oven Exterior * 1 pc	2. BG070-02-00B Oven Interior * 1 pc	3. BG070-24 Burner Bracket Beam * 1 pc	4. BG070B-03-01 Oven Back Panel * 1 pc
			
5. BG070-03A Oven Back Heat Shield * 1 pc	6. BG070-10-00B Burner Assy. * 1 pc	7. BG070-18 Cooking Grate * 2 pcs	8. BG070-17B Base Grate * 1 pc
			
9. BG070-32A Pizza Stone * 1 pc	10. BG070-13-00 Smoker Box * 1 pc	11. BG070-08-00C Chimney Assy. * 1 pc	12. BG070B-05A Control Fascia * 1 pc
			
13. BG070B-03-02 Light Bezel * 1 pc	14. BG094B-01-10 Light Assy. * 1 pc	15. BG070B-70 Grease Stopper * 1 pc	16. BG070-19A Gas Pipe * 1 pc
			
17. BG070-20A Valve Assy. * 1 pc	18. DHL-128-1Q-2D-1 Electric Igniter * 1 pc	19. BG179-94 Control Knob * 1 pc	20. BG179-73-00 Knob Bezel * 1 pc
			
21. BG070B-66 Orifice Holder * 1 pc	22. BG070B-09-03-00 Oven Door Heat Shield * 1 pc	23. BG070B-09-00B Oven Door Assy. * 1 pc	24. BG070-45 Oven Door Hinge * 2 pc

Replacement Parts

			
25. BG070B-38 Oven Door Glass * 2 pc	26. BG070-30 Temp. Gauge * 1 pc	27. BG070-12-00 Oven Door Handle Assy. * 1 pc	28. BG070-76-00 Sideshelf * 2 pcs
			
29. BG070B-30-01 Left Sideshelf Bracket * 2 pcs	30. BG070B-30-02 Right Sideshelf Bracket * 2 pcs	31. BG070B-57-00 Oven Left Holder Panel * 1 pc	32. BG070B-58-00 Oven Right Holder Panel * 1 pc
			
33. BG070B-59 Oven Back Seal Panel Oven Left Holder Panel * 1 pc	34. BG070B-60-01 Grease Tray Left Bracket Oven Left Holder Panel * 1 pc	35. BG070B-60-02 Grease Tray Right Bracket Oven Left Holder Panel * 1 pc	36. BG070B-71 Oven Upper Beam * 1 pc
			
37. BG070B-65 Oven Supporting Beam * 1 pc	38. BG070B-64 Drawer Rail Bracket * 2 pcs	39. BG070-75 Drawer * 1 pc	40. BG070B-63-00 Drawer Fascia * 1 pc
			
41. BG0614B-04-13 Drawer Rail * 2 pcs	42. MCG4-04-01 Handle * 2 pcs	43. BG070B-61 Grease Tray * 1 pc	44. BG070B-69 Fat Cup Bracket * 2 pcs
			
45. Obsolete Part	46. TYQ-9B-LL516-00 Hose and Regulator * 1 pc	47. DGP350NP-55-00 Match Holder * 1 pc	48. BG070B-73-00 Flame Tamer Assy. * 1 pc

Replacement Parts

			
49. BG070B-53 Trolley Top Panel * 1 pc	50. BG070B-54 Trolley Door Horizontal Beam * 1 pc	51. BG070B-50-00 Trolley Left Sidepanel Assy. * 1 pc	52. BG070B-51-00 Trolley Right Sidepanel Assy. * 1 pc
			
53. BG070B-52 Trolley Back Panel Assy. * 1 pc	54. BG070B-55 Trolley Door Exterior * 1 pc	55. BG070B-56 Trolley Door Interior * 1 pc	56. BG070-40 Triangle Bracket * 2 pcs
			
57. DGP350SNP-30-00 Cylinder Tray Assy. * 1 pc	58. BG070-78-00 Trolley Base Panel Assy. * 1 pc	59. BG1073B-52 Swivel Castors * 2 pcs (with lock)	60. BG1073B-52B Swivel Castors * 2 pcs (without lock)
			
61. M5*30 Screw * 4 pcs	62. M6*12 Screw * 37 pcs	63. M4*10 Screw * 12 pcs	64. M4*8 Screw * 3 pcs
			
65. BG070-41 PVC Feet Washer * 8 pcs	66. ES22-A10-4 PVC Feet * 4 pcs	67. ST1222-09-09 Oven Back Panel Heat Insulation Washer * 4 pcs	68. M6*40 Screw * 2 pcs
			
69. M5*35 Screw * 4 pcs	70. M5*10 Screw * 24 pcs	71. M3*12 Screw * 2pcs	72. Thermocouple* 1pc THERMO-OV
			

Attach the “installation flanges” to your oven. This will support your oven in the island. (Sold Separately)

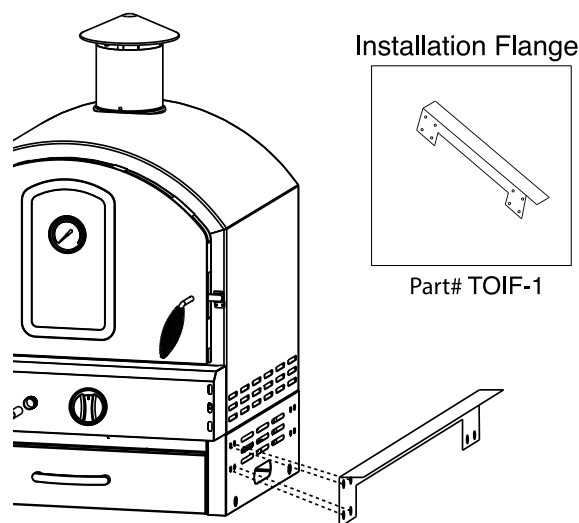

After your island is made with the correct cut out dimensions, and you have your flanges attached, slide your oven into your cut out. Then plug in your electrical and connect gas to your oven.

“Built In” Cut Out Dimensions

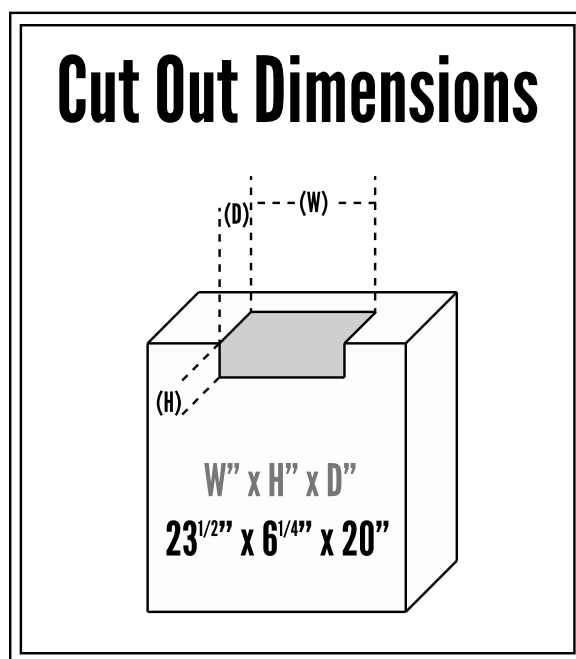

GOLD STANDARD WARRANTY

Your investment in AMD Direct products is backed by the strongest warranty in the industry. In addition to precision engineering and outstanding performance, AMD Direct products include our GOLD STANDARD LIFETIME WARRANTY with all replacement parts 100% non-prorated. Effective with purchases as of 3/1/23.

AMD Direct Warranty is valid for original purchaser at original site of delivery with proof of purchase and photo documentation only. Registration form must be submitted online within 30 days of the purchase date to validate the warranty. Warranty is void upon transfer of ownership. Warranty does not apply to products installed in any commercial, rental, or nonresidential application that have not maintained proper upkeep. Warranty covers replacement parts only. Manufacturer is not responsible for labor or labor-related costs. Warranty does not cover discoloration, surface rust, corrosion, or oxidation, which may occur due to harsh environments, chemicals, or overheating. Warranty will not apply for damage resulting from improper installations, abuse, extreme environments, grease fires, or misuse. Proof of regular and proper maintenance is required. Coastal, humid, and/or salt environments are subject to manufacturer review. All out-of-box claims must be made within 30 days of purchase and must be made prior to installation. Any product installed damaged will be considered damaged during installation and not covered under warranty. Warranty and registration forms are available at www.amddirect.com/register. Please be advised - all display models are sold "as is" and the warranty covers the following items only: main burners (Gold Standard Lifetime Warranty), grates (Gold Standard Lifetime Warranty), burner covers (Gold Standard Lifetime Warranty). All warranties are subject to the review and approval of the manufacturer.

14520 DELTA LANE SUITE 105,
HUNTINGTON BEACH, CA 92647

800.966.8126

AMDDIRECT.COM



AMD DIRECT GAS APPLIANCES (GRILLS, SIDE/POWER BURNERS, GAS GRIDDLE & OVEN)

- Gold Standard Lifetime Warranty on Construction and Manufacturer Defects
- Gold Standard Lifetime Warranty on Stainless Steel Construction
- Gold Standard Lifetime Warranty on Cooking Grates, Burners, Burner Covers, Valves, Flame Tamers, and Heat Zone Separators, Temperature Gauges, & Hood Springs
- Gold Standard Lifetime Warranty on Briquette Systems
- 3 Year Warranty on all Other Parts, Components, & Electrical, Including: LED Bulbs, Wire Harness, & Switches; Power Source Wire; Transformer; Interior Halogen Light Wire & Bulb

VENT HOODS, REFRIGERATION, COLD STORAGE & SINKS

VENT HOODS

- 5 Year Warranty on all Stainless Steel Construction
- 3 Year Warranty on Blowers, LED Lighting, Wiring Harness and Switches

15" & 24" REFRIGERATION MODELS

- 3 Year Warranty on all Construction Including Compressors
- 1 Year Warranty on Transformer, LED Bulbs, LED Harness, Power Source Wire, LED Switches, Interior Halogen Light Wire/Bulbs

21" REFRIGERATION MODELS

- 1 Year Warranty on all Construction & Electrical Components Including Compressor, Transformer, LED Bulbs, LED Harness, Power Source Wire, LED Switches, Interior Halogen Light Wire/Bulbs

COLD STORAGE & SINKS

- Gold Standard Lifetime Warranty on Ice Chests
- Gold Standard Lifetime Warranty on Drains & Faucets

DRAWERS, DOORS, GRILL LINERS, & CARTS

- Gold Standard Lifetime Warranty on Construction, Workmanship and Materials for all Stainless Steel Parts, Including Doors, Drawers, Grill Liners, & Carts
- 3 Year Warranty on Electrical (Warming Drawers)

COVERS

- Gold Standard Lifetime Warranty on Covers, Including Grills, Carts, Side/Power Burners, Gas Griddle & Oven

COMMERCIAL APPLICATIONS

GAS GRILLS

- Gold Standard Lifetime Warranty on Workmanship, Construction, & Manufacturer Defects for All Commercial and/or Hospitality Applications
- Warranty is Void Upon Misuse, Including Lack of Regular Cleaning, Vandalism, or Theft
- Warranty is Valid Only if Regular Maintenance is Exercised. Due to the Nature of Commercial Applications (Multiple Users, Lack of Control of Use, etc.) Regular Maintenance is Mandatory