

Adjustable Trailer Hitch

User Manual

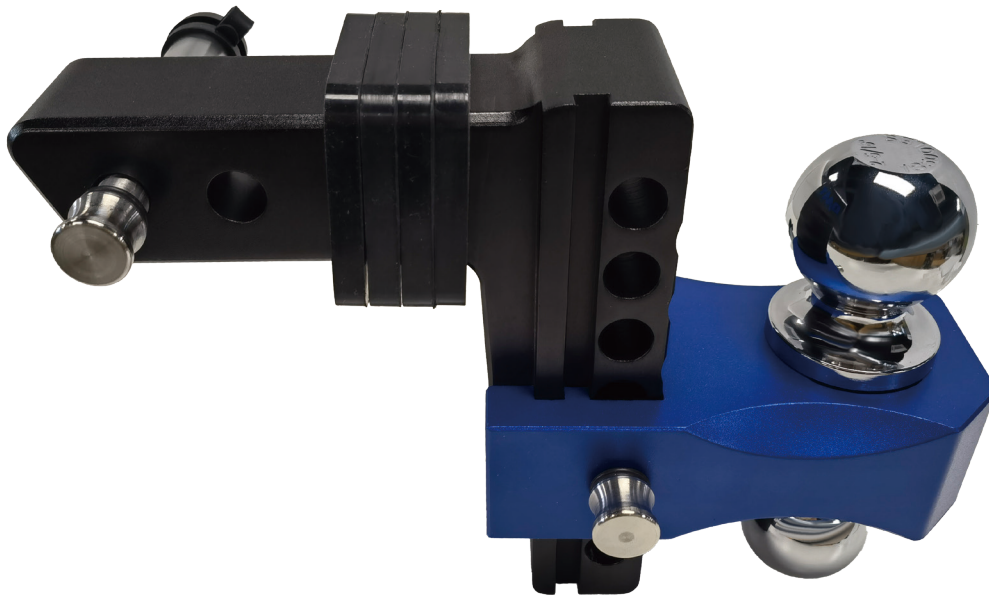

Read Carefully Before Installation and Use
Keep for Future Reference

Disclaimer

Read this disclaimer completely and carefully before proceeding with the rest of the manual content.

1. **Warranty**

This Orion Motor Tech product is sold with all expressed or implied warranties, including but not limited to the implied warranties of merchantability and fitness for a particular purpose.

Refer to the sales page for the warranty information regarding this product.

2. **Product Modifications**

Any modifications or alterations to OMT products void any warranties and may result in damage or injury. OMT shall not be liable for any damages resulting from such modifications or alterations.

3. **Compliance with Laws**

Customers shall be liable for ensuring that the use of OMT products complies with all applicable laws and regulations in their respective jurisdictions. OMT assumes no responsibility for any violations of laws or regulations resulting from the use of OMT products.

4. **Correct Use**

Always use OMT products only as directed in the accompanying manuals. Failure to follow instructions may result in injury or damage.

Always ensure the assembly, installation, operation, maintenance, or repair of OMT products is carried out by a competent person.

Always make maintenance regularly throughout OMT products' lifecycles; you have the liability to keep the products operating as intended.

Always wear appropriate protective gear.

5. **Third-Party Products**

OMT shall not be liable for any damages or losses resulting from the use of third-party products in conjunction with OMT products. Customers shall refer to the third-party's guidelines or/and warranties (if any) for any third-party products used.

6. **Limitation of Liability**

OMT shall not be liable for any direct, indirect, punitive, incidental, special, or consequential damages to property or life, whatsoever arising out of or connected with the use or misuse of OMT products. In no event shall OMT's liability exceed the value of the products sold.

This disclaimer states the entire obligation of OMT with respect to OMT products. If any part of this disclaimer is determined to be void, invalid, unenforceable, or illegal, including but not limited to the warranty disclaimers, liability disclaimers, and liability limitations set forth above, the invalid or unenforceable provision will be deemed superseded by a valid and enforceable provision that most closely matches the intent of the original provision and the remainder of the agreement shall remain in full force and effect.

Contents

Safety Information	1
General Instructions	1
Compatibility	1
Installation/Removal	2
Towing	3
Product Care	4
Package List	5
Product Diagram	6
Installation	7
Disconnecting the Locks from the Hitch Pins	7
Installing the Ball Mount on the Towing Vehicle	8
Connecting the Dual-Ball Assembly to the Ball Mount	10
Attaching the Towed Trailer’s Coupler to a Ball.....	11
Maintenance	12

Safety Information

Danger

General Instructions

- The instructions provided herein are **MAINLY** about this trailer hitch and **ONLY** for general information regarding vehicles towing trailers.

ALWAYS perform **ALL** tasks in **FULL** compliance with the manuals of your vehicle and trailer.

After installing this trailer hitch, test its functionality with your vehicle and trailer at low speed in a safe area **BEFORE** use.

Failure to do so can invite accidents, resulting in serious property damage and severe personal injury.

- Follow **ALL** guidelines in this manual carefully.

Failure to do so can invite accidents, resulting in serious property damage and severe personal injury.

- **ONLY** use this trailer hitch for its intended purpose, connecting a towing vehicle to a towed trailer.

It is **NOT** a toy and should **NOT** be used playfully or carelessly.

Any other use **NOT** specified herein could potentially pose risks and void **ALL** warranties stated or implied.

Compatibility

- Carefully read the label and marks that come with this trailer hitch as well as the manuals of your vehicle and trailer, making clear the towing capacity and equipment specifications **BEFORE** installation and use.

- **ALWAYS** ensure that the L-shaped ball mount fits the size of your vehicle's hitch receiver.

See the product label for the specific requirement (**2"** or **2.5"**).

- **ALWAYS** ensure that the trailer hitch ball being used matches the **Max Trailer Weight** and the **Max Tongue Weight** specified in your vehicle's manual.

The **Max Trailer Weight** indicates the maximum weight that the vehicle is rated to tow safely, which covers the **TOTAL** weight of the trailer when it is **FULLY** loaded.

The **Max Tongue Weight** refers to the maximum downward force that can be safely applied to the ball by the trailer's tongue weight, which is crucial for maintaining stability and control in towing. The tongue weight should be **10%–15%** of the total trailer weight.

See the chart on the product label for detailed requirements.

- **NEVER** exceed your vehicle's or the trailer hitch's towing capacity.

Failure to follow this **WILL** invite accidents, bringing about serious property damage and severe personal injury.

Safety Information

Installation/Removal

- **DO NOT** allow installation or removal by children, by persons whose mental or physical condition precludes safe use, or by anyone unfamiliar with this trailer hitch and your vehicle or trailer.
- **DO NOT** install or remove this trailer hitch while you are tired or under the influence of drugs, alcohol, or **ANY** medication that negatively affects your judgment or reflexes.
- **ALWAYS** keep children, bystanders, and pets away during work.
Restrict access to your work area as needed.
- **ALWAYS** install or remove this trailer hitch on stable and level ground in clean and well-lit places.
Sloped surfaces and cluttered or dark areas invite accidents.
- **ALWAYS** wear appropriate personal protective equipment (PPE) during work.
ANSI and OSHA-approved hand protection is required.
Eye and body protection as well as nonslip footwear are highly recommended.
- **ALWAYS** dress properly for automobile-related tasks.
DO NOT wear loose clothing or jewelry during work.
- **ALWAYS** keep hair, clothing, gloves, hoses, and other tools away from **ANY** moving parts during work.
- **ALWAYS** know and understand the specific safety warnings and instructions for your vehicle and trailer **BEFOREHAND**.
Make sure the vehicle has been **FULLY** parked and **ALL** wheels have been **FULLY** chocked **BEFORE** work.
NEVER leave the engine active or the parking brake disengaged.
- **DO NOT** install this trailer hitch if **ANY** signs of wear or damage are detected on this product or the connectors on your vehicle and trailer.
Replace **ANY** problematic parts **BEFORE** continuing work.
- Be careful **NOT** to drop the ball mount or dual-ball assembly.
DO NOT place **ANY** body parts in areas where they may accidentally fall.
- **DO NOT** overreach during work.
Keep proper footing and balance at **ALL** times.
- **DO NOT** force this trailer hitch.
Stop work and address the issue(s) as needed if **ANY** abnormalities occur.

Safety Information

- Exercise **EXTREME** caution with **ANY** possible pinching points, moving parts, or objects that may suddenly spring out during work.
- In case of an accident or injury, have a first aid kit and a communication device (**e.g., a phone**) readily available. Know the locations of emergency medical facilities as well.
- **ALWAYS** double-check that **NO** looseness exists **AFTER** making each connection and finishing the entire installation process.
- **ALWAYS** remember to remove **ANY** keys from the locks of this trailer hitch **AFTER** installation.

Towing

- **ONLY** use this trailer hitch on appropriate vehicles that are capable of towing your trailer, such as trucks, SUVs (sport utility vehicles), crossover vehicles, and vans.

HOWEVER, read the manuals of the specific models and consult professionals as needed **BEFORE** making your decisions.

- **ALWAYS** ensure that **ALL** parts and connections **ARE** correct, intact, and securely tightened **BEFORE** towing.
- **NEVER** use this trailer hitch to tow **WITHOUT** the provided cushion washers or O-rings.
- **NEVER** leave **ANY** keys or adjustment tools on this trailer hitch **DURING** towing.
- **ALWAYS** obey **ALL** applicable laws and regulations **DURING** towing.

Pay special attention to the dress code, load restrictions, and speed limits.

- **ALWAYS** prevent a jackknife situation **DURING** towing.

Reduce the load on your trailer as much as possible.

Avoid slamming on the brake at **ALL** times.

- **ALWAYS** avoid swaying and fishtailing **DURING** towing.

Distribute the weight evenly on your trailer.

Refrain from towing in strong winds or gales.

Mind your speed and allow sufficient braking distances.

- In the event that fishtailing occurs, stay calm and **DO NOT** brake suddenly.

Gently steer in the direction of the fishtail to help straighten out the trailer while easing off the accelerator to slow down gradually. Keep an eye on your mirrors to monitor the situation and ensure the safety of other drivers.

Once you have regained control, find a safe place to pull over and address any issues that may have caused the fishtailing.

Safety Information

- Check this trailer hitch for misalignment, looseness, wear, and damage **BEFORE** and **AFTER** towing.

Realign, retighten, or replace any problematic parts **BEFORE** further use.

Towing with any problematic trailer hitch is **EXTREMELY** dangerous and **WILL** cause accidents and injuries.

Product Care

- For best results, keep this trailer hitch clean and dry.

Remove any dust, debris, grease, and oil **BEFORE** and **AFTER** each use.

- **ALWAYS** maintain this trailer hitch.

For best results, apply appropriate lubricants to ensure its functionality and prolong its lifespan.

- **DO NOT** use abrasive or caustic cleaners for this trailer hitch.

- **DO NOT** soak this trailer hitch in **ANY** cleaning fluid.

For best results, avoid prolonged exposure to rain, snow, or pressurized spray.

- **DO NOT** replace **ANY** parts of this trailer hitch with nonidentical ones.

- **DO NOT** disassemble the dual-ball assembly except for repair or replacement purposes.

- Store this trailer hitch out of the reach of children and pets **AFTER** each use.

- Automobile-related tasks can be dangerous.

This manual and the separate manuals of your vehicle and trailer cannot cover every possible situation that may arise.

Take sufficient training **BEFORE** use.

Consult experienced and proficient experts as needed.

Use good judgment at **ALL** times.

Package List

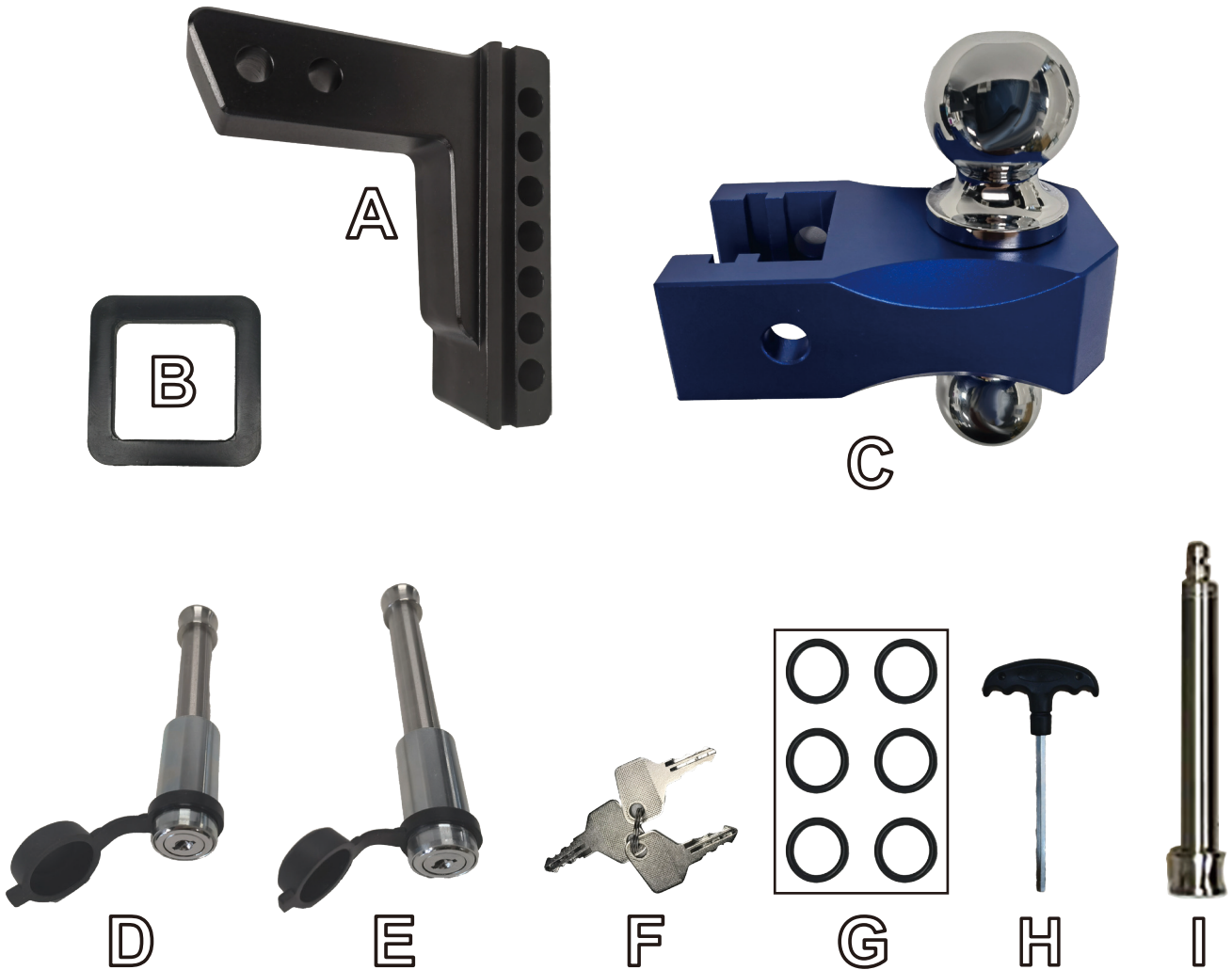

Item	Name	Qty.
A	Ball Mount	1
B	Cushion Washers	4
C	Dual-Ball Assembly	1
D	Short Hitch Pin with Lock	1
E	Long Hitch Pin with Lock	1
F	Keys	3
G	O-Ring Packet	1
H	T-Handle Allen Wrench	1
I	Long Hitch Pin	1

Product Diagram

Left View

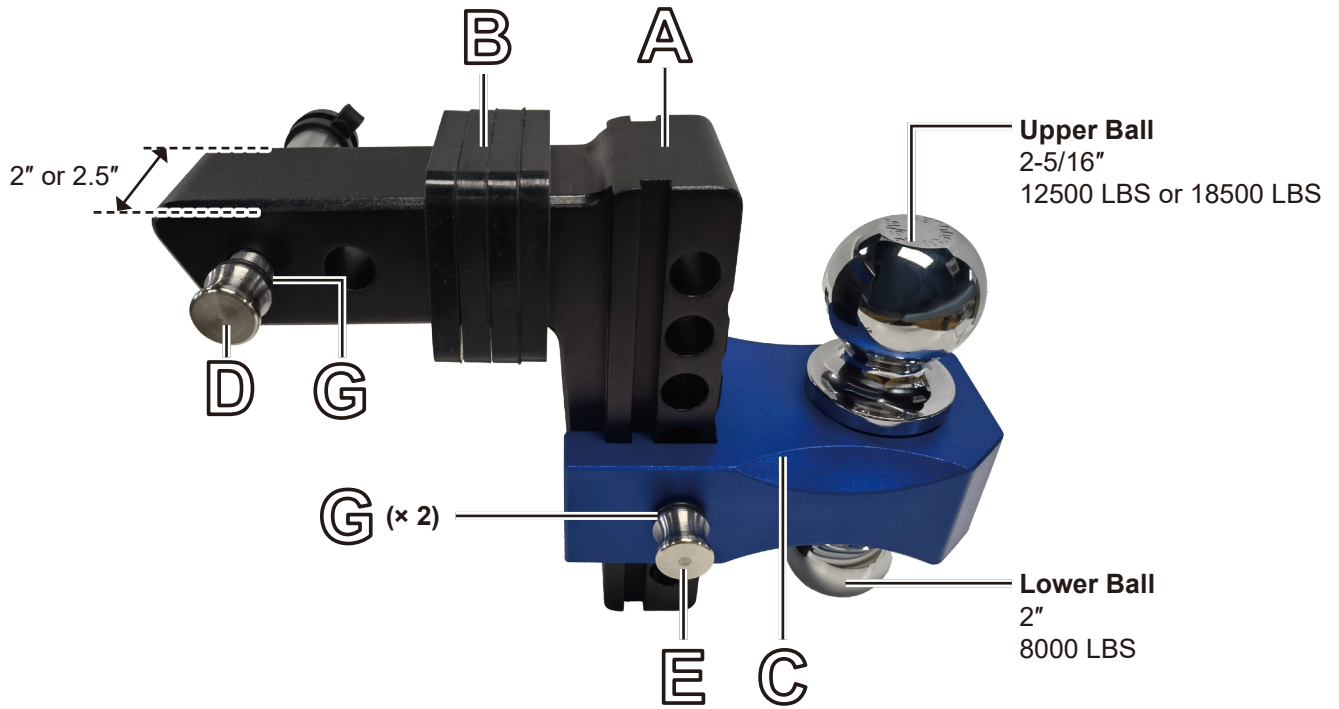

Right View

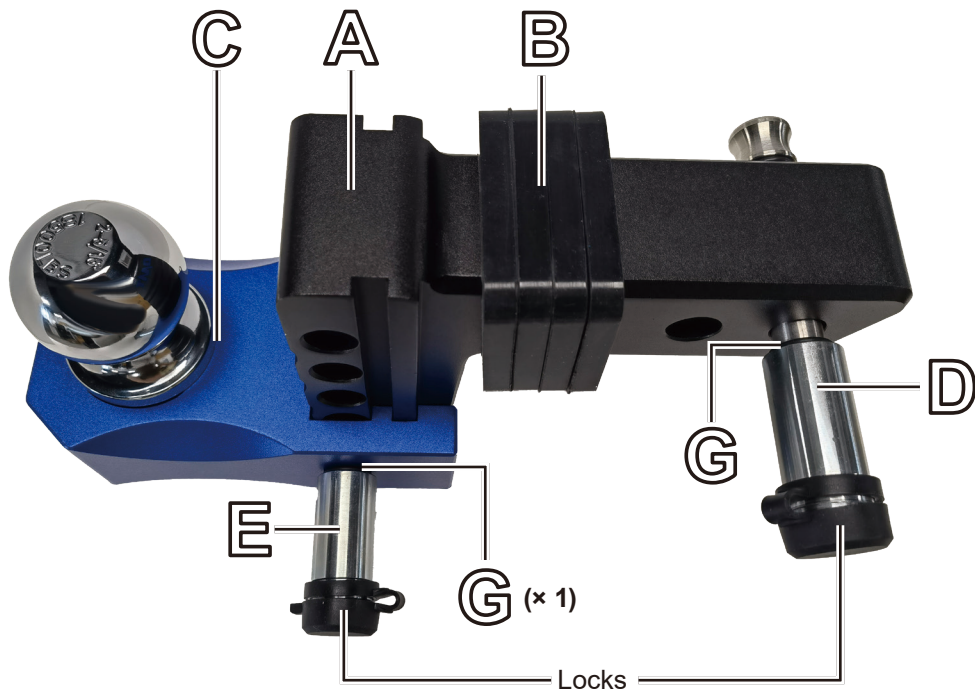

Installation

Danger

Read the **Safety Information** section **BEFORE** installation and follow **ALL** instructions therein during installation.

Pay particular attention to the towing capacity. For details, refer to the product label as well as the manuals of your towing vehicle and towed trailer. Exceeding such capacity **WILL** invite accidents and pose safety hazards.

Note:

Park your vehicle properly in front of your trailer on a stable level surface **BEFORE** installing the trailer hitch:

- Shut off the engine and engage the parking brake.
- Allow the hitch receiver to face and align with the trailer's coupler.
- Chock all wheels to prevent accidental slipping.

Disconnecting the Locks from the Hitch Pins

1. Pull away the caps of the locks on the hitch pins (**D**, **E**).



2. Insert the keys (**F**) into the locks and turn them to either side.
3. Slide the locks away from the pins and remove the keys.

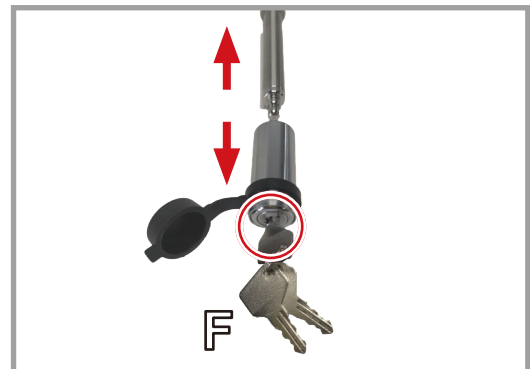

Installation

4. Replace the caps, fully covering the key holes.



Installing the Ball Mount on the Towing Vehicle

Note: Ensure that the inner width of your vehicle's hitch receiver fits the ball mount's 2 in. or 2.5 in. head width.

Refer to the label coming with this product or on **Page 11**.

1

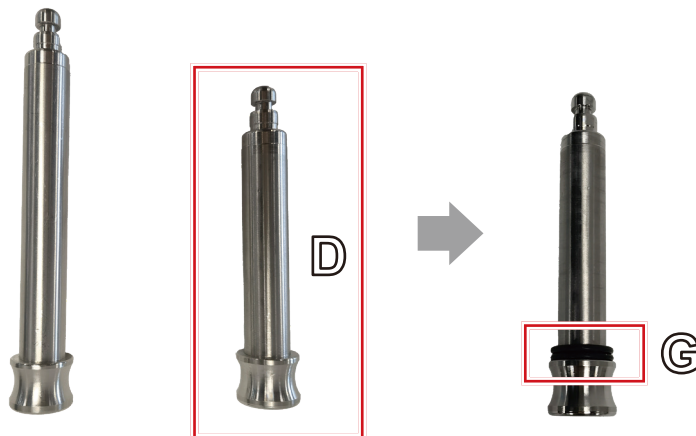

- a. Select the short hitch pin (**D**).
- b. Slide several O-rings (**G**) onto the larger end of the pin.

2

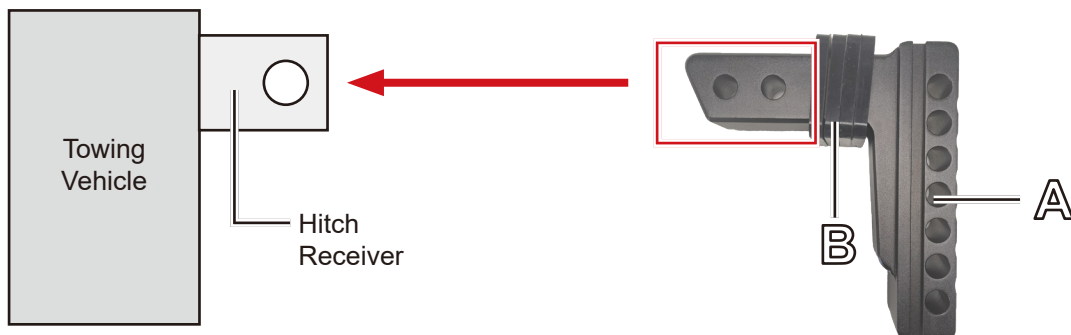

- a. Attach the cushion washers (**B**) to the L-shaped ball mount (**A**).
- b. Insert the mount into your towing vehicle's hitch receiver.
- c. Align the receiver's holes with the appropriate slot in the mount.

Installation

3

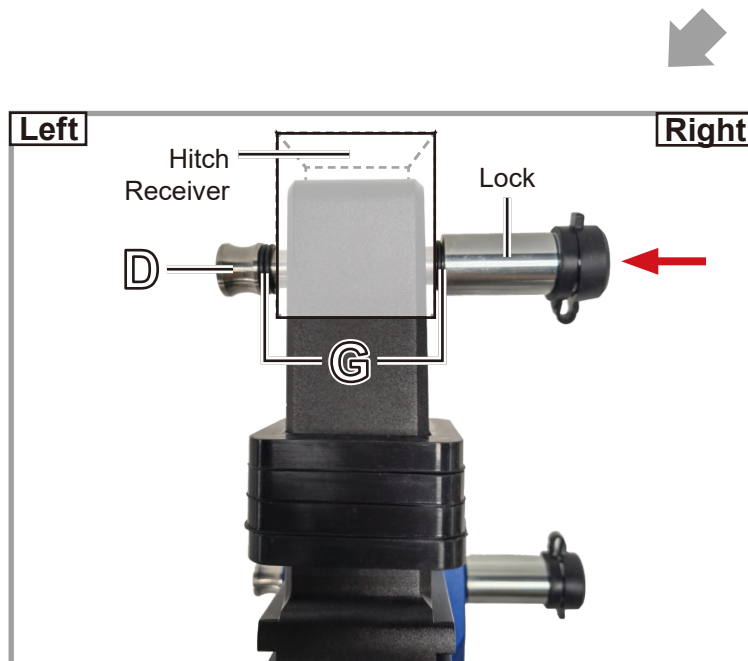
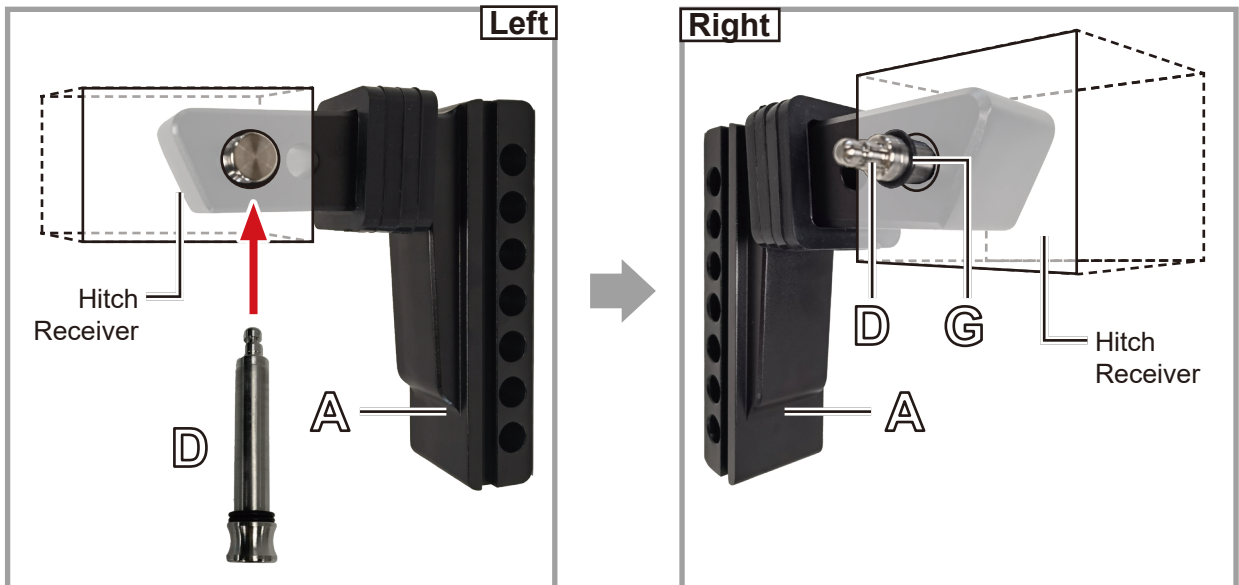

- Pass the short hitch pin (**D**) through the holes and slot, connecting the ball mount (**A**) to the receiver.
- Slide several O-rings (**G**) onto the pin at the opposite side.
- Push either lock removed in **Step 1** onto the pin **UNTIL** it clicks into place.
- Pull the lock, testing that it is already securely tightened.

Installation

Connecting the Dual-Ball Assembly to the Ball Mount

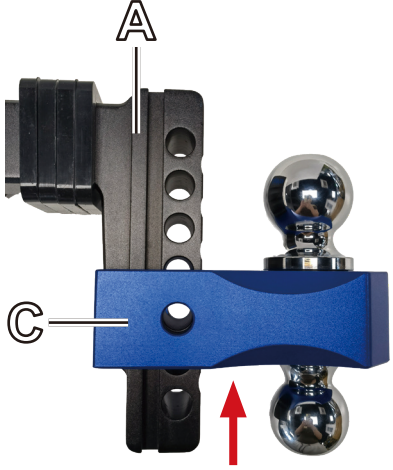
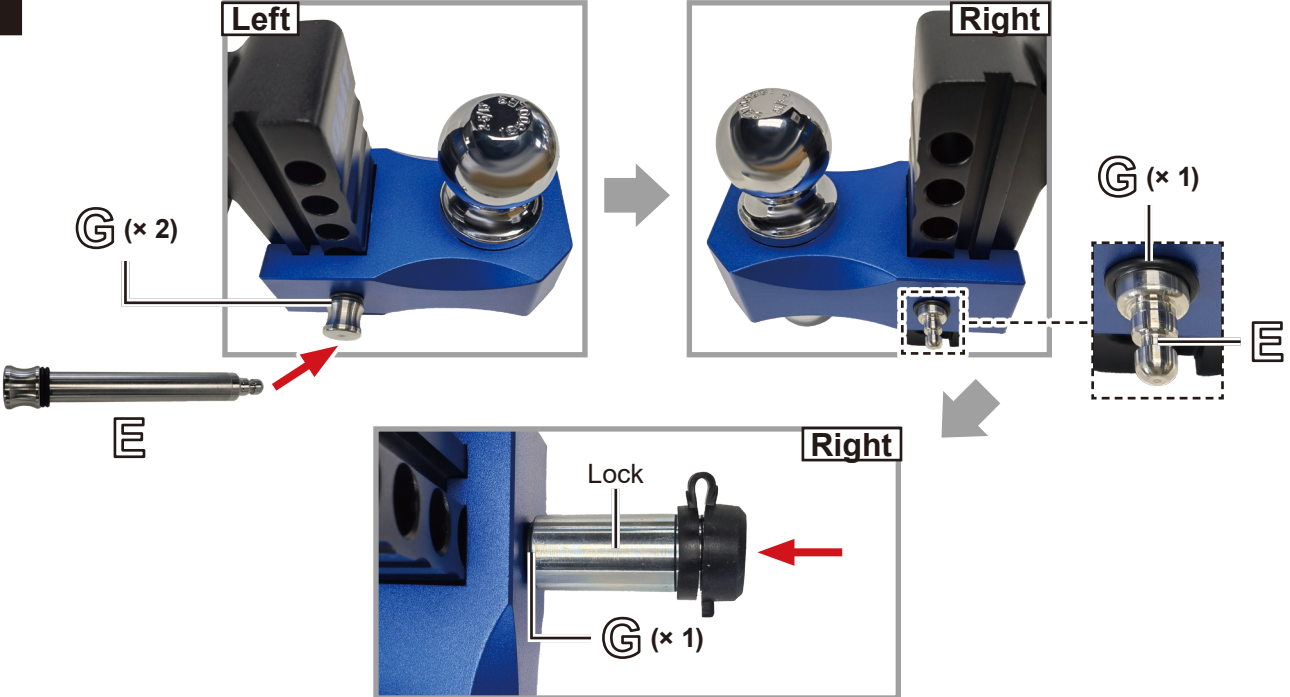
<p>1</p>  <p>Slide TWO O-rings (G) onto the larger end of the long hitch pin (E).</p>	<p>2</p>  <p>Slide the dual-ball assembly (C) up to the ball mount (A) until your trailer's coupler can reach the compatible ball.</p>
<p>3</p>  <p>a. Ensure that the slots are well aligned between the assembly and the mount.</p> <p>b. Pass the long hitch pin through these slots, connecting the assembly to the mount.</p> <p>c. Slide ONE O-ring onto the pin at the opposite side.</p> <p>d. Push the remaining lock onto the pin UNTIL it clicks into place.</p> <p>e. Pull the lock, testing that it is already securely tightened.</p>	

Installation

Attaching the Towed Trailer's Coupler to a Ball

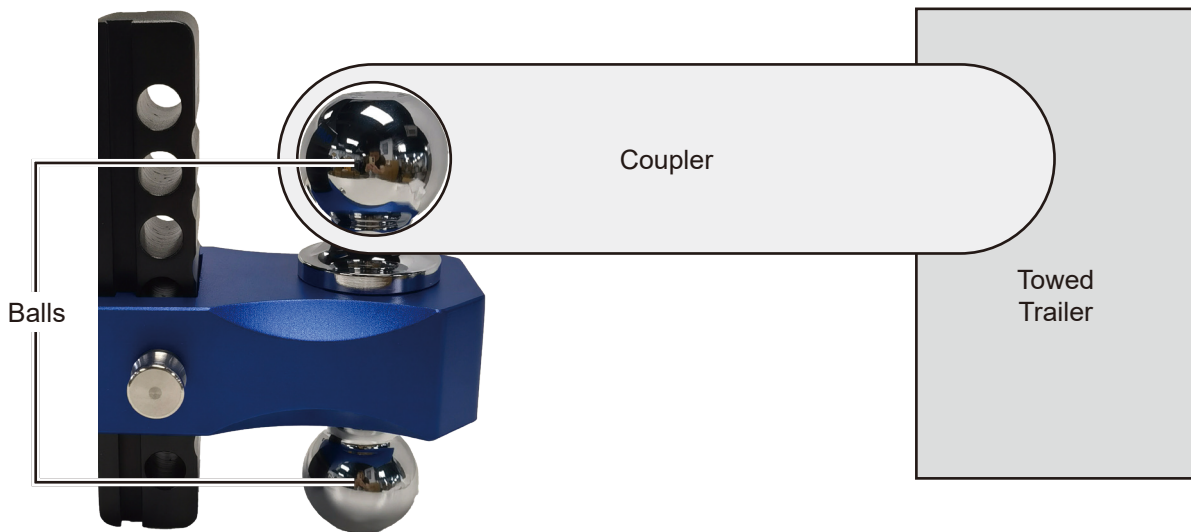

1. Read the label that comes with this product for each ball's compatibility.

Label 1:

DMT DUAL MOTOR TRAILER		
BALL SIZE	MAX TRAILER WEIGHT	MAX TONGUE WEIGHT
2"	8000 LBS	800 LBS
2-5/16"	12500 LBS	1250 LBS

FITS ALL 2" RECEIVERS.
DO NOT EXCEED VEHICLE TOWING CAPACITY!
MAKE SURE the locks are secure before towing.

Label 2:

DMT DUAL MOTOR TRAILER		
BALL SIZE	MAX TRAILER WEIGHT	MAX TONGUE WEIGHT
2"	8000 LBS	800 LBS
2-5/16"	18500 LBS	1850 LBS

FITS ALL 2.5" RECEIVERS.
DO NOT EXCEED VEHICLE TOWING CAPACITY!
MAKE SURE the locks are secure before towing.

2. Locate the ball that matches your vehicle's maximum trailer and tongue weights.

Note: *BALL SIZE and MAX TRAILER WEIGHT are marked on each ball.*

3. Attach your trailer's coupler to the ball, securing the connection with the coupler's locking mechanism.
4. Move the coupler slightly, testing that it is already securely tightened.

Danger

EVEN though you have strictly followed the instructions above, recheck the following parts **AFTER** installation and **BEFORE** towing to ensure optimal safety and functionality:

- The ball attached to the coupler, ensuring **FULL** compatibility with your vehicle's towing capacity
- The hitch pin locks and the ball-coupler connection, ensuring **NO** signs of looseness or breakage

Maintenance

Inspection

Inspect **ALL** parts of the trailer hitch and its connections for any signs of looseness, misalignment, wear, or damage between uses.

Realign, retighten, or replace any problematic parts before further use.

Danger

- **ALWAYS** ensure that the balls remain in place.
If they come loose, retighten their locking bolt using the T-handle allen wrench (H) driven by a compatible socket wrench (not included).
- **DO NOT** attempt to disassemble the dual-ball assembly unless repair or replacement is necessary.
- **DO NOT** use **ANY** nonidentical replacements.

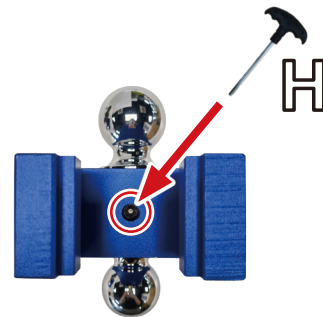

Cleaning

Clear any dirt, debris, and rust buildup off the trailer hitch between uses.

Wire brushes, steel wool, and sandpaper with dedicated degreasers or rust removers are strongly recommended.

Caution

- **DO NOT** use harsh abrasives or caustic chemicals.
- **DO NOT** soak in **ANY** cleaning fluid.

Lubrication

For best results, lubricate the trailer hitch and its connections between uses.

Penetrating oil, lithium or marine grease, and silicone or graphite lubricant are strongly recommended.

Maintenance

Storage

If the trailer hitch is not to be used for an extended period of time:

1. Reverse the installation steps, removing the hitch from your vehicle and trailer slowly and carefully.

 **Danger**

- *Ensure that the engine is off, the parking brake is engaged, and all wheels are chocked **BEFOREHAND**.*
- *Exercise caution **WHEN** the dual-ball assembly or the ball mount is about to be removed. Firmly hold them **BEFORE** disconnections to prevent accidental falls and avoid placing **ANY** body parts in areas that they may fall into.*

2. Disassemble, clean, and lubricate the hitch.

 **Danger**

***DO NOT** disassemble the dual-ball assembly unless it is necessary for repair or replacement.*

3. Place all parts of the hitch in a case.
4. Store everything in a cool dry location inaccessible to children or pets, against unauthorized use, and well protected from the elements.

Contact Us

Thank you for choosing our products! If you have any questions or comments, contact us and we'll resolve your issues ASAP!

 support@orionmotortech.com



Scan for the latest
user manual