

BougeRV

User Manual

**PWM NEGATIVE GROUND
SOLAR CHARGE CONTROLLER**



www.bougerv.com



Content

● Safety Instructions	- - - - -	1
● Features	- - - - -	2
● Technical After Services	- - - - -	3
● Identification Of Parts	- - - - -	4
● LCD Display Interface Overview	- - - - -	5
● System Wiring	- - - - -	6
● Wiring Instructions	- - - - -	7
● Key Operation	- - - - -	8
● LCD Display Interface	- - - - -	9
● Error Code	- - - - -	12
● Base Specification	- - - - -	13
● Battery Charge Parameter	- - - - -	14
● Controller Dimension	- - - - -	15
● Lead-acid Battery Working Stage	- - - - -	18
● Lithium Battery Working Stage	- - - - -	19
● Frequently Asked Questions	- - - - -	20



Safety Instructions



Please follow the safety instructions for operation, the damage caused by not following the safety instructions shall be borne by the individual.

 **Please save these instructions**

General Safety Information

1. Read all of the instructions and cautions in the manual before installation.
2. There are no repairable parts for this controller, do not disassemble or attempt to repair the controller.
3. Keep the controller from the water.
4. Make sure all connections with controller are tight.
5. Please read the product installation steps to ensure all connections are correct.

Charge Controller Safety

1. NEVER connect the solar panel array to the controller without a battery. The battery must be connected first.
2. Ensure input voltage does not exceed 55 Voc to prevent permanent damage.
3. Ensure that the output current of the solar panel does not exceed the rated charging current of the controller.

Battery Safety

1. Do NOT let the positive (+) and negative (-) terminals of the battery touch each other.
2. Explosive battery gases may be present while charging. Be certain there is enough ventilation to release the gases.
3. Be careful when working with large lead-acid batteries. Wear goggles and have fresh water available in case there is contact with the battery acid.
4. Over-charging and excessive gas precipitation may damage the battery plates and activate material shedding on them. Too high of an equalizing charge or too long of one may cause damage. Please carefully review the specific requirements of the battery used in the system.

Features

1. 1.57*1.18inch (40*30 mm) large backlit color screen (10A is black&white screen).
2. Easier to check the working status of the battery with the function of displaying the charging voltage and charging current alternately.
3. It is compatible with Li, SEL, FLD, AGM, GEL, LTO, and LFP batteries, and auto-voltage identification is available for lead-acid batteries.
4. Built-in reverse connection protection, open-circuit protection, high-temperature protection, and over-current/short-circuit protection, which is all self-recovery type, with no damage to the controller.
5. Ultra-low heat generation, equipped with a heavy-duty heat sink, ensures the maximum output of the controller.
6. With the USB output, maximum current up to 2A, supporting high current charging of iPhone, iPad, and Android mobile phones and other devices.
7. Complete multi-stage PWM charge management.
8. 32-bit high-speed master control chips.

Technical After Services

BougeRV provides **1-on-1 Solar Solution**.

If you have any questions during use, please feel free to contact us:

 service@bougeRV.com

 **1-669-232-7427**

 www.bougeRV.com

 **1-669-232-7427**
WhatsApp

If you could provide the following relevant information to our email (**service@bougeRV.com**) before contacting us; we can provide you with technical support solutions faster.



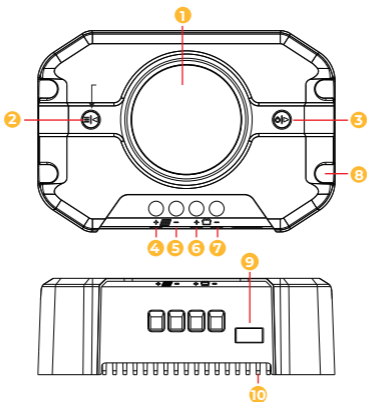

- (1)The connection method of the solar panels (series/parallel, quantity, voltage, power).
- (2)The voltage and battery type of the battery.
- (3)The pictures or videos of the controller: battery voltage, battery charging current, the output voltage of the solar panel.













Identification Of Parts



- 1 LCD Backlit Display Screen
- 2 Menu Button (switch menu/adjust parameters)
- 3 Switch Button (control USB/adjust parameters)
- 4 PV Positive Terminal
- 5 PV Negative Terminal
- 6 Battery Positive Terminal
- 7 Battery Negative Terminal
- 8 Installation Mounting Holes
- 9 USB Output Port
- 10 Heat Sink

LCD Display Interface Overview

Display Section	Status
Charge And USB Status	
Parameter	
BAT Type	
Indicate And Warning	

Status Icon	Indication	Status	Description
	Day Night And Charge Indication	 On	Daylight Detected
		 On	No Daylight Detected
		 On	Solar Charging Battery
	Battery Indication		Battery Voltage is High
			Battery Voltage is Middle
			Battery Voltage is Low
	USB Indication	 On	USB On
		 Off	USB Off
	System Error Indication	On	System Error - Check Error Code
		OFF	System Normally
	Voltage Indication	12V	12V System Voltage
		24V	24V System Voltage

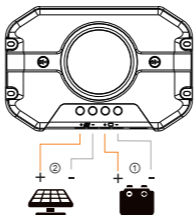

1. The positive and negative poles of the battery must be connected to the battery terminals of the controller first.
2. Finally, connect the positive and negative poles of the solar panel to the PV terminals of the controller.

Note: Please strictly follow the above sequence for connection, otherwise the controller may be damaged. The disassembly sequence is opposite to the wiring one.

Caution

1. First make sure your battery system is 12V or 24V.
2. Ensure that the maximum open-circuit voltage of the solar system does not exceed 55V.
3. Ensure that the maximum output current of the solar panel does not exceed rated current. (10A/20A/30A)
4. Ensure that the voltage of the solar panel is higher than the battery voltage.

Wiring Instructions

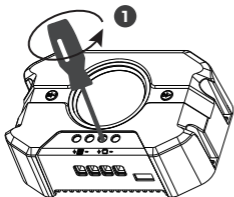

1. Unscrew the screws.
(Counterclockwise)

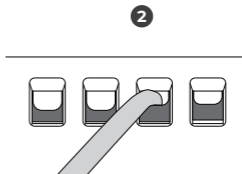

2. Plug the cable into the correct port.

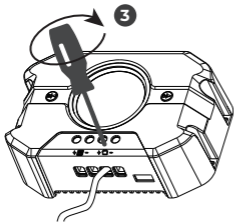

3. Tighten the screws.(Clockwise)

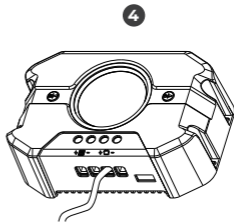



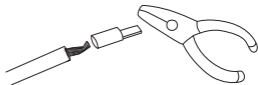

4. Check the wiring condition

Note:

During the wiring process, the attached terminal block can be used for connection. After stripping the wire, put it into the terminal block and squeeze it with a crimping pliers.



Key Operation

Function Key	System Mode	Operate	Function
	View Mode	Long Press (exceed 2s)	Enter SET mode
		Short Press	View Next Page
	View Mode	Long Press (exceed 2s)	N/A
		Short Press	Switch USB On/Off
	Set Mode	Long Press (exceed 2s)	N/A
		Short Press	Adjust parameter(Dec)
	Set Mode	Long Press (exceed 2s)	Save Data & Exit SET Mode
		Short Press	Adjust parameter(Add)

Keep Down  , Long press  exceed 10s, Show F01 to restore factory settings.

LCD Display Interface

Main Menu Interface



The displayed value is the actual voltage of the battery.

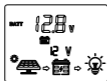

Battery charging voltage

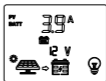
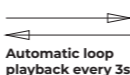

Battery charging current

Menu 1: Battery type setting

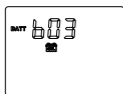

- ① b01=Sealed Lead Acid battery (SEL)
- ② b02=Absorbed Glass Mat battery (AGM)
- ③ b03=GEL battery (GEL)
- ④ b04=Flooded Lead Acid battery (FLD)
- ⑤ b05=LiFePO4 (LFP)
- ⑥ b06=Ternary lithium battery (LI)
- ⑦ b07=Lithium-Titanium-Oxide (LTO)

Setting method



In the view mode, short press **A** to jump to the menu interface, long press **A** for more than 2s until the parameter flashes, short press **A**, **B** to adjust, after finishing the adjustment, long press **B** for more than 2s to confirm the parameter.

Short press **A** to jump to other interface or wait for 15s without operation it would automatically jump to the main menu interface.

Menu 2: System voltage setting interface



- ① Automatically identify voltage (only applicable to the lead-acid battery);
- ② 12V battery;
- ③ 24V battery

Setting method: Same as above.

Note: When the battery type is set to lead-acid battery **b01-b04**, the system automatically recognizes the battery voltage by default. When it is set to **b05-b07**, the system defaults to 12V, and the voltage needs to be adjusted manually)

Menu 3: Lithium battery charging voltage setting



Setting method: Same as above.

Note: This setting menu interface will only appear when the battery type is set to **b05-b07**. Please manually adjust it according to your own lithium battery charging voltage (the adjustment voltage range is 11V-15V). The system default value refers to the battery charge parameter.

Menu 4: Display the current controller temperature



①°F; ②°C

Setting method: Same as above.

Note: The system defaults to °F.

Menu 5: Display solar panel output voltage

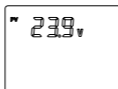





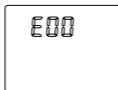



Note: The voltage value only can be read, but cannot be adjusted; this voltage is the output voltage of the solar panel. In PWM working mode, this voltage will be automatically adjusted to be the same as the battery charging voltage, and the open-circuit voltage of the solar panel will be displayed when not charging;

Menu 6: Error Code



Error Code

Error code	Cause of failure	Solution
	Normal.	/
	Battery voltage is too low.	Check if the system voltage is set correctly or turn off the load and continue charging until the battery voltage reaches the recovery voltage.
	Battery voltage has exceeded the controller limit.	Check if the system voltage is set correctly.
	The output current of the solar panel exceeds the rated current of the controller.	Reduce the power of the solar panel system.
	The controller is below the limit temperature (-20°C/-4°F).	Place the controller in a suitable temperature environment.
	The controller exceeds operating temperature limit(80°C/176°F).	Ensure the controller is placed in a well-ventilated cool, dry environment.
	The input voltage of the solar panel exceeds 55V.	Reduce the voltage of the solar panel system and the voltage is lower than 55V to recover.
	The positive and negative connections of the solar panel are reversed.	Disconnect and reconnect with correct wire polarity.
	The positive and negative connections of the battery are reversed.	Disconnect and reconnect with correct wire polarity.

Base Specification

Model	P2410N	P2420N	P2430N
System voltage:	12V/24V		
Rated charging current:	10A	20A	30A
Maximum PV input voltage:	<55V		
Maximum input of PV system:	150W/12V 300W/24V	300W/12V 600W/24V	450W/12V 900W/24V
Screen dimensions:	1.57*1.18inch (40*30 mm)		
Screen type:	Black&White	Color	Color
Backlight display time:	15s off without operation		
No-load loss:	8ma (12V), 12ma (24V)		
Working temperature:	-31°F ~ 113°F (-35°C ~ +45°C)		
Protection level:	IP32		
Altitude:	≤3000m		
Net weight:	0.3 lb (155g)	0.4 lb (185g)	0.8 lb(370g)
Dimensions: (inch)	4.72*3.53*1.27	5.51*3.74*1.27	5.92*3.95*1.92
Drill Hole Size: (inch)	0.12*0.07		

Battery Charge Parameter

Battery Types	SEL	AGM	GEL	FLD	LFP	LI	LTO
Boost Charge Voltage	14.4V*n	14.4V*n	14.2V*n	14.6V*n	14.6V*n	12.4V*n	13.4V*n
Equalizing Charge Voltage	14.6V*n	14.4V*n	-	14.8V*n	-	-	-
Floating Charge Voltage	13.8V*n				-	-	-
Boost Charge Return Voltage	13.2V*n				-	-	-
Boost Charge Time	2 hour	2 hour	2 hour	2 hour	-	-	-
Equalization Charge Time	2 hour	2 hour	-	2 hour	-	-	-
Equalizing Charge Interval	30 day	30 day	-	30 day	-	-	-

Note:

- ① n=1 for 12V system; n=2 for 24V system;
- ② The parameters corresponding to the yellow font can be modified (adjust range is 11-15V *n) and the other parameters cannot be modified.

Controller Dimension

P2410N

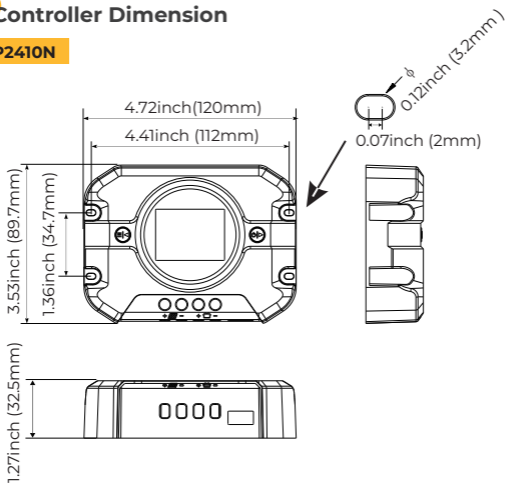

- Product Dimension:** 4.72*3.53*1.27 inch (120*89.7*32.5mm)
- Installation Area Dimension:** 4.41*1.36 inch (112*34.7mm)
- Drill Hole Size :** 0.12*0.07 inch (3.2*2mm)
- Installation Hole size :** 0.19*0.29 inch (5*7.5mm)

P2420N

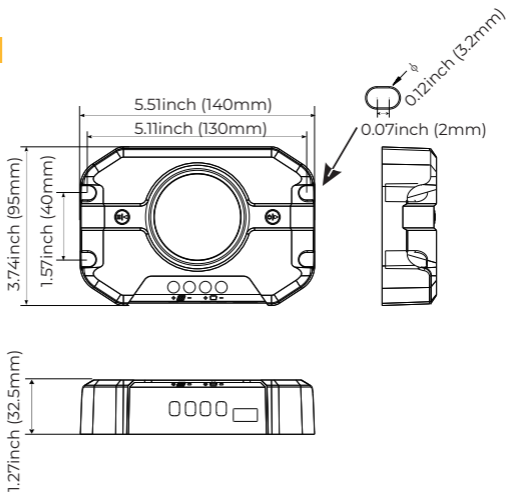

- Product Dimension :** 5.51*3.74*1.27 inch (140*95*32.5mm)
- Installation Area Dimension :** 5.11*1.57 inch (130*40mm)
- Drill Hole Size :** 0.12*0.07 inch (3.2*2mm)
- Installation Hole size :** 0.19*0.29 inch (5*7.5mm)

P2430N

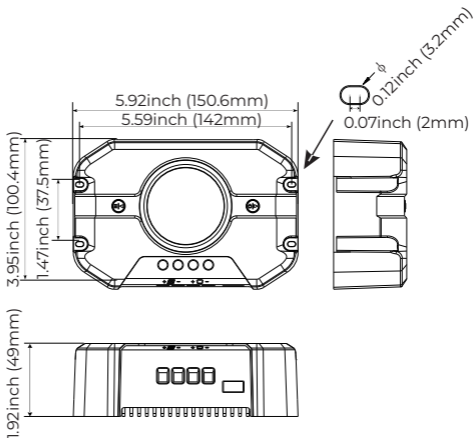

- Product Dimension:** 5.92*3.95*1.92 inch (150.6*100.4*49mm)
- Installation Area Dimension:** 5.59*1.47 inch (142*37.5mm)
- Drill Hole Size :** 0.12*0.07 inch (3.2*2mm)
- Installation Hole Size :** 0.29*0.39 inch (7.5*10mm)

Lead-acid Battery Working Stage

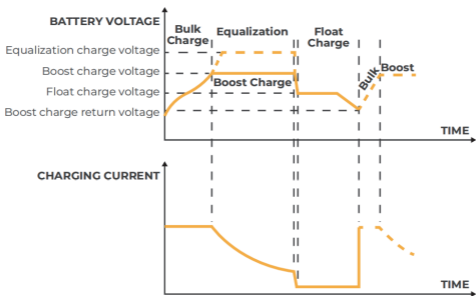

- 1 Bulk Charge:** Constant current charging, providing the maximum current to the battery until the battery voltage reaches the constant voltage stage (boost charging voltage or equalize charging voltage).
- 2 Boost Charge:** Constant voltage charging, the battery is charged for 120 minutes at an elevated charging voltage.
- 3 Float Charge:** After the boost charge, the controller will reduce the battery voltage by reducing the charging current, and let the battery voltage be maintained at the set value of the float charging voltage. During the float charging stage, the battery is charged very slightly to ensure that the battery is maintained in a fully charged state. In the float charging stage, the load can obtain nearly all solar power. If the load exceeds the power that solar energy can provide, the controller will not be able to maintain the battery voltage at the float charging stage. When the battery voltage is low to the set value of boost charge return voltage, the system will exit the float charging stage and enter the bulk charging stage again.

4 Equalization: Equalization charging raises the battery voltage to higher than the standard supplementary voltage to charge the battery. Certain types of lead-acid batteries benefit from regular equalization charging, which can agitate the electrolyte, balance the battery voltage, complete a chemical reaction, and prevent battery vulcanization.

Note: Only FLD, SLD and AGM can perform equalization charging. The equalization charge will be carried out every 30 days, and the charge time is 120 minutes. When the battery is charged in equalization, the boost charge stage will not be performed.

Lithium Battery Working Stage

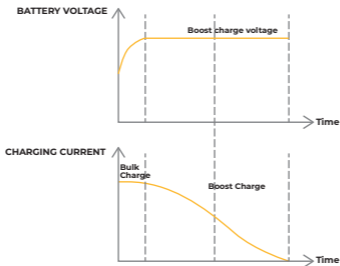

① Bulk Charge: Constant current charging, providing the maximum current to the battery until the battery reaches the boost charge voltage.

② Boost Charge: Charge with a constant voltage. When it is about to be fully charged, the charging current starts to drop, and finally charges with a small current. During this process, the charging voltage is constant to maintain the boost charge voltage.

Frequently Asked Questions

Q1: When I have some problems in the process of using the controller, what information can I provide to BougeRV to provide me with technical support faster and better?

A1: Send the following information to the email: service@bouger.com,
①The connection method of the solar panels (series/parallel, quantity, voltage, power). ②The voltage and battery type of the battery. ③The display data of the controller: battery voltage, battery charging current, the output voltage of the solar panel. ④Connection from solar panel to controller and controller to the solar panel.

If the above information can be provided with pictures or videos, BougeRV can provide you with technical support faster.

Q2: Why the battery is not charging?

A2: There may be the following reasons: the solar panel cable is connected reversely, the output voltage of the solar panel is lower than the battery voltage, and the output voltage of the solar panel is greater than the maximum PV input voltage. ①Check if the cable from the PV terminal to the controller is correct. ②Check the output voltage of the solar panel. If the output voltage of the solar panel is lower than the battery voltage, you need to connect the solar panels in series to increase the voltage; if the output voltage of the solar panel is higher than 55 Voc, you need to reduce the output of the solar panel.

Q3: Why does the controller display a very low output current?

A3: The output current may be low due to weak light or shadows of solar panels. ②The battery may enter other charge stages except for the buck charge and therefore the current drops. You can use a multimeter to check the battery voltage to determine which charging stage the battery is in.

Q4: What do I need to pay attention to when using the controller on a daily basis?

A4: ①Ensure that the system voltage and battery type of the controller are set correctly. ②The controller should be installed as close to the battery as possible to avoid the voltage drop caused by too long wires, which will affect the normal voltage judgment. ③The controller should be installed in a well-ventilated, non-humid environment.

Q5: If you have any questions you can feel free to contact us:

 service@bougerv.com

 1-669-232-7427

 www.bougerv.com



1-669-232-7427



BougeRV

Limitless Energy, Limitless Life.



www.bougeRV.com