

# DENON<sup>®</sup>

## DP-450USB

TURNTABLE

# Owner's Manual

Front panel

Rear panel



|                                 |    |
|---------------------------------|----|
| <b>Accessories</b>              | 4  |
| <b>Features</b>                 | 5  |
| <b>Part names and functions</b> | 7  |
| Front panel                     | 7  |
| Rear panel                      | 10 |

## Preparations

|  |    |
|--|----|
| <b>Assembly</b>                        | 12 |
| Mounting the turntable                 | 13 |
| Mounting the counterweight             | 14 |
| Mounting the head shell with cartridge | 14 |
| Attaching the dust cover               | 15 |
| Using the dust cover as a record stand | 15 |
| <b>Adjustments</b>                     | 17 |
| Adjusting the stylus pressure          | 17 |
| Adjusting anti-skating                 | 19 |

## Connections

|  |    |
|--|----|
| <b>Connecting devices that do not have a phono input</b> | 21 |
| <b>Connecting devices that have a phono input</b>        | 22 |
| <b>Connecting the AC adapter</b>                         | 23 |

## Playback and recording

|   |    |
|---|----|
| <b>Record playback</b>  | 26 |
| Record playback   | 26 |
| Stopping playback   | 28 |
| Using the automatic stop function                                       | 29 |
| <b>Recording to a USB memory device</b>                                 | 30 |
| Recording to a USB memory device  | 31 |
| <b>Installing the “MusiCut for DENON” digital file editing software</b> | 32 |



## Tips

|  |           |
|--|-----------|
| <b>Contents</b>                                      | <b>33</b> |
| <b>Troubleshooting</b>                               | <b>34</b> |
| Power does not turn on/Power is turned off           | 35        |
| The turntable does not spin                          | 35        |
| No sound comes out                                   | 36        |
| Audio skips, scratches or is distorted               | 36        |
| Howling is produced                                  | 37        |
| The tone arm stops moving halfway                    | 37        |
| Audio cannot be recorded to the USB memory device    | 38        |
| Cannot install "MusiCut for DENON" onto the computer | 38        |

## Appendix







|                             |           |
|-----------------------------|-----------|
| <b>Replacing the stylus</b> | <b>39</b> |
| <b>Specifications</b>       | <b>40</b> |

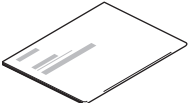
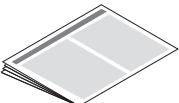
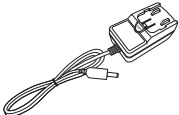
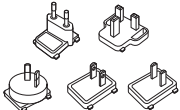

Thank you for purchasing this Denon product. To ensure proper operation, please read this owner's manual carefully before using the product. After reading this manual, be sure to keep it for future reference.

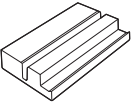
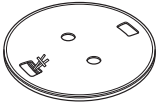
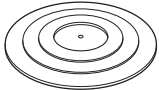
## Accessories

Check that the following parts are supplied with the product.

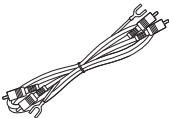
|  |  |   |  |
|--|--|---|--|
|  <p>Quick Start Guide</p> |  <p>Safety Instructions</p>       |  <p>AC adapter</p>    |  <p>AC adapter plugs<br/>(5 pieces)</p> |
|  <p>Dust cover</p>        |  <p>Dust cover stand</p>          |  <p>Turntable</p>     |  <p>Turntable sheet</p>                 |
|  <p>45 rpm adaptor</p>    |  <p>Head shell with cartridge</p> |  <p>Counterweight</p> |  <p>Audio cable</p>                     |

## Features

---

- **Converting analog audio from records to digital formats and saving to a USB memory device**

Analog audio can be converted to a digital format (44.1 kHz/192 kbps MP3 or 44.1 kHz/16 bit WAV) and saved to a USB memory device. This audio can then be played back on any device that supports playback from a USB memory device.

- **Digital files saved to a USB memory device can be split up, song information acquired and file names edited using the supported “MusiCut™ for DENON” software (MP3 only)**

Space in between songs (silence) can be searched for manually or detected automatically to split up the file, track numbers can be assigned to each song and song information can be acquired from the Gracenote audio database. For access, download software from our website for use on your computer.

- **Modern design**

Much like the PMA-60, DRA-100 and other devices in our Denon Design Series, all unnecessary decoration has been eliminated for an updated minimalistic design.

- **The automatic arm lifter function automatically raises the tone arm at the end of record playback**

- **Stabilizing rotation control improves rotation precision**

A sensor has been installed that measures the RPM to maintain a precise rotation speed.

- **An MM cartridge is pre-attached to the headshell to enable immediate use without assembly**

- **Equipped with an equalizer switch to turn the built-in phono equalizer on and off**

The phono equalizer is built in to enable direct connection, even if the amplifier or mini component system does not have phono input. Use the switch to turn the equalizer off to enable connection to amplifiers with a phono input.



- **Equipped with a function to switch RPM between 33 1/3, 45 and 78**

Change record playback speed between 33 1/3, 45 and 78 RPM as needed. This means that both 7 inch and 12 inch record playback in all RPM formats is supported.

- **Equipped with a dust cover that can be used as a record stand**

The included dust cover can also be set up for use as a record stand. Use it to display the sleeves of your records.



## Part names and functions

### Front panel

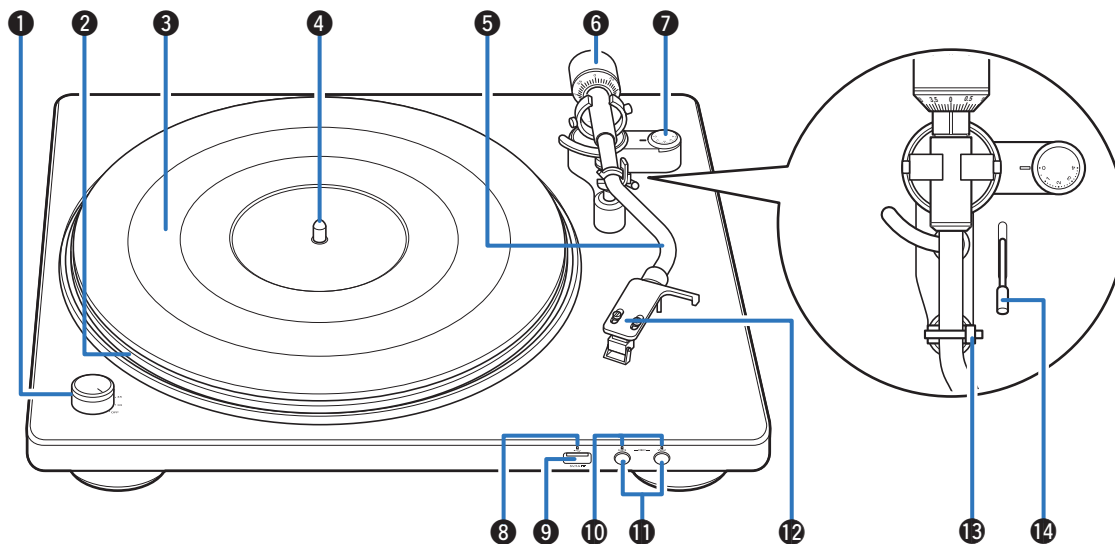

For details, see the next page.

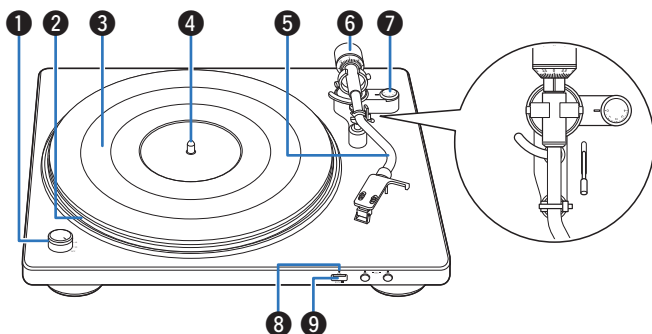

#### 1 Power/rpm switch knob

Turn the power on and off and change the RPM as needed during record playback. (☞ p. 26)

#### 2 Turntable

Attached by mounting on the center spindle on the main unit. The belt is equipped underneath. (☞ p. 13)

#### 3 Turntable sheet

Mounted on top of the turntable. (☞ p. 13)

#### 4 Center spindle

Place the turntable and records so that it comes out through the center.

#### 5 Tone arm

- The counterweight is mounted on the back. (☞ p. 14)
- The head shell with cartridge is attached to the tip. (☞ p. 14)

#### 6 Counterweight

Attached to the back of the tone arm to adjust stylus pressure.

- “Mounting the counterweight” (☞ p. 14)
- “Adjusting the stylus pressure” (☞ p. 17)

#### 7 Anti-skating dial

Adjusts anti-skating. (☞ p. 19)

#### 8 USB indicator

The following indicate the USB recording status. (☞ p. 31)

- White light on: A USB memory device is inserted in the USB port
- White light flashing: Recording to a USB memory device

#### 9 USB port (☞)

Used to insert USB memory devices. (☞ p. 30)



- The device can convert audio played back from analog sources to digital formats (MP3 or WAV) and save to a USB memory device. Saved audio files cannot be played back from a USB memory device.

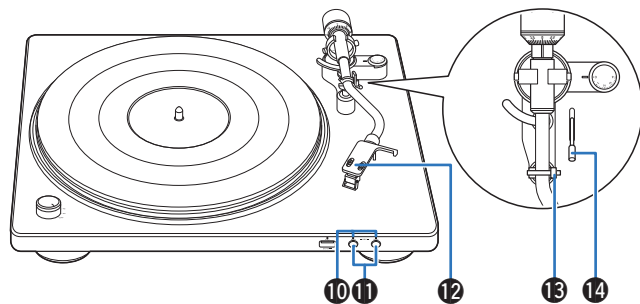

**10 REC MP3/WAV indicators**

Lights in blue after the REC MP3/WAV buttons is pressed to indicate that the device is currently recording audio to USB. (☞ p. 31)

**11 REC MP3/WAV buttons**

Used to select the digital audio format (MP3 or WAV) when recording to USB. Also used to start and stop audio recording. (☞ p. 31)

**12 Head shell with cartridge**

Attached to the tip of the tone arm. (☞ p. 14)

**13 Armrest**

Rest the tone arm here when it is not in use for record playback.

**14 Lifter lever**

Raises and lowers the tone arm. Lowering the lever slowly lowers the tone arm to place the stylus without damaging it or the record to be played.

## Rear panel

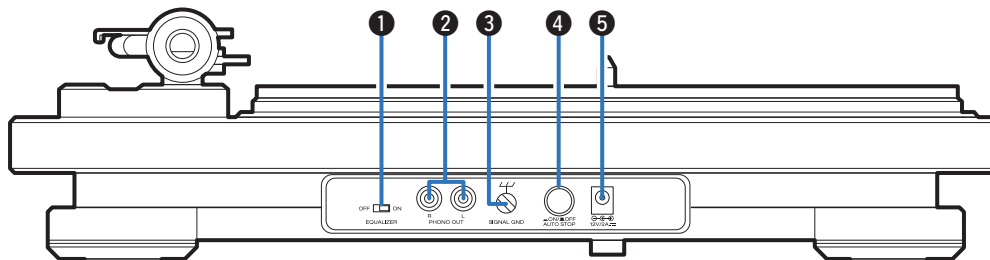

### 1 EQUALIZER ON/OFF switch

This switches the built-in equalizer on and off. Switch as needed depending on whether the connected amplifier or mini component system are equipped with phono input or not.

- “Connecting devices that do not have a phono input” (☞ p. 21)
- “Connecting devices that have a phono input” (☞ p. 22)

### 2 PHONO OUT connectors

For connecting devices with external audio or phono inputs.

- “Connecting devices that do not have a phono input” (☞ p. 21)
- “Connecting devices that have a phono input” (☞ p. 22)

### 3 SIGNAL GND terminal

Use the grounding wire on the supplied audio cable, even when connecting this device to amplifiers with grounded connections. (☞ p. 22)

### 4 AUTO STOP ON/OFF button

Automatically raises the tone arm and stops the turntable at the end of a record when this function is on during record playback. (☞ p. 29)

### 5 AC adapter input connector

For connecting the included AC adapter. (☞ p. 23)

## ■ Contents

### Assembly

---

|  |    |
|--|----|
| Mounting the turntable                 | 13 |
| Mounting the counterweight             | 14 |
| Mounting the head shell with cartridge | 14 |
| Attaching the dust cover               | 15 |
| Using the dust cover as a record stand | 15 |

### Adjustments

---

|                               |    |
|-------------------------------|----|
| Adjusting the stylus pressure | 17 |
| Adjusting anti-skating        | 19 |



# Assembly

Mount these included parts on the main unit before use.

Make sure to perform setup on a stable, even surface to prevent the influence of vibration or slanted angles on record playback.

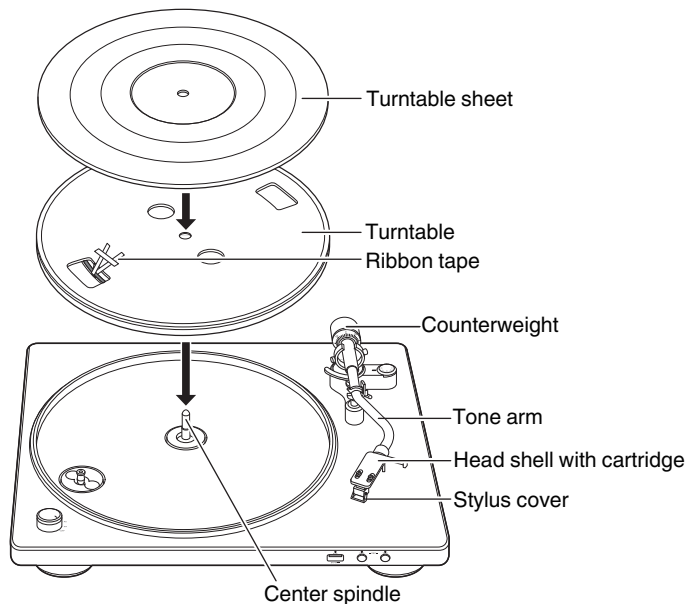

## NOTE

- Make sure the AC adapter is not connected from this unit to a wall socket during assembly.

## Mounting the turntable

- 1** Mount the hole in the center of the turntable on the center spindle.
- 2** Turn the turntable until the roller of the main unit is visible from the square hole on the side with the ribbon tape.

### **3** Pull out the ribbon tape, and hang the belt on the roller.

- Remove the ribbon tape after hanging the belt.

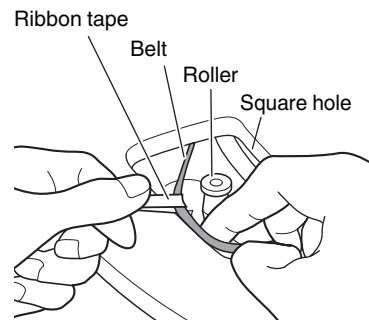

- Take care not to twist the belt when hanging it.
- Store the ribbon tape after use, as it is required when replacing the belt.

### **4** Mount the turntable sheet on the turntable.



- Mount the sheet with the side featuring the DENON logo facing down.

## Mounting the counterweight

- 1 Insert the counterweight into the shaft on the back of the tone arm, and turn it in the direction of the arrow while gently pushing it.

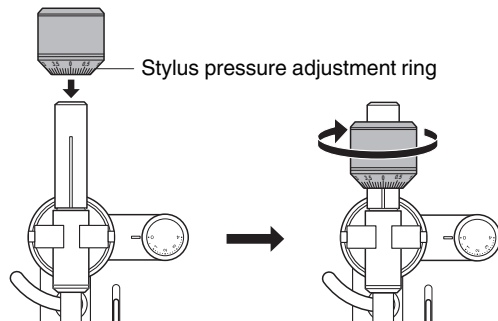

- Mount the counterweight so that its stylus pressure adjustment ring is facing the front.

## Mounting the head shell with cartridge

- 1 Insert the head shell into the tip of the tone arm.
  - Insert the head shell with its guide pin facing up and aligned with the hole on the top of the tone arm.

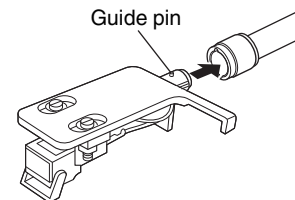

- 2 Turn the lock nut in the direction of the arrow to secure the head shell.

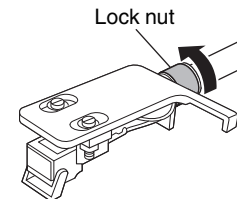

### NOTE

- Perform this operation with the stylus cover of the cartridge lowered to protect the stylus tip.

## Attaching the dust cover

- 1 Mount the hole on the dust cover on the center spindle.

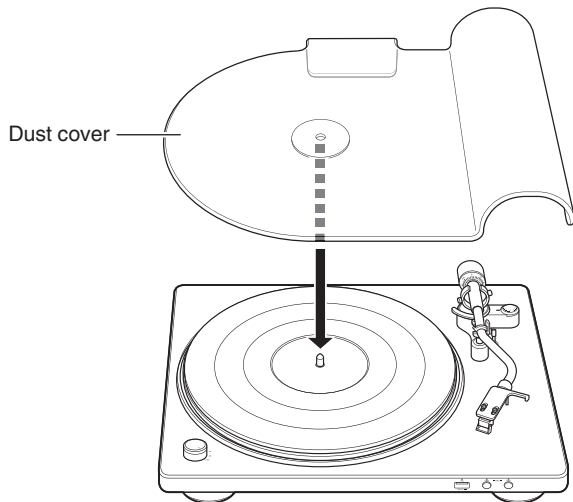

- Remove the dust cover before record playback.

## Using the dust cover as a record stand

Attach the dust cover to the included dust cover stand to use it as a record stand. Use it in this way when it is not attached to the main unit.

- 1 Face the dust cover as shown in the picture below to insert it into the groove in the dust cover stand.

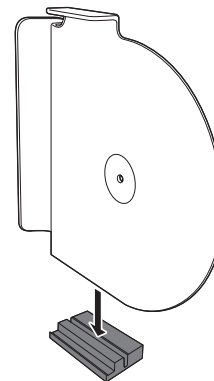

- 2** Record sleeves can be fitted into the indent on the dust cover stand and leaned against the dust cover.

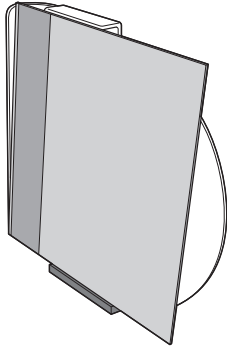

# Adjustments

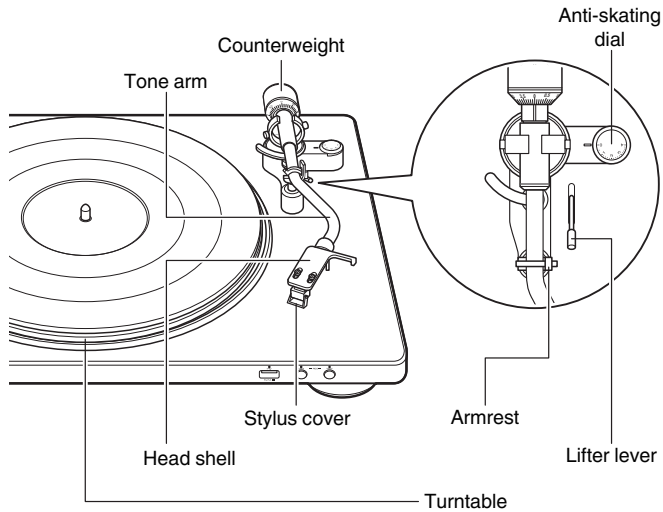

## Adjusting the stylus pressure

To enable the record stylus to follow the grooves of the record and pick up sound (vibrations), it is necessary to apply a constant pressure (stylus pressure) to the record from the stylus tip. A suitable stylus pressure value is specified for each cartridge. If the stylus pressure is higher or lower than the specified value, not only will the record playback sound be distorted and the stylus jump, but the record stylus may wear out faster and the record may become damaged. Therefore, make sure to adjust the stylus pressure to the suitable value.

### 1 Set the anti-skating dial to "0".

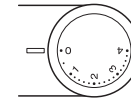

### 2 Lower the lifter lever.

#### NOTE

- Make sure the AC adapter is not connected from this unit to a wall socket when performing adjustments.

### 3 Release the armrest lock.

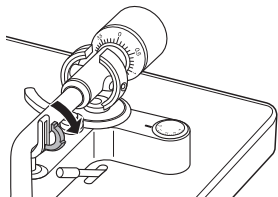

### 4 Holding the finger lift of the headshell, move the tone arm over the turntable.

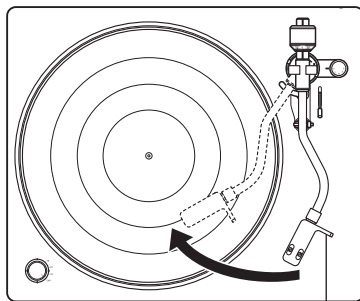

Finger lift

#### NOTE

- Perform this operation with the stylus cover of the cartridge lowered to protect the stylus tip.

### 5 Turn twist the counterweight so that the tone arm is floating parallel to the turntable.

- Perform adjustment by turning the counterweight gradually while periodically removing your hand to check the position.

Keep it parallel

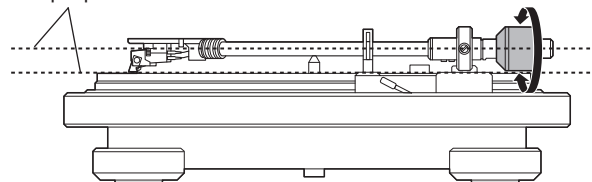

### 6 Return the tone arm to the armrest.

- 7** Holding the counterweight with a finger so that it does not move, turn the stylus pressure adjustment ring so that its “0” mark is lined up with the line on the tone arm.

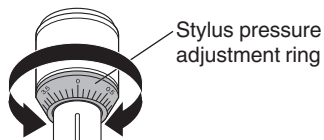

- 8** Turn the counterweight in the direction of the arrow so that the “2” mark of the stylus pressure adjustment ring is lined up with the line on the tone arm.



- The appropriate stylus pressure for the cartridge included with this unit is 2.0 g (19.6 mN).

## Adjusting anti-skating

Anti-skating adjustment is performed to counter the force which pulls the stylus tip inside due to the record rotation.

- 1** Turn the anti-skating dial so that it is lined up with “2”.

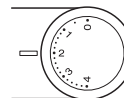

- Make sure that the anti-skating value is the same as the stylus pressure value.

## ■ Contents

|   |    |
|---|----|
| Connecting devices that do not have a phono input | 21 |
| Connecting devices that have a phono input        | 22 |
| Connecting the AC adapter                         | 23 |

### NOTE

- Do not plug in the AC adapter until all connections have been completed.
- Do not bundle AC adapter together with connection cables. Doing so can result in humming or noise.



## Connecting devices that do not have a phono input

This unit has a built-in phono equalizer that enables record playback when connected to devices with external audio input without a built-in phono equalizer or with mini component system. Use the EQUALIZER ON/OFF switch to turn the phono equalizer on this unit “ON” when connected to a device without a built-in phono equalizer.

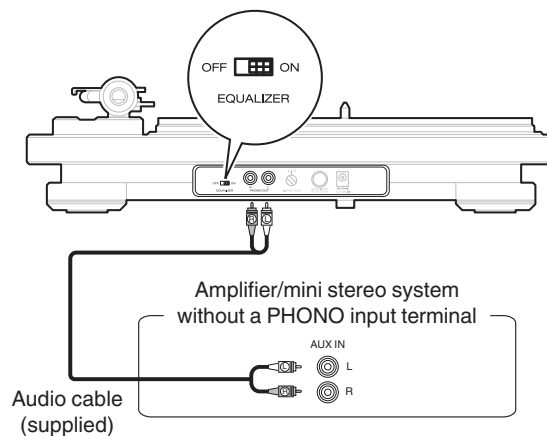

- It is recommended that the earth wire of the included audio cable is kept out of the way by securing it with a tie such as the twist tie of the audio cable.
- If the EQUALIZER ON/OFF switch is not set correctly, audio will be extremely low or distorted.



## Connecting devices that have a phono input

When connected to a device with a built-in phono equalizer, use that device's phono equalizer during record playback. Use the EQUALIZER ON/OFF switch to turn the phono equalizer on this unit "OFF" when connected to a device with a built-in phono equalizer.

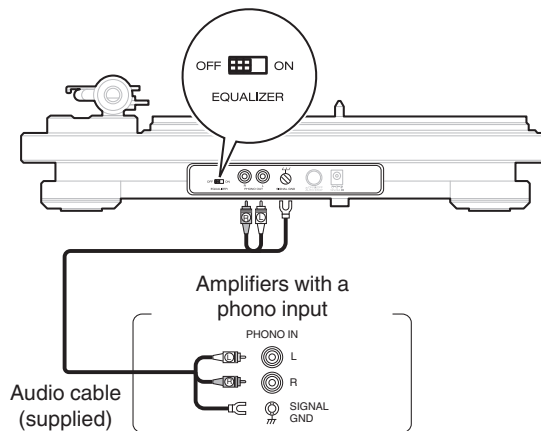

- If a device connected to this unit has an earth terminal, connect the earth wire of the audio cable (supplied) to the earth terminal of this unit (SIGNAL GND). This may reduce noise during playback.
- If the EQUALIZER ON/OFF switch is not set correctly, audio will be extremely low or distorted.



## Connecting the AC adapter

Wait until all connections have been completed before connecting the AC adapter.

Attach the plug needed for your wall outlet as shown in the figure below.

### 【Attaching the AC adapter plug】

1. Insert the nubs on the bottom of the AC adapter plug into the grooves on the AC adapter as shown in the picture below.

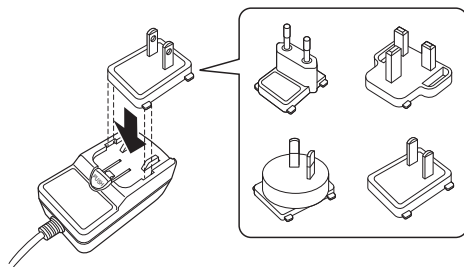

2. Push in the direction of the arrow until it locks in with an audible click.

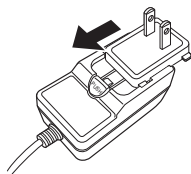

### 【Removing the AC adapter plug】

1. Slide the AC adapter plug out in the direction of the arrow as far as it can go while holding the ① button.

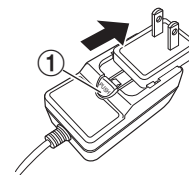

2. Once the AC adapter plug has been slid out as far as possible, lift it up in the direction of the arrow to remove.

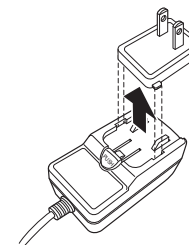

## ■ Connecting the AC adapter

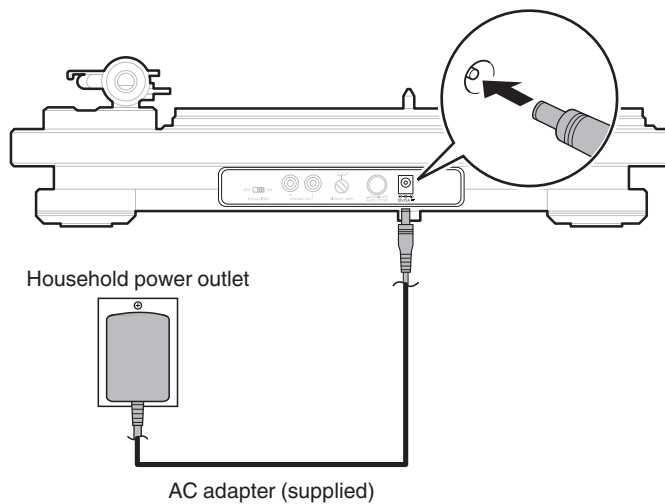

## ■ Contents

|  |    |
|--|----|
| Record playback  | 26 |
| Recording to a USB memory device                                 | 30 |
| Installing the “MusiCut for DENON” digital file editing software | 32 |



# Record playback

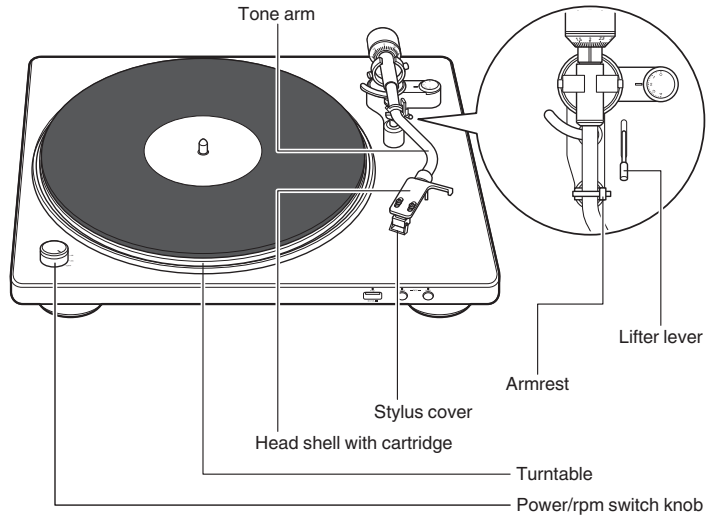

## Record playback

### 1 Place a record on the turntable.



- For EP (“doughnut”) records, insert the included 45 rpm adapter onto the center spindle.

### 2 Turn the power/rpm switch knob to match the turntable rpm with the rpm of the record.

The turntable will start turning.



- You can select 33 1/3, 45, 78 rpm as the turntable speed per minute.
- The record rpm is normally indicated on the jacket or label of the record.

### 3 Raise the stylus cover of the cartridge.

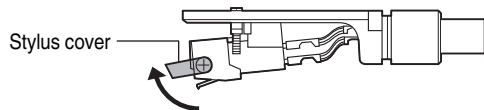

### 4 Release the arm rest lock and raise the lifter lever.

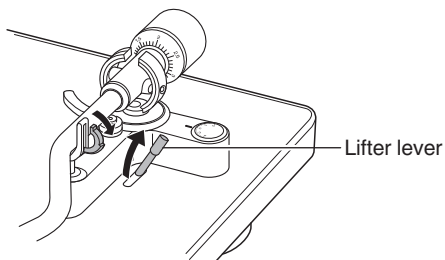

### 5 Grip the finger lift, and move the stylus tip directly above the start position of the track to play.

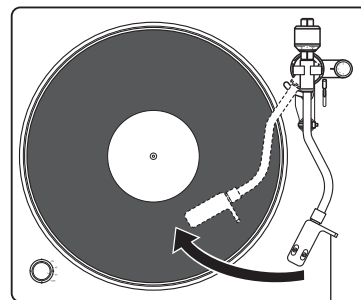

Finger lift

## 6 Lower the lifter lever.

The tone arm slowly lowers, and playback starts when the stylus tip reaches the record.

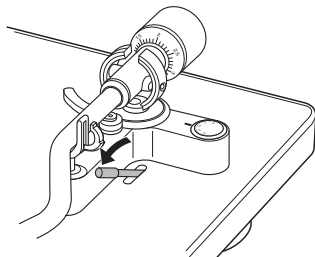

- Be careful not to scratch records.
- Observe the following during playback.
  - Do not touch the tone arm or turntable.
  - Do not disconnect the power.
  - Make sure the device is not subjected to vibration or impact.
- Do not change the record until the turntable has completely stopped.
- Do not apply pressure with your hand to stop the turntable while it is turning. Doing so creates internal heat which can lead to equipment failure or fire.

## Stopping playback

### 1 Raise the lifter lever.

Raise the tone arm to remove the stylus from the record.

### 2 Holding the finger lift of the headshell, return the tone arm to the armrest.

### 3 Lower the lifter lever.

### 4 Lock the tone arm into the armrest.

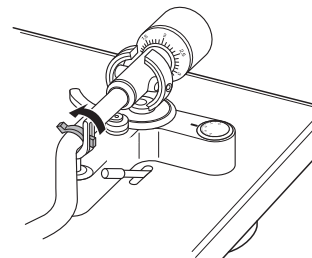

## 5 Turn the power/rpm switch knob to OFF.

The turntable stops.

### NOTE

- Flip down the stylus cover to protect the stylus in the cartridge when this unit is not in use.

## Using the automatic stop function

When automatic stop is on, the tone arm automatically raises after playback and then the turntable stops. This keeps the turntable from continuing to turn and cause stylus wear should you accidentally fall asleep while listening to a record, etc.

- The default setting is on.

### 1 Press AUTO STOP ON/OFF on the rear panel to turn the automatic stop function on.

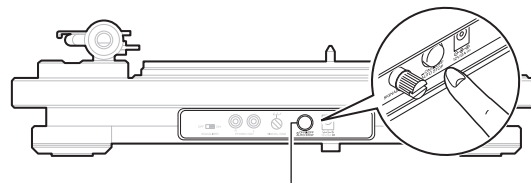

#### AUTO STOP ON/OFF

- Make sure that AUTO STOP ON/OFF is pressed all the way in to make ensure that automatic stop is on.



- The power will turn off approximately 20 minutes after the turntable stops. Use the power/rpm switch knob to restart playback.



## Recording to a USB memory device

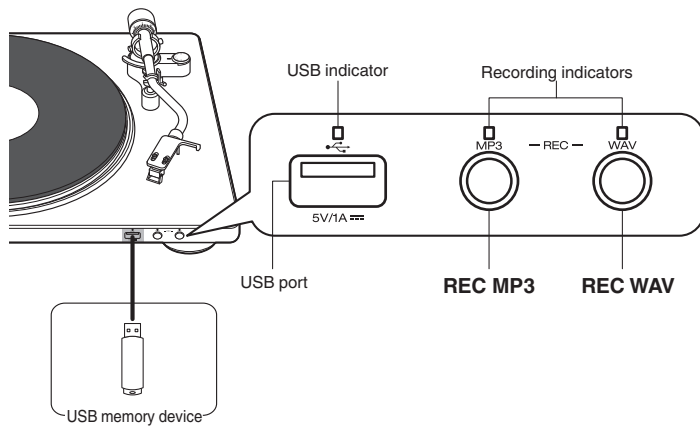

- Audio played back from analog sources can be converted to digital formats and saved to a USB memory device.
- This unit can record to mass storage class-compatible USB memory devices.
- This unit is compatible with USB memory devices in “FAT16” or “FAT32” format.
- The audio format types and specifications supported by this unit for recording are as follows.
  - **MP3** (44.1 kHz/192 kbps)
  - **WAV** (44.1 kHz/16 bit)



- Do not connect USB devices other than flash drives to the USB port.
- USB memory devices will not work via a USB hub.
- Denon does not guarantee that all USB memory devices will operate or receive power.
- It is not possible to use this unit by connecting the unit’s USB port to a PC via a USB cable.
- Write-protected USB memory devices cannot be used.
- Audio cannot be recorded to external hard drives.
- Recording cannot be performed via USB cables (including extension cables).
- The USB port of this unit conforms to “Universal Serial Bus Specification Rev.2.0”.

**In accordance with copyright laws, recordings you have made should only be used for your personal enjoyment and may not be used in other ways without permission of the copyright holder.**



## Recording to a USB memory device

Prepare the record you want to record to a USB memory device in advance.

### 1 Insert the USB memory device into the USB port.

The USB indicator lights up in white.

### 2 Lower the stylus to a silent part of the record for recording.

### 3 Before playback starts, press REC MP3 or REC WAV to set the recording format.

The USB indicator flashes in white and recording starts.



- A blue light indicates that an audio file is being recorded.

### 4 Once recording is over, once again press the same button you pressed in step 3.

The recording indicator goes out and recording stops.



- If the USB memory device has a lock switch to prevent writing, release the lock before recording.
- A single file is created on the USB memory device for a single recording operation (recording start to finish).

#### NOTE

- Do not remove the USB memory device during recording. Audio will not be recorded correctly if the USB memory device is removed during recording. Stop recording before removing the USB memory device.
- Recording stops and the indicator turns off if the USB memory device runs out of free space during recording.
- Recording does not stop automatically when record playback ends. Press REC MP3 or REC WAV to stop recording.
- The volume level on audio recorded to USB memory device cannot be adjusted. Instead, adjust the volume on the playback device before playback starts.
- Note that Denon will accept no responsibility whatsoever for any problems arising with the data on a USB memory device when using this unit in conjunction with the USB memory device.



## Installing the “MusiCut for DENON” digital file editing software

You can install “MusiCut for DENON” of the digital file editing software on your computer from our website. Using “MusiCut for DENON”, digital files saved to a USB memory device can be split up, song information acquired and file names edited (MP3 only).

- MusiCut is the trademark of TrackSafe, Inc.
- Microsoft, Windows 8, Windows 8.1 and Windows 10 are either registered trademarks or trademarks of Microsoft Corporation in the United States and/or other countries.

### ■ Recommended devices and system requirements for using “MusiCut for DENON”

#### OS

- Windows 8, Windows 8.1 or Windows 10

#### HDD

- HDD with 50 MB or more free space

#### USB

- USB 2.0: USB High speed

### ■ Installing “MusiCut for DENON”

- 1 Download “MusiCut for DENON” to your computer from “Downloads” on the DP-450USB page on our website.**
- 2 Unzip the downloaded file, and double-click the exe file.**  
The installation setup screen is displayed.
- 3 Follow the instructions on the setup screen to install.**

### ■ Editing with “MusiCut for DENON”

See “Help” in “MusiCut for DENON” for editing operations.



# Contents

---

## ■ Troubleshooting

|  |    |
|--|----|
| Power does not turn on/Power is turned off           | 35 |
| The turntable does not spin                          | 35 |
| No sound comes out                                   | 36 |
| Audio skips, scratches or is distorted               | 36 |
| Howling is produced                                  | 37 |
| The tone arm stops moving halfway                    | 37 |
| Audio cannot be recorded to the USB memory device    | 38 |
| Cannot install “MusiCut for DENON” onto the computer | 38 |



# Troubleshooting

---

If a problem should arise, first check the following:

1. Are the connections correct?
2. Is the set being operated as described in the owner's manual?
3. Are the other devices operating properly?

If this unit does not operate properly, check the corresponding symptoms in this section.

If the symptoms do not match any of those described here, consult your dealer as it could be due to a fault in this unit. In this case, disconnect the power immediately and contact the store where you purchased this unit.



## Power does not turn on/Power is turned off

### Power is not turned on.

- Check whether the power plug is correctly inserted into the power outlet. (👉 p. 24)
- The power is off. Turn the power/rpm switch knob to the appropriate setting for the record you want to play. (👉 p. 26)

### Power automatically turns off.

- Automatic stop is on. Press the AUTO STOP ON/OFF button on the rear panel to turn the automatic stop function off. (👉 p. 29)

## The turntable does not spin

### The turntable does not spin.

- Check whether the power plug is correctly inserted into the power outlet. (👉 p. 24)
- Make sure that the belt is hooked on both the turntable and roller correctly. Follow the following steps if the belt has come off.
  1. Take the turntable off the main unit and turn it over.
  2. Hook the belt around the outside edge of the circular part on the bottom of the turntable.
  3. Turn the turntable right-side up and pass the ribbon from the square hole between the turntable and the belt.
  4. Set up the turntable as shown in "Mounting the turntable" (👉 p. 13).



## No sound comes out

### No sound is produced. Or sound is distorted.

- Check the connections for all devices. (🔗 p. 20)
- Insert connection cables all the way in.
- Check that input connectors and output connectors are not reversely connected.
- Check cables for damage.
- Check the amplifier's functions and controls and adjust as necessary.
- Make sure the stylus is correctly attached. (🔗 p. 39)
- If connecting an amplifier, mini component system, etc. with no built-in phono equalizer to this unit, set the EQUALIZER ON/OFF switch of this unit to "ON". (🔗 p. 21)

## Audio skips, scratches or is distorted

### Audio skips, scratches or is distorted.

- The correct stylus pressure is not applied. Adjust to the correct pressure. (🔗 p. 17)
- Make sure there are no scratches on the record.
- Make sure the record is not warped.
- Make sure there is no dirt or dust on the stylus or the record.
- Make sure the stylus has not been worn down. Replace the stylus if necessary. (🔗 p. 39)



## Howling is produced

### Howling is produced.

- This unit and speaker are too close together. Move the speaker away from this unit.
- This unit is in an unstable position. Install in a stable, level location.
- Playback volume is too loud. Adjust the volume of the connected amplifier to the appropriate level.

## The tone arm stops moving halfway

### The tone arm not tracking during playback.

- Make sure there are no scratches on the record.
- Make sure nothing is obstructing the tone arm.



## Audio cannot be recorded to the USB memory device

### USB memory device is not recognized.

- Disconnect and reconnect the USB memory device. (👉 p. 30)
- This unit does not support a connection through a USB hub. Connect the USB memory device directly to the USB port.
- Not all USB memory devices are guaranteed to work. Some USB memory devices are not recognized.
- Make sure there is free space on the USB memory device.

### Audio is not recorded to the USB memory device.

- Disconnect and reconnect the USB memory device.
- Make sure there is free space on the USB memory device.
- Audio will not be recorded correctly if the USB memory device is removed during recording. Press the REC MP3 or REC WAV button to stop recording before removing the USB memory device. (👉 p. 31)
- The USB memory device is incompatible with this device.

### Cannot format the USB memory device.

- This unit cannot format USB memory devices. Format USB memory devices on your computer.

## Cannot install “MusiCut for DENON” onto the computer

### Cannot install “MusiCut for DENON” onto the computer.

- Make sure your computer is connected to the internet.
- Make sure your computer has the correct system requirements for “MusiCut for DENON”. (👉 p. 32)



## Replacing the stylus

The supplied stylus is good for approximately 400 hours of playback. Replace the stylus in a timely fashion to prevent damage to your record collection. When replacing the stylus, make sure to request the DSN-85 for dedicated use with this unit at either the location where you purchased this unit or a local repair shop.

### ■ Removing the stylus

Holding the cartridge in one hand, use your other hand to hold the stylus and pull it down in the direction of arrow ①, then pull the stylus in the direction of arrow ② to remove it.

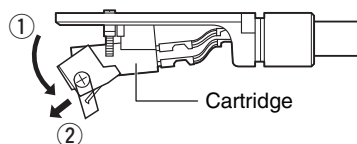

- Make sure this unit and any connected amplifiers are off before replacing the stylus.
- Be very careful when handling the delicate stylus tip. Remove dirt or dust from the stylus tip with a soft brush, etc.
- Replacing the stylus is easier when the headshell is removed from the tone arm.

### ■ Attaching a stylus

Holding the cartridge in one hand, use your other hand to hold the stylus and insert the hooked part of the stylus into the long hole in the cartridge in the direction of arrow ①, then push it up in the direction of arrow ② until it clicks in place.

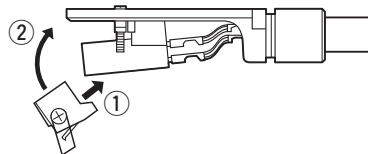

# Specifications

---

## ■ Turntable section

|                |                    |
|----------------|--------------------|
| Drive type:    | Belt drive         |
| Motor:         | DC servo motor     |
| RPM speeds:    | 33 1/3, 45, 78 RPM |
| Wow & flutter: | 0.1% WRMS          |
| S/N ratio:     | 62 dB              |

## ■ Tone arm section

|                              |   |
|------------------------------|---|
| Tone arm:                    | Static balanced type                                      |
| Tone arm effective length:   | 220 mm  |
| Overhang:                    | 16 mm   |
| Stylus pressure range:       | 0 – 4.0 g (0 – 39.2 mN)<br>1 gradation is 0.1 g (0.98 mN) |
| Compatible cartridge weight: | 5.0 – 13.0 g (59.2 mN – 127.5 mN)                         |



## ■ Cartridge section

|   |   |
|---|---|
| <b>Cartridge:</b>                         | MM type                                       |
| <b>Output voltage:</b>                    | Equalizer off: 2.5 mV<br>Equalizer on: 150 mV |
| <b>Optimum stylus pressure:</b>           | 2.0 g (19.6 mN)                               |
| <b>Replacement stylus product number:</b> | DSN-85  |

## ■ USB section

|                  |   |
|------------------|---|
| <b>USB port:</b> | USB recording, type A USB port, version 2.0 |
|------------------|---|

## ■ General

|   |                          |
|---|--------------------------|
| <b>Power supply:</b>                      | AC 100 – 230 V, 50/60 Hz |
| <b>Power consumption:</b>                 | 10 W                     |
| <b>Power consumption in standby mode:</b> | 0.5 W or less *          |

\*When automatic stop function is enabled

For the purpose of improvement, the specifications and design are subject to change without notice.



## ■ Dimensions (Unit : mm)

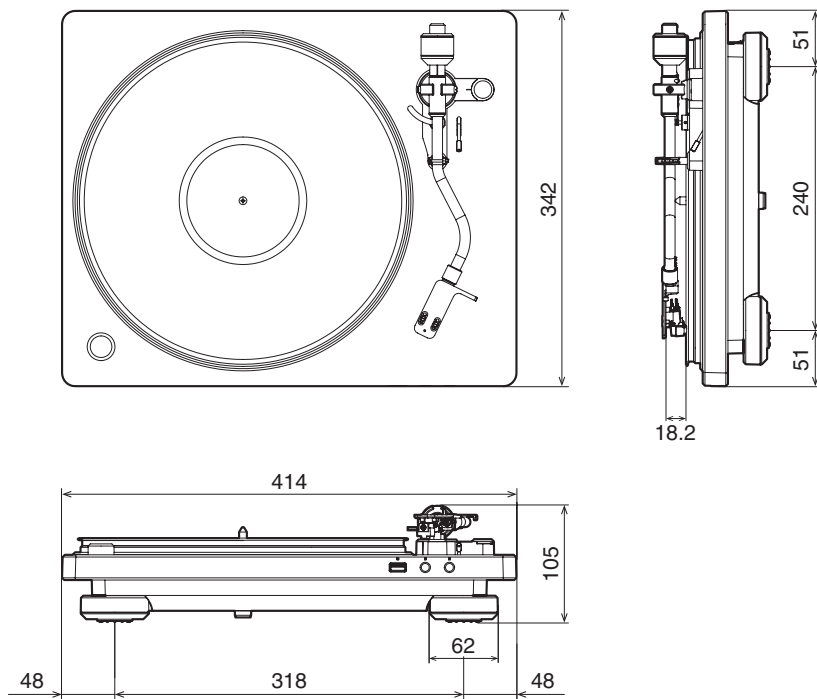

【With dust cover attached】

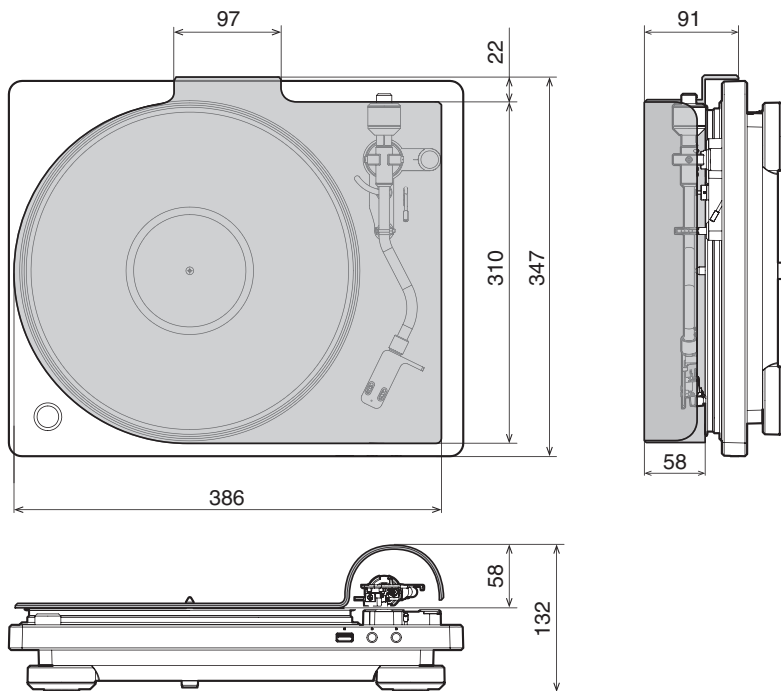

■ Weight: 5.6kg (including the dust cover)

DENON®

[www.denon.com](http://www.denon.com)

3520 10641 00ADA

Copyright ©2018 D&M Holdings Inc. All Rights Reserved.

