

Indirect Plate Water Heater Installation & Service Manual

**Double-Wall Models:
IPW015DW - IPW120DW
Series 100**

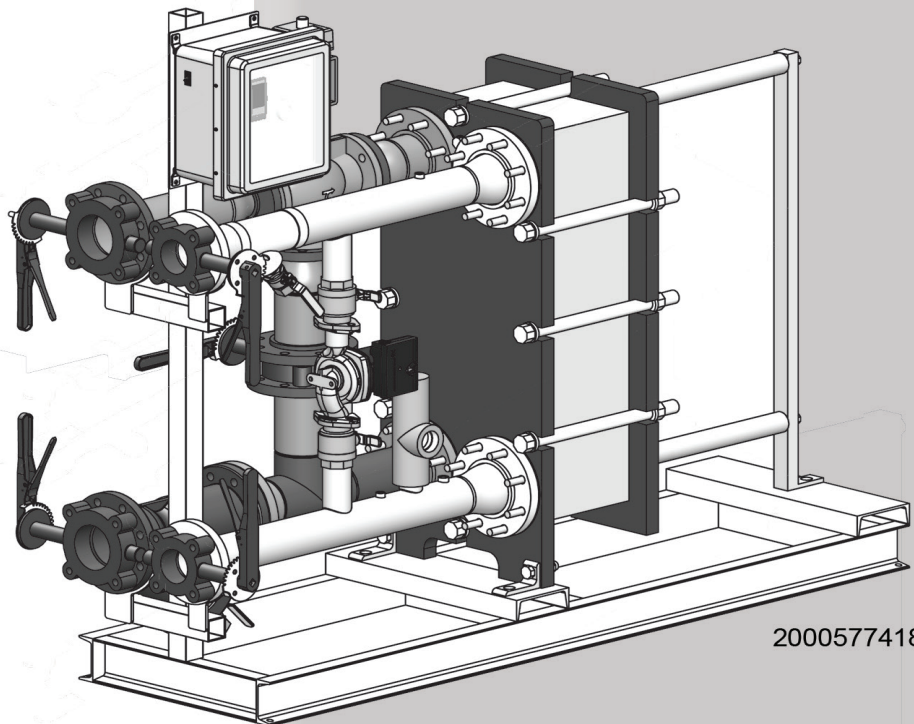

2000577418



LOW LEAD CONTENT



Lochinvar[®]
HIGH EFFICIENCY BOILERS & WATER HEATERS

⚠ WARNING

This manual must only be used by a qualified heating installer / service technician. Read all instructions before installing. Perform steps in the order given. Failure to comply could result in severe personal injury, death, or substantial property damage.

Save this manual for future reference.

Contents

HAZARD DEFINITIONS	2	8. START-UP	
PLEASE READ BEFORE PROCEEDING	3	Introduction.....	25
THE IPW -- HOW IT WORKS	4	Pre-operational checks and procedures	25
1. DETERMINE IPW LOCATION		Initial start-up.....	25
Before locating the appliance, check:	5	Checking mixed inlet temperature	26
Site selection and preparation	5	Shutting down the system.....	26
Installation clearances.....	5	9. MAINTENANCE	
• IPW Water Heater Clearances.....	6	Maintenance and annual startup.....	27
2. PREPARE WATER HEATER		Periodic cleaning of heat exchanger.....	28
Receiving and unpacking the IPW	7	Strainers - inspection and replacement	28
Setting the unit	7	Oiled bearing circulators	28
3. HYDRONIC PIPING		Check water heater relief valve.....	28
IPW piping assemblies.....	8	10. TROUBLESHOOTING	
General piping information	8	• Table 10A - Troubleshooting Chart - No Display	29
Heating fluid and Domestic Hot Water (DHW) piping	8	Checking temperature sensors	30
Scalding.....	8	• Table 10B - Resistance vs. Temperature	30
Hydronic piping illustrations	9-14	11. SIZING DATA	
4. ADJUSTMENTS		How to properly size your Indirect Water Heater.....	31-38
3-Way control valve adjustment.....	15	12. DIAGRAMS	
• Control valve calibration and status indications..	15-16	Wiring Diagram	39
• Manual control of 3-way valve.....	16-17	13. REPLACEMENT PARTS LIST	
Temperature Controller Operating Controls.....	18	When ordering replacement parts.....	40
5. OPERATING INFORMATION		Revision Notes	Back Cover
Sequence of operation	19		
Electronic control overview	19		
Over-temperature control and safety features	19		
6. WIRING			
Electrical wiring connections	20		
7. MODBUS			
Installation procedure.....	21		
ModBus eException Codes.....	22		
Primary Data Tables	23		
Memory Map	23		
Physical Wiring.....	23		
Procedure to change ModBus address.....	24		
Troubleshooting.....	24		

Hazard definitions

The following defined terms are used throughout this manual to bring attention to the presence of hazards of various risk levels or to important information concerning the life of the product.

⚠ DANGER DANGER indicates an imminently hazardous situation which, if not avoided, will result in death or serious injury.

⚠ WARNING WARNING indicates a potentially hazardous situation which, if not avoided, could result in death or serious injury.

⚠ CAUTION CAUTION indicates a potentially hazardous situation which, if not avoided, may result in minor or moderate injury.

CAUTION CAUTION used without the safety alert symbol indicates a potentially hazardous situation which, if not avoided, may result in property damage.

NOTICE NOTICE indicates special instructions on installation, operation, or maintenance that are important but not related to personal injury or property damage.

Please read before proceeding

WARNING

Installer – Read all instructions, including this manual before installing. Perform steps in the order given.

User – This manual is for use only by a qualified heating installer/service technician. Refer to the User's Information Manual for your reference.

Have this Indirect Plate Water Heater (IPW) serviced/inspected by a qualified service technician, at least annually.

Failure to comply with the above could result in severe personal injury, death or substantial property damage.

NOTICE

When calling or writing about the IPW – Please have the IPW model and serial number from the rating label.

Consider piping and installation when determining IPW location.

Any claims for damage or shortage in shipment must be filed immediately against the transportation company by the consignee.

Factory warranty (shipped with unit) does not apply to units improperly installed or improperly operated.

WARNING

Failure to adhere to the guidelines on this page can result in severe personal injury, death, or substantial property damage.

General information –

This instruction manual provides detailed coverage for the Indirect Plate Water Heater (IPW). Each IPW is equipped with an electronic control system specifically designed for an electronic control valve. This control system and valve combination can be used with all models and sizes of IPW water heaters. The IPW is available in the following double-wall heat exchanger models:

• Double-Wall Models

IPW015DW, 030DW, 050DW, 070DW, 090DW, 105DW, and 120DW

A typical packaged IPW water heater with a double-wall heat exchanger is depicted on page 4.

Identical electronic control systems are used on all IPW models. This system contains a control box assembly which includes all of the electronic circuitry for the electronic control system. In addition, the electronic control system includes several sensors and safety devices which provide temperature and flow control information to the control box circuitry. The additional devices included in the electronic control are as follows:

- DHW Inlet Temperature Sensor (RTD)
- DHW Outlet Temperature Sensor (RTD)
- Over-Temperature Switch (With Safety Shutdown)

If desired, the ModBus communication option permits the electronic control system to be externally controlled by an Energy Management System (EMS), Building Automation System (BAS), or computer supplied by other manufacturers.

The IPW - How it works...

1. Control valve

The 3-way electronic control valve is powered by 24 VAC which is received from the electronic control system control box. The temperature controller in the control box supplies a 0 - 10 VDC control signal to precisely modulate the 3-way valve to accurately control the temperature of the DHW output to the desired set point.

2. System water outlet

ANSI flanged connections (2", 3", or 4" depending on model size) with carbon steel piping that returns boiler water back to the system loop.

3. System water inlet

ANSI flanged connections (2", 3", or 4" depending on model size) with carbon steel piping that receives boiler water from the system loop.

4. P & T Relief valve

Protects the heat exchanger from an over pressure condition. The relief valve provided with the unit is set at 150 psi and 210°F.

5. Electronic control system control box

Contains a control box assembly which includes all of the electronic circuitry for the electronic control system. In addition, the electronic control system includes several sensors and safety devices which provide temperature and flow control information to the control box circuitry.

6. DHW inlet

ANSI flanged connections (2" or 3" depending on model size) with stainless steel piping that receives cold water from the DHW piping.

7. DHW outlet

ANSI flanged connections (2" or 3" depending on model size) with stainless steel piping that delivers heated water back to the DHW piping.

8. Recirculation pump

The recirculation pump helps prevent scale buildup by providing constant recirculation through the heat exchanger on the DHW side. It also preheats the cold water before it enters the heat exchanger.

9. Heat exchanger

Allows water to flow between plates for maximum heat transfer while keeping boiler water from contacting potable water.

10. Frame / skid assembly

Supports the HEX and piping while providing another method to move and transport the unit.

Typical IPW Packaged Water Heater

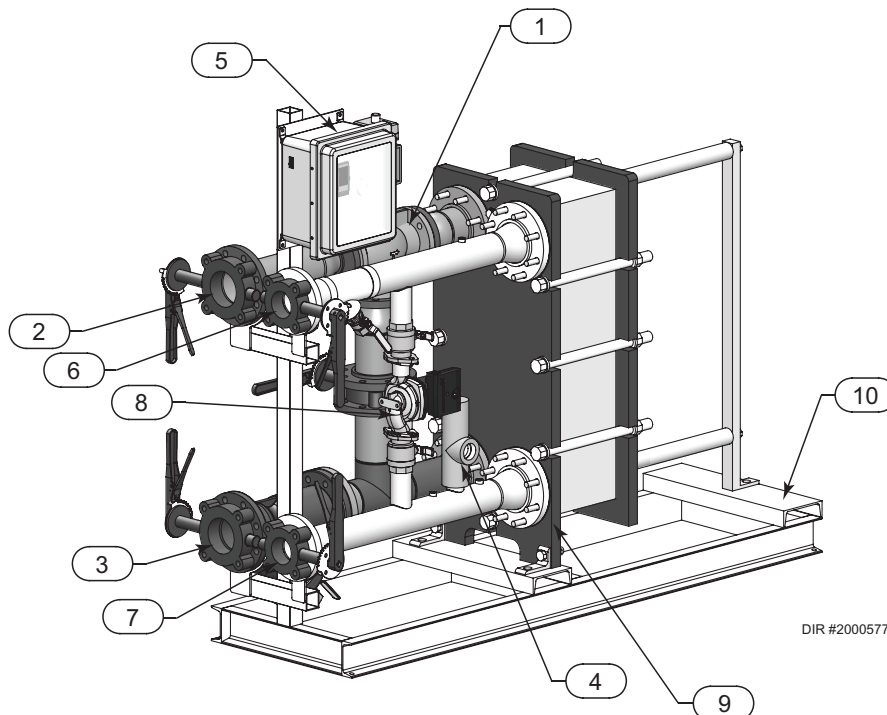

DIR #2000577418

1 Determine IPW location

Before locating the appliance, check:

1. Check for nearby connection to:
 - Heating system water piping
 - Electrical power
 - DHW system water piping
2. Locate the appliance so that if water connections should leak, water damage will not occur. When such locations cannot be avoided, it is recommended that a suitable drain pan, adequately drained, be installed under the appliance. Under no circumstances is the manufacturer to be held responsible for water damage in connection with this appliance, or any of its components.
3. If a new water heater will replace an existing water heater, check for and correct system problems, such as:
 - System leaks causing oxygen corrosion or heat exchanger cracks from hard water deposits.
 - Incorrectly-sized expansion tank.
 - Lack of freeze protection in the appliance water causing the system and the appliance to freeze and leak.



WARNING

This appliance is certified as an indoor appliance. Do not install the appliance outdoors or locate where the appliance will be exposed to freezing temperatures or to temperatures that exceed 100°F.

Do not install the appliance where the relative humidity may exceed 95%. Do not install the appliance where condensation may form on the inside or outside of the appliance, or where condensation may fall onto the appliance.

Site selection and preparation

Ensure that the site selected for installation of the IPW water heater includes the following:

- Access to AC input power at 120 VAC/60 Hz
- Close proximity to system boiler loop to be used as heating fluid source.
- If applicable, access to ModBus network wiring within the prescribed wire lengths (see the Section 6 - Wiring)

Installation clearances

The heater must be installed with the prescribed clearances for service as shown in FIG. 1-1 on page 6. The recommended minimum clearance dimensions are listed below; however, if local building codes require additional clearances, these codes shall supersede the recommendations listed below:

- Sides: 24 in. (61 cm)
- Front: 24 in. (61 cm)
- Rear: 24 in. (61 cm)
- Top: 12 in. (30.5 cm)

All water piping and electrical conduit must be arranged so that it does not interfere with the removal of the IPW water heater assemblies/parts or inhibit service or maintenance of the unit.

1 Determine water heater location

Figure 1-1 IPW Water Heater Clearances and Dimensions

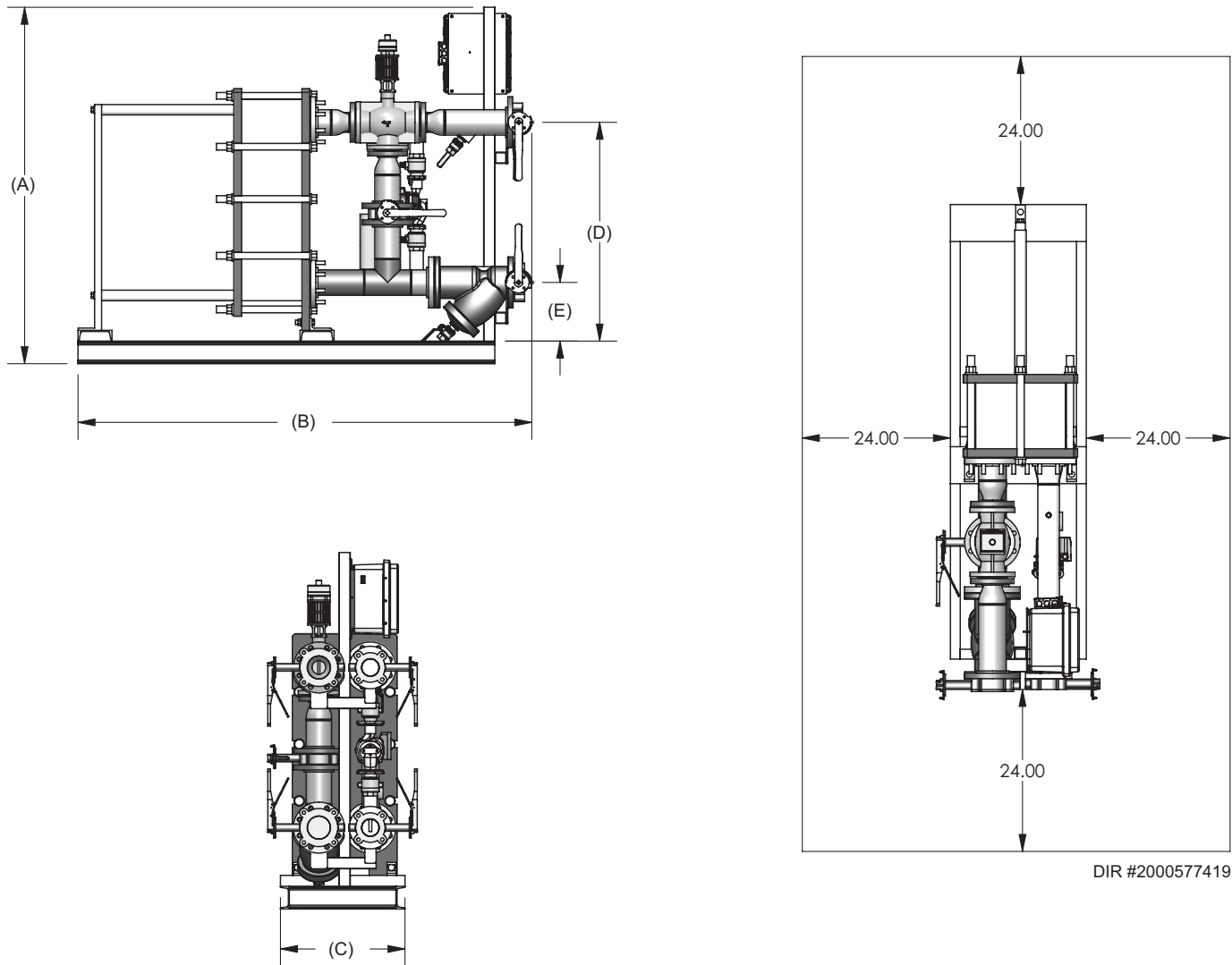

DIR #2000577419

MODEL	A	B	C	D	E
IPW015DW	56"	37 3/4"	15"	30 3/4"	5 1/2"
IPW030DW	56"	43 1/2"	15"	30 3/4"	5 1/2"
IPW050DW	56"	43 1/2"	15"	30 3/4"	5 1/2"
IPW070DW	63"	50 1/4"	22"	36 3/4"	8 1/2"
IPW090DW	63"	56 1/2"	22"	36 3/4"	8 1/2"
IPW105DW	63"	54 1/2"	22"	36 3/4"	8 1/2"
IPW120DW	63"	52 1/2"	22"	36 3/4"	8 1/2"

2 Prepare water heater

Receiving and unpacking the IPW

All of the IPW water heaters are shipped fully assembled and ready for installation; therefore, installation will consist of the following tasks:

- Unpack the IPW water heater from its shipping container
- Position and secure the IPW water heater at the site
- Connect the heating loop/system piping to the IPW
- Connect the Domestic Hot Water (DHW) piping to the IPW
- Connect external AC power to the IPW electronic control box
- If required, connect ModBus control wiring to the temperature controller in the electronic control box

Each IPW water heater is shipped as a single crated unit. The unit must be moved with the proper equipment (forklift, pallet jack, etc.) to avoid possible injury to personnel or damage to the shipping container or unit. The shipping carton should be inspected for damage incurred during transit prior to signing the bill of lading.

NOTICE

Lochinvar is not responsible for lost or damaged freight. The freight carrier must be notified immediately of any damage detected.

Unpack the IPW water heater from its shipping container taking care not to damage the unit when cutting away the packaging material. Remove the bolts securing the IPW to its shipping skid. Perform a complete visual inspection of the unit to ensure there is no evidence of damage.

CAUTION

While packaged in the shipping container, the heater must be moved using a forklift or pallet jack. After unpacking, the heater should be lifted and moved using the frame cutouts (double-wall model) provided on the heater.

Setting the unit

IPW water heaters contain two (2) round cutouts on the frame plate and two (2) on the pressure plate of the heat exchanger (FIG. 2-1). Use these tabs or cutouts to lift and move the unit as specified in the heat exchanger (HEX) manual supplied with the unit.

In multiple unit installations, it is important to plan the position of each unit in advance. Sufficient space for piping connections and future service/maintenance requirements must also be taken into consideration. All piping must include ample provisions for expansion.

Figure 2-1 Lifting Provisions

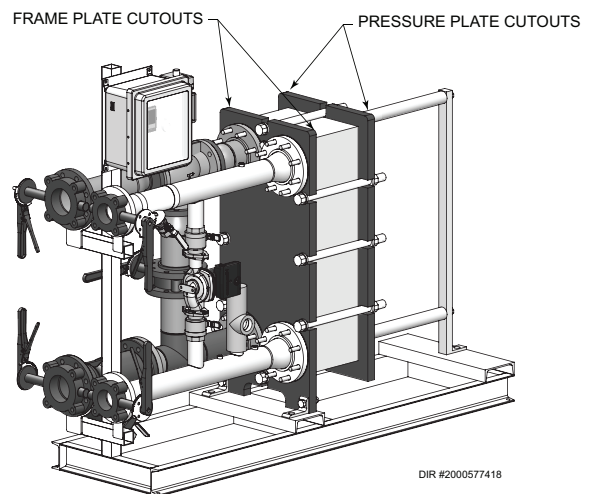

3 Hydronic piping

IPW piping assemblies

The diameter of the piping assemblies furnished with the water heater will depend on the size of the heat exchanger installed in the model ordered. Smaller sized models utilize 2" piping assemblies, while all other sizes utilize 3" and 4" piping assemblies used in each double-wall model. See Table 3A for sizing of piping assemblies used in each double-wall model.

Table 3A IPW Piping Assemblies

Model	Piping Assembly Diameter
IPW015 - IPW050	2"
IPW070 - IPW090	3"
IPW105 - IPW120	4"

General piping information

In addition to the heat exchanger and piping components, each IPW piping assembly contains a number of other important components and assemblies:

- Recirculation Pump (Continuously ON)
- Isolation
- Strainers (Boiler Water & DHW Sides)
- Blow-down Valves
- Pressure & Temperature (P & T) Relief Valve

Figure 3-1 illustrates the locations of the above mentioned components for a double-wall heat exchanger.

Figure 3-1A Typical IPW Piping

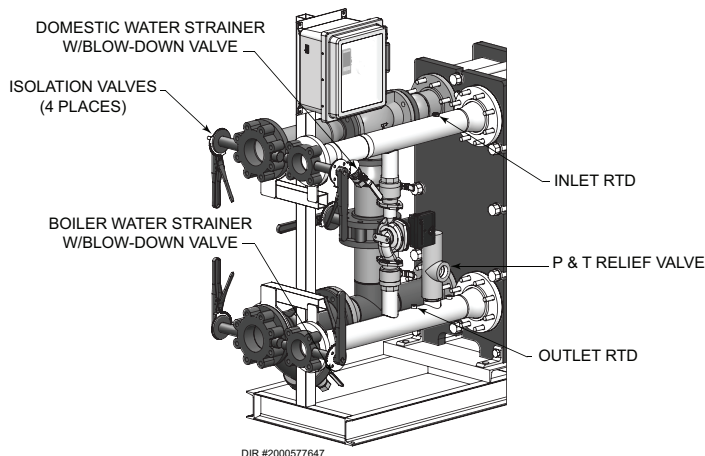

Heating fluid and Domestic Hot Water (DHW) piping

The diameter of the heating fluid (hot boiler water) and DHW piping will depend on the model number and size of the water heater being installed. Reference Table 3A (this page) for applicable piping sizes.

Scalding

This water heater can deliver scalding temperature water at any faucet in the system. Be careful whenever using hot water to avoid scalding injury. Certain appliances such as dishwashers and automatic clothes washers may require increased temperature water. By setting the thermostat on this water heater to obtain the increased temperature water required by these appliances, you may create the potential for scald injury. To protect against injury, you should install a mixing valve in the water system. This valve will reduce point of discharge temperature by mixing cold and hot water in branch supply lines. Such valves are available from the local plumbing supplier.

Figure 3-1B Scald Warning

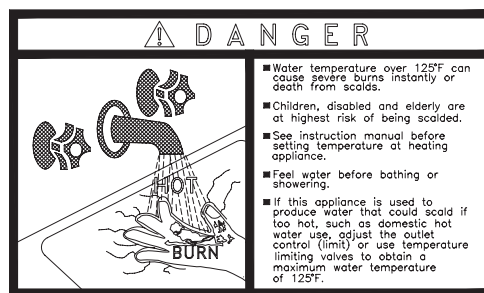

The following chart (Table 3B) details the relationship of water temperature and time with regard to scald injury and may be used as a guide in determining the safest water temperature for your applications.

Table 3B Approximate Time / Temperature Scald Chart

APPROXIMATE TIME / TEMPERATURE RELATIONSHIPS IN SCALDS	
120°F	More than 5 minutes
125°F	1 1/2 to 2 minutes
130°F	About 30 seconds
135°F	About 10 seconds
140°F	Less than 5 seconds
145°F	Less than 3 seconds
150°F	About 1 1/2 seconds
155°F	About 1 second

Anti-scald mixing valve:

Field supplied. An anti-scald mixing valve is recommended when domestic hot water supply is above 115°F.

NOTICE

The water inlet and outlet threaded connections are steel. When connecting the unit to piping made of a different material, use of a dielectric fitting or a dielectric union conforming to ASSE 1079 is recommended to prevent corrosion and potential subsequent water leaks at or near the connection. Dielectric fittings may be required by local plumbing codes.

3 Hydronic piping *(continued)*

Figure 3-2 Water to Water Heat Exchanger Single Unit

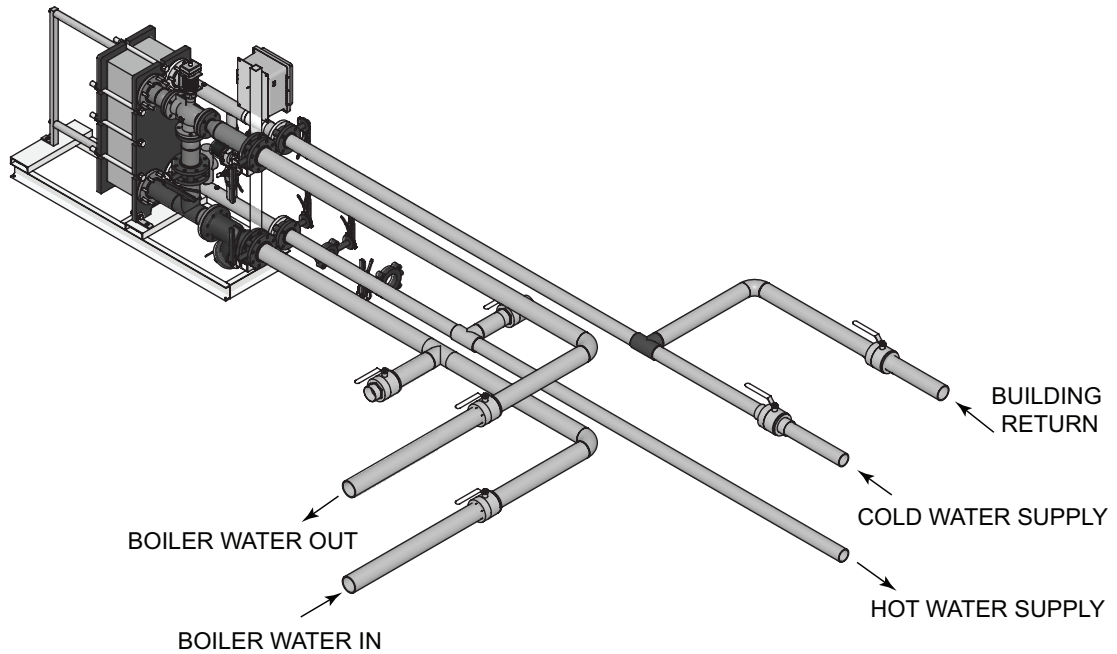

DIR #2000577498

CAUTION Mixing valves are required for the protection of low temperature loops.

NOTICE Please note that these illustrations are meant to show system piping concept only, the installer is responsible for all equipment and detailing required by local codes.

3 Hydronic piping

Figure 3-3 Water to Water Heat Exchanger Single Unit with Stratified Tank

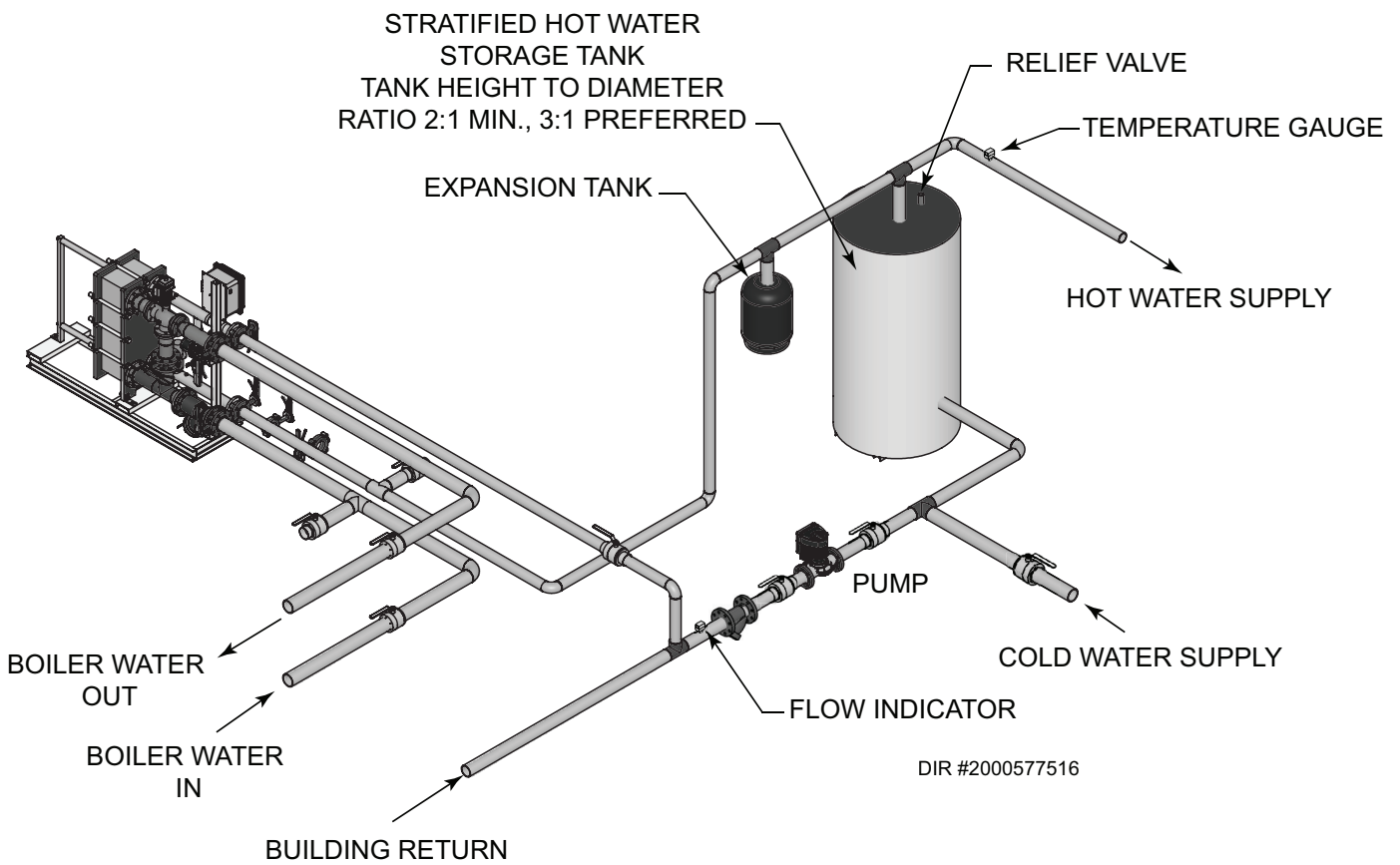

NOTICE

Please note that these illustrations are meant to show system piping concept only, the installer is responsible for all equipment and detailing required by local codes.

3 Hydronic piping *(continued)*

Figure 3-4 Water to Water Heat Exchanger Multiple Units

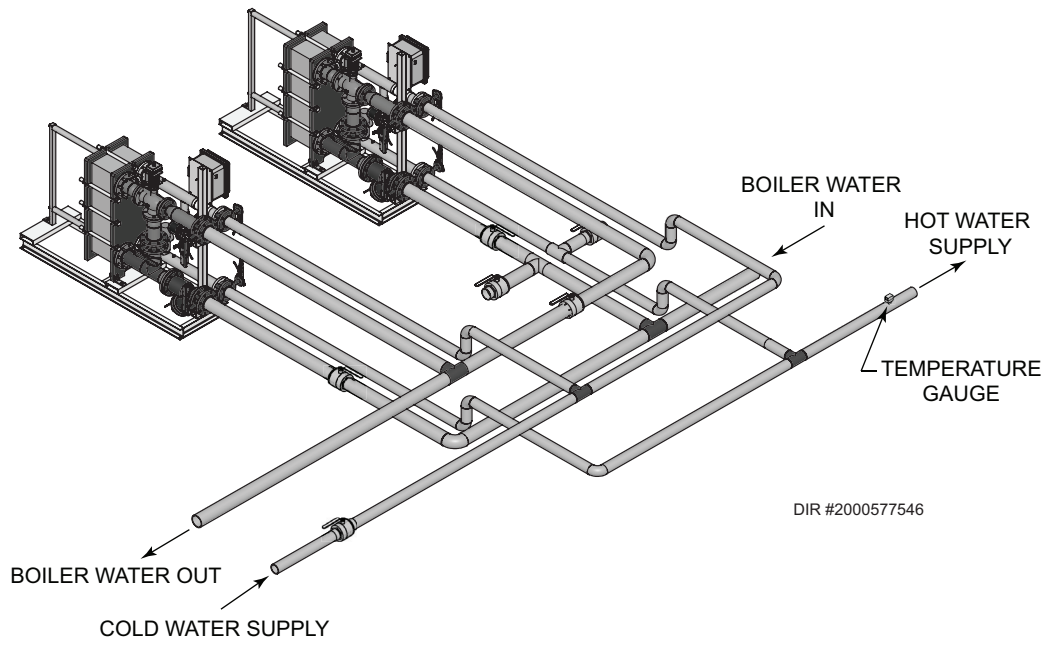

NOTICE Please note that these illustrations are meant to show system piping concept only, the installer is responsible for all equipment and detailing required by local codes.



3 Hydronic piping

Figure 3-5 Water to Water Heat Exchanger Single Unit with Accumulator Tank

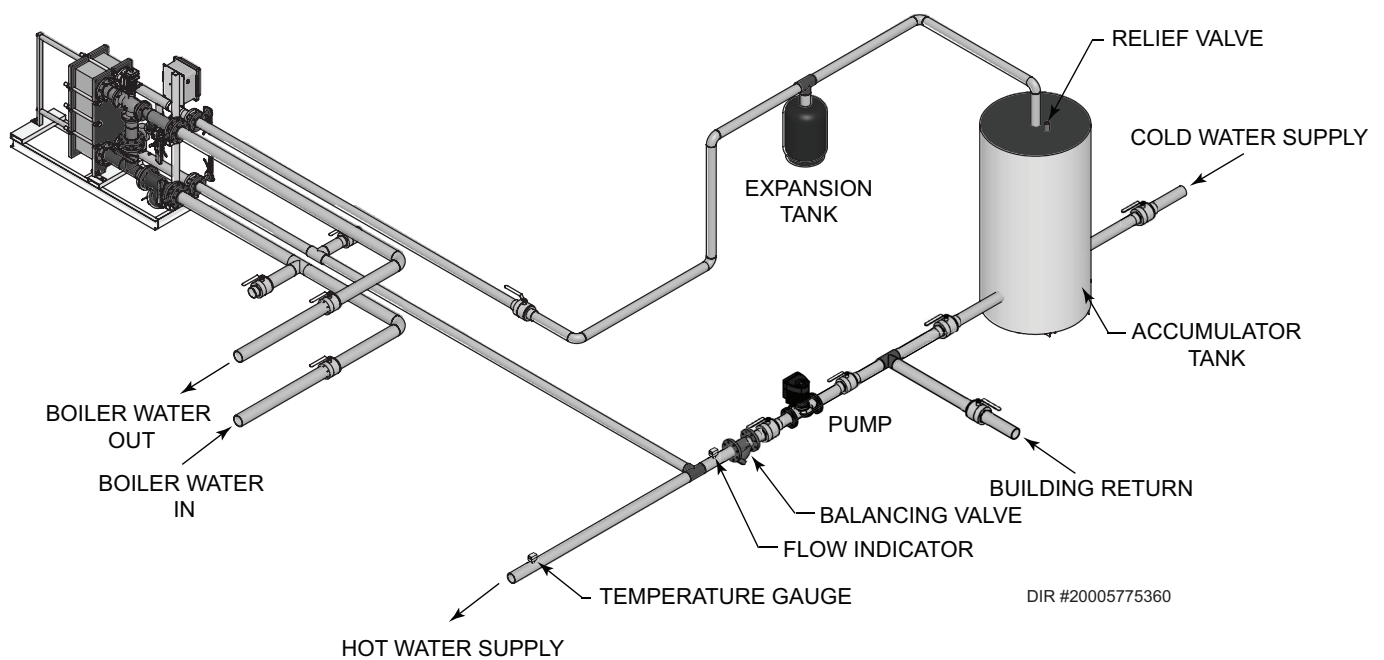

NOTICE Please note that these illustrations are meant to show system piping concept only, the installer is responsible for all equipment and detailing required by local codes.



3 Hydronic piping *(continued)*

Figure 3-6 Multiple Units with Boiler Side Buffer Tank as a Zone

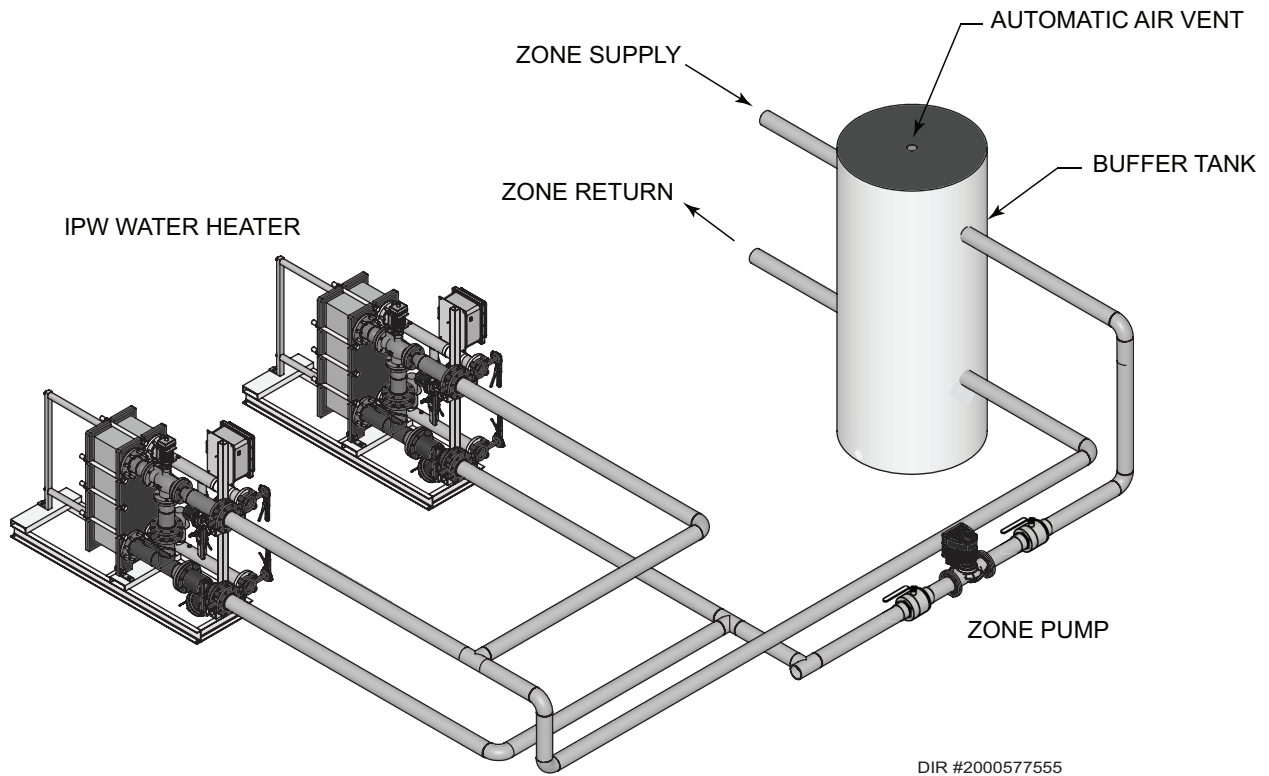

DIR #2000577555

NOTICE Please note that these illustrations are meant to show system piping concept only, the installer is responsible for all equipment and detailing required by local codes.



3 Hydronic piping

Figure 3-7 Multiple Units with Conventional Heating System as a Zone

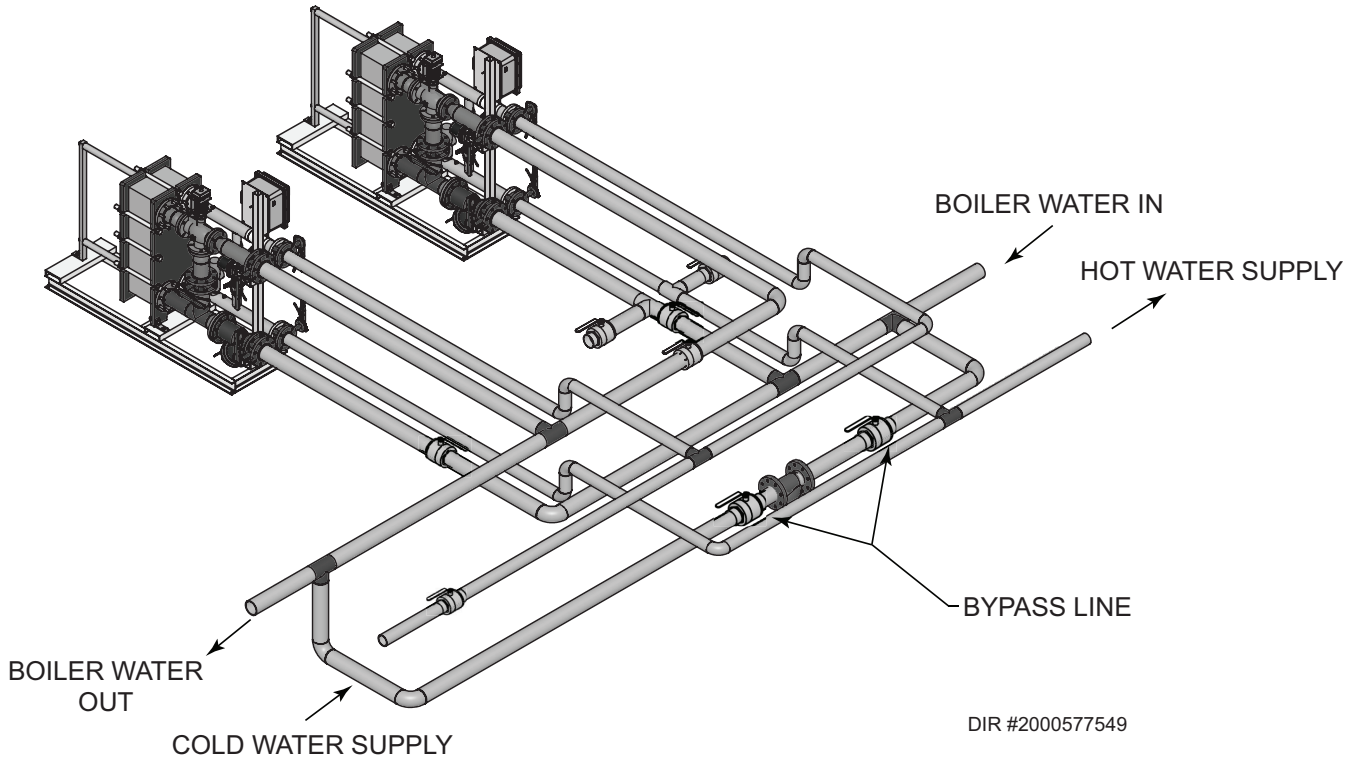

NOTICE Please note that these illustrations are meant to show system piping concept only, the installer is responsible for all equipment and detailing required by local codes.

4 Adjustments

This section provides the adjustment procedures for the 3-way control valve (FIG. 4-1) and the IPW electronic control system.

Prior to shipment from Lochinvar, control valve actuators are adjusted (auto-stroked) to ensure that they properly position the control valve from the fully-open to the fully-closed positions. In addition, the electronic control system is adjusted to the set point temperature specified on the sales order.

It is recommended that the following procedures be performed to the extent necessary, prior to placing the water heater into operation. Also, the applicable procedures MUST be performed following replacement of the control valve or electronic control system components to ensure that all parameters are properly set.

CAUTION As a precaution, ensure that all heating fluid (hot boiler water) shutoff valves are fully closed prior to performing any of the following adjustment procedures.

Figure 4-1 3-Way Control Valve

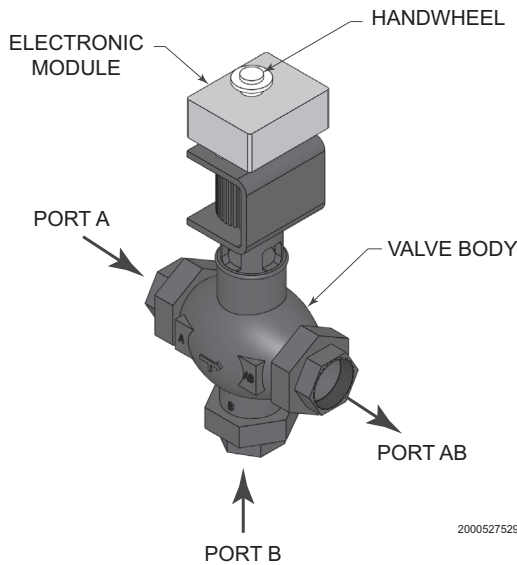

3-way control valve adjustment

The 3-way control valves used on all IPW models are powered by 24 VAC. For IPW applications, each 3-way valve is controlled by a 0 to 10 VDC signal received from the temperature controller contained in the electronic control system. A 0 VDC signal places the control valve in the full bypass position from port B to port AB (valve shaft up). A 10 VDC signal places the control valve in the full flow position from port A to port AB (valve shaft down).

Control valve calibration and status indications

The control valve actuators are self-calibrating for all valve sizes; therefore, simply proceed as follows to automatically adjust the valve actuator:

1. Reference FIG. 4-2 and loosen the two (2) captive screws securing the cover on the electronic module of the control valve. Remove hand-wheel ring.

Figure 4-2 Control Valve Electronics Module - Top View

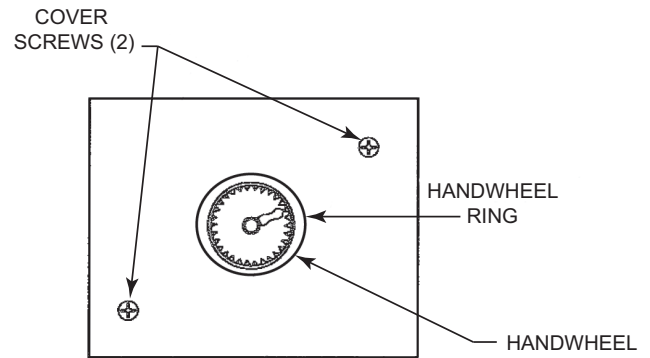

2. Remove the electronics module cover from the valve to access the internal components as shown in FIG. 4-3.

Figure 4-3 Control Valve with Electronics Module Cover Removed

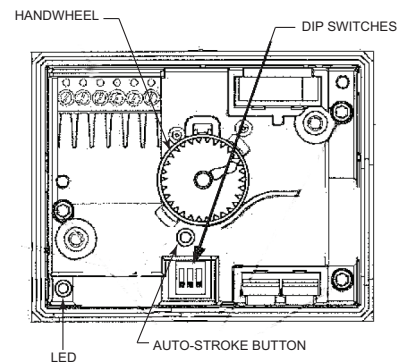

NOTICE When external 120 VAC power is properly connected to the control box, 24 VAC power is supplied to the control valve when the control box POWER switch is set to the ON position. The POWER switch is located on the front of the control box.

3. Ensure that all three (3) DIP switches shown in FIG. 4-3 are in the OFF (Down) position as shown.



4 Adjustments

4. Set the control box POWER switch to the ON position to apply 24 VAC power to the control valve actuator (pins 1 (G0) and 2 (G)). Ensure the valve is in the AUTO position, the LED indicator will light green continuously indicating that valve operation is normal (no faults).
5. Using a pin or paper clip, depress the AUTO-STROKE button in the opening of the terminal housing (FIG. 4-3). This will initiate calibration of the control valve.
6. During actuator calibration, the LED indicator (FIG. 4-3) will flash green for approximately 10 seconds. The control valve will be briefly closed and fully opened.
7. Upon successful completion of the valve calibration process, the LED indicator will stop flashing and remain ON continuously green.
8. The two-color (red/green) indicator is useful in determining the operating status of the control valve. Reference Table 4A for descriptions of the possible LED status displays which may be encountered.

Table 4A Control Valve LED Status Indicators

LED Display	Status	Description
LED green	On Continuously	Automatic Mode (normal, no faults)
	Flashing	- Mechanically set to MANUAL - Mechanically set to OFF - Currently in Auto-Calibrate Mode
LED red	On Continuously	- General fault - General calibration fault - Microprocessor fault
	Flashing	- Faulty 24 VAC supply (too low)
LED	Off	- No 24 VAC supply - Electronics module fault

9. Turn off power to the control valve by setting the control box POWER switch to the OFF position.
10. Replace and secure the electronics module cover by tightening the two (2) captive screws.

⚠ WARNING Manual control operation of the 3-way valve disables the over-temperature and power loss safety shutdown features of the system. Manual operation is only used for problem diagnosis. Manual operation may cause over-heating of domestic water and scalding of water users.

Manual control of 3-way valve - removable handwheel to hamper tampering

If desired, the control path (A-to-AB) of the control valve can be opened manually up to 95% of full-stroke. Reference FIG. 4-4 and proceed as follows:

1. Remove the water heater from service prior to using the Manual Operating Mode.
2. Press the handwheel inward and rotate it clockwise to the MANUAL position. This will disable the 0 to 10 VDC control signal from the temperature controller. The valve can now be mechanically rotated. The temperature control system is now disabled. Be sure to return to the Auto Mode prior to returning the system to heating service use (see Step 4).
3. To disable automatic control of the valve, press the handwheel inward and rotate it counterclockwise to the OFF position. This will close the valve.
4. To set the valve for automatic (AUTO) operation, rotate the handwheel to the AUTO position. The handwheel will pop up when in the AUTO position, thereby allowing it to be controlled by the temperature controller.

Figure 4-4 Control Valve Auto, Manual, and Off Positions

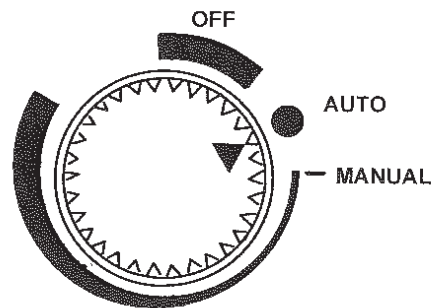

4 Adjustments *(continued)*

The control and the high limit are set at factory defaults. If changes are required, the set point and high limit can be easily changed. This is accomplished using the controls provided on the temperature controller and the high limit switch contained in the control box (see FIG. 4-5). The controller can be viewed on the front door of the control box. The High Limit is inside the panel.

Figure 4-5 Control Box - Front View

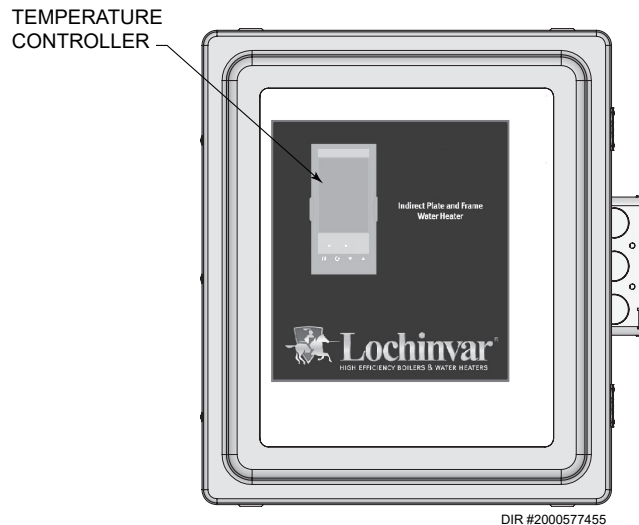

NOTICE

When the power switch on the control box is set to the ON position, it also energizes the internal 24 VAC transformer in the control box. This in turn provides 24 VAC power to the control valve actuator, provided the water temperature at the heater outlet is below the high temperature limit setting.

Set point temperature adjustment

The set point temperature is adjusted using the controls and displays provided on the temperature controller. These controls and displays are illustrated and described in FIG. 4-6 and Table 4B on page 18. If necessary, set point temperature adjustment is accomplished as follows:





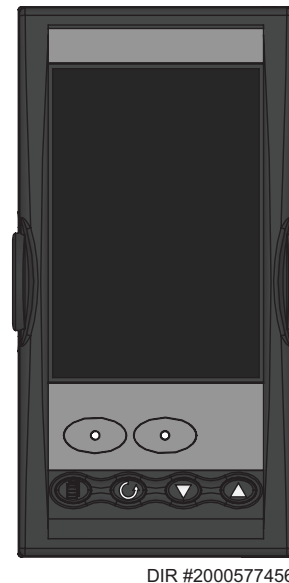

1. Set the ON/OFF POWER switch on the right side to the ON position. The temperature controller will initiate a self-test for approximately 3 seconds. Following the self-test, the top display will show the current outlet water temperature of the heater above the current set point temperature stored in memory.
2. Ensure that the temperature controller is set to AUTO (automatic) Mode and the AUTO indicator is lit. If the MAN indicator is lit, press the AUTO/MAN button to toggle the mode setting.
3. If the lower display does not show the desired set point temperature, press the ▲ or ▼ arrow button to change the display to the desired value.
4. Two seconds after the ▲ or ▼ arrow button is released, the display will blink to indicate that the temperature controller (FIG. 4-6) has accepted and stored the displayed value.

Figure 4-6 Temperature Controller



4 Adjustments

Table 4B Temperature Controller Operating Controls, Indicators and Displays

CONTROL or INDICATOR	MEANING	FUNCTION
SP	Set Point Indicator	SP for multiplier factory set at 0.
REM	Remote Set Point Active	Illuminates when remote set point is active.
	Auto/Manual Button and Indicator	Not used. If "MAN" is lit in the top of the screen, press AUTO/MAN to put the control back into Auto Mode.
	Run/Hold Button and Indicators	Not used for IPW applications.
(a) 	Page Button	Press PAGE button to select new page headings.
(b) 	Scroll Button	Press SCROLL button to select a new parameter on the page.
(c) 	Down Button	Press DOWN button to decrease an analogue value, or to change the state of a digital value.
(d) 	Up Button	Press UP button to increase an analogue value, or to change the state of a digital value.

5 Operating information

An electronic control system coupled with a control valve results in a highly responsive system which provides virtually constant hot water flow at the selected set point temperature.

Accessories included with the IPW water heater include:

- Boiler water and domestic water Y-strainers with blow-down valves
- Pressure & Temperature relief valve
- Isolation valves and domestic water drain valve
- Integral domestic water circulator pump

The following paragraphs provide a top-level functional overview of system operation.

Sequence of operation

The cold water enters the heat exchanger through the inlet connection and strainer. Cold water flows through the plate heat exchanger, where it is heated by hot boiler water, and then discharged through the Domestic Hot Water (DHW) outlet connection. A portion of hot water is mixed with the cold water entering the heater.

Boiler water supplied to the heat exchanger passes through the inlet connection and strainer. The boiler water heats the colder domestic water, and is then discharged through the boiler water outlet connection. The boiler water flow is controlled by a 3-way valve.

For IPW double-wall heat exchanger models, heat transfer plates are positioned together to form one assembly with an air space between them. This protects against leakage of boiler water into the domestic water. If one of the plates should develop a leak (boiler water or domestic water, whichever is leaking), the water will enter the air space and exit to the atmosphere. It will flow through leak detection channels alerting an operator that a leak has occurred.

Electronic control overview

The primary control mechanism for the electronic control system is an electronic process controller which is installed in the control box. The controller utilizes feed forward and PID (Proportional Integral Derivative) algorithms to provide precise control of the water heater outlet temperature. Outlet temperature control is accomplished by modulating the open/closed position of the control valve actuator.

The controller continuously monitors the water heater outlet temperature via an RTD located in the outlet port. The controller also receives a signal from the temperature sensor mounted in the mixed water inlet as shown in FIG. 3-1A. The mixed water sensor monitors flow changes through the water heater and provides a signal to the controller proportional to the change in flow. The mixed water temperature provides an instantaneous response for the specified flow range of the unit.

The controller provides a 0 - 10 VDC output signal to the control valve actuator. This 0 - 10 VDC signal proportionally modulates the control valve position from fully closed (0 VDC) to fully open (10 VDC). The control signal varies as necessary to maintain the set point temperature programmed into the controller. Under normal conditions, the IPW water heater outlet temperature is maintained within $\pm 4^\circ\text{F}$ of the desired set point based on a load change of 50% or less.

Over-temperature control and safety features

The control box contains an over-temperature switch which continuously monitors the outlet water temperature of the heater. Normally, the over-temperature switch is set to 20°F above the set point temperature for the water heater. If the programmed over-temperature limit is exceeded, the over-temperature switch is activated. This in turn disconnects power from the control valve actuator moving the control valve to the full bypass position (B- AB). It should be noted that the over-temperature switch has a slightly slower response to temperature changes than the temperature controller.

The control valve actuator also incorporates a "Fail Safe" feature which automatically closes the valve if there is a loss of the 0 - 10 VDC control signal or loss of input power. The 24 VAC power supply transformer has an integral 3 amp circuit breaker to protect the control valve electronics.

6 Wiring

Electrical wiring connections

The control box and all other electronic control system components are installed on the IPW water heater prior to shipment from the factory. Therefore, electrical connections to the electronic control system basically consist of connecting external AC power to the electronic control system control box. The system can be powered by a single-phase AC voltage of 120 VAC, 60 Hz. However, if the electronic control system was ordered with the ModBus Communication option, several additional signal lead connections will need to be made inside the control box. These signal leads will permit the electronic control system to be controlled by an external Energy Management System (EMS), Building Automation System (BAS), or computer. Proceed as follows:

1. Open the junction box on the side of the control box.
2. Route the power wiring harness into the junction box through one of the knockouts as shown in FIG. 6-1.
3. Connect 120V power supply to the wires in the junction box:
 - Black - Live
 - White - Neutral
 - Green - Ground

CAUTION

DO NOT route ModBus communication wiring in the same conduit as power wiring. Attempting to do so may result in excessive noise on the signal lines. Also, ensure that the RS232 or RS485 signal cable connections do not exceed the following lengths:

RS232 Cable: 50 feet maximum

RS485 Cable: 4,000 feet maximum

NOTICE

The complete wiring diagram for the IPW electronic control system is provided in Section 11 of this manual.

NOTICE

Lochinvar recommends that shielded, twisted-pair cable be used for communication wiring.

Figure 6-1 Junction Box

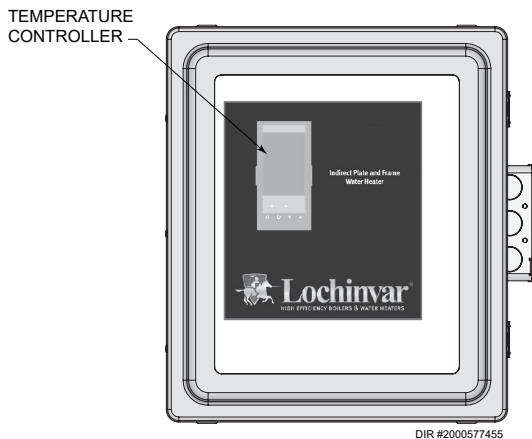

NOTICE

Use a minimum of 14 AWG wire for AC power wiring connections to the electronic control system control box.

4. If ModBus is not used, no further steps are required for the IPW. If no further connections are required, re-secure the junction box door (FIG. 6-1).

7 ModBus

Installation Procedure

1. Turn OFF the main electrical power to the appliance.
2. Open the control box door by loosening the screws clamping the door closed.
3. Connect wires to the control following the diagram in Figure 7-1.
4. Close the control box door.
5. Turn on the main electrical power.
7. Configure the control per this manual and resume operation.

Figure 7-1_Harness Connections

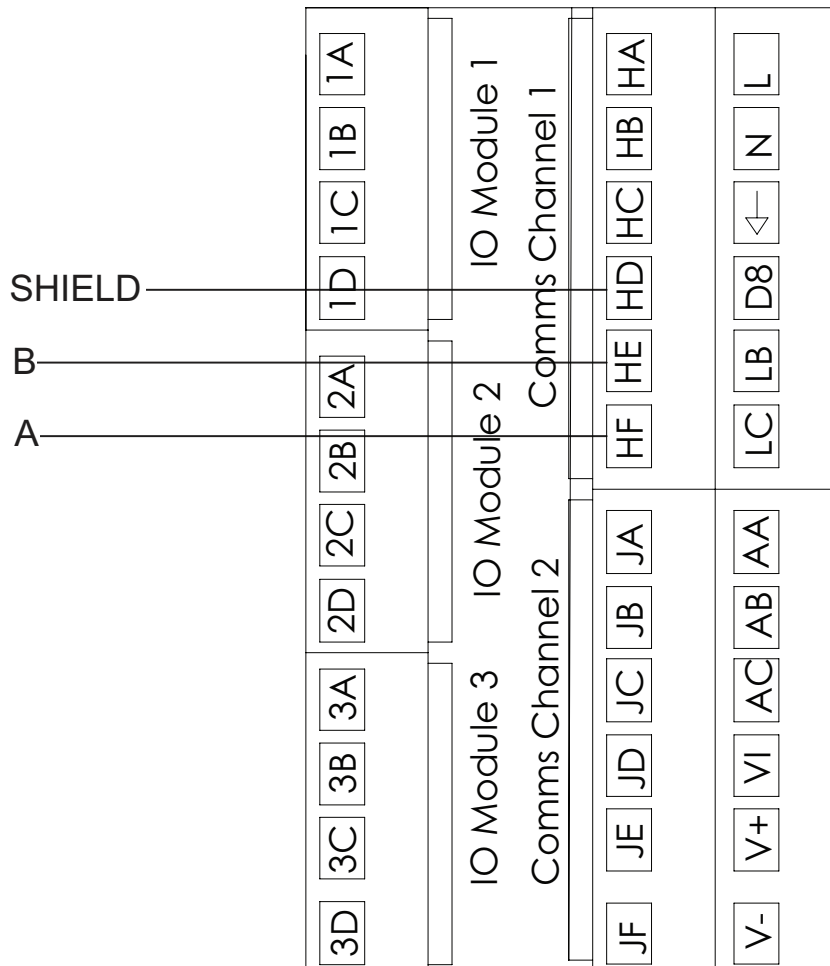

7 ModBus

ModBus Exception Codes

MODBUS Exception Codes		
Code	Name	Meaning
01	ILLEGAL FUNCTION	The function code received in the query is not an allowable action for the server (or slave). This may be because the function code is only applicable to newer devices, and was not implemented in the unit selected. It could also indicate that the server (or slave) is in the wrong state to process a request of this type, for example because it is unconfigured and is being asked to return register values.
02	ILLEGAL DATA ADDRESS	The data address received in the query is not an allowable address for the server (or slave). More specifically, the combination of reference number and transfer length is invalid. For a controller with 100 registers, the PDU addresses the first register as 0, and the last one as 99. If a request is submitted with a starting register address of 96 and a quantity of registers of 4, then this request will successfully operate (address-wise at least) on registers 96, 97, 98, 99. If a request is submitted with a starting register address of 96 and a quantity of registers of 5, then this request will fail with Exception Code 0x02 "Illegal Data Address" since it attempts to operate on registers 96, 97, 98, 99 and 100, and there is no register with address 100.
03	ILLEGAL DATA VALUE	A value contained in the query data field is not an allowable value for server (or slave). This indicates a fault in the structure of the remainder of a complex request, such as that the implied length is incorrect. It specifically does NOT mean that a data item submitted for storage in a register has a value outside the expectation of the application program, since the MODBUS protocol is unaware of the significance of any particular value of any particular register.
04	SLAVE DEVICE FAILURE	An unrecoverable error occurred while the server (or slave) was attempting to perform the requested action.
05	ACKNOWLEDGE	Specialized use in conjunction with programming commands. The server (or slave) has accepted the request and is processing it, but a long duration of time will be required to do so. This response is returned to prevent a timeout error from occurring in the client (or master). The client (or master) can next issue a Poll Program Complete message to determine if processing is completed.
06	SLAVE DEVICE BUSY	Specialized use in conjunction with programming commands. The server (or slave) is engaged in processing a long -- duration program command. The client (or master) should re-transmit the message later when the server (or slave) is free.
08	MEMORY PARITY ERROR	Specialized use in conjunction with function codes 20 and 21 and reference type 6, to indicate that the extended file area failed to pass a consistency check. The server (or slave) attempted to read record file, but detected a parity error in the memory. The client (or master) can retry the request, but service may be required on the server (or slave) device.
0A	GATEWAY PATH UNAVAILABLE	Specialized use in conjunction with gateways, indicates that the gateway was unable to allocate an internal communication path from the input port to the output port for processing as the request. Usually means that the gateway is misconfigured or overloaded.
0B	GATEWAY TARGET DEVICE FAILED TO RESPOND	Specialized use in conjunction with gateways, indicates that no response was obtained from the target device. Usually means that the device is not present on the network.

7 ModBus *(continued)*

Primary Data Tables

Table	Data Type	Read / Write
Input Registers	16-Bit Word	Read Only
Holding Registers	16 Bit Word	Read / Write

Memory Map

Input Registers						
Address	Description	Default	Unit	Min.	Max.	Resolution
30004	Outlet Temperature	----	Degrees Fahrenheit	-328	1562	0.1
30006	Inlet Temperature	----	Degrees Fahrenheit	-328	1562	0.1
30008	Outlet Voltage (Valve Position)	----	Volts	0	10	0.01
Holding Registers						
40002	Setpoint	118	Degrees Fahrenheit	90	180	0.01

Physical Wiring

RS-485 Communication Bus

- Maximum Length = 4000 feet
- Cable Specification = 24 AWG / A,B (twisted pair) and GND Shielded, with characteristic Impedance = 120 ohm
- Maximum Load = 32 units (32 nodes)

NOTE: Cable must be terminated with 120 ohm impedance matching resistor on each end.

Figure 7-2_Wiring Diagram

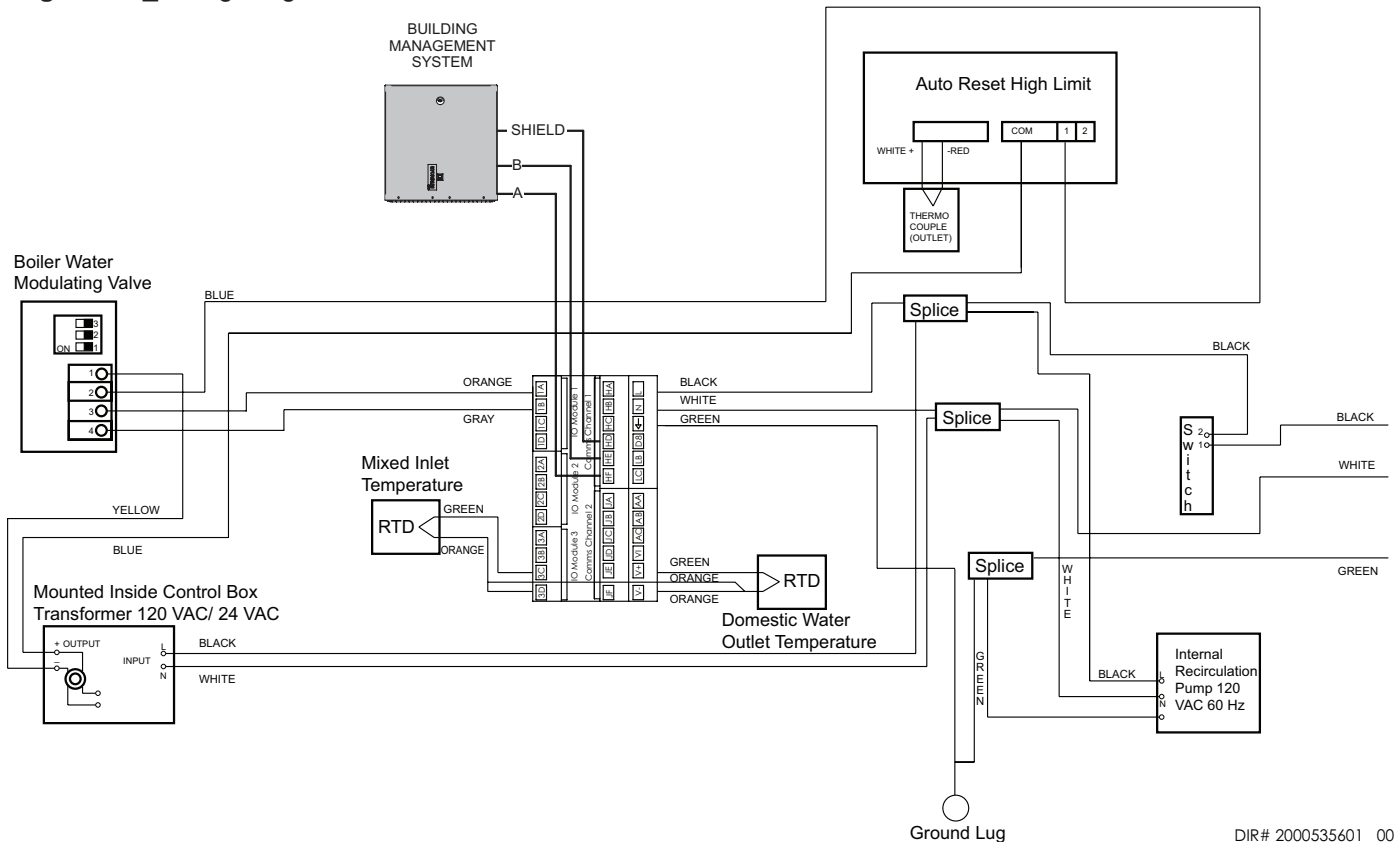

7 ModBus

Procedure to change ModBus address

1. Press and hold Page (F1) until "Access Go To [▲] [▼] Level 1" appears.
2. Press the [▲] button twice to get to Level 3.
3. Wait until "Pass Code [▲] [▼] 0" appears.
4. Press the [▲] button three (3) times to set the pass code to 3.
5. Wait until "[▲] [▼] Pass" appears.
6. Press Page (F1) until "Comms [▲] [▼] H" appears.
7. Press the [↻] button five (5) times to access "Address [▲] [▼] 1."
8. Use the [▲] [▼] buttons to adjust the address.
9. Press and hold the Page (F1) and Next (F2) buttons together until the main screen appears.
10. Press and hold Page (F1) until "Access Go To [▲] [▼] Level 3" appears.
11. Press the [▼] button twice to return to Level 1.
12. Press Page (F1).

Troubleshooting

Should you encounter problems communicating over ModBus, the following items should be checked in this order:

1. Physical Layer
2. Communications Configuration and Port Settings
3. ModBus Error Codes

Physical Layer

1. Check that all components have power (IPW, Gateway, BAS Master)
2. Check all wire lengths. Are any drops too long?
3. Check proper shield grounding
4. Check A, B terminal connections
5. Check for Terminating Resistors (120 ohms)
6. Check for broken wires

Communications

1. Check Baud Rate (19200)
2. Check Parity (NO)
3. Check Slave ID
4. Check Port Setting on Master, Gateway, and Computers

ModBus Error Codes

1. Check ModBus communication for error codes (see page 22 for ModBus Exception Codes)
2. Check ModBus RTU
3. Check Slave ID
4. Check ModBus Command

8 Start-up

Introduction

This section provides the pre-optional checks, initial start-up and operating procedures for the IPW water heater.

⚠ WARNING Fluids **MUST BE** gradually introduced to the unit. Failure to do so can cause damage to heat exchanger plates. When the unit is empty or cold, **DO NOT** admit hot fluid to the unit suddenly. When unit is hot, **DO NOT** shock with cold fluid.

⚠ CAUTION **DO NOT** operate equipment exceeding design conditions as specified on the nameplate.

The IPW must never be subjected to pressure greater than the maximum differential pressure specified on the nameplate.

Sudden rises in pressure may cause leakage or damage to plates or gaskets of double-wall models.

Pre-operational checks and procedures

All IPW installation procedures provided in Section 2 - Prepare Water Heater must be fully completed prior to performing Pre-Operational checks. In addition, the following items should be checked:

1. Ensure that external single-phase AC power at 120 VAC/60 Hz is properly connected to the electronic control system control box.
2. Open the isolation valve in the cold water inlet line to the IPW water heater.
3. Verify that the electronic control system temperature controller set point and over-temperature switch alarm limit have been properly set using the procedures in Section 4 - Adjustments.
4. The air vent, located in the top of the manifold, allows air to escape during the fill process (a hissing sound may be heard). If a hissing sound is not heard through the air vent, close the air vent cap and then open it two (2) full turns counterclockwise. **DO NOT** remove the air vent cap.
5. When hissing sound from the air vent stops, carefully open the pressure and temperature (P & T) relief valve to vent any remaining air.
6. Close the P & T relief valve when the heater is full.

Initial start-up



In order to prevent a possible over-temperature condition during initial start-up, Lochinvar recommends that the following steps be performed in the order specified:

1. Set the POWER switch on the front of the box to the ON position. This will provide power to the complete electronic control system and control valve. When power is initially applied, the electronic control system temperature controller automatically performs a self-test sequence for approximately three (3) seconds. Proceed immediately to the next step.
2. Upon completion of the self-test, the temperature controller will show the present water heater outlet temperature in the upper display and the set point temperature is displayed right below that.
3. Open the stop valve in the building recirculation system, if employed.
4. Open the isolation valve in the hot water outlet line. Connect a hose to the field-piped hose connection (see piping diagrams in Section 3- Hydronic Piping or open several hot water fixtures in the building to ensure water flow through the heater.
5. Slowly open the isolation valves in the water inlet and water outlet connections of the heater.
6. When in the AUTO Mode, the electronic control system will stabilize at the selected set point temperature. Once stabilized, the electronic control system is set for unattended operation with no further operator intervention. The control may take several minutes to stabilize. Temperature may vary during this time. Stabilized when bottom PV is near bottom SP (0).
7. Close the hose connection or hot water fixtures opened in Step 4.
8. During start-up of double-wall models, there may be some evidence of leakage prior to the plates and gaskets reaching their working temperature. If leakage continues, contact the factory for assistance.

8 Start-up

Checking mixed inlet temperature

If desired, the water heater mixed inlet temperature can be monitored using the controls and displays on the temperature controller. This is accomplished as follows:

1. Press the PAGE button () until MATH 2 is displayed.
2. Press the UP button () until the right side value is 5.
3. Press the SCROLL button () until INPUT 2 is shown, this is the mixed inlet.
4. When INPUT 2 is shown in the upper display, the lower display will show the water heater mixed inlet temperature. The temperature will be displayed for several seconds and then the controller will revert to the default displays (outlet water temperature and set point).

Shutting down the system

To shut down the IPW for a short period of time, simply turn OFF power and close the isolation valves as described in Steps 1 and 2 below. However, if the IPW will shut down for an extended period of time, it will be necessary to drain the unit using the appropriate steps listed below for the type of heat exchanger used (double-wall). Proceed as follows:

1. Turn OFF the POWER switch on the side of the electronic control system control box.
2. Close all four (4) of the isolation ball valves.
3. Connect a drain hose to the strainer on the boiler water side of the piping assembly. Open the valve on the strainer and drain the water from the heater.
4. Next, connect a hose to the drain valve on the DHW side of the piping assembly.
5. Open the drain valve to drain the domestic water from the heater.
6. It is also advisable to separate and clean the plates. Reference the CD provided with the IPW for detailed instructions on cleaning the plates.
7. To place the IPW back in service, fill the unit and perform the pre-operational checks and start-up procedures described on page 25.

9 Maintenance

Maintenance and annual startup

The IPW water heater requires regular routine maintenance to keep the unit operating at optimum efficiency. Lochinvar recommends that the tasks listed in Table 9A - Scheduled Maintenance Actions, be performed at the periodic intervals specified.

Table 9A Scheduled Maintenance Actions

Interval	Maintenance
Weekly	Double-Wall Only: Check plate packs for leakage.
Quarterly	Every 3 months, check the operation of the over-temp switch in the electronic control system control box.
Quarterly / Semi-Annually	After the first 3 months, check the operation of the control valve in the boiler water piping. Then check operation every 6 months.
Semi-Annually	Every 6 months, check the strainers on both the boiler water and domestic water piping side.
Annually	Once each year, check the temperature sensors.
	Once each year, check the operation of the recirculation pump.
Periodic	Periodic cleaning of the heat exchanger may be necessary, depending on conditions and settings.

NOTICE

For specific maintenance instructions reference the CD provided with the IPW.

9 Maintenance

Periodic cleaning of heat exchanger

For a detailed description of the following maintenance tasks, reference the CD provided with the unit:

- De-scaling the heat exchanger
- Heat exchanger replacement

Strainers - inspection and replacement

The strainers are installed upstream of the energy source shutoff valve for the main traps. These strainers must be blown down periodically (approximately every three (3) to six (6) months) to prevent the build up of any sediment.

WARNING The combination of electricity and water can pose a very dangerous situation. Turn off / disconnect all electric power before attempting any maintenance procedure.

1. Follow Steps 1 through 5 of the shutdown procedure (page 26) to take the unit off-line before attempting to replace the energy source strainers.
2. The location of the strainers can differ between packages.
3. Carefully break the line connections on the inlet side of both strainers.
4. Carefully break the line connection on the outlet side of the strainers.
5. Remove and examine the strainers.

Oiled bearing circulators

1. The circulator shipped with the IPW water heater is water-lubricated. No oiling is required.
2. Check other circulators in the system. Oil any circulators requiring oil, following circulator manufacturer's instructions. Over-oiling will damage the circulator.

Figure 9-1 Domestic Water Side - Partial View

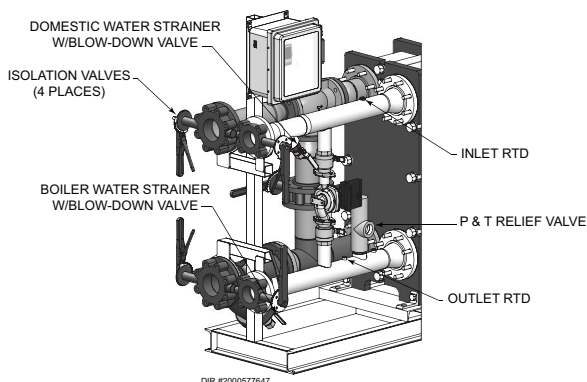

DIR #2000577647

Check water heater relief valve

1. Inspect the relief valve and lift the lever to verify flow. Before operating any relief valve, ensure that it is piped with its discharge in a safe area to avoid severe scald potential. Read Section 3 - Hydronic Piping before proceeding further.

WARNING Safety relief valves should be re-inspected AT LEAST ONCE EVERY THREE YEARS, by a licensed plumbing contractor or authorized inspection agency, to ensure that the product has not been affected by corrosive water conditions and to ensure that the valve and discharge line have not been altered or tampered with illegally. Certain naturally occurring conditions may corrode the valve or its components over time, rendering the valve inoperative. Such conditions are not detectable unless the valve and its components are physically removed and inspected. This inspection must only be conducted by a plumbing contractor or authorized inspection agency, not by the owner. Failure to re-inspect the water heater relief valve as directed could result in unsafe pressure buildup, which can result in severe personal injury, death, or substantial property damage.

WARNING Following installation, the valve lever must be operated AT LEAST ONCE A YEAR to ensure that waterways are clear. Certain naturally occurring mineral deposits may adhere to the valve, rendering it inoperative. When manually operating the lever, water will discharge and precautions must be taken to avoid contact with hot water and to avoid water damage. Before operating lever, check to see that a discharge line is connected to this valve directing the flow of hot water from the valve to a proper place of disposal. Otherwise severe personal injury may result. If no water flows, valve is inoperative. Shut down the water heater until a new relief valve has been installed.

2. After following the above warning directions, if the relief valve weeps or will not seat properly, replace the relief valve. Ensure that the reason for relief valve weeping is the valve and not over-pressurization of the system due to expansion tank waterlogging or undersizing.

10 Troubleshooting

Table 10A Troubleshooting Chart - No Display

FAULT	CAUSE	CORRECTIVE ACTION
No Display	No 120 VAC supplied to the unit	<ul style="list-style-type: none"> - Check external line switch, fuse, or breaker. - Ensure On/Off switch is in the ON position. - Check 120 VAC through the On/Off switch. - Check wiring harness connection between external power and control module.
	No voltage through the switch	<ul style="list-style-type: none"> - Replace switch.
	Bad control module	<ul style="list-style-type: none"> - Replace control module.
Low Outlet Water Temp	Modulating valve lost calibration	<ul style="list-style-type: none"> - Remove cover on modulating valve electronics and press the recessed calibration button to re-calibrate the valve.
	Boiler water supply temperature or flow has dropped below requirement to satisfy demand	<ul style="list-style-type: none"> - Ensure ball valves are open fully. - Ensure boiler water flow matches what is specified in the sizing table. - Ensure boiler side Y strainers are not clogged.
	Control module not supplying 0 - 10 VDC control signal to valve	<ul style="list-style-type: none"> - Ensure the valve is wired correctly by referencing the wiring diagram on page 32 of this manual.
	Modulating valve is not in AUTO Mode	<ul style="list-style-type: none"> - Rotate valve handle until it is in AUTO Mode.
	No 24 VAC power supplied to modulating valve	<ul style="list-style-type: none"> - Ensure the valve is wired correctly by referencing the wiring diagram on page 32 of this manual. - Ensure the transformer is connected to the harness correctly and its built-in circuit breaker has not tripped.
	Heat exchanger is improperly sized for load	<ul style="list-style-type: none"> - Reduce load on heat exchanger or re-size heat exchanger.
	Heat exchanger scaled on boiler side	<ul style="list-style-type: none"> - Clean and de-scale heat exchanger.
High Outlet Water Temp	High limit is tripped	<ul style="list-style-type: none"> - Ensure high limit is set correctly so that power to the valve will be restored when the temperature returns to a low enough value.
	Modulating valve is not in AUTO Mode	<ul style="list-style-type: none"> - Rotate valve handle until it is in AUTO Mode.
	Modulating valve lost calibration	<ul style="list-style-type: none"> - Remove cover on modulating valve electronics and press the recessed calibration button to re-calibrate the valve.
Temperature Swings Outside Specified Range	Heat exchanger scaled on DHW side	<ul style="list-style-type: none"> - Clean and de-scale heat exchanger.
	Pump not functioning	<ul style="list-style-type: none"> - Ensure pump is wired correctly by referring to the wiring diagram on page 32 of this manual. - Replace pump if faulty.
"S.Br" Displayed	RTD or RTD harness not connected or malfunctioning	<ul style="list-style-type: none"> - Ensure harness is connected and wired correctly by referring to the wiring diagram on page 32 of this manual. - Check RTD resistance by using the chart on page 30 to ensure RTD is functional. - Replace RTD or harness if faulty.
	RTD or RTD harness not connected or malfunctioning	<ul style="list-style-type: none"> - Ensure harness is connected and wired correctly by referring to the wiring diagram on page 32 of this manual. - Check RTD resistance by using the chart on page 30 to ensure RTD is functional. - Replace RTD or harness if faulty.

10 Troubleshooting

Checking temperature sensors

The temperature sensors (inlet and outlet water) are resistance type devices. The following tables show the correct values for the sensors at various temperatures. Use an ohmmeter to read the resistance of the sensor at a known temperature. If the resistance of the sensor does not closely match its corresponding table, replace the sensor.

Table 10B - Resistance vs. Temperature

Temperature (°F)	Resistance (Ohms)
-328	18.52
-310	22.83
-292	27.10
-274	31.34
-256	35.54
-238	39.72
-220	43.88
-202	48.00
-184	52.11
-166	56.19
-148	60.26
-130	64.30
-112	68.33
-94	72.33
-76	76.33
-58	80.31
-40	84.27
-22	88.22
-4	92.16
14	96.09
32	100.00

Temperature (°F)	Resistance (Ohms)
50	103.90
68	107.79
86	111.67
104	115.54
122	119.40
140	123.24
158	127.08
176	130.90
194	134.71
212	138.51
230	142.29
248	146.07
266	149.83
284	153.58
302	157.33
320	161.05
338	164.77
356	168.48
374	172.17
392	175.86

11 Sizing data

How to Properly Size Your Indirect Plate Water Heater

Table 11A Sizing Chart _ 60 - 120

DOMESTIC WATER INLET- OUTLET (°F)	BOILER WATER INLET TEMP (°F)	IPW MODEL	DOMESTIC		BOILER			KBTU/H REQUIRED
			FLOW (GPM)	PRESSURE LOSS (PSI)	MAX FLOW (GPM)	OUTLET TEMP (°F)	MAX. PRESSURE LOSS (PSI)	
60-120	125	IPW015DW	9	1	60	116	15	270
		IPW030DW	65	1	75	112	10	465
		IPW050DW	22	1	75	107	6	660
		IPW070DW	33	1	130	109	10	989
		IPW090DW	43	1	160	108	9	1,289
		IPW105DW	53	1	225	110	12	1,588
	IPW120DW	63	1	225	108	10	1,888	
	130	IPW015DW	12	1	60	117	15	359
		IPW030DW	21	1	75	113	10	629
		IPW050DW	29.5	1	75	106	6	869
		IPW070DW	46	1	130	108	10	1,379
		IPW090DW	58	1	160	108	9	1,738
		IPW105DW	72	2	225	110	12	2,158
	IPW120DW	85	2	225	107	10	2,547	
	140	IPW015DW	18	2	60	121	15	539
		IPW030DW	31	2	75	117	10	929
		IPW050DW	42	1	75	105	6	1,259
		IPW070DW	64	2	130	109	10	1,918
		IPW090DW	82	2	160	108	9	2,457
		IPW105DW	104	3	225	117	12	3,117
	IPW120DW	119	3	225	107	10	3,566	
	150	IPW015DW	22	3	60	127	15	659
		IPW030DW	39.5	3	75	117	10	1,184
		IPW050DW	53	2	75	106	6	1,588
		IPW070DW	80	3	130	112	10	2,397
		IPW090DW	104	4	160	110	9	3,117
		IPW105DW	132	4	225	114	12	3,956
	IPW120DW	151	3	225	108	10	4,525	
	160	IPW015DW	29	4	60	130	15	869
		IPW030DW	48	3	75	120	10	1,438
		IPW050DW	61	2	75	110	6	1,828
		IPW070DW	80	3	130	122	10	2,397
		IPW090DW	126	5	160	111	9	3,776
		IPW105DW	158	5	225	116	12	4,735
	IPW120DW	160	3	225	116	10	4,795	
	170	IPW015DW	33	5	60	136	15	988
		IPW030DW	56	4	75	124	10	1,678
		IPW050DW	74	3	75	109	6	2,218
		IPW070DW	80	3	130	132	10	2,397
		IPW090DW	145	6	160	114	9	4,345
		IPW105DW	160	5	225	126	12	4,795
	IPW120DW	160	3	225	126	10	4,795	
	180	IPW015DW	39	7	60	139	15	1,205
		IPW030DW	64	6	75	127	10	1,918
		IPW050DW	80	4	75	114	6	2,397
		IPW070DW	80	3	130	142	10	2,472
		IPW090DW	160	7	160	118	9	4,795
		IPW105DW	160	5	225	136	12	4,795
	IPW120DW	160	3	225	136	10	4,795	
	190	IPW015DW	43	9	60	144	15	1,319
		IPW030DW	73	7	75	129	10	2,188
		IPW050DW	80	4	75	124	6	2,397
		IPW070DW	80	3	130	152	10	2,472
		IPW090DW	160	7	160	128	9	4,795
		IPW105DW	160	5	225	146	12	4,795
	IPW120DW	160	3	225	146	10	4,795	
	200	IPW015DW	48	9	60	150	15	1,438
		IPW030DW	80	9	75	133	10	2,397
		IPW050DW	80	4	75	134	6	2,397
		IPW070DW	80	3	130	162	10	2,472
		IPW090DW	160	7	160	138	9	4,795
		IPW105DW	160	5	225	156	12	4,795
	IPW120DW	160	3	225	156	10	4,795	
	210	IPW015DW	51	11	60	157	15	1,528
		IPW030DW	80	9	75	143	10	2,397
		IPW050DW	80	4	75	143	6	2,397
		IPW070DW	80	3	130	172	10	2,472
		IPW090DW	160	7	160	148	9	4,795
		IPW105DW	160	5	225	166	12	4,795
	IPW120DW	160	3	225	166	10	4,795	
	220	IPW015DW	54	13	60	164	15	1,618
		IPW030DW	80	9	75	153	10	2,397
		IPW050DW	80	4	75	153	6	2,397
		IPW070DW	80	3	130	182	10	2,472
		IPW090DW	160	7	160	158	9	4,795
		IPW105DW	160	5	225	176	12	4,795
	IPW120DW	160	3	225	176	10	4,795	

NOTE: Highlighted items are limited by the maximum flow velocity through the piping.



11 Sizing data

Table 11B Sizing Chart _ 60 - 140

DOMESTIC WATER INLET- OUTLET (°F)	BOILER WATER INLET TEMP (°F)	IPW MODEL	DOMESTIC		BOILER			kBTU/H REQUIRED
			FLOW (GPM)	PRESSURE LOSS (PSI)	MAX. FLOW (GPM)	OUTLET TEMP (°F)	MAX. PRESSURE LOSS (PSI)	
60-140	145	IPW015DW	6.5	1	60	136	15	260
		IPW030DW	14.5	1	75	129	10	579
		IPW050DW	20.5	1	75	122	6	818
		IPW070DW	31	1	130	125	10	1,238
		IPW090DW	40	1	160	124	9	1,597
		IPW105DW	49	1	225	127	12	1,957
	150	IPW120DW	58.5	1	225	123	10	2,336
		IPW015DW	10	1	60	136	15	400
		IPW030DW	19	1	75	129	10	758
		IPW050DW	27	1	75	120	6	1,078
		IPW070DW	41	1	130	124	10	1,637
		IPW090DW	52	1	160	123	9	2,077
	160	IPW105DW	65	1	225	126	12	2,596
		IPW120DW	76.5	1	225	122	10	3,055
		IPW015DW	14	1	60	140	15	559
		IPW030DW	27	2	75	130	10	1,078
		IPW050DW	37	1	75	119	6	1,478
		IPW070DW	57	2	130	124	10	2,276
	170	IPW090DW	72	2	160	132	9	2,875
		IPW105DW	90	2	225	127	12	3,594
		IPW120DW	105.5	2	225	121	10	4,213
		IPW015DW	18	2	60	145	15	718
		IPW030DW	34	3	75	132	10	1,358
		IPW050DW	46	2	75	119	6	1,837
	180	IPW070DW	71	3	130	125	10	2,836
		IPW090DW	90	2	160	123	9	3,594
		IPW105DW	120	3	225	128	12	4,513
		IPW120DW	131	2	225	122	10	5,232
		IPW015DW	24	3	60	147	15	958
		IPW030DW	41	3	75	134	10	1,637
	190	IPW050DW	54.5	2	75	120	6	2,177
		IPW070DW	80	3	130	123	10	3,195
		IPW090DW	106	3	160	125	9	4,233
		IPW105DW	135	4	225	130	12	5,391
		IPW120DW	155	3	225	123	10	6,190
		IPW015DW	27	3	60	152	15	1,078
	200	IPW030DW	47	3	75	138	10	1,877
		IPW050DW	62.5	2	75	121	6	2,496
		IPW070DW	80	3	130	139	10	3,195
		IPW090DW	122	4	160	127	9	4,872
		IPW105DW	155	5	225	133	12	6,190
		IPW120DW	160	3	225	131	10	6,390
	210	IPW015DW	32	4	60	157	15	1,238
		IPW030DW	54	4	75	140	10	2,157
		IPW050DW	70.5	3	75	122	6	2,816
		IPW070DW	80	3	130	149	10	3,195
		IPW090DW	138	5	160	128	9	5,511
		IPW105DW	160	6	225	141	12	6,390
	220	IPW120DW	160	3	225	141	10	6,390
		IPW015DW	36	5	60	161	15	1,398
		IPW030DW	60	5	75	143	10	2,396
		IPW050DW	78	3	75	123	6	3,115
		IPW070DW	80	3	130	159	10	3,195
		IPW090DW	154	6	160	129	9	6,150
220	IPW105DW	160	6	225	150	12	6,390	
	IPW120DW	160	3	225	151	10	6,390	
	IPW015DW	39	6	60	165	15	1,558	
	IPW030DW	66	6	75	146	10	2,636	
	IPW050DW	80	3	75	131	6	3,195	
	IPW070DW	80	3	130	169	10	3,195	
220	IPW090DW	160	7	160	136	9	6,390	
	IPW105DW	160	6	225	160	12	6,390	
	IPW120DW	160	3	225	161	10	6,390	

NOTE: Highlighted items are limited by the maximum flow velocity through the piping.



11 Sizing data *(continued)*

Table 11C Sizing Chart _ 60 - 160

DOMESTIC WATER INLET- OUTLET (°F)	BOILER WATER INLET TEMP (°F)	IPW MODEL	DOMESTIC		BOILER			kBTU/H REQUIRED
			FLOW (GPM)	PRESSURE LOSS (PSI)	MAX. FLOW (GPM)	OUTLET TEMP (°F)	MAX. PRESSURE LOSS (PSI)	
60-160	165	IPW015DW	8	1	60	151	15	399
		IPW030DW	14	1	75	145	10	698
		IPW050DW	19.5	1	75	138	6	973
		IPW070DW	30	1	130	141	10	1,497
		IPW090DW	38	1	160	140	9	1,897
		IPW105DW	47	1	225	143	12	2,346
	170	IPW120DW	56	1	225	139	10	2,795
		IPW015DW	10	1	60	152	15	499
		IPW030DW	18	1	75	145	10	898
		IPW050DW	25	1	75	135	6	1,248
		IPW070DW	38.5	1	130	139	10	1,922
		IPW090DW	49	1	160	138	9	2,446
	180	IPW105DW	61	1	225	142	12	3,045
		IPW120DW	72	1	225	137	10	3,594
		IPW015DW	14.5	1	60	155	15	723
		IPW030DW	25	1	75	145	10	1,248
		IPW050DW	34	1	75	133	6	1,697
		IPW070DW	52	2	130	138	10	2,595
	190	IPW090DW	66.5	2	160	137	9	3,319
		IPW105DW	83	2	225	142	12	4,143
		IPW120DW	104	2	225	135	10	4,841
		IPW015DW	18	2	60	159	15	898
		IPW030DW	31	2	75	147	10	1,547
		IPW050DW	41.5	1	75	132	6	2,071
	200	IPW070DW	64	3	130	139	10	3,194
		IPW090DW	81.5	2	160	137	9	4,068
		IPW105DW	103	2	225	142	12	5,141
		IPW120DW	119	2	225	135	10	5,939
		IPW015DW	22	2	60	162	15	1,098
		IPW030DW	37	2	75	148	10	1,847
	210	IPW050DW	49	2	75	132	6	2,446
		IPW070DW	75	3	130	140	10	3,743
		IPW090DW	95	3	160	138	9	4,742
		IPW105DW	121	3	225	144	12	6,039
		IPW120DW	139	3	225	136	10	6,938
		IPW015DW	25	3	60	166	15	1,248
	220	IPW030DW	42	3	75	151	10	2,096
		IPW050DW	55.5	2	75	133	6	2,770
		IPW070DW	80	3	130	146	10	3,993
		IPW090DW	109	4	160	139	9	5,440
		IPW105DW	138	4	225	146	12	6,888
		IPW120DW	160	3	225	136	10	7,986
	220	IPW015DW	28.5	4	60	170	15	1,422
		IPW030DW	47	3	75	154	10	2,346
		IPW050DW	62	3	75	133	6	3,095
		IPW070DW	80	3	130	156	10	3,993
		IPW090DW	122	4	160	140	9	6,089
		IPW105DW	155	5	225	148	12	7,736
		IPW120DW	160	3	225	145	10	7,986

NOTE: Highlighted items are limited by the maximum flow velocity through the piping.



11 Sizing data

Table 11D Sizing Chart _ 60 - 180

DOMESTIC WATER INLET- OUTLET (°F)	BOILER WATER INLET TEMP (°F)	IPW MODEL	DOMESTIC		BOILER			kBTU/H REQUIRED
			FLOW (GPM)	PRESSURE LOSS (PSI)	MAX. FLOW (GPM)	OUTLET TEMP (°F)	MAX. PRESSURE LOSS (PSI)	
60-180	185	IPW015DW	7.5	1	60	169	15	449
		IPW030DW	13.5	1	75	162	10	808
		IPW050DW	19	1	75	153	6	1,138
		IPW070DW	29	1	130	157	10	1,737
		IPW090DW	37	1	160	156	9	2,216
		IPW105DW	46	1	225	159	12	2,755
	IPW120DW	54	1	225	155	10	3,235	
	190	IPW015DW	9.5	1	60	170	15	569
		IPW030DW	17.5	1	75	161	10	1,048
		IPW050DW	24	1	75	150	6	1,438
		IPW070DW	37	1	130	154	10	2,216
		IPW090DW	47.5	1	160	153	9	2,845
		IPW105DW	59	1	225	157	12	3,534
	IPW120DW	69.5	1	225	151	10	4,163	
	200	IPW015DW	13.5	1	60	172	15	808
		IPW030DW	23.5	1	75	161	10	1,408
		IPW050DW	32	1	75	146	6	1,917
		IPW070DW	49.5	1	130	152	10	2,965
		IPW090DW	63	1	160	151	9	3,774
		IPW105DW	79	2	225	156	12	4,732
	IPW120DW	91.5	2	225	149	10	5,481	
	210	IPW015DW	17	2	60	174	15	1,018
		IPW030DW	29	1	75	161	10	1,737
		IPW050DW	38.5	1	75	146	6	2,306
		IPW070DW	60	2	130	152	10	3,594
		IPW090DW	76	2	160	150	9	4,552
		IPW105DW	96	2	225	156	12	5,750
	IPW120DW	111	2	225	148	10	6,649	
	220	IPW015DW	20	2	60	178	15	1,198
		IPW030DW	34	2	75	163	10	2,037
		IPW050DW	45	2	75	144	6	2,696
		IPW070DW	69.5	2	130	153	10	4,163
		IPW090DW	88	2	160	151	9	5,271
		IPW105DW	111.5	3	225	158	12	6,679
	IPW120DW	129	3	225	148	10	7,727	
	230	IPW015DW	23	3	60	182	15	1,378
		IPW030DW	38.5	2	75	165	10	2,306
		IPW050DW	51	2	75	144	6	3,055
		IPW070DW	79	3	130	153	10	4,732
		IPW090DW	105	3	160	151	9	5,990
		IPW105DW	126	4	225	159	12	7,547
	IPW120DW	145	4	225	149	10	8,686	
	240	IPW015DW	26	3	60	185	15	1,557
		IPW030DW	43	3	75	167	10	2,576
		IPW050DW	56.5	3	75	145	6	3,384
		IPW070DW	80	3	130	162	10	4,792
		IPW090DW	111	4	160	152	9	6,649
		IPW105DW	141	4	225	161	12	8,446
	IPW120DW	160	4	225	150	10	9,584	

NOTE: Highlighted items are limited by the maximum flow velocity through the piping.



11 Sizing data *(continued)*

Table 11E Sizing Chart _ 40 - 120

DOMESTIC WATER INLET- OUTLET (°F)	BOILER WATER INLET TEMP (°F)	IPW MODEL	DOMESTIC		BOILER		kBTU/H REQUIRED	
			FLOW (GPM)	PRESSURE LOSS (PSI)	MAX. FLOW (GPM)	OUTLET TEMP (°F)		MAX. PRESSURE LOSS (PSI)
40-120	125	IPW015DW	7.5	1	60	114	15	300
		IPW030DW	13.5	1	75	110	10	541
		IPW050DW	19	1	75	104	6	762
		IPW070DW	29	1	130	106	10	1,163
		IPW090DW	37.5	1	160	105	9	1,504
		IPW105DW	46	1	225	108	12	1,845
	IPW120DW	55	1	225	105	10	2,206	
	130	IPW015DW	10.5	1	60	115	15	421
		IPW030DW	18	1	75	110	10	722
		IPW050DW	25.5	1	75	102	6	1,023
		IPW070DW	38.5	1	130	105	10	1,544
		IPW090DW	49.5	1	160	104	9	1,985
		IPW105DW	61.5	1	225	107	12	2,467
	IPW120DW	72	1	225	103	10	2,888	
	140	IPW015DW	15	1	60	119	15	601
		IPW030DW	26	1	75	111	10	1,043
		IPW050DW	35	1	75	101	6	1,404
		IPW070DW	54	2	130	106	10	2,166
		IPW090DW	69	2	160	104	9	2,768
		IPW105DW	86	2	225	108	12	3,450
	IPW120DW	101	2	225	103	10	4,051	
	150	IPW015DW	19	2	60	124	15	762
		IPW030DW	32.5	2	75	114	10	1,304
		IPW050DW	44	1	75	101	6	1,765
		IPW070DW	68	2	130	107	10	2,728
		IPW090DW	86.5	2	160	105	9	3,470
		IPW105DW	108	3	225	110	12	4,332
	IPW120DW	126	2	225	104	10	5,054	
	160	IPW015DW	23	3	60	128	15	922
		IPW030DW	39	2	75	117	10	1,564
		IPW050DW	52	2	75	102	6	2,086
		IPW070DW	80	3	130	109	10	3,209
		IPW090DW	102	3	160	107	9	4,091
		IPW105DW	129	4	225	112	12	5,174
	IPW120DW	149	3	225	105	10	5,977	
	170	IPW015DW	27	4	60	132	15	1,083
		IPW030DW	45.5	3	75	119	10	1,825
		IPW050DW	60.5	2	75	103	6	2,427
		IPW070DW	80	3	130	119	10	3,209
		IPW090DW	118	4	160	109	9	4,733
		IPW105DW	150	5	225	114	12	6,017
	IPW120DW	160	4	225	111	10	6,418	
	180	IPW015DW	31	5	60	137	15	1,243
		IPW030DW	52	4	75	122	10	2,086
		IPW050DW	68	3	75	104	6	2,728
		IPW070DW	80	3	130	129	10	3,209
		IPW090DW	134	5	160	110	9	5,375
		IPW105DW	160	6	225	121	12	6,418
	IPW120DW	160	4	225	121	10	6,418	
	190	IPW015DW	35	6	60	141	15	1,404
		IPW030DW	58	5	75	125	10	2,326
		IPW050DW	76	3	75	105	6	3,048
		IPW070DW	80	3	130	139	10	3,209
		IPW090DW	149	6	160	112	9	5,977
		IPW105DW	160	6	225	131	12	6,418
	IPW120DW	160	4	225	131	10	6,418	
	200	IPW015DW	39	7	60	145	15	1,564
		IPW030DW	64	6	75	128	10	2,567
		IPW050DW	80	4	75	111	6	3,209
		IPW070DW	80	3	130	149	10	3,209
		IPW090DW	160	7	160	116	9	6,418
		IPW105DW	160	6	225	141	12	6,418
	IPW120DW	160	4	225	141	10	6,418	
	210	IPW015DW	42.5	8	60	150	15	1,705
		IPW030DW	71	7	75	130	10	2,848
		IPW050DW	80	4	75	121	6	3,209
		IPW070DW	80	3	130	159	10	3,209
		IPW090DW	160	7	160	126	9	6,418
		IPW105DW	160	6	225	151	12	6,418
	IPW120DW	160	4	225	151	10	6,418	
	220	IPW015DW	46.5	10	60	155	15	1,865
		IPW030DW	76	8	75	135	10	3,048
		IPW050DW	80	4	75	131	6	3,209
		IPW070DW	80	3	130	169	10	3,209
		IPW090DW	160	7	160	136	9	6,418
		IPW105DW	160	6	225	161	12	6,418
	IPW120DW	160	4	225	161	10	6,418	

NOTE: Highlighted items are limited by the maximum flow velocity through the piping.



11 Sizing data

Table 11F Sizing Chart _ 40 - 140

DOMESTIC WATER INLET- OUTLET (°F)	BOILER WATER INLET TEMP (°F)	IPW MODEL	DOMESTIC		BOILER			kBTU/H REQUIRED
			FLOW (GPM)	PRESSURE LOSS (PSI)	MAX. FLOW (GPM)	OUTLET TEMP (°F)	MAX. PRESSURE LOSS (PSI)	
40-140	145	IPW015DW	7	1	60	133	15	350
		IPW030DW	13	1	75	127	10	651
		IPW050DW	18.5	1	75	119	6	926
		IPW070DW	28	1	130	122	10	1,403
		IPW090DW	36	1	160	121	9	1,804
		IPW105DW	44	1	225	124	12	2,205
	IPW120DW	53	1	225	120	10	2,656	
	150	IPW015DW	9.5	1	60	133	15	476
		IPW030DW	17	1	75	126	10	851
		IPW050DW	24	1	75	117	6	1,203
		IPW070DW	36.5	1	130	121	10	1,829
		IPW090DW	47	1	160	119	9	2,355
		IPW105DW	58	1	225	123	12	2,906
	IPW120DW	69	1	225	118	10	3,457	
	160	IPW015DW	13.5	1	60	136	15	676
		IPW030DW	23.5	1	75	127	10	1,177
		IPW050DW	32.5	1	75	115	6	1,628
		IPW070DW	50	1	130	120	10	2,505
		IPW090DW	64	1	160	118	9	3,207
		IPW105DW	80	1	225	123	12	4,008
	IPW120DW	93	1	225	117	10	4,660	
	170	IPW015DW	17	2	60	140	15	851
		IPW030DW	29.5	1	75	129	10	1,478
		IPW050DW	40	1	75	115	6	2,004
		IPW070DW	61.5	2	130	121	10	3,081
		IPW090DW	78.5	2	160	119	9	3,933
		IPW105DW	98	2	225	125	12	4,910
	IPW120DW	114	2	225	117	10	5,712	
	180	IPW015DW	21	2	60	143	15	1,052
		IPW030DW	35	2	75	131	10	1,754
		IPW050DW	47	1	75	115	6	2,355
		IPW070DW	72.5	2	130	122	10	3,633
		IPW090DW	92	2	160	120	9	4,610
		IPW105DW	116	3	225	126	12	5,812
	IPW120DW	134	2	225	118	10	6,714	
	190	IPW015DW	25	3	60	148	15	1,203
		IPW030DW	40.5	2	75	134	10	2,029
		IPW050DW	53.5	2	75	116	6	2,681
		IPW070DW	80	3	130	126	10	4,008
		IPW090DW	105	3	160	121	9	5,261
		IPW105DW	133	4	225	128	12	6,664
	IPW120DW	153	3	225	119	10	7,666	
	200	IPW015DW	27	4	60	153	15	1,353
		IPW030DW	45.5	3	75	136	10	2,280
		IPW050DW	60	2	75	116	6	3,006
		IPW070DW	80	3	130	136	10	4,008
		IPW090DW	118	4	160	123	9	5,912
		IPW105DW	150	5	225	130	12	7,516
	IPW120DW	160	3	225	126	10	8,017	
	210	IPW015DW	30.5	4	60	157	15	1,528
		IPW030DW	51	4	75	139	10	2,555
		IPW050DW	66.5	2	75	117	6	3,332
		IPW070DW	80	3	130	146	10	4,008
		IPW090DW	130.5	5	160	124	9	6,539
		IPW105DW	160	5	225	135	12	8,017
	IPW120DW	160	3	225	136	10	8,017	
	220	IPW015DW	34	5	60	160	15	1,704
		IPW030DW	56	4	75	141	10	2,806
		IPW050DW	72.5	3	75	118	6	3,633
		IPW070DW	80	3	130	156	10	4,008
		IPW090DW	143	6	160	126	9	7,165
		IPW105DW	160	5	225	145	12	8,017
	IPW120DW	160	3	225	146	10	8,017	

NOTE: Highlighted items are limited by the maximum flow velocity through the piping.



11 Sizing data *(continued)*

Table 11G Sizing Chart _ 40 - 160

DOMESTIC WATER INLET- OUTLET (°F)	BOILER WATER INLET TEMP (°F)	IPW MODEL	DOMESTIC		BOILER			kBTU/H REQUIRED
			FLOW (GPM)	PRESSURE LOSS (PSI)	MAX. FLOW (GPM)	OUTLET TEMP (°F)	MAX. PRESSURE LOSS (PSI)	
40-160	165	IPW015DW	7	1	60	150	15	420
		IPW030DW	12.5	1	75	144	10	751
		IPW050DW	18	1	75	135	6	1,082
		IPW070DW	27.5	1	130	138	10	1,653
		IPW090DW	35	1	160	138	9	2,104
		IPW105DW	43.5	1	225	141	12	2,615
	170	IPW120DW	52	1	225	136	10	3,125
		IPW015DW	9	1	60	151	15	540
		IPW030DW	16.5	1	75	142	10	991
		IPW050DW	23	1	75	132	6	1,382
		IPW070DW	35.5	1	130	136	10	2,134
		IPW090DW	45	1	160	135	9	2,705
	180	IPW105DW	56	1	225	139	12	3,366
		IPW120DW	66.5	1	225	133	10	3,997
		IPW015DW	13	1	60	153	15	781
		IPW030DW	22.5	1	75	142	10	1,352
		IPW050DW	31	1	75	128	6	1,863
		IPW070DW	47	1	130	135	10	2,825
	190	IPW090DW	60.5	1	160	133	9	3,636
		IPW105DW	75.5	1	225	138	12	4,538
		IPW120DW	88.5	1	225	131	10	5,319
		IPW015DW	16	1	60	156	15	961
		IPW030DW	28	1	75	143	10	1,683
		IPW050DW	37.5	1	75	127	6	2,254
	200	IPW070DW	57.5	2	130	135	10	3,456
		IPW090DW	73.5	2	160	132	9	4,418
		IPW105DW	92	2	225	139	12	5,530
		IPW120DW	107	2	225	130	10	6,431
		IPW015DW	19	2	60	160	15	1,142
		IPW030DW	32.5	2	75	145	10	1,953
	210	IPW050DW	43.5	1	75	127	6	2,615
		IPW070DW	67	2	130	135	10	4,027
		IPW090DW	85.5	2	160	133	9	5,139
		IPW105DW	107	3	225	140	12	6,431
		IPW120DW	124	2	225	131	10	7,453
		IPW015DW	22	2	60	164	15	1,322
	220	IPW030DW	37	2	75	148	10	2,224
		IPW050DW	49	1	75	128	6	2,945
		IPW070DW	76	3	130	136	10	4,568
		IPW090DW	96	3	160	134	9	5,770
		IPW105DW	122	3	225	142	12	7,333
		IPW120DW	140.5	3	225	131	10	8,445
		IPW015DW	24.5	3	60	168	15	1,473
		IPW030DW	41.5	2	75	150	10	2,494
		IPW050DW	55	2	75	127	6	3,306
		IPW070DW	80	3	130	142	10	4,808
		IPW090DW	108	4	160	135	9	6,491
		IPW105DW	136	4	225	144	12	8,174
	IPW120DW	156	3	225	132	10	9,376	

NOTE: Highlighted items are limited by the maximum flow velocity through the piping.



11 Sizing data

Table 11H Sizing Chart _ 40 - 180

DOMESTIC WATER INLET- OUTLET (°F)	BOILER WATER INLET TEMP (°F)	IPW MODEL	DOMESTIC		BOILER			kBTU/H REQUIRED
			FLOW (GPM)	PRESSURE LOSS (PSI)	FLOW (GPM)	OUTLET TEMP (°F)	MAX. PRESSURE LOSS (PSI)	
40-180	185	IPW015DW	8	1	60	168	15	490
		IPW030DW	12.5	1	75	160	10	876
		IPW050DW	18	1	75	150	6	1,262
		IPW070DW	27	1	130	154	10	1,893
		IPW090DW	35	1	160	153	9	2,454
		IPW105DW	43	1	225	157	12	3,015
	190	IPW120DW	51.5	1	225	151	10	3,611
		IPW015DW	9	1	60	168	15	631
		IPW030DW	16	1	75	159	10	1,122
		IPW050DW	22.5	1	75	146	6	1,578
		IPW070DW	34.5	1	130	151	10	2,419
		IPW090DW	44	1	160	150	9	3,085
	200	IPW105DW	55	1	225	154	12	3,857
		IPW120DW	65	1	225	148	10	4,558
		IPW015DW	12.5	1	60	169	15	876
		IPW030DW	21.5	1	75	158	10	1,508
		IPW050DW	29.5	1	75	142	6	2,069
		IPW070DW	45.5	1	130	149	10	3,190
	210	IPW090DW	58	1	160	147	9	4,067
		IPW105DW	72.5	1	225	153	12	5,084
		IPW120DW	85	1	225	145	10	5,960
		IPW015DW	15.5	1	60	172	15	1,087
		IPW030DW	26	1	75	159	10	1,823
		IPW050DW	35.5	1	75	140	6	2,489
	220	IPW070DW	55	1	130	148	10	3,857
		IPW090DW	69.5	1	160	146	9	4,873
		IPW105DW	87.5	2	225	153	12	6,135
		IPW120DW	102	2	225	143	10	7,152
		IPW015DW	18	2	60	176	15	1,262
		IPW030DW	30.5	1	75	160	10	2,139
	230	IPW050DW	41	1	75	139	6	2,875
		IPW070DW	63	2	130	149	10	4,417
		IPW090DW	80	2	160	146	9	5,610
		IPW105DW	101	2	225	154	12	7,082
		IPW120DW	117.5	2	225	143	10	8,239
		IPW015DW	20.5	2	60	179	15	1,437
	240	IPW030DW	34.5	2	75	162	10	2,419
		IPW050DW	46	1	75	139	6	3,225
		IPW070DW	71	2	130	149	10	4,978
		IPW090DW	90.5	2	160	146	9	6,346
		IPW105DW	114.5	3	225	155	12	8,029
		IPW120DW	132	3	225	143	10	9,256
	240	IPW015DW	23	3	60	183	15	1,613
		IPW030DW	38.5	2	75	164	10	2,700
		IPW050DW	51	2	75	139	6	3,576
		IPW070DW	79	3	130	150	10	5,539
		IPW090DW	100	3	160	147	9	7,012
		IPW105DW	127.5	4	225	156	12	8,940
IPW120DW	146	3	225	144	10	10,237		

NOTE: Highlighted items are limited by the maximum flow velocity through the piping.



12 Diagrams

Figure 12-1 Wiring Diagram - Electrical Control System Control Box

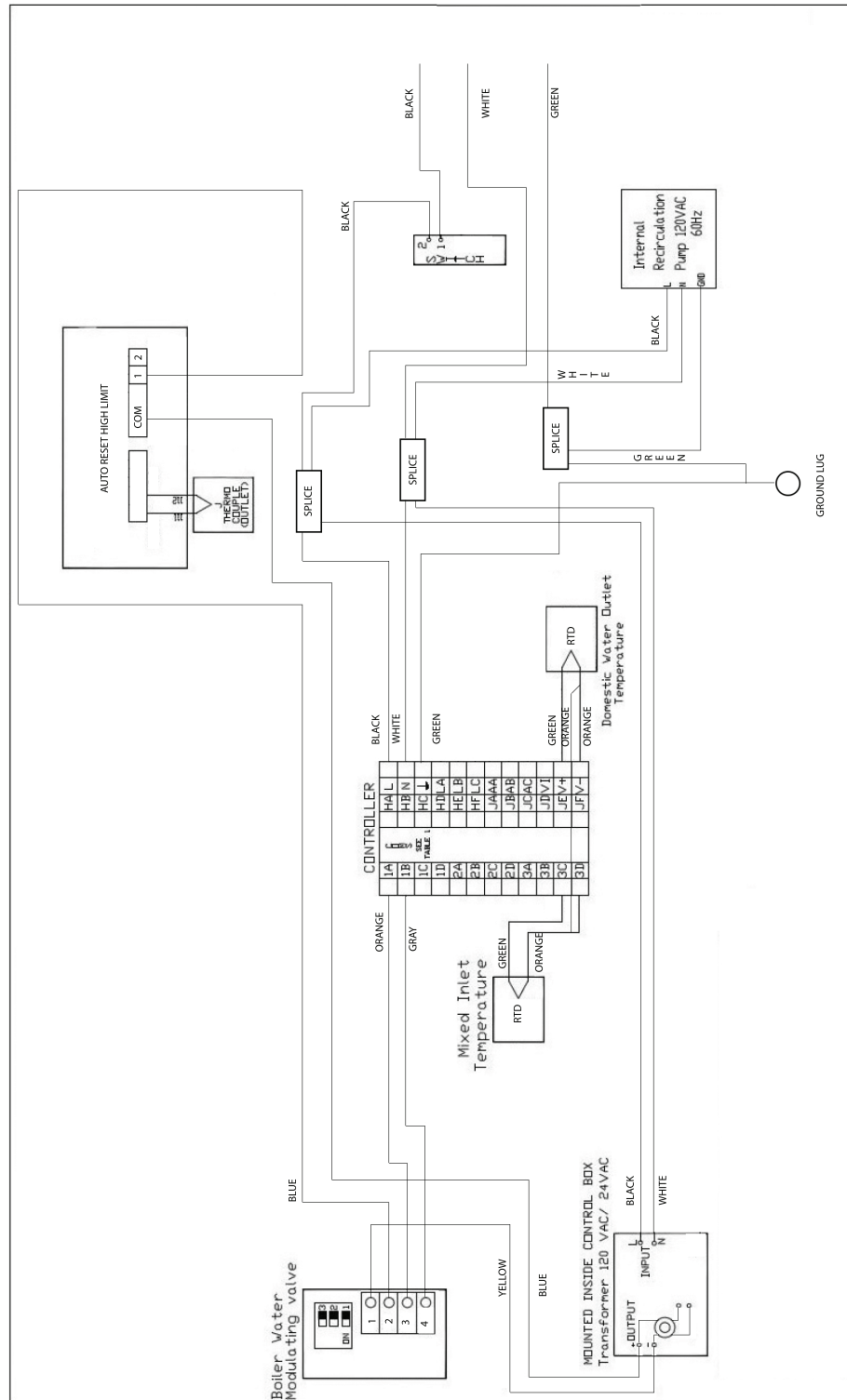

13 Replacement parts list

When ordering replacement parts:

When ordering replacement parts always give the following information:

1. Model, serial, and part number
2. Kit number
3. Parts description

Replacement Parts List

Item No.	Parts Description	Kit #	Model
1	Pump	100271293	IPW015DW-070DW
		100271294	IPW090DW-120DW
2	Control	100271295	IPW015DW-120DW
3	Sensor	100271296	IPW015DW-120DW
4	T & P Valve	100112873	IPW015DW-050DW
		100322498	IPW070DW-120DW
5	Modulating Valve	100271300	IPW015DW-070DW
		100271312	IPW090DW-120DW
6	Transformer	100208249	IPW015DW-120DW
7	High Limit <small>Note: High limit located inside the control panel.</small>	100402342	IPW015DW-120DW
8	Power Switch	100271316	IPW015DW-120DW

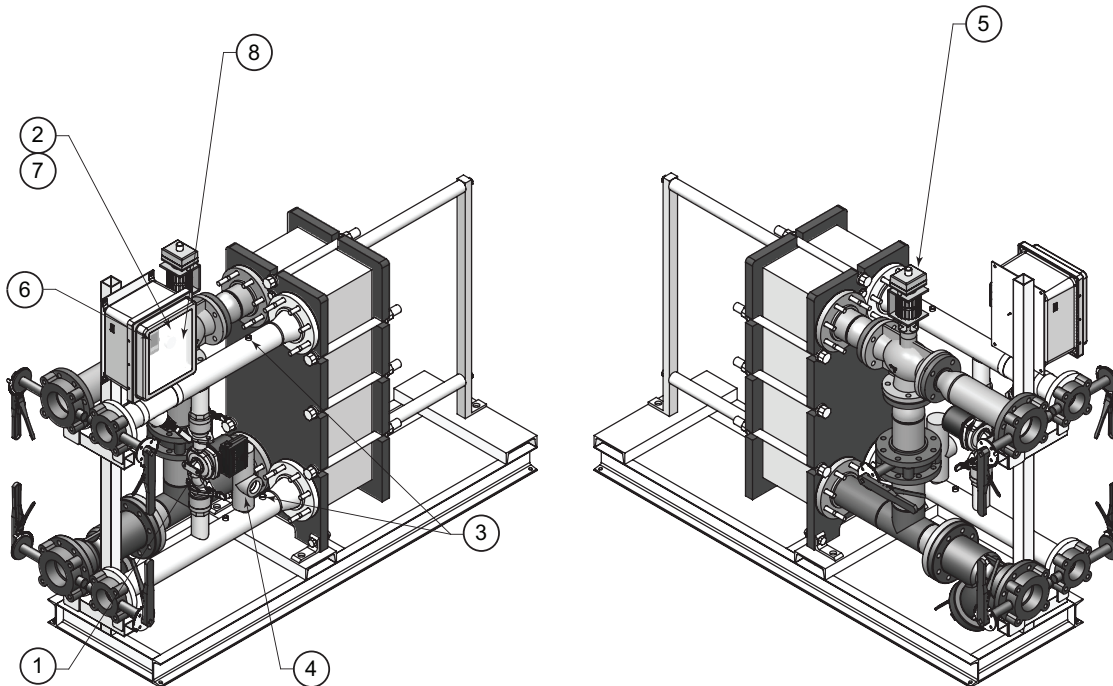

DIR #2000577459

Notes



Notes

Notes

Revision Notes: *Revision A (Process #3000002314_Change #500002513) initial release.*

Revision B (PCP# 3000003781 / CN# 500004056) reflects the addition of the Modbus chapter on pages 21 through 24.

Revision C (PCP #3000035575 / CN #500024078) reflects updates made to the manual and the addition of the Series break.

Revision D (PCP #3000048612 / CN #500035892) reflects an update to Memory Map input and holding register addresses on page 23.

Revision E (PCP #3000054593 / CN #500041076) reflects an update to the sizing charts on pages 31 through 38.

Revision F (PCP #3000060820 / CN #500046810) reflects the addition of a dielectric notice on page 8.

Revision G (PCP #3000065254 / CN #500051013) reflects updates to the table on page 6.

Revision H (PCP #3000070466 / CN #500055929) reflects updates to figures 4-5 and 6-1, as well as an update to the replacement parts list.