

Spec-Bar® Single Speed Rails

ASSEMBLY INSTRUCTIONS

See reverse side for Spec-Bar® Double Speed Rails.

CAUTION

INSPECT CONTENTS IMMEDIATELY AND FILE CLAIM WITH DELIVERING CARRIER FOR ANY DAMAGE.

SAVE YOUR BOX AND ALL PACKING MATERIALS.

YOU ARE RESPONSIBLE FOR DAMAGE TO YOUR UNIT IF RETURNED IMPROPERLY PACKED.

Parts List

#	Quantity	description
1	8	Screw, 1/4–20 x 1"
2	1	Bottle Stay
3	1	Bottle Support
4	1	Left Bracket
5	1	Right Bracket
6	1	Snap-On Clear Molding

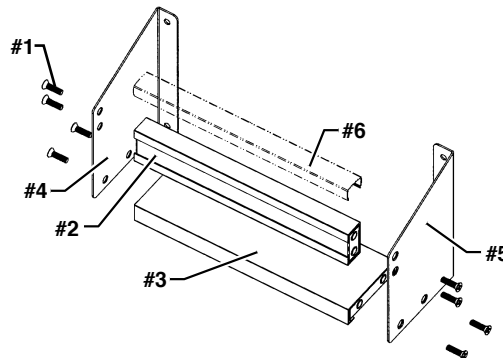

Step 1 - Assemble bottle support and one of the brackets.

- Lay bottle support with solid plastic side up.
- Insert screws through left or right bracket, as shown. DO NOT FULLY TIGHTEN.

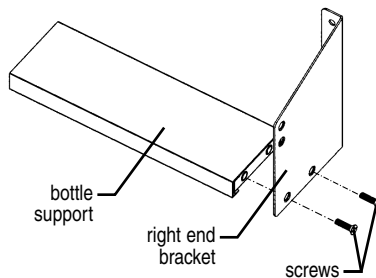

Step 2 - Install remaining bracket.

Insert screws through bracket, as shown. DO NOT FULLY TIGHTEN.

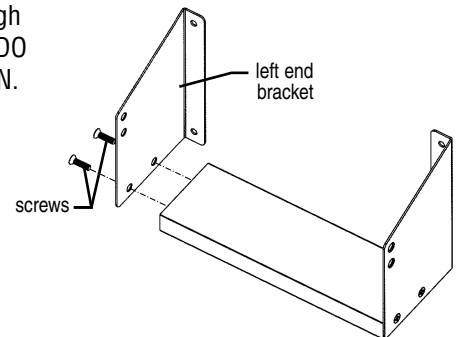

Step 3 - Install bottle stay.

IMPORTANT: Make sure the solid plastic surface faces the REAR of the speed rail.

Insert screws through brackets, as shown. DO NOT FULLY TIGHTEN.

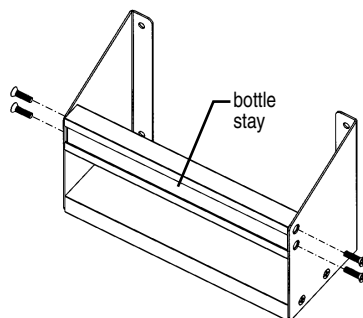

Step 4 - Affix bottle labels (not included) onto top of stay, as needed. Snap clear molding onto bottle stay.

Tighten all screws securely AFTER installing speed rail onto your equipment.

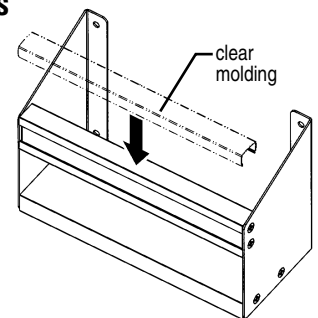

(End)

Spec-Bar® Double Speed Rails

ASSEMBLY INSTRUCTIONS

See reverse side for Spec-Bar® Single Speed Rails.

CAUTION

INSPECT CONTENTS IMMEDIATELY AND FILE CLAIM WITH DELIVERING CARRIER FOR ANY DAMAGE.

SAVE YOUR BOX AND ALL PACKING MATERIALS.

YOU ARE RESPONSIBLE FOR DAMAGE TO YOUR UNIT IF RETURNED IMPROPERLY PACKED.

Parts List

#	Quantity	description
1	16	Screw, 1/4–20 x 1"
2	2	Bottle Stay
3	2	Bottle Support
4	1	Left Bracket
5	1	Right Bracket
6	2	Snap-On Clear Molding

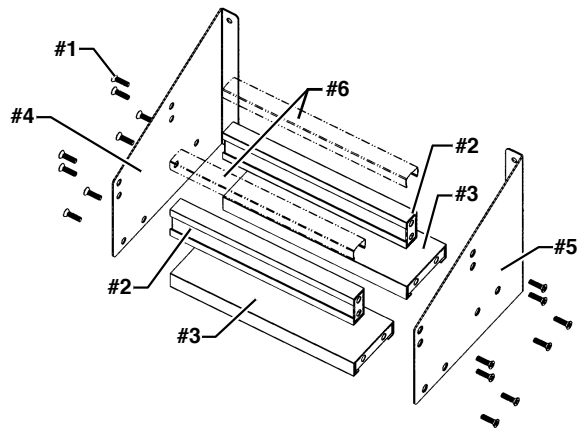

Step 1 - Assemble front bottle support and both end brackets.

- Position one of the two bottle supports, with solid plastic side up, between brackets at front set of holes.
- Insert screws through each bracket, as shown. DO NOT FULLY TIGHTEN.

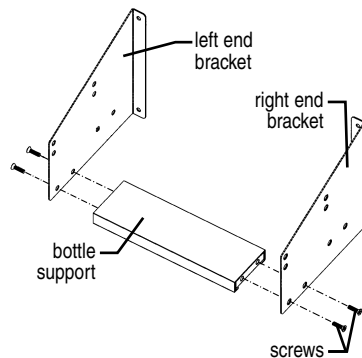

Step 2 - Install rear bottle support.

- Position remaining bottle support, with solid plastic side up, between brackets at rear set of holes.
- Insert screws through each bracket, as shown. DO NOT FULLY TIGHTEN.

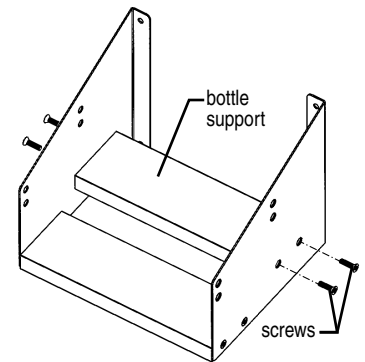

Step 3 - Install bottle stays.

IMPORTANT: Make sure the solid plastic surface of each bottle stay faces the REAR of the speed rail.

- Position one of the two bottle stays at rear set of holes.
- Insert screws through each bracket, as shown. DO NOT FULLY TIGHTEN.
- Repeat with remaining bottle stay set front set of holes.

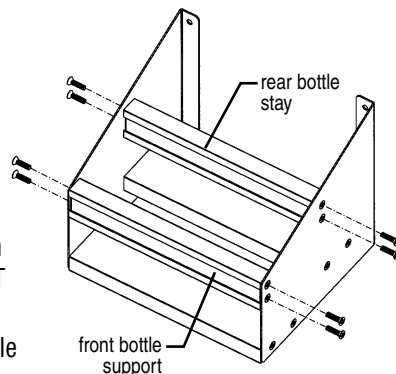

Step 4 - Affix bottle labels (not included) onto top of each stay, as needed. Snap clear molding onto each bottle stay.

Tighten all screws securely AFTER installing speed rail onto your equipment.

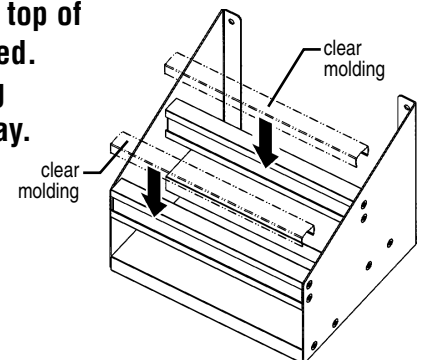

(End)

EAGLE
GROUP
Profit from the Eagle Advantage®

• 100 Industrial Boulevard, Clayton, Delaware 19938-8903 U.S.A.
• Phone: 302/653-3000 • 800/441-8440
• Fax: 302/653-2065 • www.eaglegrp.com

Eagle Foodservice Equipment, Eagle MHC, and SpecFAB® are divisions of Eagle Group. ©2021 by the Eagle Group