



FOOD EQUIPMENT

## Operating and Maintenance Instructions

Model series: STRIP HEATERS

6150-24 6150-36 6150-48 6150-60 6150-72 (Models with toggle switch)  
6151-24 6151-36 6151-48 6151-60 6151-72 (Models with thermostat)

ALL MODELS FOLLOWED BY -CP INCLUDE CORD AND PLUG  
ALL MODELS FOLLOWED BY -D ARE DUAL STRIP HEATER UNITS

### INTRODUCTION

1. Please read instructions before using this appliance.
2. When using this appliance, basic precautions should always be followed to reduce the risk of fire, electric shock and injury.
3. Clean machine thoroughly before and after all uses following cleaning instructions below.

### ELECTRICAL REQUIREMENTS

1. Wire warmer into a grounded circuit with correct voltage and sufficient power capacity. Refer to the product label (serial plate) on the warmer for voltage and wattage requirements.
2. **All electrical connections must be made according to local codes by a licensed electrician.**

### SAFETY INSTRUCTIONS

1. **Warning!** All power must be disconnected at power source before any service procedure is performed.
2. This appliance is hot when in use. To avoid burns, do not let bare skin touch hot surfaces. Keep combustible materials, such as drapes and other furnishings, away from appliance.
3. Extreme caution is necessary when any appliance is used by or near children and whenever the appliance is left unattended.
4. Always turn the power off at the circuit breaker before cleaning, adjusting or maintaining this machine.
5. Do not operate any appliance after it malfunctions, has been dropped, or damaged. Return appliance to an authorized service facility for examination, electrical or mechanical adjustment, or repair.
6. Do not use outdoors. This appliance is not intended for use in wet or moist locations. Never locate appliance where it may fall into water.
7. To prevent a possible fire, it is recommended that the unit is installed above a non-combustible surface.
8. This appliance has electrical parts. Do not use it in areas where gasoline, paint, or flammable liquids are used or stored.

### INSTALLATION

1. All 6150 and 6151 models should be wired per **ELECTRICAL REQUIREMENTS** above.
2. Use MOUNTING BRACKET supplied with the warmer. Install with the following clearances: 9" min. between end of unit and any wall, 12" min. between side of unit and any wall, 16" min. between bottom of unit and counter, and 1 7/8" min. between top of unit and overhead surface.
3. This unit radiates heat when in use therefore we recommend that the unit be installed above a non-combustible surface.
4. A wire leg stand (part number 66099) is available for counter use.
5. Use Only Copper Wire suitable for 90° C (194° F).
6. If warmer fails to work properly when first operated call NEMCO customer service at 1-800-782-6761.

### OPERATION

1. Place food products in a pan located directly under the warmer for best results.
2. Turn warmer off when not in use.

### CLEANING

**NOTE:** Proper maintenance plays an important part in the life span and functioning of the warmer.

1. Turn warmer off before cleaning.
2. Do not immerse in water or other liquid. Avoid splashing water into unit.
3. The housing and reflectors are made of anodized aluminum and aluminized steel, which can be kept clean by use of a damp sponge and soap solution.

### TROUBLESHOOTING

No Heat	Check that power switch is turned "ON".
	Check power at heater.
Unit Blows Fuse or Circuit Breaker	Check to make sure circuit is not overloaded.



**PARTS DRAWING AND WIRING DIAGRAMS**  
**FOR 6150-( ) & 6151-( ) BAR HEATERS**

NOTE: BAR WARMER IS DRAWN UPSIDE DOWN

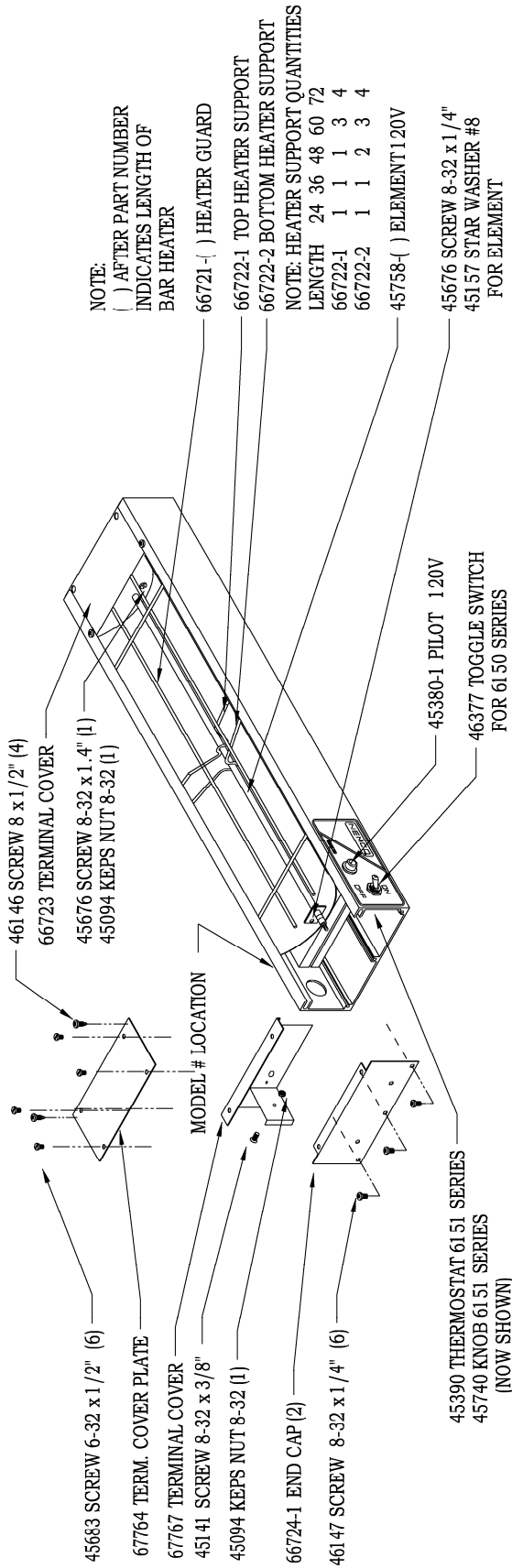

NOTE:  
 -CP MODELS INCLUDE THE PARTS NOT SHOWN  
 (3) 47683, WIRENUT  
 (1) 47661, CORD (FOR -24-CP THRU -60-CP MODELS)  
 (1) 47885, CORD (FOR THE -72-CP MODELS)

NOTE:  
 ( ) AFTER PART NUMBER INDICATES LENGTH OF BAR HEATER  
 66721-( ) HEATER GUARD  
 66722-1 TOP HEATER SUPPORT  
 66722-2 BOTTOM HEATER SUPPORT  
 NOTE: HEATER SUPPORT QUANTITIES  
 LENGTH 24 36 48 60 72  
 66722-1 1 1 1 3 4  
 66722-2 1 1 2 3 4  
 45758-( ) ELEMENT 120V

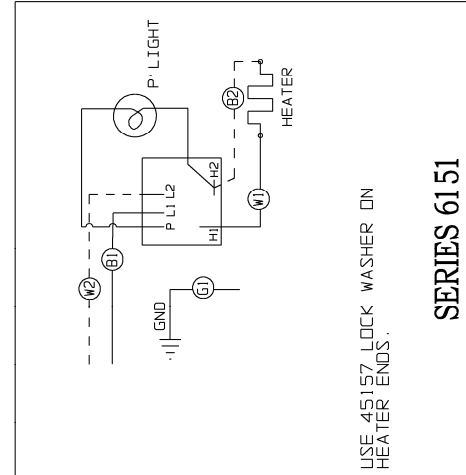
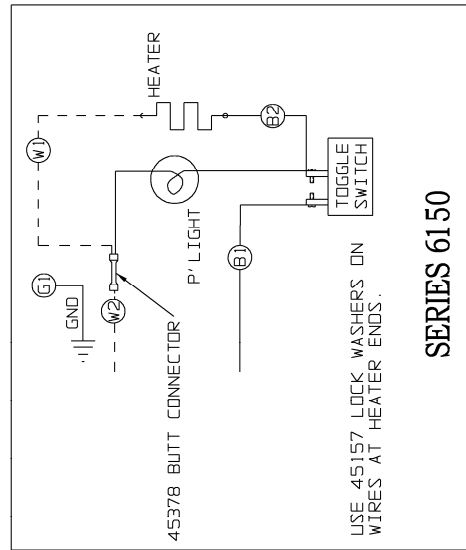

FOLLOWING NOT SHOWN  
 66014 HANGER BRACKET (2)  
 45683 SCREW 6-32 x 1/2" (4)  
 46351 ROMEX CONNECTOR  
 45787 WIRE NUT (3)  
 NOTE: 66099 LEGS ARE AVAILABLE FOR COUNTER TOP USE

WIRE SCHEMATICS