

24" 224-Can Beverage Fridge Built-in or Freestanding Design

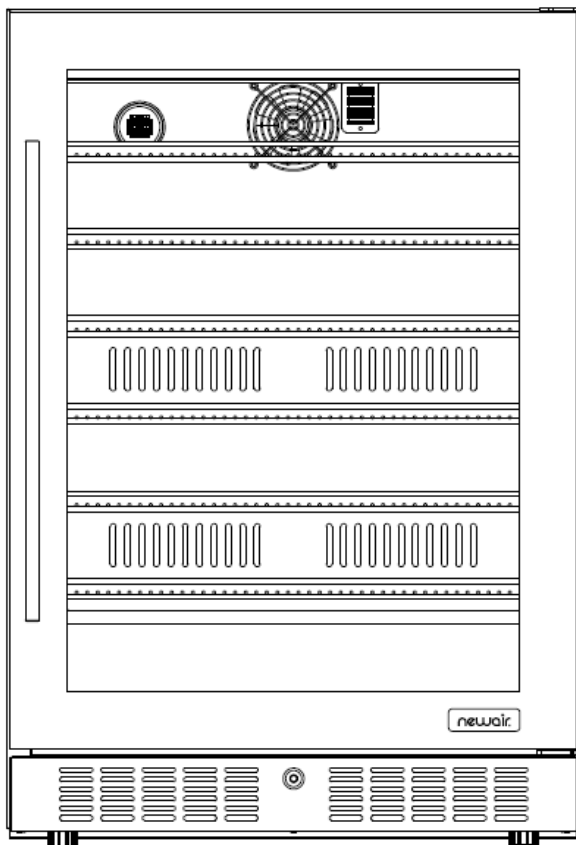

OWNERS MANUAL

Read and save these instructions.



Intertek
Manual v1.0

READ AND SAVE THESE INSTRUCTIONS.

TABLE OF CONTENTS

Register Your Product Online.....	3
Safety Information & Warnings	4
Parts List.....	7
Assembly & Installation	8
Operating Instructions	17
Cleaning & Maintenance.....	19
Troubleshooting.....	21
Limited Manufacturer's Warranty	23

SPECIFICATIONS

MODEL No.	NBC224SS00
VOLTAGE:	120V
CURRENT:	1.3A
FREQUENCY:	60Hz
POWER CONSUMPTION:	100W
CAN CAPACITY:	224 cans
STORAGE CAPACITY:	5.72 cubic feet
TEMPERATURE RANGE:	37°F - 65°F
REFRIGERANT:	R600a

REGISTER YOUR PRODUCT ONLINE

Register Your NewAir Product Online Today!

Take advantage of all the benefits product registration has to offer:



Service and Support

Diagnose troubleshooting and service issues faster and more accurately



Recall Notifications

Stay up to date for safety, system updates and recall notifications



Special Promotions

Opt-in for NewAir promotions and offers

Registering your product information online is safe & secure and takes less than 2 minutes to complete:

newair.com/register

Alternatively, we recommend you attach a copy of your sales receipt below and record the following information, located on the manufacturer's nameplate on the rear of the unit. You will need this information if it becomes necessary to contact the manufacturer for service inquiries.

Date of Purchase: _____

Serial Number: _____

Model Number: _____

SAFETY INFORMATION & WARNINGS

Your safety and the safety of others are very important to us.



Always read and follow all safety messages. All safety messages will follow the Safety Alert Symbol and either the words “**DANGER**”, “**WARNING**” or “**CAUTION**”.

DANGER: Danger means that failure to heed this safety statement may result in severe injury or death.

WARNING: Warning means that failure to heed this safety statement may result in extensive product damage, serious injury, or death.

CAUTION: Caution means that failure to heed this safety statement may result in minor or moderate personal injury, or property or equipment damage.

All safety messages will alert you to know what the potential hazard is, tell you how to reduce the chance of injury, and let you know what can happen if the instructions are not followed.



IMPORTANT SAFEGUIDES

Before the appliance is used, it must be properly positioned and installed as described in this manual, please read the manual carefully. To reduce the risk of fire, electrical shock or injury when using the appliance, follow basic precaution, including the following:

- Plug into a grounded 3-prong outlet, do not remove grounding prong, do not use an adapter or extension cord.
- It is recommended that a separate circuit serving only your appliance be used. Do not use outlets that can be turned off by a switch or pull chain.
- Never clean appliance parts with flammable fluids or use them in the vicinity of this appliance, since the fumes can create a fire hazard or explosion.
- Before proceeding with cleaning and maintenance operations, make sure the power line of the unit is disconnected. Failure to do so can result in electrical shock or death.

- Do not connect or disconnect the plug when your hands are wet.
- Do not attempt to repair or replace any part of your appliance unless it is specifically recommended in this manual. It is hazardous for anyone other than an authorized Service Person to carry out servicing or repairs to this appliance.
- This appliance is CFC- and HFC-free and contains small quantities of Isobutane (R600a) which is environmentally friendly, but flammable. It does not damage the ozone layer, nor does it increase the greenhouse effect. Care must be taken during transportation and setting up of the appliance that no parts of the cooling system are damaged. Leaking coolant can ignite and may damage the eyes.
- In the event of any damage:
 - Avoid open flames and anything that creates a spark,
 - Disconnect from the electrical power line,
 - Air the room in which the appliance is located for several minutes, and
 - Contact the Service Department for advice.
- The more coolant there is in an appliance, the larger the room it should be installed in. In the event of a leakage, if the appliance is in a small room, there is the danger of combustible gases building up. For every ounce of coolant, at least 325 cubic feet of room space is required. The amount of coolant in the appliance is stated on the data plate on the back of the appliance.
- Take serious care when handling, moving, and using the appliance to avoid either damaging the refrigerant tubing or increasing the risk of a leak.



FOLLOW WARNING CALL OUTS BELOW ONLY WHEN APPLICABLE TO YOUR MODEL

- Use two or more people to move and install the appliance. Failure to do so can result in injury.
- To ensure proper ventilation for your appliance, the front of the appliance must be completely unobstructed.
- Choose a well-ventilated area with temperatures above 60°F (16°C) and below 90°F (32°C).
- The appliance should not be located next to ovens, grills or other sources of high heat.
- The appliance must be installed with all electrical, water and drain connections in accordance with state and local codes. A standard electrical supply (115 V AC only, 60 Hz), properly grounded in accordance with the National Electrical Code and local codes and ordinances is required.
- Do not bend, twist or pinch the power supply cord of appliance.
- The fuse (or circuit breaker) size should be 15 amperes.
- It is important for the appliance to be leveled in order to work properly. You may need to make several adjustments to level it.
- Never allow children to operate, play with or crawl inside the appliance.
- Do not use solvent-based cleaning agents or abrasives on the interior. These cleaners may damage or discolor the interior.
- Do not use this appliance for other than its intended purpose.

Risk of child entrapment!



To prevent entrapment and suffocation hazard, do not leave children unattended when in the vicinity of the appliance.

Before discarding your old refrigerator:

- **take off the doors.**
- **leave the shelves in place so that children may not easily climb inside.**

- SAVE THESE INSTRUCTIONS -

PARTS LIST

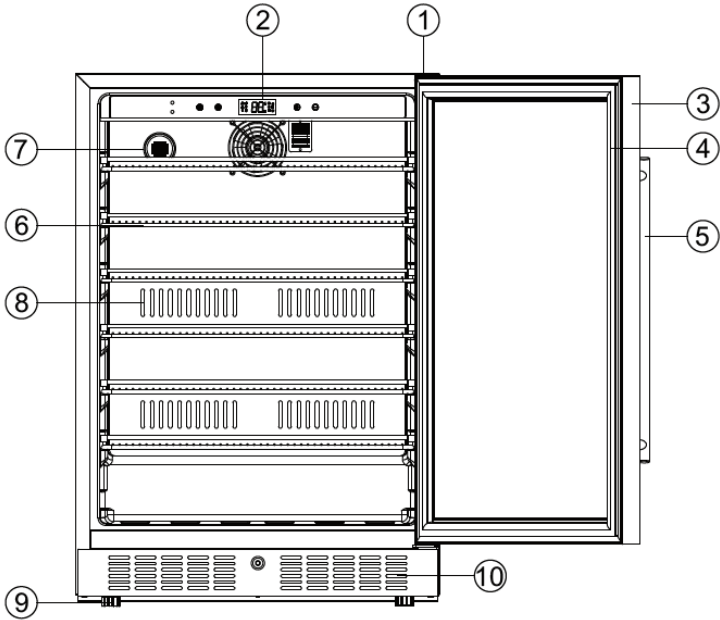
NBC224SS00 – 24" Built-in Premium 224-Can Beverage Fridge

1	Upper Hinge
2	Control Panel
3	Door
4	Door Seal
5	Door Handle
6	Black Wire Shelf
7	Carbon Filters
8	Air Channel Plate
9	Adjustable Feet
10	Vent Kick Plate

ASSEMBLY & INSTALLATION

ELECTRICAL CONNECTION

WARNING

This appliance should be properly grounded for your safety. The power cord of this appliance is equipped with a three-prong plug which mates with standard three prong wall outlets to minimize the possibility of electrical shock.

Do not under any circumstances cut or remove the third ground prong from the power cord supplied. For personal safety, this appliance must be properly grounded.

This appliance requires a standard three-prong 115/120 Volt AC ~/60Hz electrical ground wall outlet. Have the wall outlet and circuit checked by a qualified electrician to make sure the outlet is properly grounded. When a standard 2-prong wall outlet is encountered, it is your responsibility and obligation to have it replaced with a properly grounded 3-prong wall outlet.

The cord should be secured behind the appliance and not left exposed or dangling to prevent accidental injury.

The appliance should always be plugged into its own individual electrical outlet which has a voltage rating that matches the rating label on the appliance. This provides the best performance and also prevents overloading house wiring circuits that could be a fire hazard from overheating. Never unplug the appliance by pulling the power cord. Always grip the plug firmly and pull straight out from the receptacle. Repair or replace immediately all power cords that have become frayed or otherwise damaged. Do not use a cord that shows cracks or abrasion damage along its length or at either end. When moving the appliance, be careful not to damage the power cord.

Improper use of the grounded plug can result in the risk of electrical shock. If the power cord is damaged, have it replaced by a service center authorized by NewAir, LLC.

EXTENSION CORD

Because of potential safety hazards under certain conditions, it is strongly recommended that you do not use an extension cord with this appliance. However, if you must use an extension cord it is absolutely necessary that it be a UL/CUL-Listed, 3-wire grounding type appliance extension cord having a grounding type plug and outlet and that the electrical rating of the cord be 115 volts and at least 10 amperes.

BEFORE USING YOUR APPLIANCE

Remove the exterior and interior packing; check to be sure you have all the following parts:

Model NBC224SS00

- 1 Instruction Manual
- 6 Black Wire Shelves
- 1 Door Handle

- Before connecting this appliance to the power source, let it stand upright for approximately 24 hours. This will reduce the possibility of a malfunction in the cooling system from handling during transportation.
- Clean the interior surface with lukewarm water using a soft cloth.
- The appliance is specially designed for wine and/or beverage storage; please do not put in other types of food or perishable goods.

INSTALLATION OF YOUR APPLIANCE

- This appliance is designed for freestanding or built-in (fully recessed) installation.
- Place your appliance on a floor that is strong enough to support it when it is fully loaded. To level your appliance, adjust the front leveling legs at the bottom of the appliance.
- Locate the appliance away from direct sunlight and sources of heat (stove, heater, radiator, etc.). Direct sunlight may affect the acrylic coating and heat sources may increase electrical consumption. Extremely cold ambient temperatures may also cause the unit not to perform properly.
- Avoid locating the unit in moist areas.

BUILT-IN CABINET INSTRUCTIONS

This unit is designed for both built-in and freestanding installation. If you plan to use this unit in a built-in application, please follow the requirements shown below. Be sure that airflow under the appliance is not blocked.

Cabinet Opening Dimensions		
	IN (min)	CM (min)
Width	23.8"	60.5 cm
Depth	25.2"	64.0 cm
Height	34.5"	87.6 cm

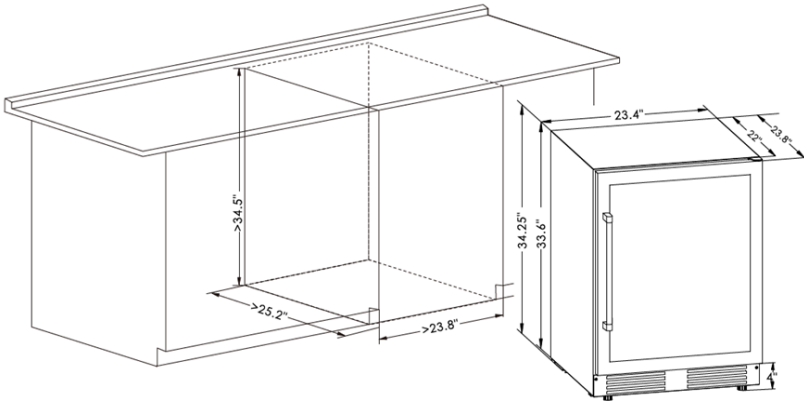

INSTALLING STAINLESS STEEL HANDLE

This fridge includes two stainless steel handles that are not installed by the factory. To install the handle please follow these instructions:

1. Pull away the door gasket in the area where the handle is to be installed, as shown in the first illustration below. The gasket is easily displaced by hand, no tools are necessary.
2. Align the handle with the screws pre-installed on the backside of the door. Tighten the screws using a Phillips head screwdriver until the handle sets both flush and secured tightly against the door frame. (DO NOT over-tighten as this will cause damage to the handle assembly).
3. Replace the door gasket to its original position.

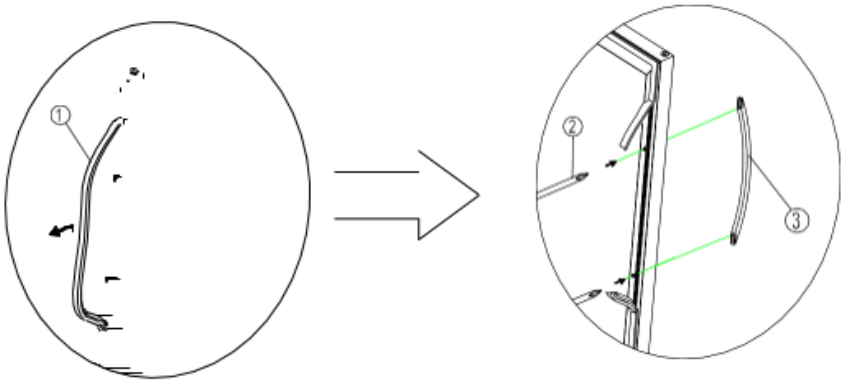

- ① Gasket
- ② Screwdriver
- ③ S/S handle

REVERSING STAINLESS STEEL DOOR

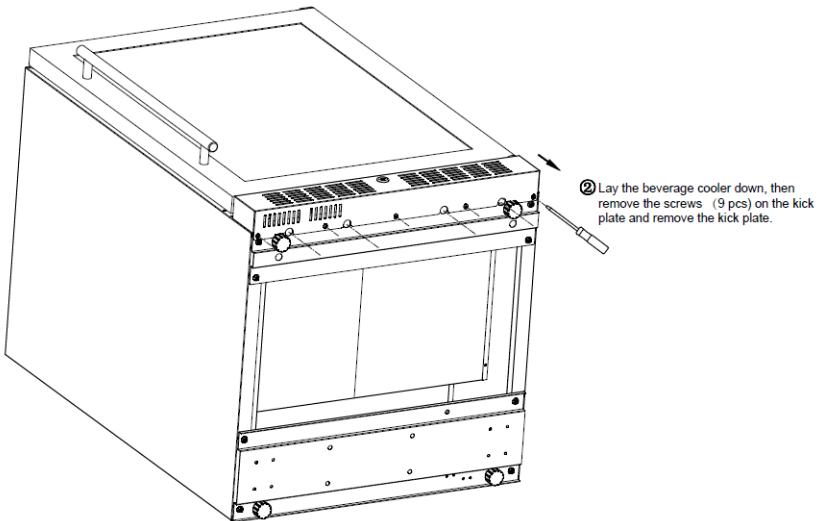
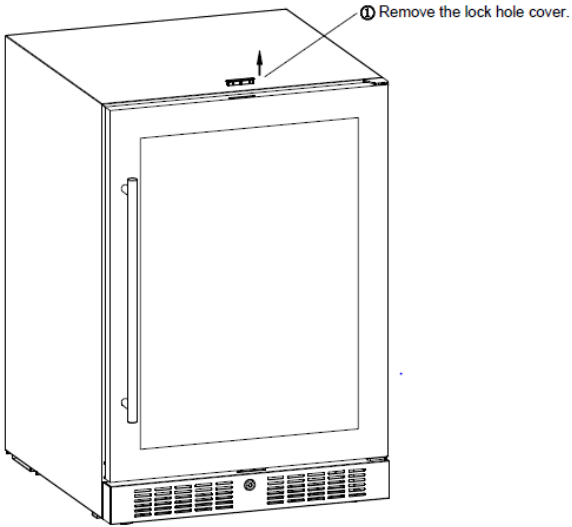

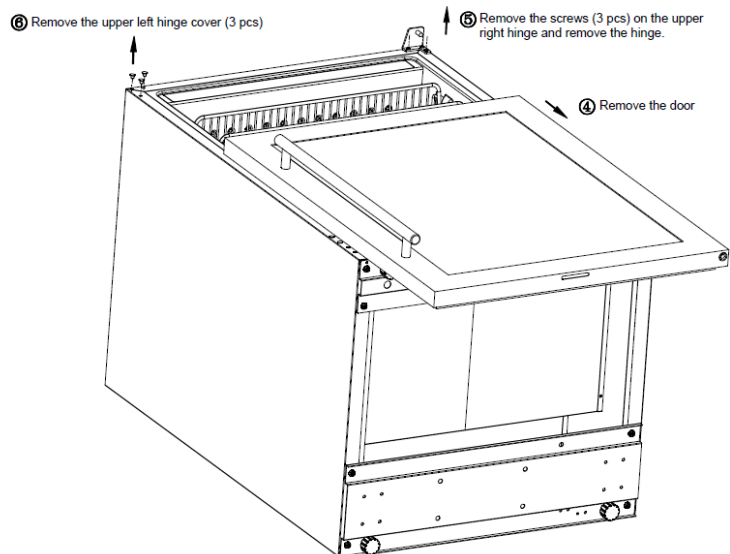
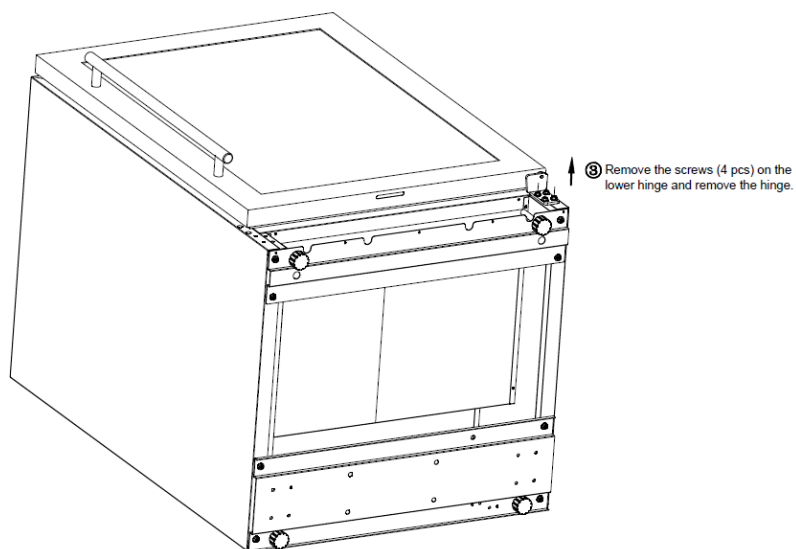

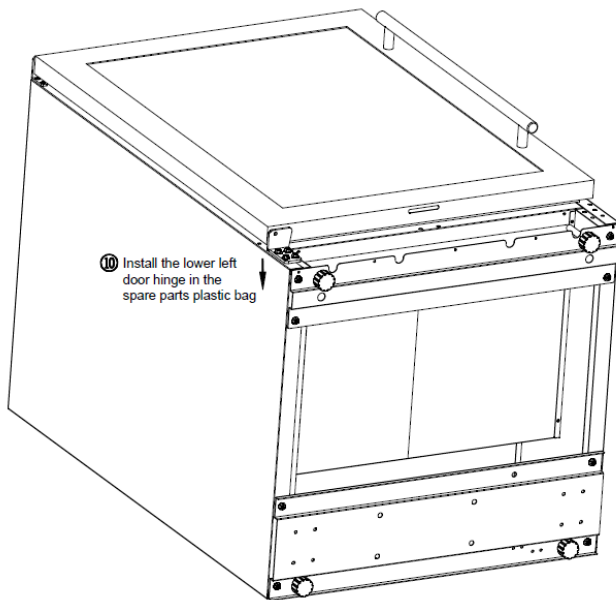
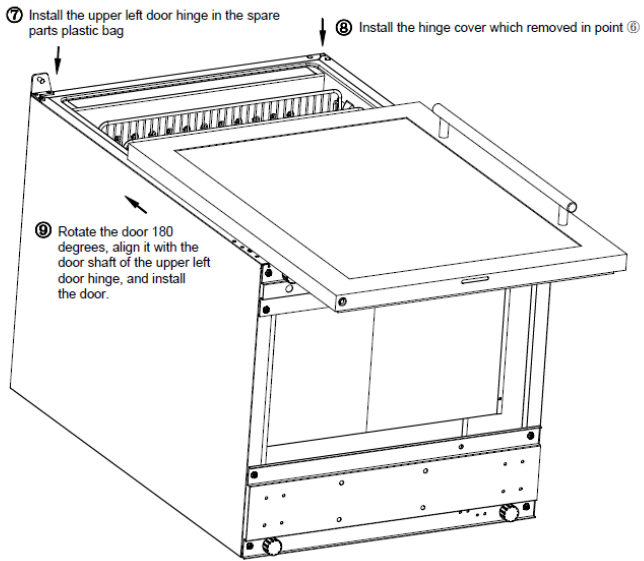

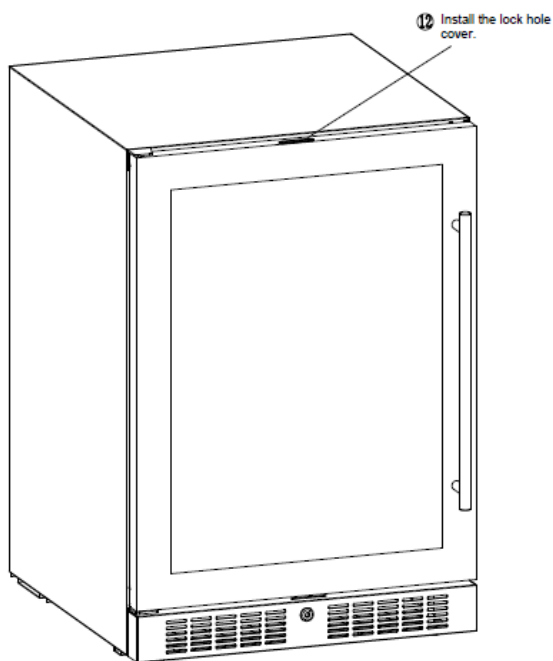
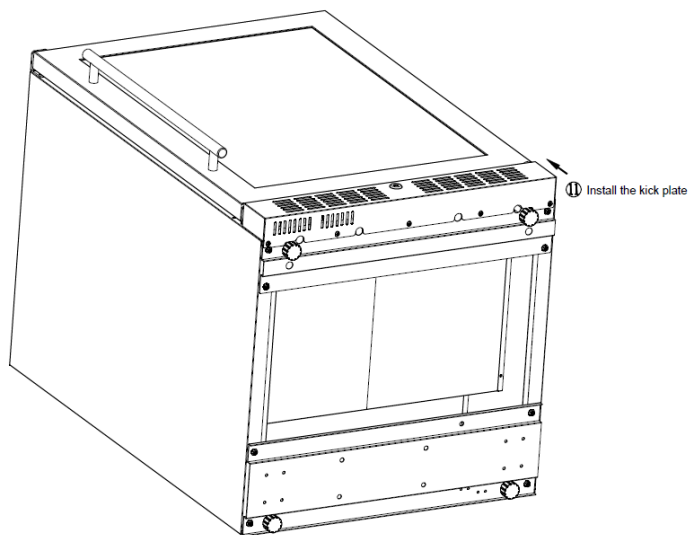

WIRINGDIAGRAM

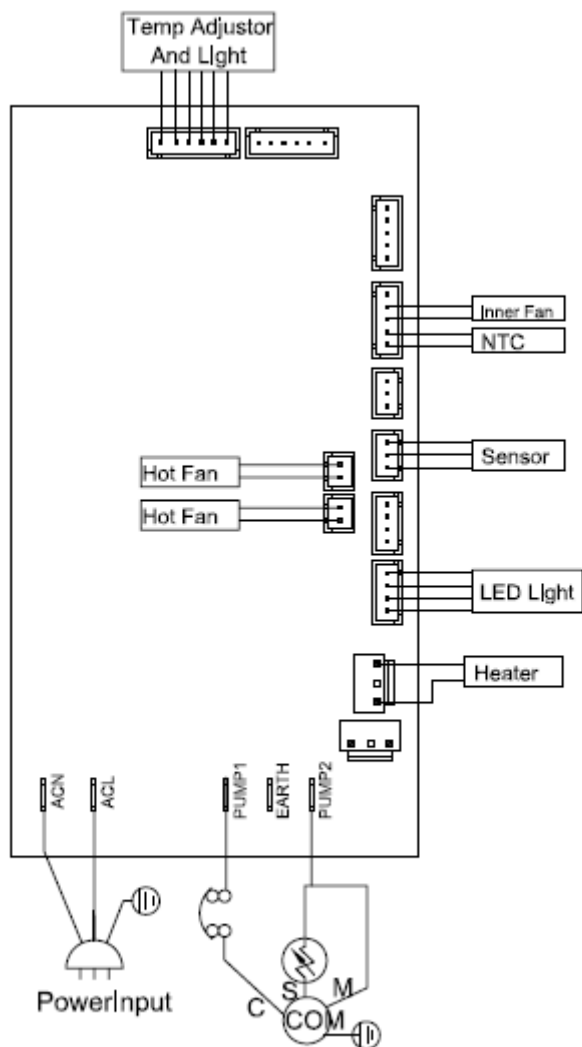
**Electrocircuit Line Diagram**

OPERATING INSTRUCTIONS

It is recommended that you install the appliance in a place where the ambient temperature is between 61°- 100° F (16°-38° C). If the ambient temperature is higher or lower than recommended temperatures, the performance of the unit may be affected. For example, placing your unit in extremely cold or hot conditions may cause interior temperatures to fluctuate and the stated range of 37°-65°F (5°-18° C) may not be reached.

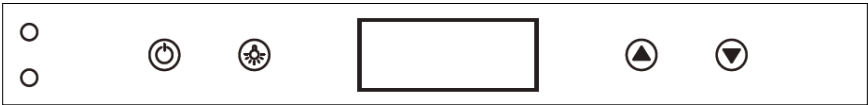

CONTROL PANEL









ON/OFF POWER

Press and hold  for 3 seconds on control panel to turn on or turn off the fridge. When turned off, the appliance will stop working and completely shut down.



LIGHT SETTING



There are 3 color for the light (white, blue and amber). Press  to change the color. Also, there are 3 light modes. Press and hold  for 3 seconds to select a light mode.

1. Light on and off mode: The default light setting is controlled by a sensor and the LCD screen will show . When the door is opened, the light will turn on automatically, when door is closed, the light will be turned off.
2. Light on model: Press and hold  for 3 seconds to enter light on mode. When in this mode, the  LCD screen will display  and the light will always be on.







3. Multi-color LED with auto color change mode: press and hold  for 3 seconds to enter light on mode. When in this mode, the LCD screen will not display  or  , and the lights will automatically change colors constantly.

TEMPERATURE SETTING

Press  or  to adjust the temperature of the appliance. Each press on the button will alter the temperature by 1°F or 1°C.

Press  and  together and hold for 3 seconds to change temperature display from Celsius to Fahrenheit or from Fahrenheit to Celsius.

WARNING SYSTEM

1. Door open alarm: When door has been open for over 5 minutes, door open alarm will be on and the LCD screen will display  and beep 3 times every 5 seconds. Press any key or close the door to stop the alarm.
2. Low temperature alarm: When inside temperature is below 35.6°F (2°C) for over 3 hours, it will beep to alarm and LCD screen will display    . Press any key to stop the beeping alarm.
3. High temperature alarm: When inside temperature is above 77°F (25°C) for over 6 hours, it will beep to alarm and LCD screen will display    . Press any key to stop the beeping alarm.

CLEANING & MAINTENANCE

CLEANING YOUR APPLIANCE

- Turn off the power, unplug the appliance, and remove all items including shelves.
- Wash the inside surfaces with a warm water and baking soda solution. The solution should be about 2 tablespoons of baking soda to a quart of water.
- Wash the shelves with a mild detergent solution.
- Wring excess water out of the sponge or cloth when cleaning area of the controls, or any electrical parts.
- Wash the outside cabinet with warm water and mild liquid detergent. Rinse well and wipe dry with a clean soft cloth.
- Do not use steel wool or steel brush on the stainless steel. These will contaminate the stainless steel with steel particles and rusting may occur.

MOVING YOUR APPLIANCE

- Remove all items.
- Securely tape down all loose items (shelves) inside your appliance.
- Tape the door shut.
- Be sure the appliance stays secure in the upright position during transportation. To avoid denting or scratching protect the appliance with a cover if possible.

ENERGY-SAVING TIPS

- The appliance should be located in the coolest area of the room, away from heat producing appliances, and out of direct sunlight.

CARBON FILTRATION SYSTEM

Your wine is a living object that breathes through the cork of its bottle. In order to preserve the quality and taste of your fine wines, they must be stored at the ideal temperature and ambient conditions.

Your cellar is equipped with an active carbon filtration system to ensure air purity and cooling efficiency, and to maintain an odor-free cabinet for the storage of your wine. The filter assembly is located at the rear panel inside your fridge.

Keep in mind, that this filter must be changed every 12 months.

To replace your filter:

1	Remove the cans stored on the shelves in front of the filter.	
2	Remove the shelves and set aside to be replaced once you have changed the filter.	
3	Hold the filter and turn it at 90 degrees in a counterclockwise direction and then pull it out.	
4	Remove the existing filter and replace with a new one.	
5	Put the new filter into the hole and then turn the filter 90 degrees in a clockwise direction.	

TROUBLESHOOTING

You can solve many common problems easily, saving you the cost of a possible service call. Try the suggestions below to see if you can solve the problem before calling the service technician.

Problem	Possible Causes and Solution
Appliance is not running	<ul style="list-style-type: none"> • The appliance is not plugged in. • The appliance is not turned on. • Check voltage of the installation • Check if the circuit breaker or the fuse are damaged.
Appliance is not cold enough	<ul style="list-style-type: none"> • Check the temperature control setting. • Check if ambient temperature is beyond appliance operating temperature. • The door is opened too frequently. • The door is not closed properly. • The door is not sealing properly. • Insufficient free space around the appliance.
The compressor starts and stops frequently	<ul style="list-style-type: none"> • The external temperature is high. • A large quantity of bottles has been put into the cellar. • The appliance is opened frequently. • The door is not properly closed. • The cellar has not been correctly set.
LED lights do not operate	<ul style="list-style-type: none"> • The appliance is not plugged in. • The fuse is damaged. • LED lights are broken. • The light switch is off.
Vibration	<ul style="list-style-type: none"> • Check and ensure that the appliance is level
The appliance makes a lot of noise	<ul style="list-style-type: none"> • The rattling noise may come from the flow of the refrigerant, which is normal. • At the end of a cooling cycle, you can hear the noise of water circulating. • Expansion and contraction of the internal walls may cause a cracking sound. • The appliance is not level. • Check if fan is in good condition.

Problem	Possible Causes and Solution
The door does not close properly	<ul style="list-style-type: none">• The appliance is not level.• The door seal is dirty or damaged.• The shelves are not positioned correctly.• A part of the contents is preventing the door from closing.

LIMITED MANUFACTURER'S WARRANTY

This appliance is covered by a limited manufacturer's warranty. For one year from the original date of purchase, the manufacturer will repair or replace any parts of this appliance that prove to be defective in materials and workmanship, provided the appliance has been used under normal operating conditions as intended by the manufacturer.

Warranty Terms:

During the first year, any components of this appliance found to be defective due to materials or workmanship will be repaired or replaced, at the manufacturer's discretion, at no charge to the original purchaser. The purchaser will be responsible for any removal or transportation costs.

Warranty Exclusions:

The warranty will not apply if damage is caused by any of the following:

- Power failure
- Damage in transit or when moving the appliance
- Improper power supply such as low voltage, defective household wiring or inadequate fuses
- Accident, alteration, misuse or abuse of the appliance such as using non-approved accessories, inadequate air circulation in the room or abnormal operating conditions (extreme temperatures)
- Use in commercial or industrial applications
- Fire, water damage, theft, war, riot, hostility or acts of God such as hurricanes, floods, etc.
- Use of force or damage caused by external influences
- Partially or completely dismantled appliances
- Excess wear and tear by the user

Obtaining Service:

When making a warranty claim, please have the original bill of purchase with purchase date available. Once confirmed that your appliance is eligible for warranty service, all repairs will be performed by a NewAir™ authorized repair facility. The purchaser will be responsible for any removal or transportation costs. Replacement parts and/or units will be new, re-manufactured or refurbished and is subject to the manufacturer's discretion. For technical support and warranty service, please email support@newairusa.com.