



polkaudio
the speaker specialists®

5601 METRO DRIVE,
BALTIMORE, MARYLAND 21215, USA,
800-377-7655, FAX: 410-764-5266
www.polkaudio.com



RCi SERIES

RC60i

RC80i

RC55i

RC65i

RC85i

**Owner's
Manual**

polkaudio
the speaker specialists®

**High
Performance
In-Wall
Speakers**

PLACEMENT OPTIONS

Polk Audio RC*i* Series In-Wall Loudspeakers give you nearly endless placement options. But remember that placement choice for your in-wall speakers bears careful consideration, as installation requires that you cut a hole in your wall!

Fill a room with sound by installing in-wall speakers in nearly any wall or ceiling location [figure 1]. Polk RC*i* Series In-Wall Loudspeakers have a wide dispersion pattern and aimable tweeters that allow you to focus their sound.

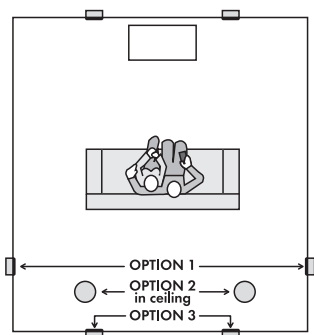

FIGURE 1
RC Series audio and A/V placement options, in wall or ceiling.

Opciones de ubicación al ras de la pared o del cielorraso para equipo audiovisual y de audio de la Serie RC.

Recommended measurements for HT front stage placement.

Platzierungsmöglichkeiten für RC-Systeme in Wand oder Zimmerdecke (Audio und kombiniertes Audio/Video)

ADJUSTING THE TWEETER

Aiming the tweeter toward your listening position improves imaging and detail. When using RC*i* Series In-Wall Loudspeakers as front/main home theater speakers [figure 2], aim the tweeter toward your listening position. For rear/surround speakers installed in walls or ceilings [figure 3], aim the tweeter toward the nearest reflecting surface (an adjacent wall or ceiling) for a more diffuse sound field (if you so desire; for more direct sound, aim the tweeters at your listening position).

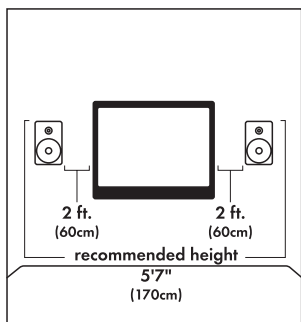

FIGURE 2
Recommended measurements for HT front stage placement.

Medidas recomendadas para la ubicación en el escenario del cine en casa.

Mesures recommandées pour l'installation des haut-parleurs avant.

Empfohlene Abmessungen für die Platzierung in Heimtheatern (Frontbeschallung).

RC55*i*, RC65*i*, RC85*i* models: Holding the edges of the tweeter carefully between the thumbs and forefingers of both hands, rock the tweeter slightly to aim it [figure 4]. RC60*i*, RC80*i* models: Grasping the round tweeter with the tips of the fingers of one hand, pivot the tweeter toward the direction you desire [figure 5]. Do not "turn" the tweeter like a door knob.

Note: RC*i* Series In-Wall Loudspeakers are not magnetically shielded and should not be placed closer than 1' (30cm) from a television or video monitor. If you experience discoloration or distortion, immediately move the speakers away from your TV.

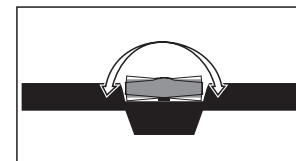

FIGURE 4
RC55*i*, RC65*i*, RC85*i* models: Holding the edges of the oblong tweeter carefully between the thumbs and forefingers of both hands, rock the tweeter slightly to aim it.

Modelos RC55*i*, RC65*i*, RC85*i*: Sujete cuidadosamente los bordes del tweeter oblongo entre sus pulgares e índices y, con un movimiento de vaivén, oriente cuidadosamente el tweeter.

RC55*i*, RC65*i* et RC85*i* : Pour orienter le tweeter, tenez son rebord avec le pouce et l'index des deux mains et basculez-le délicatement.

Modelle RC55*i*, RC65*i*, RC85*i*: Halten Sie die Kanten der rechteckigen Hochtonlautsprecher vorsichtig zwischen Daumen und Zeigefinger. Rücken Sie den Lautsprecher leicht hin und her, um ihn entsprechend auszurichten.

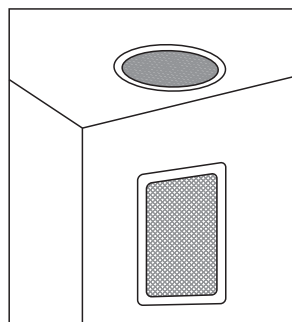

FIGURE 3
Examples of in-wall and in-ceiling placement. When used as rear/surrounds, aim tweeter toward the nearest reflecting surface (an adjacent wall or ceiling) for a more diffuse sound field.

Ejemplos de ubicación al ras de la pared o del cielorraso. Cuando se use como altavoz posterior o surround, oriente el tweeter hacia la superficie reflectora más cercana (pared o cielorraso adyacente) para producir un campo de sonido más difuso.

Exemples d'installations au mur et au plafond. Pour usage arrière-ambiphonique, dirigez les tweeters vers la surface réfléchissante la plus proche (mur ou plafond) si vous désirez une image sonore plus diffuse.

Beispiele zur Platzierung in Wand und Zimmerdecke. Bei Verwendung als Hintergrund-/Surround-System sollten die Hochtonlautsprecher zur besseren Zerstreuung des Schallfelds in Richtung der nächstliegenden reflektierenden Flächen positioniert werden (Wand oder Zimmerdecke).

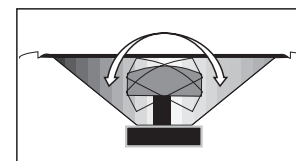

FIGURE 5
RC60*i*, RC80*i* models: Grasping the round tweeter with the tips of the fingers of one hand, pivot the tweeter in the direction you desire. Do not turn tweeter like a door knob.

Modelos RC60*i*, RC80*i*: Sujete el tweeter redondo con las puntas de los dedos de una mano y luego oriéntelo en la dirección deseada. No haga girar el tweeter como si fuera el pomo de una puerta.

RC60*i* et RC80*i* : Pour orienter le tweeter, tenez-le du bout des doigts et faites-le pivoter dans la direction désirée. Ne le tournez jamais comme une poignée de porte.

Modelle RC60*i*, RC80*i*: Halten Sie den runden Hochtonlautsprecher mit den Fingerspitzen einer Hand, während Sie ihn in die gewünschte Richtung drehen. Der Hochtonlautsprecher darf nicht wie ein Türknauf gedreht werden.

PAINTING YOUR RCi SERIES IN-WALL LOUDSPEAKERS

You will need:

- Paint of your choice (to make the job easier, we recommend spray painting the grille)
- A paperclip or corkscrew (for removing the paintable grille, corkscrew can also be used to open the wine when you relax with your newly painted RCi speakers))
- Masking tape
- Paint mask (to cover unpaintable parts, *supplied!*)

PREPARING TO PAINT:

1. Separate the parts of the speaker. If the speaker is not yet installed, the grille can be removed simply by pushing the clamp screws forward to push the grille off the speaker from the inside. If the speaker is already in the wall, carefully hook the grille with a bent paper clip and pull it gently away from the frame [figure 6].
2. When painting the frame of the speaker, use the supplied paint masks to carefully mask off the front of the speakers to protect the drivers and baffles while painting. You can do this while the speaker is already installed in the wall (if, for instance, you're repainting the room). If you do not have the paint masks, carefully mask the speaker components using paper and masking tape.

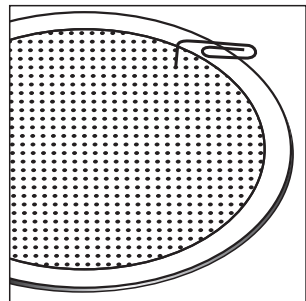

FIGURE 6
 Use a paperclip to remove grille.
 Use un sujetapapeles para quitar la rejilla.
 Utilisez un trombone pour retirer la grille.
 Entfernen Sie den Gitteraufsatz mit einer Büroklammer.

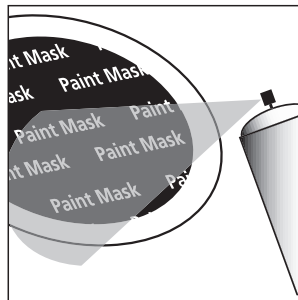

FIGURE 7
 Mask the drivers and baffles, then spray paint in thin coats.
 Enmascare los excitadores y los baffles, luego aplique manos delgadas de pintura aerosol.
 Masquez les haut-parleurs et les écrans acoustiques puis vaporisez la peinture en couches minces
 Decken Sie die Treiber und Resonanzwände ab. Spritzen Sie dann den Lack in dünnen Schichten auf.

PAINTING THE FRAME:

1. Apply paint to exposed (unmasked parts). Use two or more thin coats. Spray painting is recommended [figure 7].
2. When the paint is completely dry, remove the masking material.

PAINTING THE GRILLE:

1. The grille of the RCi Series speaker features an even, protective powder coating. This powder coating is an ideal primer.
2. Grilles must be spray painted. Do not use a brush and paint. Thick, brushed paint may clog the grille holes.
3. RC55i, RC65i, RC85i models: Before spray painting the grille, carefully remove the grille's fabric scrim by peeling it away from the inside of the grille [figure 8]. Place this on a clean, flat surface where it will not get wrinkled.

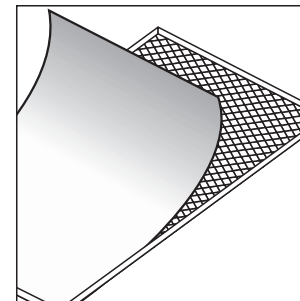

FIGURE 8
 Peel away fabric grille scrim before painting grille.
 Retire la gasa difusora de la rejilla antes de pintar la rejilla.
 Avant de peindre la grille, détachez et enlevez le tissu.
 Ziehen Sie den Stofffilter vom Schutzgitter, bevor Sie das Schutzgitter streichen.

4. After removing the grille by carefully hooking it with a bent paper clip and pulling it gently away from the frame, spray on two thin coats of finish color. If you're using a compressor and spray gun, use the finest, most diffuse setting. Be careful not to fill the holes in the grille with paint [figure 9].
5. When the paint is completely dry, carefully reinstall the grille by fitting it into its recess so that it is just resting on the frame. Starting with one corner, go around the speaker and push the grille into the grille notch a little bit at a time. Be gentle; the grille may be easily bent out of shape by rough handling. You will feel a positive "snap" when it is fully in place.
6. RC55i, RC65i, RC85i models: When the grille is dry, carefully press the fabric scrim back into place on the inside of the grille. The special fabric scrim hides the speaker's drivers from view, and will not interfere with the sound.

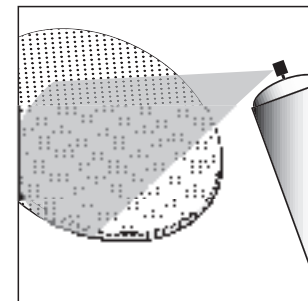

FIGURE 9
 Paint the grille. Use thin coats of spray paint. Do not block grille holes with paint.
 Pinte la rejilla. Aplique manos delgadas de pintura aerosol. No bloquee con pintura los agujeros de la rejilla.
 Peinturez la grille. Appliquez des couches minces de peinture aerosol. N'obstruez pas les trous de la grille de peinture.
 Streichen Sie den Gitteraufsatz. Verwenden Sie dazu dünne Spritzlackschichten. Die Öffnungen des Gitteraufsatzes dürfen nicht mit Farbe bzw. Lack blockiert werden.

INSTALLATION

Out of the box and into the wall, that's how easy it is to install Polk RCi Series In-Wall Loudspeakers.

If you intend to do the installation yourself we recommend that you possess some skill in the proper use of hand and power tools. You should have a thorough understanding of local building and fire codes and a familiarity with the area behind the wall or ceiling into which you plan to install your speakers. Install speaker wires before installing speakers. Wire meeting appropriate building and fire codes must be used. Use at least 18 gauge wire or heavier for the utmost in sound quality. Wiring is best performed by an experienced professional. If you are in doubt that you possess the necessary skills or tools, consult your Polk Audio dealer, or a professional installer.

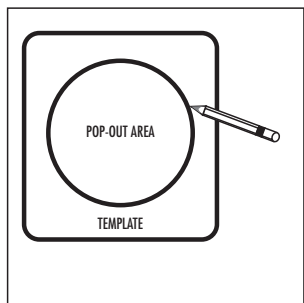

FIGURE 10a
Round Template: Trace within the pop-out area.
Plantilla redonda: Marque dentro del área que se va a desechar.
Gabarit rond: Tracez à l'intérieur du gabarit.
Runde Vorlage: Umranden Sie den inneren, gestanzten Teil der Vorlage.

YOU WILL NEED:

- Pencil for marking the location of installation
- Keyhole saw, utility knife or material-appropriate incising implement for cutting drywall or other wall material
- Level
- Screwdriver, preferably powered, with Phillips head bit
- Power drill with appropriate bit (optional, for starting wall cut)

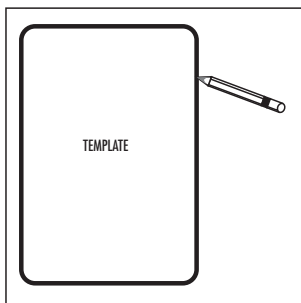

FIGURE 10b
Rectangular Template: Trace around the template.
Plantilla rectangular: Marque alrededor de la plantilla.
Gabarit rectangulaire: Tracez autour du gabarit.
Rechteckige Vorlage: Umranden Sie den äußeren Rand der Vorlage mit einem

FOLLOW THESE EASY STEPS:

- Make sure the material into which you plan to mount the speakers (plaster, drywall, paneling, stone, etc.) can support the weight of the speakers (see specification page for the weight of your model).
- Make sure the locations you select do not conceal studs, electrical wiring or plumbing. Prior to installation, hold the speaker in your chosen location to make sure it safely clears obstacles such as studs, corners, beams, lighting fixtures and door/window frames. Your cutout must be at least 1" (25mm) from adjoining walls or ceiling, internal studs or plumbing.
- Using the template, trace the installation location with a pencil. You can do this by holding the template in your preferred location and tracing around it (rectangle) or within the template pop-out area (round). Use a level to make certain the template is straight and plumb. This is the exact cutout size [figures 10a & 10b].

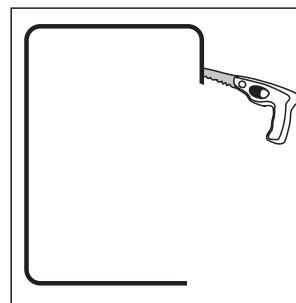

FIGURE 11
Cut the hole with the appropriate tool.
Haga el corte con la herramienta apropiada.
Taillez l'ouverture avec l'outil approprié
Schneiden Sie die Öffnung mit dem entsprechenden Werkzeug aus.

- Carefully cut the hole with the appropriate cutting tool for your wall or ceiling material. Start the hole by drilling a hole on the inside of the tracing (with the drill bit touching the line). Use this hole to insert the saw or knife and begin cutting [figure 11].
- Once you have cut the hole, fish your previously positioned wiring out of the hole and connect the speaker. Follow the hookup directions included with your receiver. Strip ½ inch (12 mm) of insulation from each of the two conductors of the wire to expose the bare metal and twist each of the conductors into a single unfrayed strand (so you have two unfrayed strands). Note that one of the terminals on the rear of each speaker is red (+) and the other is black (-). Make certain that you connect the wire from the red terminal (+) of your amplifier or receiver to the red terminal (+) on your speaker and the wire from the black terminal (-) of your amplifier or receiver to the black terminal (-) on your speaker. Most wire has some indicator (such as color-coding, ribbing or writing) on one of the two conductors to help you maintain consistency [figure 12].

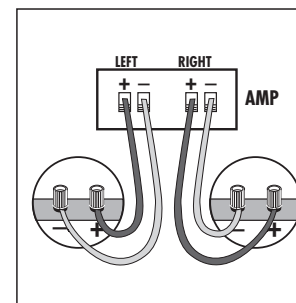

FIGURE 12
Hook up the speaker wires.
Conecte los cables de los altavoces.
Branchez les fils de haut-parleur.
Schließen Sie die Lautsprecherkabel an.

- To install the speaker, first carefully remove the grille using a straightened paperclip or other pointed metal tool. Insert the point into one of the grille perforations near a corner and lift the grille free. Never use a knife or screwdriver to pry between the grille and the speaker frame. This will damage your speaker.
- Loosen the rotating wall clamps by unscrewing them. Make sure that the rotating wall clamps are flipped inwards so that your speaker fits into your cutout without nicking your wall. Then place the speaker carefully into the cutout [figure 13]. If you have a level, use it to help you correctly align the speaker. Tighten the wall clamp screws with a screwdriver. This will rotate the wall clamps and secure the speaker to the wall. **Hint**—on the RC55*i*, RC65*i* and RC85*i* models, tighten the center screws before tightening the corners for the most flush fit to your wall. *Do not over-tighten the wall clamp screws* [figure 14].
- Carefully reinstall the grille by fitting it into its recess so that it is just resting on the frame. Starting with one corner, go around the speaker and push the grille into the grille notch a little bit at a time. Be gentle; the grille may be easily bent out of shape by rough handling. You will feel a positive “snap” when it is fully in place. (Where’s the corkscrew?)

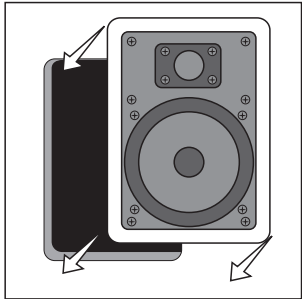

FIGURE 13

Place the speaker carefully into the cutout.

Coloque cuidadosamente el altavoz en el agujero.

Placez délicatement le haut-parleur dans l'ouverture.

Platzieren Sie die Lautsprecher vorsichtig in der ausgeschnittenen Öffnung.

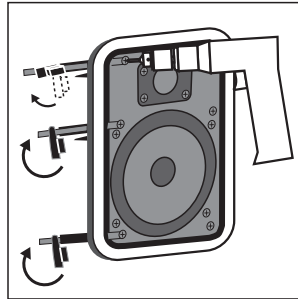

FIGURE 14

Tighten retaining wall clamps to engage wall. Use a #2 Phillips head screwdriver or a powered screwdriver.

Apriete las presas de retención de la pared para enganchar el altavoz a la pared. Use un destornillador Phillips No. 2 o un destornillador eléctrico.

Reserrez les attaches murales pour fixer solidement l'unité au mur. Utilisez un tournevis ou une perceuse à tête Phillips no 2.

Ziehen Sie die Wandklemmen fest, um das System an der Wand zu befestigen. Verwenden Sie dazu einen Kreuzschlitzschraubendreher (Nr. 2) oder einen Schraubendreher mit Motorantrieb.

SAFETY FIRST

When installing your RC*i* Series In-Wall Loudspeakers, be aware of the weight of your particular model (see specification page for the weight of your model) and the sturdiness of the material into which you are installing the speaker. Also be aware of any concealed studs, electrical wiring or plumbing in the wall or ceiling into which you are installing the speakers. If you are not sure of a safe way to install these speakers, consult a professional installer, your authorized Polk Audio dealer, or a building contractor.

If you plan to install your RC*i* Series speakers where water will directly contact them, it is advisable to use a silicone sealant or caulk between the frame of the speaker and the wall surface. This seal should prevent water from getting behind the loudspeaker and possibly damaging the wall surface. Do not position the speaker where water can pool on the surface of the woofer cone or tweeter dome, as this will greatly decrease the speaker's useful life (and everything will sound—*glub! glub!*—like it's coming from under water!).



SPECIFICATIONS

	RC55i	RC65i	RC85i
Frequency Response	67Hz-20Khz	32Hz-20Khz	30Hz-20Khz
Recommended Power	20-100wrms	20-100wrms	20-100wrms
Impedance	Compatible with 8 Ohm amplifiers	Compatible with 8 Ohm amplifiers	Compatible with 8 Ohm amplifiers
Efficiency (dB 1w/1m)	89db	89db	90db
Drive Unit Complement			
Mid-Bass	1-5/8" (13.3cm) mineral filled polypropylene cone, rubber suspension	1-6 1/2" (16.5cm) mineral filled polypropylene cone, rubber suspension	1-8" (20cm) mineral filled polypropylene cone, rubber suspension
Tweeter	3/4" (1.9cm) soft dome in swivel mount	3/4" (1.9cm) soft dome in swivel mount	1" (2.5cm) soft dome in swivel mount
Cutout Dimensions	6 3/16" x 9 9/16" (15.7cm x 24.4cm) 15.72cm x 24.45cm	7 3/16" x 10 3/4" (18.6cm x 27.3cm) 18.57cm x 27.31cm	8 3/16" x 12 3/4" (22.1cm x 32.4cm) 22.07cm x 32.39cm
Depth with 1/2" drywall	2 3/16" (5.56cm)	2 7/16" (6.19cm)	2 7/8" (7.30cm)
Shipping Weight Pair	7 1/2 LBS- 3.4 Kg	8 LBS- 3.63 Kg	11 1/2 LBS- 5.22 Kg

	RC60i	RC80i
Frequency Response	40Hz-20Khz	35Hz-20Khz
Recommended Power	20-100wrms	20-100wrms
Impedance	Compatible with 8 Ohm amplifiers	Compatible with 8 Ohm amplifiers
Efficiency (dB 1w/1m)	89db	90db
Drive Unit Complement		
Mid-Bass	1-6 1/2" (16.5cm) mineral filled polypropylene cone, rubber suspension	1-8" (20cm) mineral filled polypropylene cone, rubber suspension
Tweeter	3/4" (1.9cm) soft dome in ball and socket	1" (25mm) soft dome in ball and socket
Cutout Dimensions	7 7/16" (19.21cm) diameter	9 3/8" (23.81cm) diameter
Depth with 1/2" drywall	2 3/8" (6.03cm)	3 1/4" (8.26cm)
Shipping Weight Pair	5 1/2 LBS- 2.5 Kg	9 1/2 LBS- 4.31 Kg

POLK AUDIO LIMITED WARRANTY

Polk Audio, Inc. warrants to the original purchaser only that this Polk Audio Loudspeaker Product (the "Product") will be free from defects in materials and workmanship for a period of five (5) years from the date of original retail purchase from a Polk Audio Authorized Dealer. However, this Warranty will automatically terminate prior to the expiration of the five (5) years if the original retail purchaser sells or otherwise transfers the Product to any other party. The original retail purchaser shall hereinafter be referred to as "you." To allow Polk Audio to offer the best possible warranty service, please fill out the Product Registration Card(s) and send it to the Factory, at the address provided on the Product Cards(s) within ten (10) days of the date of purchase.

Defective Products must be shipped, together with proof of purchase, prepaid insured to the Polk Audio Authorized Dealer from whom you purchased the Product, or to the Factory at 2550 Britannia Boulevard, Suite D, San Diego, California 92154. Products must be shipped in the original shipping container or its equivalent; in any case the risk of loss or damage in transit is to be borne by you. If upon examination at the Factory or Polk Audio Authorized Dealer it is determined that the unit was defective in materials or workmanship at any time during this Warranty period, Polk Audio or the Polk Audio Authorized Dealer will, at its option, repair or replace this Product at no additional charge, except as set forth below. All replaced parts and Products become the property of Polk Audio. Products replaced or repaired under this warranty will be returned to you, within a reasonable time, freight prepaid.

This warranty does not include service or parts to repair damage caused by accident, disaster, misuse, abuse, negligence,

inadequate packing or shipping procedures, commercial use, voltage inputs in excess of the rated maximum of the unit, cosmetic appearance of cabinetry not directly attributable to defect in materials or workmanship, or service, repair, or modification of the Product which has not been authorized or approved by Polk Audio. This warranty shall terminate if the Serial number on the Product has been removed, tampered with or defaced.

This warranty is in lieu of all other expressed Warranties. If this Product is defective in materials or workmanship as warranted above, your sole remedy shall be repair or replacement as provided above. In no event will Polk Audio, Inc. be liable to you for any incidental or consequential damages arising out of the use or inability to use the Product, even if Polk Audio, Inc. or a Polk Audio Authorized Dealer has been advised of the possibility of such damages, or for any claim by any other party. Some states do not allow the exclusion or limitation of consequential damages, so the above limitation and exclusion may not apply to you.

All implied warranties on this Product are limited to the duration of this expressed Warranty. Some states do not allow limitation on how long an implied Warranty lasts, so the above limitations may not apply to you. This Warranty gives you specific legal rights, and you also may have other rights which vary from state to state.

This Warranty applies only to Products purchased in the United States of America, its possessions, and U.S. and NATO armed forces exchanges and audio clubs. The Warranty terms and conditions applicable to Products purchased in other countries are available from the Polk Audio Authorized Distributors in such countries.

"Polk Audio," "Polk," "The Speaker Specialists," "Power Port" and "Dynamic Balance" are trademarks of Britannia Investment Corporation used under license by Polk Audio Incorporated.

Dolby, Pro Logic, Dolby Digital and AC-3 are trademarks of Dolby Laboratories Licensing Corp.