

# OPERATOR'S MANUAL

# CRAFTSMAN®

## 9 in. BAND SAW

Model No.  
315.214770

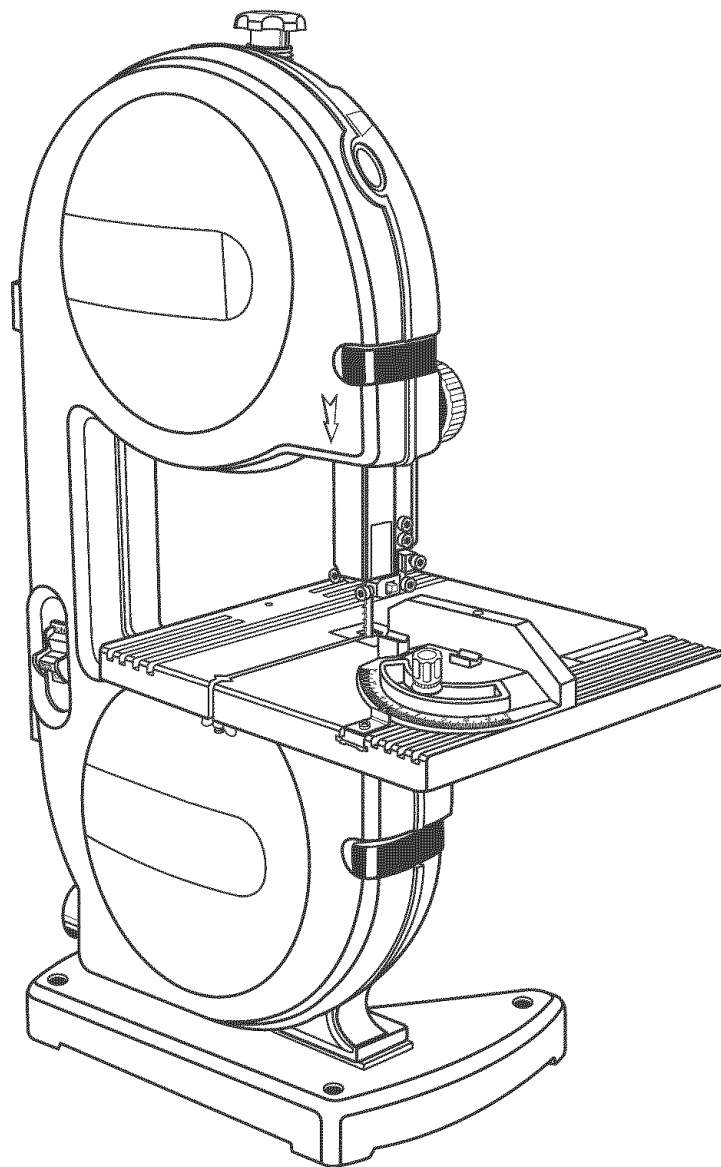

**WARNING:** To reduce the risk of injury, the user must read and understand the operator's manual before using this product.

Customer Help Line: 1-800-932-3188

Sears, Roebuck and Co., 3333 Beverly Rd., Hoffman Estates, IL 60179 USA  
Visit the Craftsman web page: [www.sears.com/craftsman](http://www.sears.com/craftsman)

983000-577  
8-04

**Save this manual for future reference**



# TABLE OF CONTENTS

■ Warranty .....	2
■ Introduction .....	2
■ General Safety Rules .....	3-4
■ Symbols.....	5-6
■ Electrical .....	7
■ Glossary of Terms.....	8
■ Features.....	9-10
■ Tools Needed.....	11
■ Loose Parts List.....	11
■ Assembly .....	12-18
■ Operation.....	18-20
■ Maintenance .....	21-22
■ Troubleshooting .....	23
■ Exploded View and Parts List.....	24
■ Parts Ordering/Service .....	Back Page

## WARRANTY

### FULL ONE YEAR WARRANTY ON CRAFTSMAN TOOL

If this **CRAFTSMAN** tool fails to give complete satisfaction within one year from the date of purchase, **RETURN IT TO THE NEAREST SEARS STORE OR SEARS SERVICE CENTER IN THE UNITED STATES**, and Sears will repair it, free of charge.

If this **CRAFTSMAN** tool is used for commercial or rental purposes, this warranty applies for only 90 days from the date of purchase.

This warranty gives you specific legal rights, and you may also have other rights which vary from state to state.

**Sears, Roebuck and Co., Dept. 817WA, Hoffman Estates, IL 60179**

## INTRODUCTION

This tool has many features for making its use more pleasant and enjoyable. Safety, performance, and dependability have been given top priority in the design of this product making it easy to maintain and operate.

# GENERAL SAFETY RULES

**⚠ WARNING: Read and understand all instructions.** Failure to follow all instructions listed below, may result in electric shock, fire and/or serious personal injury.

## READ ALL INSTRUCTIONS

- **KNOW YOUR POWER TOOL.** Read the operator's manual carefully. Learn the applications and limitations as well as specific potential hazards related to this tool.
- **GUARD AGAINST ELECTRICAL SHOCK** by preventing body contact with grounded surfaces. For example: pipes, radiators, ranges, refrigerator enclosures.
- **KEEP GUARDS IN PLACE** and in working order. Never operate the tool with any guard or cover removed. Make sure all guards are operating properly before each use.
- **REMOVE ADJUSTING KEYS AND WRENCHES.** Form habit of checking to see keys and adjusting wrenches are removed from tool before turning it on.
- **KEEP THE WORK AREA CLEAN.** Cluttered work areas and work benches invite accidents.
- **DO NOT USE IN DANGEROUS ENVIRONMENTS.** Do not use power tools near gasoline or other flammable liquids, in damp or wet locations or expose them to rain. Keep work area well lighted.
- **KEEP CHILDREN AND VISITORS AWAY.** All visitors should wear safety glasses and be kept a safe distance from work area.
- **MAKE WORKSHOP CHILDPROOF** with padlocks, master switches, or by removing starter keys.
- **DO NOT FORCE THE TOOL.** It will do the job better and safer at the rate for which it was designed.
- **USE THE RIGHT TOOL.** Do not force the tool or attachment to do a job for which it was not designed.
- **USE THE PROPER EXTENSION CORD.** Make sure your extension cord is in good condition. When using an extension cord, be sure to use one heavy enough to carry the current your product will draw. An undersized cord will cause a drop in line voltage resulting in loss of power and overheating. A wire gage size (A.W.G.) of at least **16** is recommended for an extension cord 25 feet or less in length. If in doubt, use the next heavier gage. The smaller the gage number, the heavier the cord.
- **WEAR PROPER APPAREL.** Do not wear loose clothing, neckties, or jewelry that can get caught in the tool's moving parts and cause personal injury. Nonslip footwear is recommended when working outdoors. Wear protective hair covering to contain long hair.
- **ALWAYS WEAR SAFETY GLASSES WITH SIDE SHIELDS.** Everyday eyeglasses have only impact-resistant lenses; they are **NOT** safety glasses.
- **SECURE WORK.** Use clamps or a vise to hold work when practical. It's safer than using your hand and it frees both hands to operate tool.
- **DO NOT OVERREACH.** Keep proper footing and balance at all times.
- **MAINTAIN TOOLS WITH CARE.** Keep tools sharp and clean for best and safest performance. Follow instructions for lubricating and changing accessories.
- **DISCONNECT ALL TOOLS.** When not in use, before servicing, or when changing attachments, blades, bits, cutters, etc., all tools should be disconnected from power source.
- **REDUCE THE RISK OF UNINTENTIONAL STARTING.** Be sure switch is off when plugging in.
- **USE RECOMMENDED ACCESSORIES.** Consult the operator's manual for recommended accessories. The use of improper accessories may cause risk of injury.
- **NEVER STAND ON TOOL.** Serious injury could occur if the tool is tipped or if the blade is unintentionally contacted.
- **CHECK DAMAGED PARTS.** Before further use of the tool, a guard or other part that is damaged should be carefully checked to determine that it will operate properly and perform its intended function. Check for alignment of moving parts, binding of moving parts, breakage of parts, mounting and any other conditions that may affect its operation. A guard or other part that is damaged must be properly repaired or replaced by an authorized service center to avoid risk of personal injury.
- **DIRECTION OF FEED.** Feed work into a blade or cutter against the direction or rotation of the blade or cutter only.
- **NEVER LEAVE TOOL RUNNING UNATTENDED. TURN POWER OFF.** Do not leave tool until it comes to a complete stop.
- **DO NOT ABUSE CORD.** Never carry tool by the cord or yank it to disconnect from receptacle. Keep cord from heat, oil, and sharp edges.
- **PROTECT YOUR LUNGS.** Wear a face or dust mask if the cutting operation is dusty.
- **PROTECT YOUR HEARING.** Wear hearing protection during extended periods of operation.
- **BLADE COASTS AFTER TURN OFF.**
- **KEEP TOOL DRY, CLEAN, AND FREE FROM OIL AND GREASE.** Always use a clean cloth when cleaning. Never use brake fluids, gasoline, petroleum-based products, or any solvents to clean tool.
- **INSPECT TOOL CORDS AND EXTENSION CORDS PERIODICALLY** and, if damaged, have repaired by a qualified service technician. Stay constantly aware of cord location and keep it well away from the rotating wheel.
- **NEVER USE IN AN EXPLOSIVE ATMOSPHERE.** Normal sparking of the motor could ignite fumes.
- **USE ONLY OUTDOOR EXTENSION CORDS** with approved ground connection that are intended for use outdoors and so marked.
- **BE SURE THE BLADE PATH IS FREE OF NAILS.** Inspect for and remove nails from lumber before cutting.

# GENERAL SAFETY RULES











- **AVOID AWKWARD OPERATIONS AND HAND POSITIONS** where a sudden slip could cause your hand to move into the blade. **ALWAYS** make sure you have good balance.
  - **ALLOW THE MOTOR TO COME UP TO FULL SPEED** before starting a cut to avoid binding or stalling.
  - **DO NOT USE TOOL IF SWITCH DOES NOT TURN IT ON AND OFF.** Have defective switches replaced by an authorized service center.
  - **REPLACEMENT PARTS.** All repairs, whether electrical or mechanical, should be made by a qualified service technician at an authorized service center.
  - **WHEN SERVICING USE ONLY IDENTICAL REPLACEMENT PARTS.** Use of any other parts may create a hazard or cause product damage.
  - **KEEP HANDS AWAY FROM CUTTING AREA.** Do not hand hold pieces so small that your fingers go under the blade guard. Do not reach underneath work or in blade cutting path with your hands and fingers for any reason.
  - **NEVER CUT MORE THAN ONE PIECE AT A TIME** or stack more than one workpiece on the saw table at a time.
  - **FIRMLY CLAMP OR BOLT** the saw to a stable, level workbench or table. The most comfortable table height is approximately waist height.
  - **DO NOT FEED THE MATERIAL TOO QUICKLY.** Do not force the workpiece against the blade.
  - **USE ONLY CORRECT BLADES.** Use the right blade size, style, and cutting speed for the material and the type of cut. Blade teeth should point down toward the table.
  - **BEFORE MAKING A CUT, BE SURE ALL ADJUSTMENTS ARE SECURE.**
  - **ALWAYS SUPPORT LARGE WORKPIECES** while cutting to minimize risk of blade pinching and kick-back. Saw may slip, walk, or slide while cutting large or heavy boards.
  - **DO NOT REMOVE JAMMED CUTOFF PIECES** until blade has stopped.
  - **NEVER START THE TOOL** when the blade is in contact with the workpiece.
  - **NEVER TOUCH BLADE** or other moving parts during use.
  - **BEFORE CHANGING THE SETUP, REMOVING COVERS, GUARDS, OR BLADES,** unplug the saw and remove the switch key.
  - **KEEP BLADES CLEAN, SHARP, AND WITH SUFFICIENT SET.** Sharp blades minimize stalling and kick-backs.
  - **ALWAYS TURN OFF SAW** before disconnecting it to avoid accidental starting when reconnecting to a power source.
  - **DO NOT OPERATE THIS TOOL WHILE UNDER THE INFLUENCE OF DRUGS, ALCOHOL OR ANY MEDICATION.**
  - **STAY ALERT AND EXERCISE CONTROL.** Watch what you are doing and use common sense. **Do not** operate tool when you are tired. **Do not rush.**
  - **MAKE SURE WORK AREA HAS AMPLE LIGHTING** to see the work and that no obstructions will interfere with safe operation **BEFORE** performing any work using the saw.
  - **SAVE THESE INSTRUCTIONS.** Refer to them frequently and use them to instruct other users. If you loan someone this tool, loan them these instructions also.
  - **MAINTAIN PROPER ADJUSTMENT OF BLADE TENSION, BLADE GUIDES, AND THRUST BEARINGS.**
  - **ADJUST UPPER GUIDE TO JUST CLEAR WORKPIECE.**
  - **HOLD WORKPIECE FIRMLY AGAINST TABLE.**
-  **WARNING:** Some dust created by power sanding, sawing, grinding, drilling, and other construction activities contains chemicals known to cause cancer, birth defects or other reproductive harm. Some examples of these chemicals are:
- lead from lead-based paints,
  - crystalline silica from bricks and cement and other masonry products, and
  - arsenic and chromium from chemically-treated lumber.
- Your risk from these exposures varies, depending on how often you do this type of work. To reduce your exposure to these chemicals, work in a well ventilated area, and work with approved safety equipment, such as those dust masks that are specially designed to filter out microscopic particles.

## ATTENTION:

-  **WARNING:** The blade guides have been preset at the factory. These settings are functional for some applications. We recommend that you check and adjust blade guide settings before first use of the saw. Refer to **“ADJUSTING THRUST BEARINGS, BLADE GUIDE SUPPORT, AND BLADE GUIDES”** procedures explained in the **ADJUSTMENTS** section of this operator’s manual.



# SYMBOLS

Some of the following symbols may be used on this tool. Please study them and learn their meaning. Proper interpretation of these symbols will allow you to operate the tool better and safer.

SYMBOL	NAME	DESIGNATION/EXPLANATION
V	Volts	Voltage
A	Amperes	Current
Hz	Hertz	Frequency (cycles per second)
W	Watt	Power
min	Minutes	Time
~	Alternating Current	Type of current
—	Direct Current	Type or a characteristic of current
$n_0$	No Load Speed	Rotational speed, at no load
	Class II Construction	Double-insulated construction
.../min	Per Minute	Revolutions, strokes, surface speed, orbits etc., per minute
	Wet Conditions Alert	Do not expose to rain or use in damp locations.
	Read The Operator's Manual	To reduce the risk of injury, user must read and understand operator's manual before using this product.
	Eye Protection	Always wear safety goggles or safety glasses with side shields and a full face shield when operating this product.
	Safety Alert	Precautions that involve your safety.
	No Hands Symbol	Failure to keep your hands away from the blade will result in serious personal injury.
	No Hands Symbol	Failure to keep your hands away from the blade will result in serious personal injury.
	No Hands Symbol	Failure to keep your hands away from the blade will result in serious personal injury.
	No Hands Symbol	Failure to keep your hands away from the blade will result in serious personal injury.
	Hot Surface	To reduce the risk of injury or damage, avoid contact with any hot surface.

# SYMBOLS

The following signal words and meanings are intended to explain the levels of risk associated with this product.

SYMBOL	SIGNAL	MEANING
	<b>DANGER:</b>	Indicates an imminently hazardous situation, which, if not avoided, will result in death or serious injury.
	<b>WARNING:</b>	Indicates a potentially hazardous situation, which, if not avoided, could result in death or serious injury.
	<b>CAUTION:</b>	Indicates a potentially hazardous situation, which, if not avoided, may result in minor or moderate injury.
	<b>CAUTION:</b>	(Without Safety Alert Symbol) Indicates a situation that may result in property damage.

## SERVICE

Servicing requires extreme care and knowledge and should be performed only by a qualified service technician. For service we suggest you return the product to your nearest **AUTHORIZED SERVICE CENTER** for repair. When servicing, use only identical replacement parts.

 **WARNING:** To avoid serious personal injury, do not attempt to use this product until you read thoroughly and understand completely the operator's manual. Save this operator's manual and review frequently for continuing safe operation and instructing others who may use this product.

## WARNING:



The operation of any power tool can result in foreign objects being thrown into your eyes, which can result in severe eye damage. Before beginning power tool operation, always wear safety goggles or safety glasses with side shields and a full face shield when needed. We recommend Wide Vision Safety Mask for use over eyeglasses or standard safety glasses with side shields. Always use eye protection which is marked to comply with ANSI Z87.1.

## SAVE THESE INSTRUCTIONS

# ELECTRICAL

## EXTENSION CORDS

Use only 3-wire extension cords that have 3-prong grounding plugs and 3-pole receptacles that accept the tool's plug. When using a power tool at a considerable distance from the power source, use an extension cord heavy enough to carry the current that the tool will draw. An undersized extension cord will cause a drop in line voltage, resulting in a loss of power and causing the motor to overheat. Use the chart provided below to determine the minimum wire size required in an extension cord. Only round jacketed cords listed by Underwriter's Laboratories (UL) should be used.

\*\*Ampere rating (on tool faceplate)

Cord Length	Wire Size (A.W.G.)					
	0-2.0	2.1-3.4	3.5-5.0	5.1-7.0	7.1-12.0	12.1-16.0
25'	16	16	16	16	14	14
50'	16	16	16	14	14	12
100'	16	16	14	12	10	—

\*\*Used on 12 gauge - 20 amp circuit.

**NOTE:** AWG = American Wire Gauge

When working with the tool outdoors, use an extension cord that is designed for outside use. This is indicated by the letters "WA" on the cord's jacket.

Before using an extension cord, inspect it for loose or exposed wires and cut or worn insulation.

**WARNING:** Keep the extension cord clear of the working area. Position the cord so that it will not get caught on lumber, tools or other obstructions while you are working with a power tool. Failure to do so can result in serious personal injury.

**WARNING:** Check extension cords before each use. If damaged replace immediately. Never use tool with a damaged cord since touching the damaged area could cause electrical shock resulting in serious injury.

## ELECTRICAL CONNECTION

This tool is powered by a precision built electric motor. It should be connected to a **power supply that is 120 volts, 60 Hz, AC only (normal household current)**. Do not operate this tool on direct current (DC). A substantial voltage drop will cause a loss of power and the motor will overheat. If the saw does not operate when plugged into an outlet, double check the power supply.

## SPEED AND WIRING

The no-load speed of this tool is approximately 3,000 sfpm. This speed is not constant and decreases under a load or with lower voltage. For voltage, the wiring in a shop is as important as the motor's horsepower rating. A line intended only for lights cannot properly carry a power tool motor. Wire that is heavy enough for a short distance will be too light for a greater distance. A line that can support one power tool may not be able to support two or three tools.

## GROUNDING INSTRUCTIONS

In the event of a malfunction or breakdown, grounding provides a path of least resistance for electric current to reduce the risk of electric shock. This tool is equipped with an electric cord having an equipment-grounding conductor and a grounding plug. The plug must be plugged into a matching outlet that is properly installed and grounded in accordance with all local codes and ordinances.

Do not modify the plug provided. If it will not fit the outlet, have the proper outlet installed by a qualified electrician. Improper connection of the equipment-grounding conductor can result in a risk of electric shock. The conductor with insulation having an outer surface that is green with or without yellow stripes is the equipment-grounding conductor. If repair or replacement of the electric cord or plug is necessary, do not connect the equipment-grounding conductor to a live terminal.

Check with a qualified electrician or service personnel if the grounding instructions are not completely understood, or if in doubt as to whether the tool is properly grounded. Repair or replace a damaged or worn cord immediately.

This tool is intended for use on a circuit that has an outlet like the one shown in figure 1. It also has a grounding pin like the one shown.

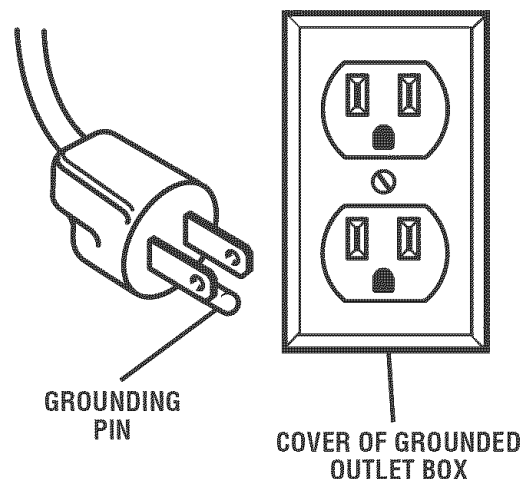

Fig. 1

# GLOSSARY OF TERMS

## **Anti-Kickback Pawls (radial arm and table saws)**

A device which, when properly installed and maintained, is designed to stop the workpiece from being kicked back toward the front of the saw during a ripping operation.

## **Arbor**

The shaft on which a blade or cutting tool is mounted.

## **Bevel Cut**

A cutting operation made with the blade at any angle other than 90° to the table surface.

## **Chamfer**

A cut removing a wedge from a block so the end (or part of the end) is angled rather than at 90°.

## **Compound Cut**

A cross cut made with both a miter and a bevel angle.

## **Crosscut**

A cutting or shaping operation made across the grain or the width of the workpiece.

## **Cutter Head (planers and jointers)**

A rotating piece of adjustable blades. The cutter head removes material from the workpiece.

## **Dado Cut**

A non-through cut which produces a square-sided notch or trough in the workpiece (requires a special blade).

## **Featherboard**

A device used to help control the workpiece by guiding it securely against the table or fence during any ripping operation.

## **FPM or SPM**

Feet per minute (or strokes per minute), used in reference to blade movement.

## **Freehand**

Performing a cut without the workpiece being guided by a fence, miter gauge, or other aids.

## **Gum**

A sticky, sap-based residue from wood products.

## **Heel**

Alignment of the blade to the fence.

## **Kerf**

The material removed by the blade in a through cut or the slot produced by the blade in a non-through or partial cut.

## **Kickback**

A hazard that can occur when the blade binds or stalls, throwing the workpiece back toward operator.

## **Leading End**

The end of the workpiece pushed into the tool first.

## **Miter Cut**

A cutting operation made with the workpiece at any angle to the blade other than 90°.

## **Non-Through Cuts**

Any cutting operation where the blade does not extend completely through the thickness of the workpiece.

## **Push Blocks and Push Sticks**

Devices used to feed the workpiece through the saw blade during cutting operations. A push stick (not a push block) should be used for narrow ripping operations. These aids help keep the operator's hands well away from the blade.

## **Pilot Hole (drill presses)**

A small hole drilled in a workpiece that serves as a guide for drilling large holes accurately.

## **Resaw**

A cutting operation to reduce the thickness of the workpiece to make thinner pieces.

## **Resin**

A sticky, sap-based substance that has hardened.

## **Revolutions Per Minute (RPM)**

The number of turns completed by a spinning object in one minute.

## **Ripping or Rip Cut**

A cutting operation along the length of the workpiece.

## **Riving Knife/Spreader/Splitter (table saws)**

A metal piece, slightly thinner than the blade, which helps keep the kerf open and also helps to prevent kickback.

## **Saw Blade Path**

The area over, under, behind, or in front of the blade. As it applies to the workpiece, that area which will be or has been cut by the blade.

## **Set**

The distance that the tip of the saw blade tooth is bent (or set) outward from the face of the blade.

## **Snipe (planers)**

Depression made at either end of a workpiece by cutter blades when the workpiece is not properly supported.

## **Throw-Back**

The throwing back of a workpiece usually caused by the workpiece being dropped into the blade or being placed inadvertently in contact with the blade.

## **Through Sawing**

Any cutting operation where the blade extends completely through the thickness of the workpiece.

## **Workpiece or Material**

The item on which the operation is being done.

## **Worktable**

Surface where the workpiece rests while performing a cutting, drilling, planing, or sanding operation.

# FEATURES

## PRODUCT SPECIFICATIONS

Blade Width ..... 1/8 in. to 3/8 in.  
 Blade Length ..... 59-1/4 in.  
 Frame to Blade Capacity ..... 9 in.  
 Cutting Thickness Capacity ..... 3-1/8 in.  
 Table Size ..... 11-3/8 in. x 11-3/8 in.  
 Table Tilt ..... 0° - 45°

Input ..... 120 Volt, 60Hz, AC Only, 2.3 Amps  
 No Load Speed ..... 3,000 SFPM  
 Overall Dimensions ..... 19-1/2 in. x 12-1/2 in. x 28 in.  
 Net Weight ..... 37 lbs.  
 Dust Port ..... 1-3/4 in.

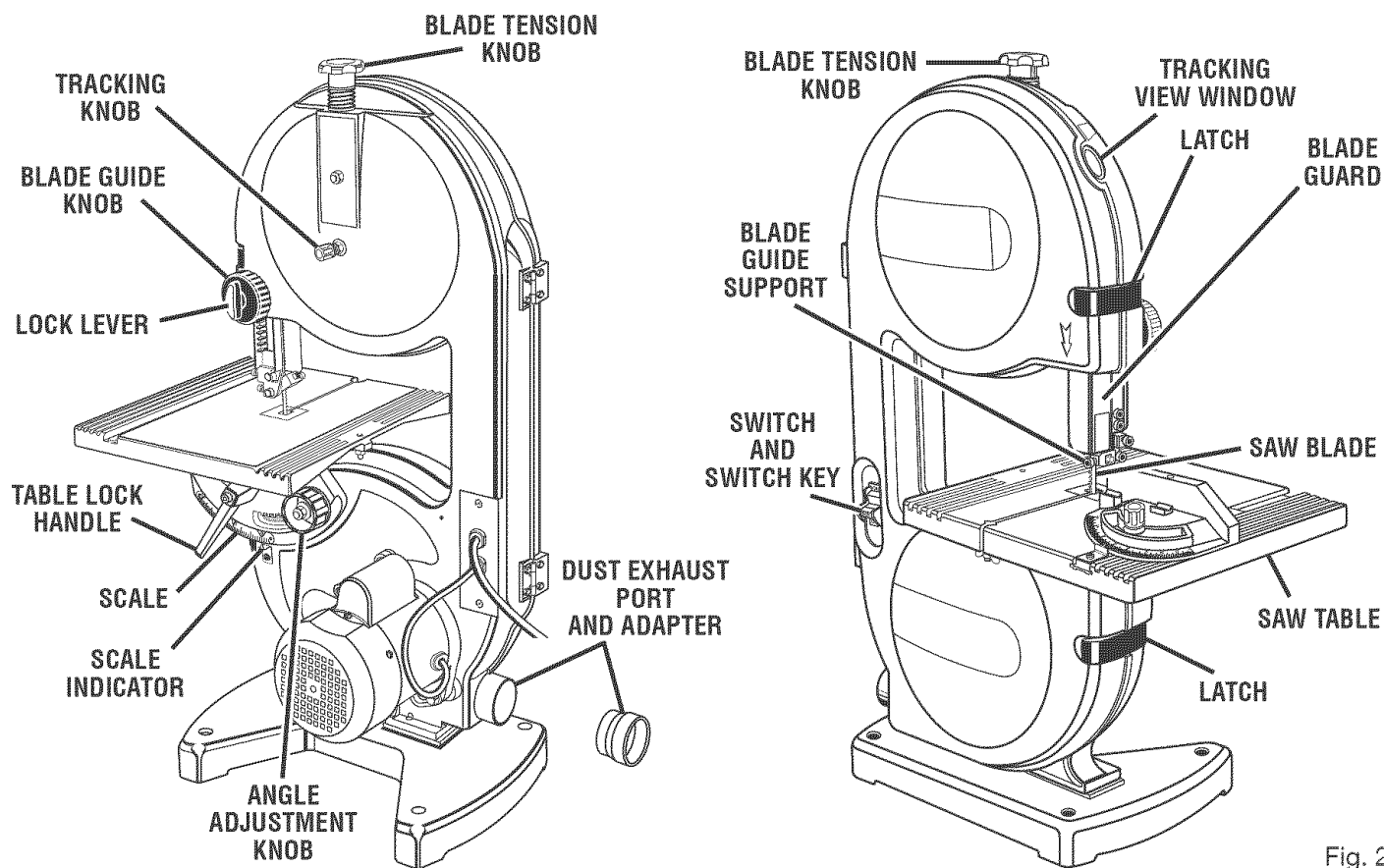

Fig. 2

# FEATURES

## KNOW YOUR BAND SAW

See Figure 2.

Before attempting to use this product, familiarize yourself with all operating features and safety rules.

### Angle Adjustment Knob

Tilts the saw table for bevel cutting.

### Blade Guard

Protects the operator from coming in contact with the blade.

### Blade Guide Support

Helps keep the blade from twisting during operation.

### Blade Guide Knob with Lock Lever

Use the blade guide knob and lock lever to adjust the blade guide assembly to keep the blade from twisting or breaking. Always lock the blade guide assembly in place before turning on the band saw.

### Blade Tension Knob

Controls blade tension when changing blades and making adjustments for various sawing applications.

### Dust Exhaust Port and Adapter

A 1-3/4 in. dust exhaust port makes dustless cutting possible by blowing the dust away from the user. Attach the adapter to the dust exhaust port when using a dust collection system or shop vac.

### Latch

Easy-open latches allow front cover to be opened for making adjustments.

### Saw Blade

The band saw comes with a standard saw blade installed. Two extra saw blades are included with the loose parts.

### Saw Table

The band saw has a square 11-3/8 in. aluminum saw table with tilt control for maximum accuracy. The throat plate, installed in the saw table at the factory, allows for blade clearance.

### Scale and Scale Indicator

The scale and scale indicator show the angle or degree the saw table is tilted for bevel cutting.

### Switch and Switch Key

Your band saw has an easy access power switch. To lock in the **OFF** position, remove the yellow switch key. Place the key in a location inaccessible to children and others not qualified to use the tool.

### Table Lock Handle

Loosening the table lock handle allows the saw table to be tilted at different angles. Tightening the table lock handle locks the saw table in place.

### Tracking Knob

Adjusts tracking to keep blade centered on the wheels.

### Tracking View Window

The tracking view window makes tracking adjustments easier to see.

## TOOLS NEEDED

The following tools (not included) are needed for checking adjustments of the saw or for installing the blade:

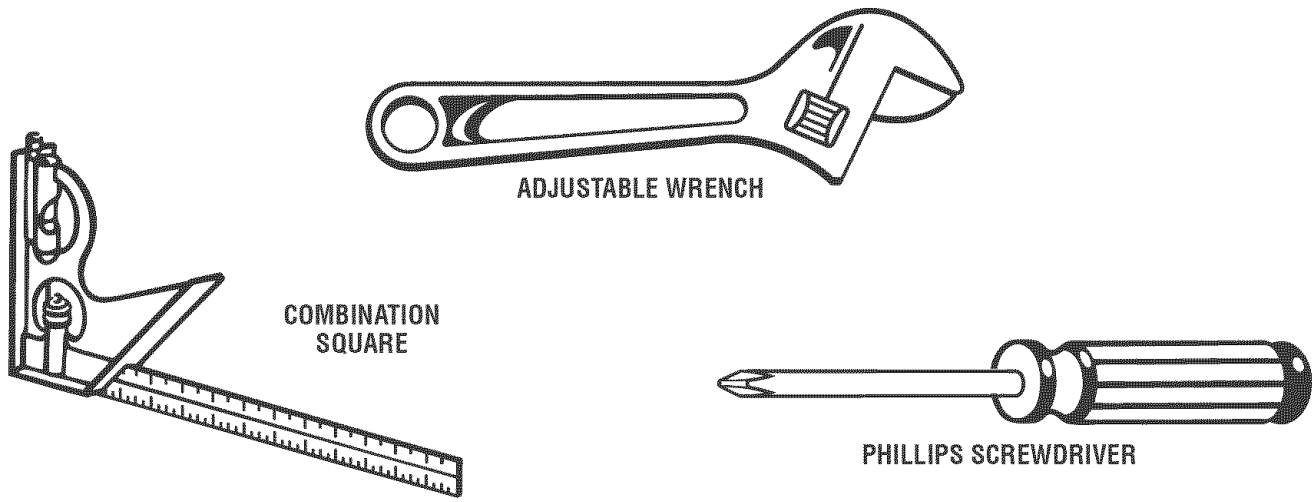

Fig. 3

## LOOSE PARTS LIST

The following items are included with the tool:

3 mm Hex Key .....	1	Table Lock Handle .....	1
4 mm Hex Key .....	1	Washer .....	1
5 mm Hex Key .....	1	Saw Blades .....	2
Miter Gauge .....	1	Operator's Manual (not shown) .....	1
Saw Table .....	1		

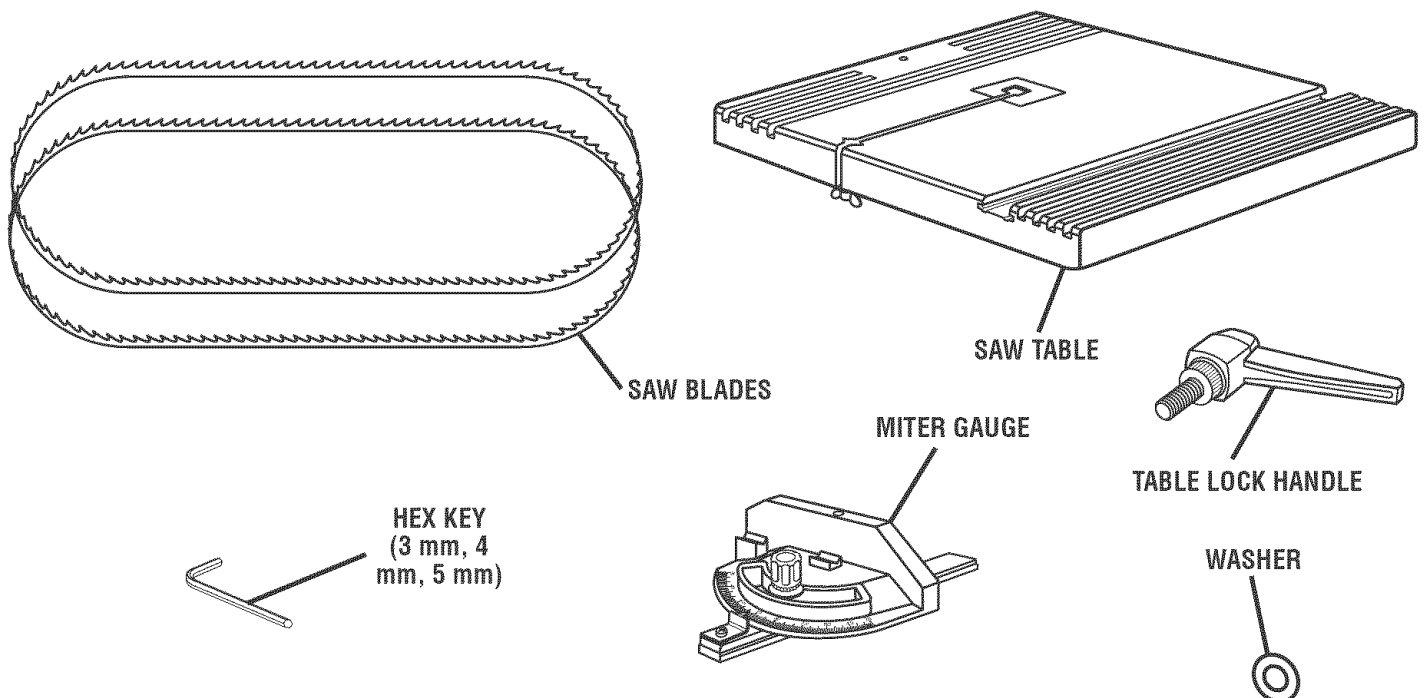

Fig. 4

# ASSEMBLY

## UNPACKING

This product requires assembly.

- Carefully lift saw from the carton and place it on a level work surface.

**NOTE:** This tool is heavy. To avoid back injury, lift with your legs, not your back, and get help when needed.

- Inspect the tool carefully to make sure no breakage or damage occurred during shipping.
- Do not discard the packing material until you have carefully inspected and satisfactorily operated the tool.
- The saw is factory set for accurate cutting. After assembling it, check for accuracy. If shipping has influenced the settings, refer to specific procedures explained in this manual.
- If any parts are damaged or missing, please call 1-800-932-3188 for assistance.

**WARNING:** If any parts are missing, do not operate this tool until the missing parts are replaced. Failure to do so could result in possible serious personal injury.

**WARNING:** Do not attempt to modify this tool or create accessories not recommended for use with this tool. Any such alteration or modification is misuse and could result in a hazardous condition leading to possible serious personal injury.

**WARNING:** Do not connect to power supply until assembly is complete. Failure to comply could result in accidental starting and possible serious personal injury.

## MOUNTING THE SAW TABLE

See Figures 5 - 6.

**WARNING:** Always make sure the band saw is securely mounted to a workbench or an approved work stand. Failure to heed this warning can result in serious personal injury.

- Remove the angle adjustment knob from the side of the saw housing.

**NOTE:** Take care when removing the nut and washer from the center of the angle adjustment knob. There is a spring in the center that is released after the nut and washer are removed.
- Remove the table aligning bolt, washer, and wing nut from the saw table.
- Standing at the front of the band saw, slide the saw table through the slot moving from the right side of the saw table to the left.

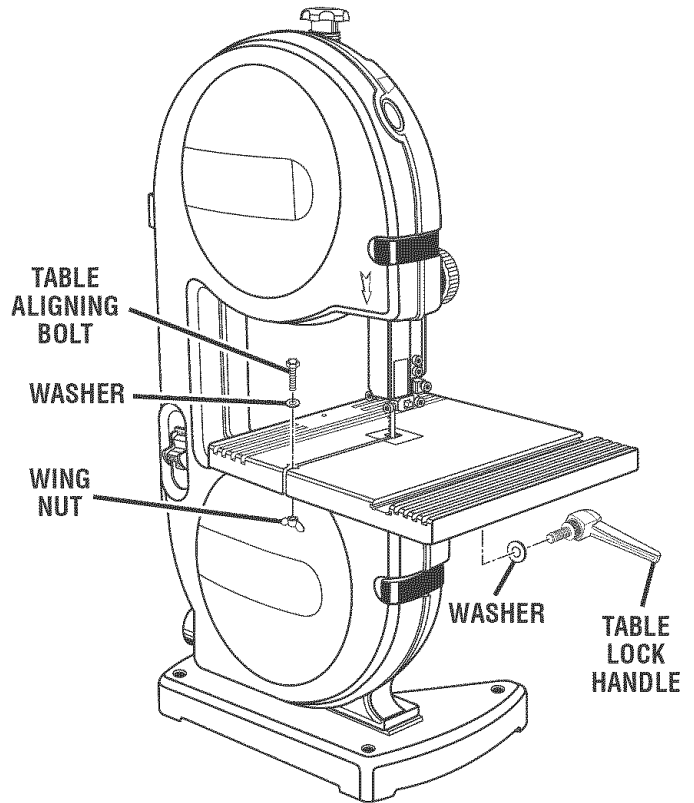

Fig. 5

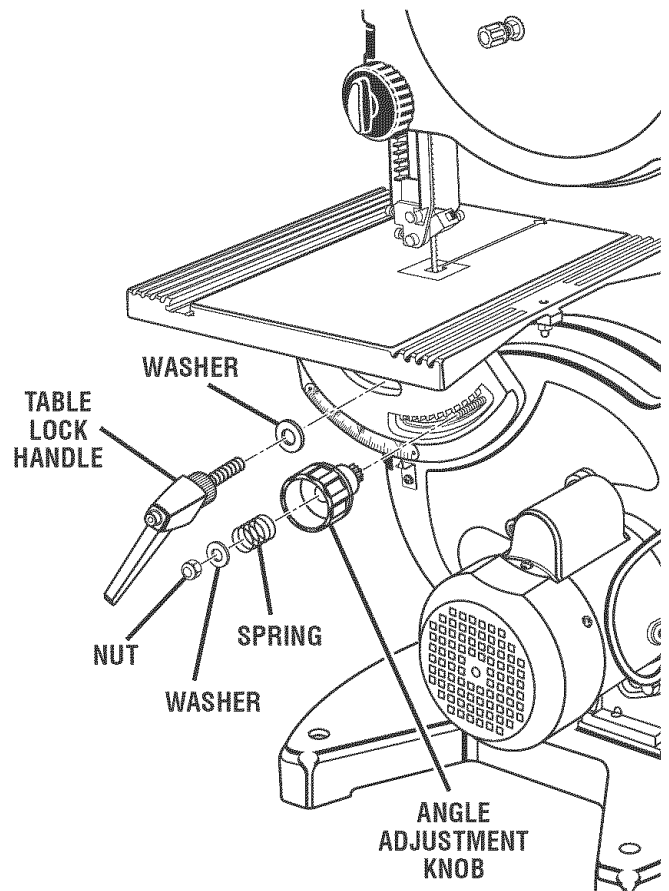

Fig. 6

# ASSEMBLY

- Insert the washer on the threaded end of the table lock handle. The table lock handle is spring loaded and is released by pulling the handle away from the saw housing. Tighten the saw table to the saw housing by ratcheting the table lock handle clockwise or by finger tightening the table lock handle.
- Reattach the angle adjustment knob using the spring, washer, and nut.
- Reattach the table aligning bolt, washer, and wing nut to the saw table.  
**NOTE:** The wing nut goes below the saw table.

## MOUNTING BAND SAW TO WORKBENCH

If the band saw is to be used in a permanent location, we recommend that you secure it to a workbench or other stable surface. When mounting the saw to a workbench, holes should be drilled through the supporting surface of the workbench.

- Each hole in the saw base should be bolted securely using bolts, lock washers, and hex nuts (not included).
- Place band saw on the workbench. Using the saw base as a pattern, locate and mark the holes where the band saw is to be mounted.
- Drill four holes through the workbench.
- Place band saw on the workbench aligning holes in the saw base with the holes drilled in the workbench.
- Insert all four bolts (not included) and tighten securely with lock washers and hex nuts (not included).

**NOTE:** All bolts should be inserted from the top. Install the lock washers and hex nuts from the underside of the bench.

Supporting surface where band saw is mounted should be examined carefully after mounting to insure that no movement during use can result. If any tipping or walking is noted, secure workbench or support surface before beginning cutting operation.

## CLAMPING BAND SAW TO WORKBENCH

See Figure 7.

If the band saw is to be used as a portable tool, it is recommended that you fasten it permanently to a mounting board that can easily be clamped to a workbench or other supporting surface. The mounting board should be of sufficient size to avoid tipping of saw while in use. Any good grade plywood or chipboard with a 3/4 in. thickness is recommended.

- Mount saw to board using holes in saw base as a template for hole pattern. Locate and mark the holes where the band saw is to be mounted.
- Follow the last three steps in the section **Mounting Band Saw to Workbench**.

If lag bolts are used, make sure they are long enough to go through holes in the saw base and material the saw is being mounted to. If machine bolts are being used, make sure bolts are long enough to go through holes in the saw base, the material being mounted to, and the lock washers and hex nuts.

**NOTE:** It may be necessary to countersink hex nuts and washers on bottom side of mounting board.

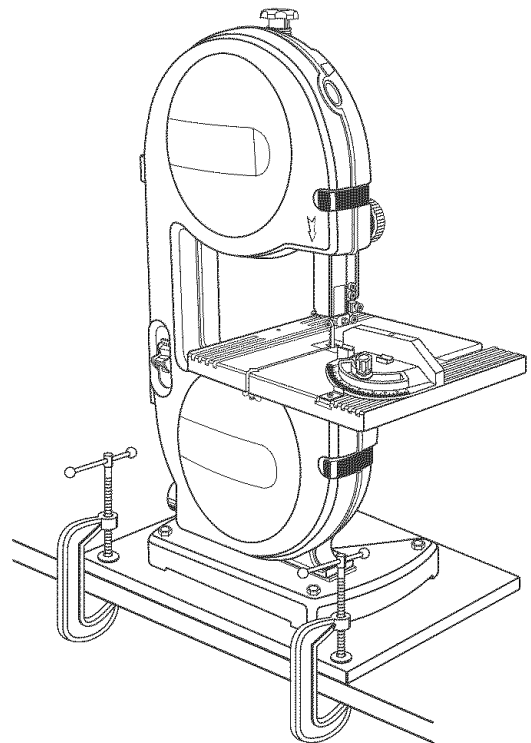

Fig. 7

# ASSEMBLY

## ADJUSTING BLADE GUIDE ASSEMBLY

See Figure 8.

**WARNING:** To avoid personal injury, maintain proper adjustment of blade tension, blade guides, and thrust bearings.

To prevent the blade from twisting or breaking, the blade guide assembly should always be set approximately 1/8 in. above the workpiece.

- Turn the lock lever counterclockwise to unlock the blade guide assembly.
- As a guide, use a scrap piece of the same wood you are about to cut to set the height of the blade guide assembly. Adjust blade guide assembly by turning the blade guide knob.
- Lock blade guide assembly in place by turning the lock lever clockwise.
- Always lock the blade guide assembly in place before turning on the band saw.

## INSTALLING AND ADJUSTING THE BLADE

See Figures 9 - 10.

**WARNING:** Always wear safety goggles or safety glasses with side shields to protect your eyes while uncoiling band saw blades. Failure to heed this warning could result in a serious eye injury.

- Loosen and remove the wing nut and table aligning bolt from the saw table.
- Remove the saw table before opening the front cover of the saw housing.
- Loosen the two set screws that hold the blade guard in place using the 4 mm hex key provided, then remove the blade guard.
- Turn the lock lever counterclockwise to unlock the blade guide assembly. Turning the blade guide knob (clockwise raises the blade guide assembly; counterclockwise lowers it), position the blade guide assembly about halfway between the saw table and saw housing. Retighten the lock lever.
- Release blade tension by loosening the 8 mm hex nut then turning the blade tension knob counterclockwise.
- Carefully remove the old blade.

**NOTE:** The spring on the upper wheel allows the wheel to be pulled down for easier removal of the blade.

- Wearing gloves, carefully uncoil the blade at arm's length. If the new blade was oiled to prevent rusting, it may need to be wiped to keep the oil from your workpiece. Carefully wipe in the same direction the teeth are pointing so the rag does not catch on the teeth of the saw blade.

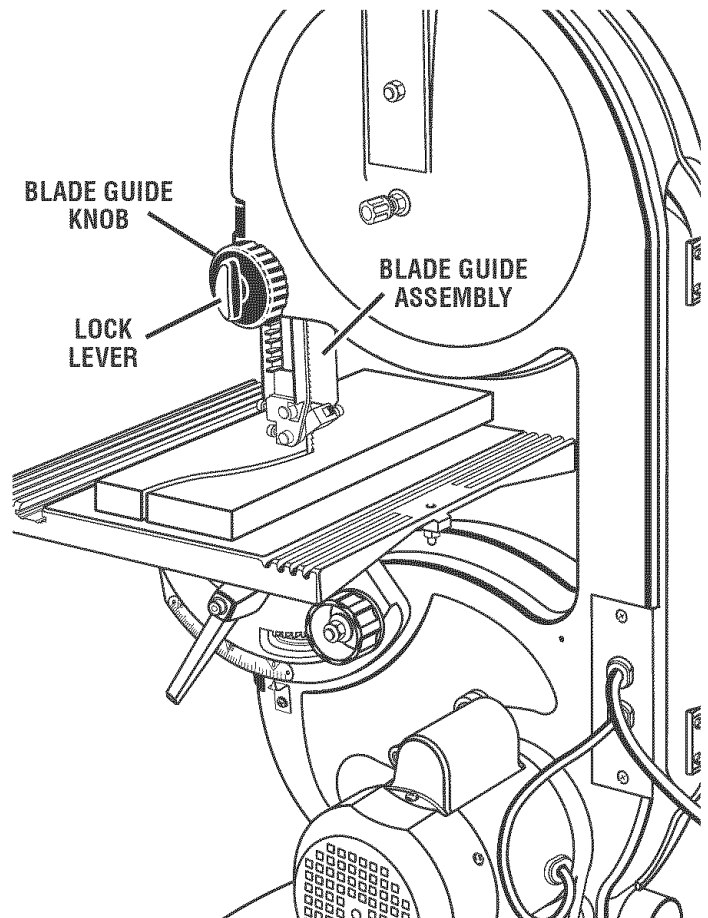

Fig. 8

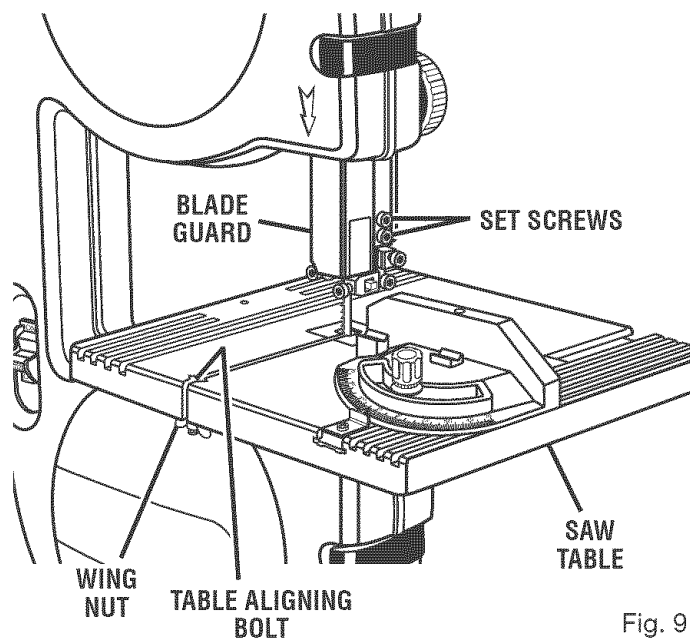

Fig. 9

# ASSEMBLY

**NOTE:** The blade may need to be turned inside out if the teeth are pointing in the wrong direction. Hold the blade with both hands and rotate it inward.

- With the teeth of the blade toward the front of the saw and facing downward, place the blade through the lower blade guides and around the lower wheel. Pull down on the upper wheel to place the saw blade on the wheel.
- Slowly turn the upper wheel to the right or clockwise by hand to center the blade on the rubber tires.
- Adjust the blade tension. Check or adjust the blade tracking.
- Adjust both upper and lower blade guides and thrust bearings. See page 16.
- Reattach the saw table and the aligning bolt, washer, and wing nut. Tighten securely.
- Reattach the blade guard.
- Close front cover.

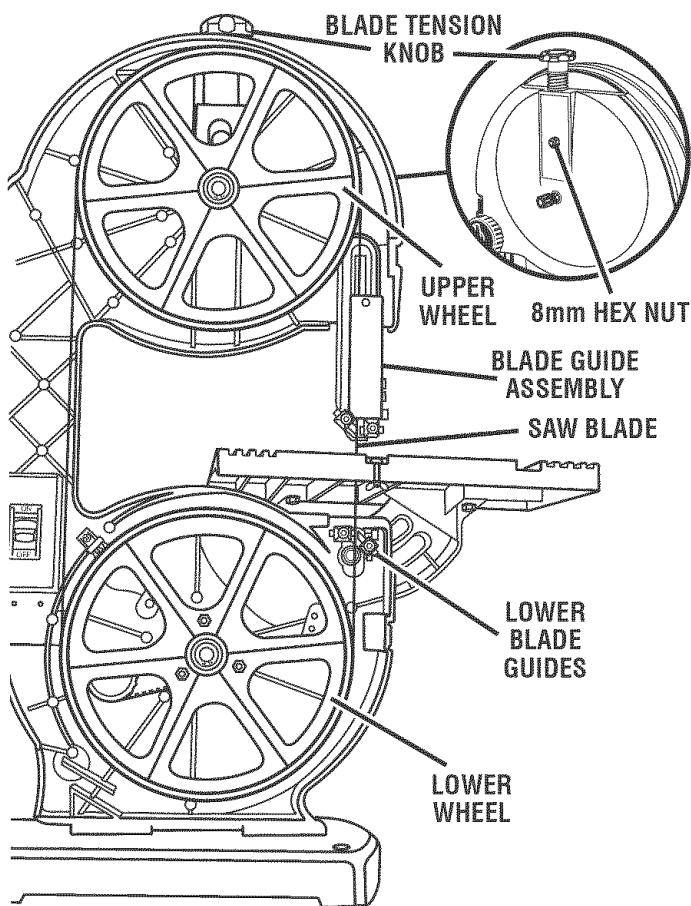

Fig.10

## ADJUSTING BLADE TENSION

See Figures 10 - 11.

- Turn off and unplug the saw. Remove the switch key.
- Before using the band saw, turn the blade tension knob on the top of the saw clockwise to engage tension.
- To check tension, raise the blade guide assembly all the way up to expose the blade.
- Push the blade to the side with moderate force; the blade should flex approximately 1/8 in.

**NOTE:** Adjustments of blade tension can be made at anytime.

Another method of checking blade tension has to do with the sound the blade makes when plucked like a guitar string.

- Pluck the back straight edge on the coasting side opposite the blade guides while turning the tension knob. Sound should be a musical note. Sound becomes higher pitched as tension increases.

Using either method to check blade tension can be developed with practice.

- Never increase blade tension so tight as to completely compress the spring. When completely compressed, the spring can no longer act as a shock absorber.

**NOTE:** Too much tension may cause the blade to break. Too little tension may cause the blade to slip on the wheels.

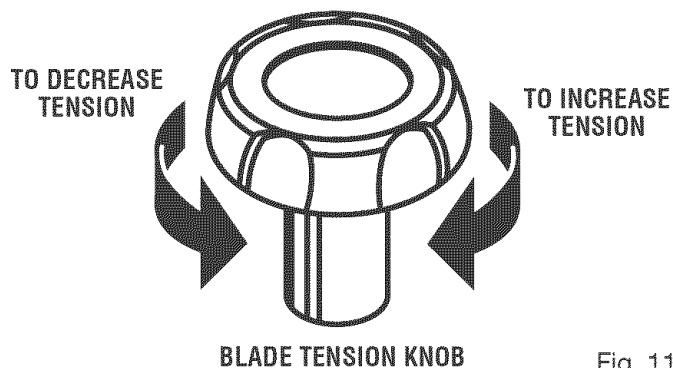

Fig. 11

## TRACKING THE BLADE

See Figure 12.

**NOTE:** Adjust blade tension properly before making tracking adjustments. Check that the blade guides are not interfering with the blade.

**To Adjust:**

- Open the front cover by releasing the upper and lower latches. Watch the blade's position on the upper tire through the tracking view window as, by hand, you slowly turn the upper wheel clockwise. If the blade moves away from the center of the tire, the tracking must be adjusted.

# ASSEMBLY

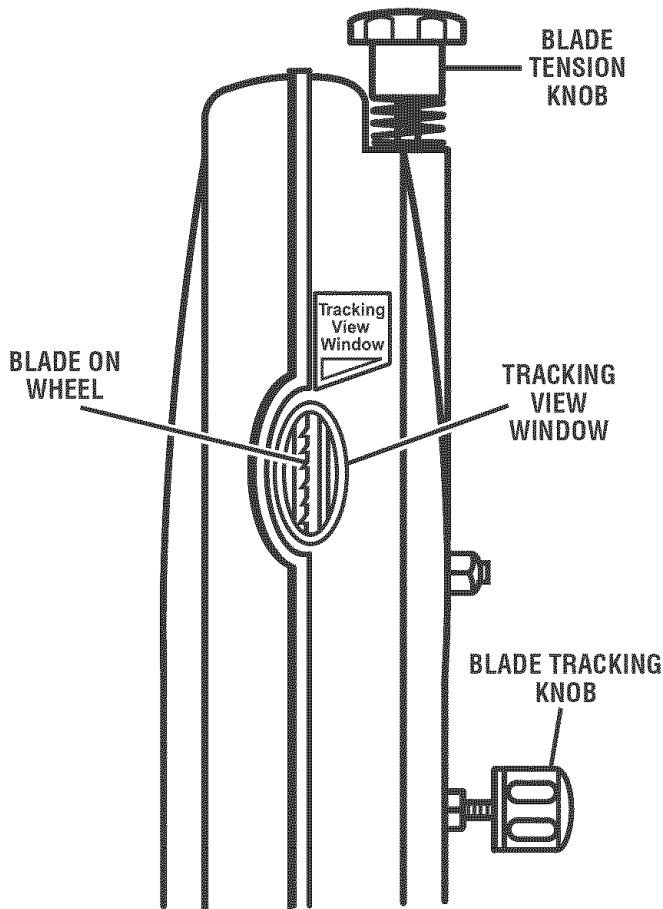

Fig. 12

## If the blade has moved left or right of center:

- Turn the blade tracking knob (clockwise if blade has moved left and counterclockwise if blade has moved right) while turning the wheel by hand until the blade moves back and rides in the center of the tire.
- Check the position of the blade on the lower tire. The blade should be completely on the tire. If not, adjust the tracking until the blade is on both tires.
- Rotate the upper wheel by hand in a clockwise direction for a few more turns. Make sure the blade stays in the same location on the tires. Readjust, if necessary, until blade is tracking properly.
- Close front cover and relatch.

**NOTE:** The 1/8 in. blade may not track properly in the center of the wheel. It may be better to track this blade on the back half of the upper wheel.

## SQUARING THE SAW TABLE TO THE BLADE

See Figure 13.

- Remove the blade guard by loosening the two set screws with the 4 mm hex key.
- Turn the lock lever counterclockwise to unlock the blade guide assembly. Turning the blade guide knob clockwise, raise the blade guide assembly as far as it will go. Retighten the blade guide knob.
- Place a small combination square on the saw table beside the blade.
- Loosen the table lock handle and rotate the angle adjustment knob to tilt the saw table up or down to align table 90° to blade (0° position). Retighten the table lock handle.
- Using an adjustable wrench, adjust the zero stop set screw until the set screw just touches the saw housing.
- Check squareness of the saw table to the blade. Make readjustments if necessary.
- Loosen screw on scale indicator with a phillips screwdriver and align scale indicator to zero.
- Tighten all screws securely.
- Replace the blade guard once the saw table has been squared.

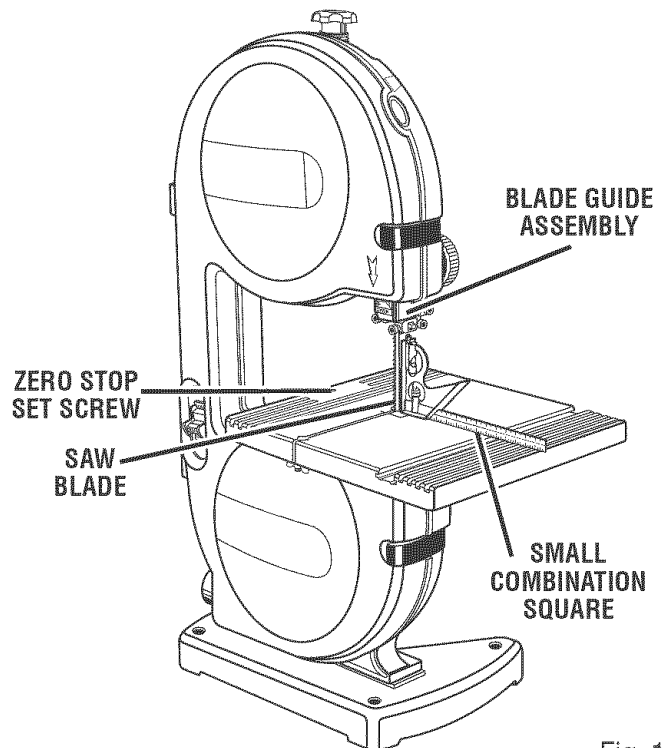

Fig. 13

# ASSEMBLY

## ADJUSTING THRUST BEARINGS, BLADE GUIDE SUPPORT, AND BLADE GUIDES

See Figures 14 - 16.

**WARNING:** Never operate saw without blade guard secured in place. To do so could result in possible serious personal injury.

The upper and lower blade guides and thrust bearings support the band saw blade during cutting operations. The adjustment of the guides and bearings should be checked whenever a different blade is installed.

### To Adjust Thrust Bearings:

The thrust bearings support the back edge of the blade during cutting. The blade should not contact the thrust bearings when you stop cutting. It is important that both upper and lower thrust bearings be adjusted equally.

**NOTE:** The thrust bearing screw is the upper cap screw located on the right side of the blade guide assembly. It is the lower cap screw on the right side of the saw housing below the saw table for the lower bearing.

- Remove the blade guard by loosening the two set screws with the 4 mm hex key.
- Turn the lock lever counterclockwise to unlock the blade guide assembly. Turning the blade guide knob (clockwise raises the blade guide assembly, counterclockwise lowers it), position the blade guide assembly about halfway between the saw table and saw housing. Retighten the lock lever.

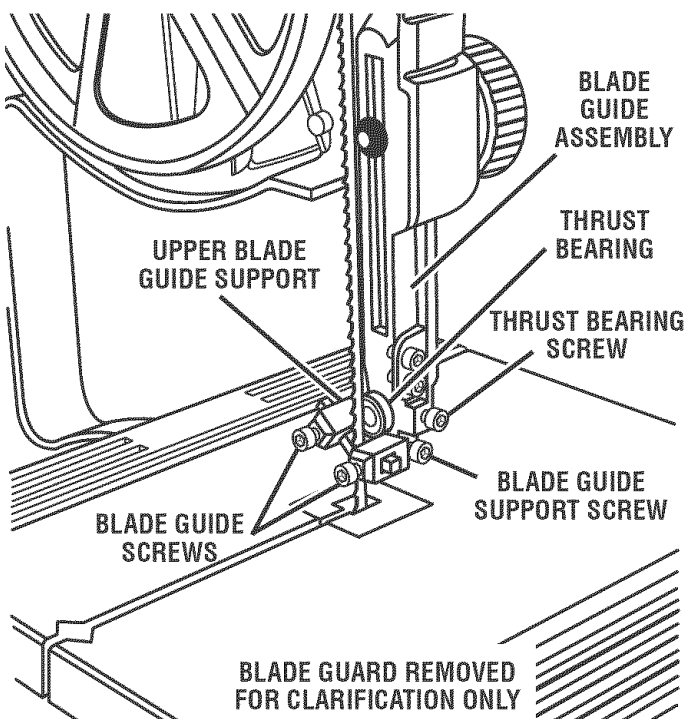

Fig. 14

- Adjust the thrust bearings first. Using the 4 mm hex key, loosen the thrust bearing screw.
- Move the thrust bearing to within 1/64 in. of the blade. Tighten the thrust bearing screw securely. Repeat this procedure on the lower thrust bearing located below the saw table.
- Replace the blade guard if no additional adjustments are to be made.

### To Adjust Blade Guide Support:

- Remove the blade guard by loosening the two set screws with the 4 mm hex key.
- Adjust the position of the blade guide assembly. Loosen the bottom screw on the right side of the blade guide assembly using the 4 mm hex key.
- Slide the upper blade guide support on the shaft until the front edge of the blade guides are about 1/64 in. behind the gullet of the blade. Tighten the screw securely. Repeat this procedure for the lower blade guide support.
- Replace the blade guard if no additional adjustments are to be made.

**NOTE:** The lower blade guide support screw is the top screw located on the right of the saw housing under the table.

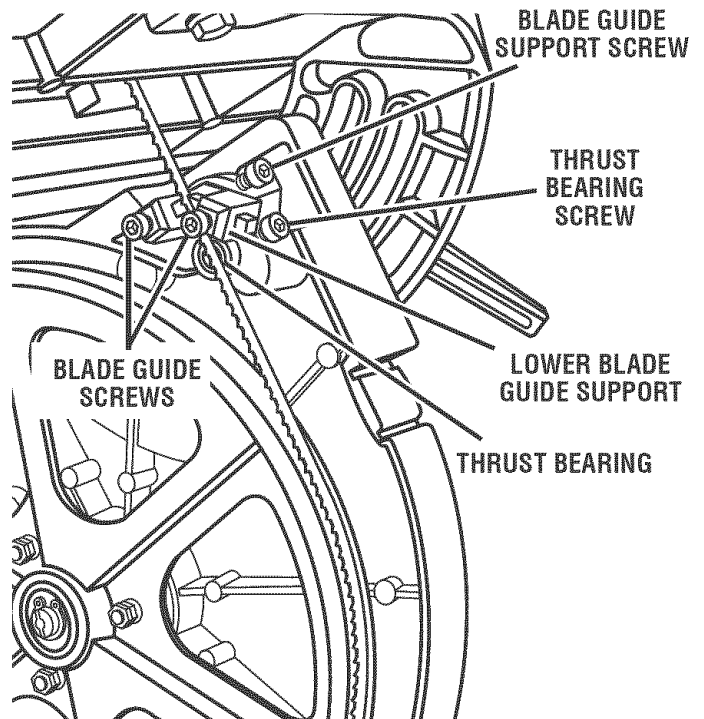

Fig. 15

# ASSEMBLY

## To Adjust Blade Guides:

The blade guides help keep the blade from twisting and binding. The blade will be ruined if the blade teeth hit the blade guides while using the band saw. The set of teeth and the sharpened edge of teeth will be damaged by hitting the blade guides. Proper adjustment of the upper and lower blade guides will prevent this from happening.

- Remove the blade guard by loosening the two screws set with the 4 mm hex key.
- Loosen the two blade guide support screws that lock the upper blade guides. Slide the two guides to within 1/32 in. of the blade. Do not pinch the blade. Make sure one guide is not further away from the blade than the other. Retighten the two blade guide support screws securely.
- Replace the blade guard if no additional adjustments are to be made.
- Repeat this procedure on the lower blade guides located under the saw table.

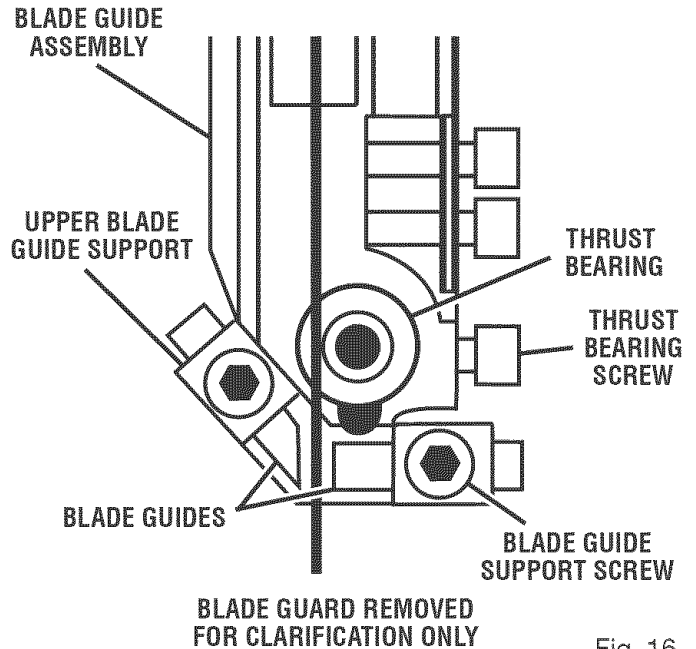

Fig. 16

# OPERATION

- ⚠ **WARNING:** Do not allow familiarity with tools to make you careless. Remember that a careless fraction of a second is sufficient to inflict severe injury.
- ⚠ **WARNING:** Always wear safety goggles or safety glasses with side shields when operating tools. Failure to do so could result in objects being thrown into your eyes resulting in possible serious injury.
- ⚠ **WARNING:** Do not use any attachments or accessories not recommended by the manufacturer of this tool. The use of attachments or accessories not recommended can result in serious personal injury.

## APPLICATIONS

This product has been designed only for the purposes listed below:

- Scroll cutting and circle cutting of wood and wood composition products
- Relief cutting of wood and wood composition products

- ⚠ **WARNING:** Before starting any cutting operation, clamp or bolt the band saw to a workbench. Never operate the band saw on the floor or in a crouched position. Failure to heed this warning can result in serious personal injury.

## BASIC OPERATION OF THE BAND SAW

A band saw is basically a "curve cutting" machine that can also be used for straight-line cutting operations like cross cutting, ripping, mitering, beveling, compound cutting, and resawing. It is not capable of making inside or non-through cuts.

This band saw is designed to cut wood and wood composition products only.

Before starting a cut, watch the saw run. If you experience excessive vibration or unusual noise, stop immediately. Turn the saw off, remove the switch key, and unplug the saw. Do not restart until locating and correcting the problem.

## CUTTING PROCEDURES

- Hold the workpiece firmly against the saw table.
- Use gentle pressure and both hands when feeding the work into the blade. Do **not** force the work; allow the blade to cut.
- The smallest diameter circle that can be cut is determined by blade width. A 1/4 in. wide blade will cut a minimum diameter of 1-1/2 in.; a 1/8 in. wide blade will cut a minimum diameter of 1/2 in.
- Keep your hands away from the blade. Do not handle pieces so small your fingers will go under the blade guard.

# OPERATION

- Avoid awkward operations and hand positions where a sudden slip could cause serious injury from contact with the blade. Never place hands in blade path.
- Use extra supports (tables, saw horses, blocks, etc.) when cutting large, small, or awkward workpieces.
- Never use a person as a substitute for a table extension or as additional support for a workpiece that is longer or wider than the basic saw table.
- When cutting irregularly shaped workpieces, plan your work so it will not pinch the blade. For example, a piece of molding must lie flat on the saw table. Workpieces must not twist, rock or slip while being cut.

When backing up the workpiece, the blade may bind in the kerf (cut). This is usually caused by sawdust clogging the kerf or when the blade comes out of the guides. If this happens:

- Wait until the saw has come to a full and complete stop.
- Place the switch in the **OFF** position then remove the switch key from the switch assembly. Store key in a safe place.
- Unplug the saw from the power source.
- Wedge the kerf open with a flat screwdriver or wooden wedge.
- Open front cover and turn the upper wheel by hand while backing up the workpiece.

## RELIEF CUTS

Relief cuts are made when an intricate curve (too small a radius for the blade) is to be cut. Cut through a scrap section of the workpiece to curve in pattern line then carefully back the blade out. Several relief cuts should be made for intricate curves before following the pattern line as sections are cutoff of curve “relieving” blade pressure.

## SCROLL CUTTING

For general type scroll cutting, follow the pattern lines by pushing and turning the workpiece at the same time. Do not try to turn the workpiece while engaged in the blade without pushing it, the workpiece could bind or twist the blade.

## REMOVING JAMMED MATERIAL

Never remove jammed cutoff pieces until the blade has come to a full and complete stop.

- Place the switch in the **OFF** position, remove the switch key from the switch assembly.
- Unplug the saw from the power source before removing jammed material.

## AVOIDING INJURY

- Make sure saw is level and does not rock. Saw should always be on a firm, level surface with plenty of room for handling and properly supporting the workpiece.
- Bolt saw to the support surface to prevent slipping, walking, or sliding during operations like cutting long, heavy boards.
- Turn saw off, remove switch key, and unplug cord from the power source before moving the saw.
- Do not remove jammed cutoff pieces until blade has come to a full and complete stop.
- Choose the right size and style blade for the material and type of cut you plan to do.
- Make sure that the blade teeth point down toward the saw table, that the blade guides, thrust bearings, and blade tension are properly adjusted, that the blade guide knob is tight, and that no parts have excessive play.
- To avoid accidental blade contact, minimize blade breakage, and provide maximum blade support, always adjust the blade guide assembly to just clear the workpiece.
- Use only recommended accessories.
- With the exception of the workpiece and related support devices, clear everything off the saw table before turning the saw on.
- Properly support round materials such as dowel rods or tubing because they have a tendency to roll during a cut causing the blade to “bite.” To avoid this, always use a “V” block or clamp workpiece to a miter gauge.
- Before removing loose pieces from the saw table, turn saw off and wait for all moving parts to stop.

# OPERATION

## BEFORE LEAVING THE SAW

See Figure 17.

- Wait until the saw has come to a full and complete stop.
- Place the switch in the **OFF** position, remove the switch key from the switch assembly. Store key in a safe place.
- Unplug the saw from the power source.
- Make workshop childproof.
- Lock the shop.

## LOCKING THE SWITCH

See Figure 17.

- Wait until the saw has come to a full and complete stop.

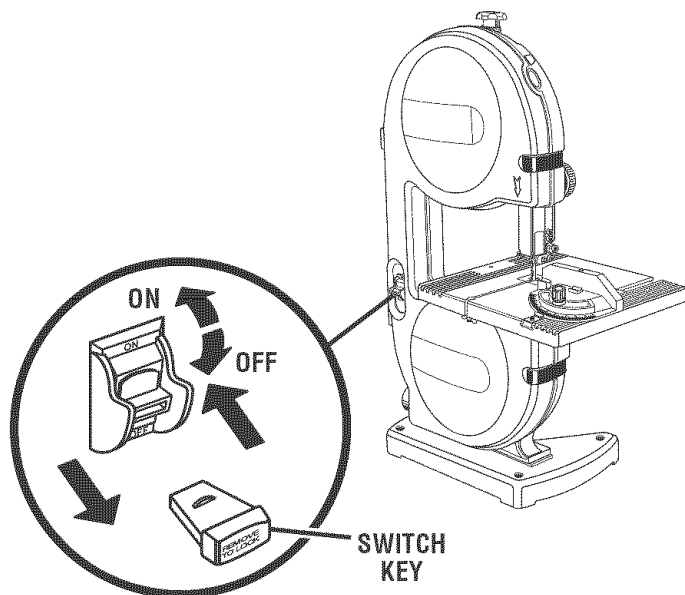

Fig. 17

- Place the switch in the **OFF** position, remove the switch key from the switch assembly. Store key in a safe place.

## TILTING THE TABLE

See Figure 18.

- Loosen the table lock handle slightly.
- Turn the angle adjustment knob, tilting the saw table toward the front of the saw housing until it reaches the desired angle.
- Using the scale indicator, check angle markings.
- Retighten the table lock handle to hold saw table securely in place.

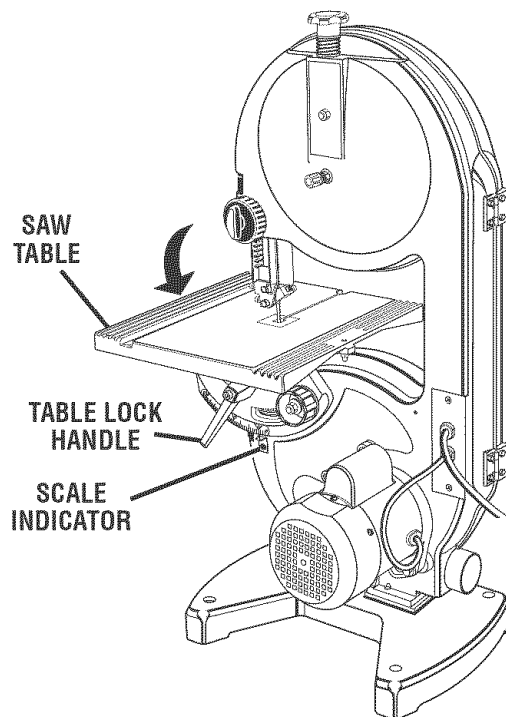

Fig. 18

## USING THE MITER GAUGE

See Figure 19.

The miter gauge can be turned 45° to the right or left.

- Loosen the lock knob on the miter gauge.
- With the miter gauge in the miter gauge slot, rotate the gauge until the desired angle is reached on the index scale.
- Retighten the lock knob.

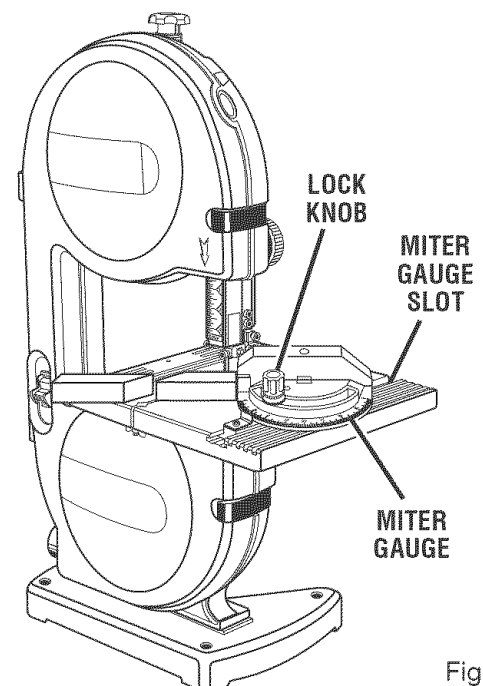

Fig. 19

# MAINTENANCE

**WARNING:** When servicing, use only identical replacement parts. Use of any other part may create a hazard or cause product damage.

**WARNING:** Always wear safety goggles or safety glasses with side shields during power tool operation or when blowing dust. If operation is dusty, also wear a dust mask.

## GENERAL

Avoid using solvents when cleaning plastic parts. Most plastics are susceptible to damage from various types of commercial solvents and may be damaged by their use. Use clean cloths to remove dirt, carbon dust, etc.

**WARNING:** Do not at any time let brake fluids, gasoline, petroleum-based products, penetrating oils, etc. come in contact with plastic parts. Chemicals can damage, weaken or destroy plastic which may result in serious personal injury.

It has been found that electric tools are subject to accelerated wear and possible premature failure when they are used on fiberglass boats, sports cars, wallboard, spackling compounds, or plaster. The chips and grindings from these materials are highly abrasive to electric tool parts such as bearings, brushes, commutators, etc. Consequently, it is not recommended that this tool be used for extended work on any fiberglass material, wallboard, spackling compounds, or plaster. During any use on these materials it is extremely important that the tool is cleaned frequently by blowing with an air jet.

- Keep your band saw clean.
- Remove sawdust from the inside frequently.
- Do not allow pitch to accumulate on the saw table, blade guides, or thrust bearings. Clean them with gum and pitch remover.
- Apply a thin coat of automobile type wax to the saw table's top so the wood slides easily while cutting.

## LUBRICATION

All of the bearings in this tool are lubricated with a sufficient amount of high grade lubricant for the life of the unit under normal operating conditions. Therefore, no further lubrication is required.

**WARNING:** To ensure safety and reliability, all repairs — with the exception of the externally accessible brushes — should be performed by a qualified service technician at a Sears store to avoid risk of personal injury.

## TIRES

### Cleaning tires:

- Pitch and sawdust accumulates on tires and needs to be removed with a fine wire brush or a piece of wood. **Do not** use a sharp knife or any kind of solvent.

### Replacing tires:

- Open front cover and remove saw blade. See section on **Installing and Adjusting the Blade**, page 14.
- Pry the worn tire away from the wheel carefully.
- Stretch the new tire around the wheel.
- Replace the saw blade and close the front cover.

## BLADE GUIDES

See Figure 20.

Blade guides may become rounded and worn during use.

- Unplug the band saw.
- Remove the blade guides and file or grind flat.
- Replace blade guides when filing or grinding has worn them down and they can no longer be properly secured in place.

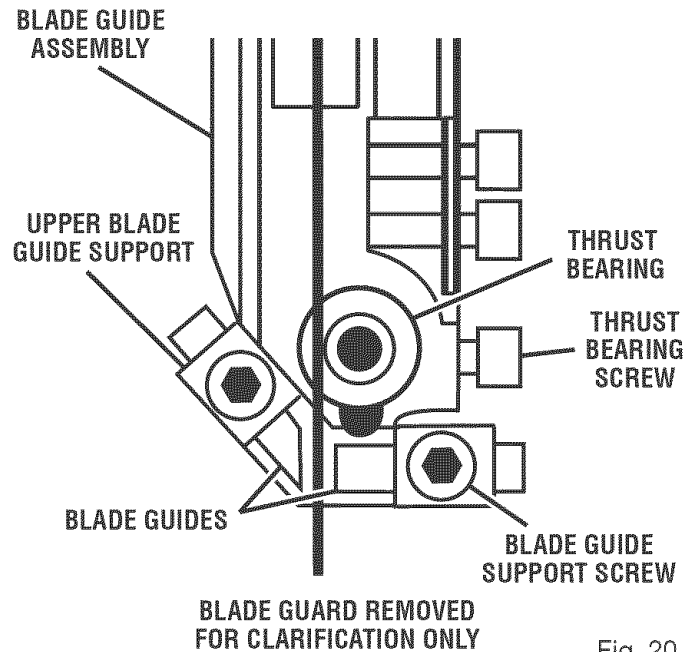

Fig. 20

# MAINTENANCE

## MOTOR/ELECTRICAL

- Frequently vacuum or blow out sawdust from the motor.

**WARNING:** If the power cord is worn, cut or damaged in any way, have it replaced immediately by a qualified service technician. Failure to do so could result in serious personal injury.

**WARNING:** To avoid fire or electrocution, reassemble electric parts with only identical replacement parts. Reassemble exactly as originally assembled.

## BRUSHES

See Figure 21.

The saw has accessible brush assemblies that should be periodically checked for wear.

- Unplug the band saw.
- Remove the screw and washer then pull the brush off.
- Place the new brush in the groove with the plastic tabs under the saw housing.
- Retighten using the washer and screw.

## DRIVE BELT

See Figures 22 - 23.

**WARNING:** To prevent accidental starting that could cause possible serious personal injury, turn off the saw, remove the switch key, and unplug the saw before working on the band saw.

Due to wear or breakage, the drive belt may need to be replaced. The drive belt is located behind the lower wheel of the band saw.

- Unplug the band saw.
- Remove the saw blade and set it aside. See section on **Installing and Adjusting the Blade**, page 14.
- Remove the nut and washer from the middle of the saw housing.
- Pull the lower wheel away from the saw housing.
- Remove the worn drive belt.
- Place new drive belt on the pulley. As you slide the pulley shaft back into the hole in the saw housing, place the drive belt over the motor pulley.
- Replace the nut and washer on the pulley shaft and retighten.
- Replace saw blade.
- Check thrust bearings and blade guides.

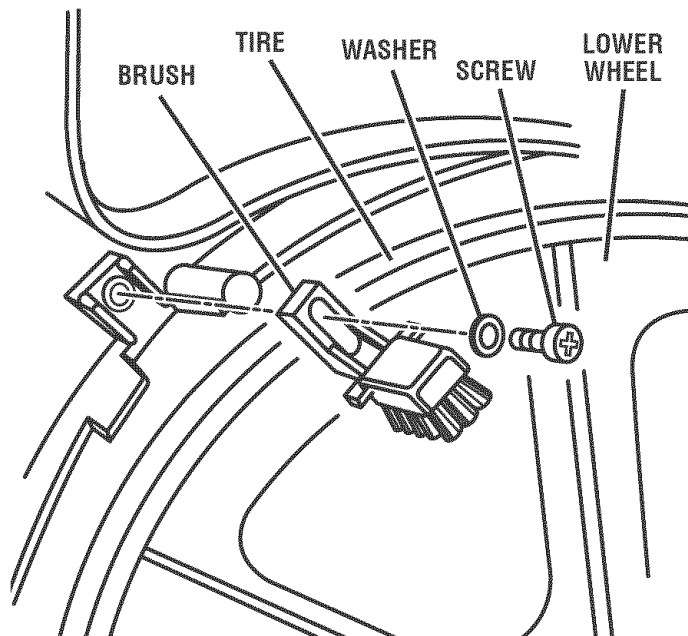

Fig. 21

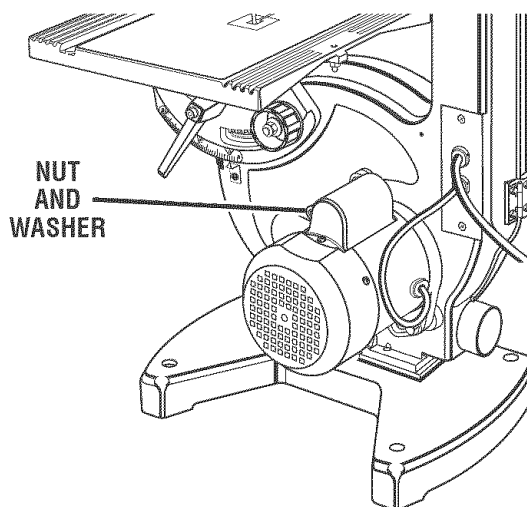

Fig. 22

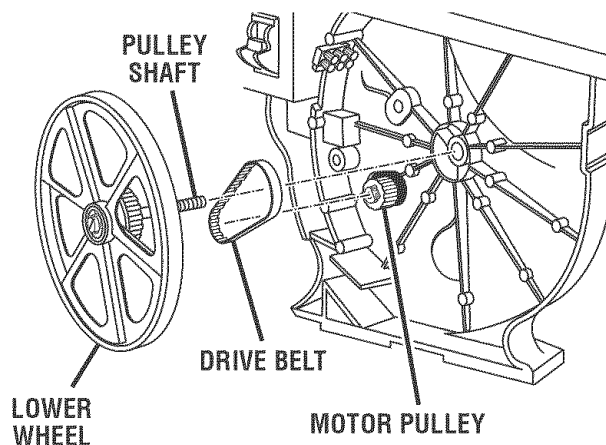

Fig. 23

# TROUBLESHOOTING

PROBLEM	CAUSE	SOLUTION
Motor will not run.	<ol style="list-style-type: none"> <li>1. Problem with On-Off switch or power cord.</li> <li>2. Motor defective.</li> </ol>	<ol style="list-style-type: none"> <li>1. Have worn parts replaced before using band saw again.</li> <li>2. Do not attempt any repair. Have tool repaired by a qualified service technician.</li> </ol>
Blade does not run in the approximate center of the upper wheel.	<ol style="list-style-type: none"> <li>1. Not tracking properly.</li> </ol>	<ol style="list-style-type: none"> <li>1. Adjust tracking. See <i>Adjustments</i> section, <b>Tracking the Blade</b>.</li> </ol>
Band saw slows down when cutting.	<ol style="list-style-type: none"> <li>1. Cutting too small a radius.</li> <li>2. Dull blade.</li> </ol>	<ol style="list-style-type: none"> <li>1. Stop feeding and back up the material slightly until the band saw speeds up.</li> <li>2. Replace blade.</li> </ol>
Blade breaking.	<ol style="list-style-type: none"> <li>1. Too much blade tension.</li> <li>2. Kink in blade caused by cutting too small radius or turning the material too fast when cutting.</li> <li>3. Thrust bearings scarred or not rotating.</li> </ol>	<ol style="list-style-type: none"> <li>1. Adjust tension. See <i>Adjustments</i> section, <b>Adjusting Blade Tension</b>.</li> <li>2. Use correct cutting technique. See section, <i>Operation</i>.</li> <li>3. Replace the thrust bearings. See <b>Adjusting Thrust Bearings</b>.</li> </ol>
Saw is noisy when running.	<ol style="list-style-type: none"> <li>1. Too much blade tension.</li> <li>2. Blade guides and bearings are in contact with the blade.</li> </ol>	<ol style="list-style-type: none"> <li>1. Adjust tension. See <i>Adjustments</i> section, <b>Adjusting Blade Tension</b>.</li> <li>2. Adjust upper and lower blade guides and bearings. See <i>Adjustments</i> sections, <b>Adjusting Thrust Bearings, Blade Guide Support, and Blade Guides</b>.</li> </ol>
Blade will not cut straight.	<ol style="list-style-type: none"> <li>1. Blade guides and bearings not properly adjusted.</li> <li>2. Worn or defective blade.</li> </ol>	<ol style="list-style-type: none"> <li>1. Adjust upper and lower blade guides and bearings. See <i>Adjustments</i> sections, <b>Adjusting Thrust Bearings, Blade Guide Support, and Blade Guides</b>.</li> <li>2. Replace blade.</li> </ol>
Blade guides will not stay in position.	<ol style="list-style-type: none"> <li>1. Blade guide screws have loosened.</li> </ol>	<ol style="list-style-type: none"> <li>1. Tighten blade guide screws securely.</li> </ol>



CRAFTSMAN BAND SAW – MODEL NO. 315.214770

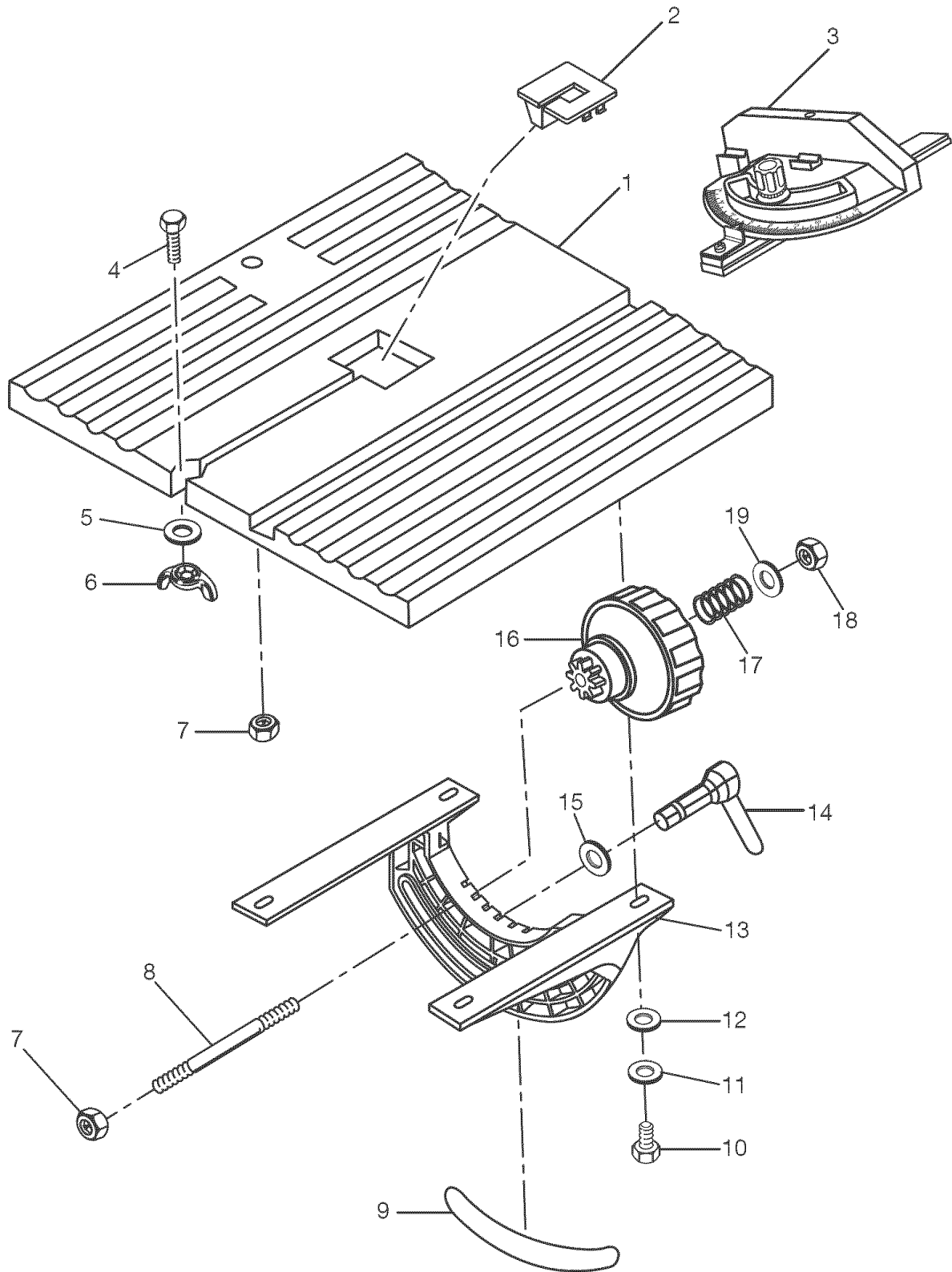

FIGURE A



# CRAFTSMAN BAND SAW – MODEL NO. 315.214770

The model number will be found on a plate attached to the housing. Always mention the model number in all correspondence regarding your band saw or when ordering repair parts.

## SEE BACK PAGE FOR PARTS ORDERING INSTRUCTIONS

### PARTS LIST FOR FIGURE A

Key No.	Part Number	Description	Qty
1	BS90105900	Table (290 mm x 290 mm x 22 mm) .....	1
2	089120100014	Throat Plate (38 mm x 38 mm) .....	1
3	089120100805	Miter Gauge Assembly .....	1
4	089120100018	* Hex Screw (M5 x 25 mm) .....	1
5	089120100026	* Washer (M5 x 9) **STD851005 .....	1
6	089120100019	* Wing Nut (M5) .....	1
7	BS90105800	* Nut (M6) .....	2
8	BS90108200	* Bolt (M6).....	1
9	089120100900	Angle Scale Label .....	1
10	BS90105100	* Bolt (M6 x 16 mm).....	4
11	BS90105200	* Spring Washer (M6) **STD852006 .....	4
12	BS90105300	* Washer (M6 x 12) **STD851006.....	4
13	BS90105400	Trunnion Bracket.....	1
14	089120100700	Table Locking Handle Assembly .....	1
15	BS90105500	* Washer (M10 x 18) **STD851010.....	1
16	089120100025	Bevel Knob.....	1
17	BS90108400	Spring (1 x 15 x 28L) .....	1
18	BS90108500	* Nylon Nut (M6) .....	1
19	BS90107400	* Washer (M6 x 18) .....	1

\* Standard Hardware Item – May Be Purchased Locally

\*\* Available From Div. 98 – Source 980.0

\*\*\* Complete assortment available at your Nearest Sears Retail Store



**CRAFTSMAN BAND SAW – MODEL NO. 315.214770**

The model number will be found on a plate attached to the housing. Always mention the model number in all correspondence regarding your band saw or when ordering repair parts.

**SEE BACK PAGE FOR PARTS ORDERING INSTRUCTIONS**

**PARTS LIST FOR FIGURE B**

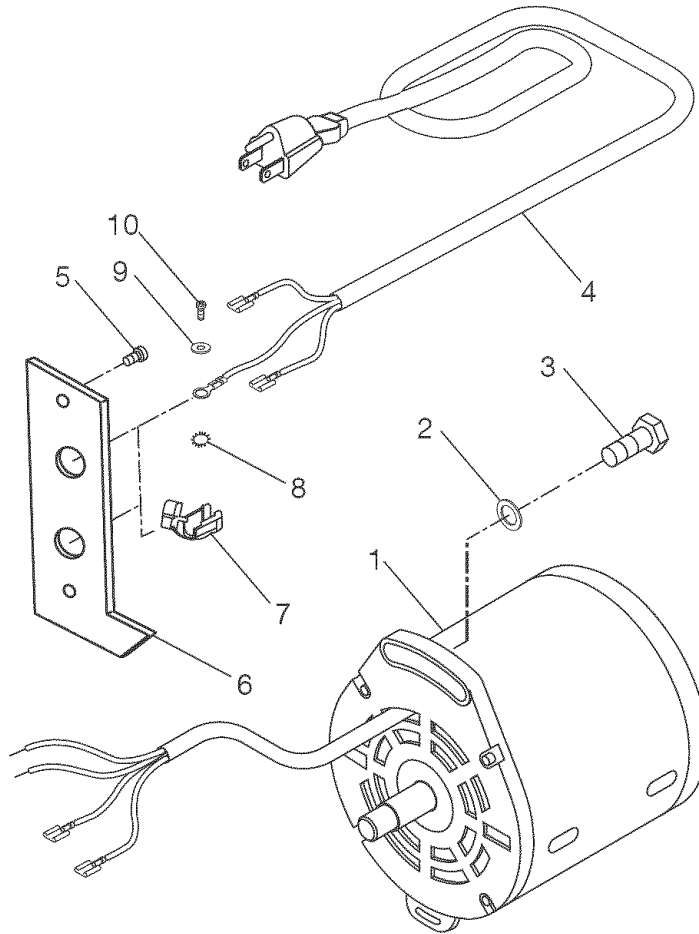

**FIGURE B**

Key Part No.	Part Number	Description	Qty
1	BS90106800	Motor Assembly.....	1
2	BS90104800	* Washer (M8 x 22) **STD851008.....	2
3	BS90106700	* Bolt (M8 x 25 mm) .....	2
4	BS90108000	Power Cord (SJP18AWG/3c/6ft).....	1
5	BS90103900	* Screw (M4 x 10 mm Flat Hd.) .....	2
6	089120100024	Fixing Plate .....	1
7	BS90108100	Strain Relief.....	2
8	089120100037	* Star Washer (M4) .....	1
9	089120100036	Washer.....	1
10	089120100035	* Screw (M4 x 6 mm Pan Hd.).....	1

\* Standard Hardware Item – May Be Purchased Locally

\*\* Available From Div. 98 – Source 980.0

\*\*\* Complete assortment available at your Nearest Sears Retail Store



# CRAFTSMAN BAND SAW – MODEL NO. 315.214770

The model number will be found on a plate attached to the housing. Always mention the model number in all correspondence regarding your band saw or when ordering repair parts.

**SEE BACK PAGE FOR PARTS ORDERING INSTRUCTIONS**

## PARTS LIST FOR FIGURE C

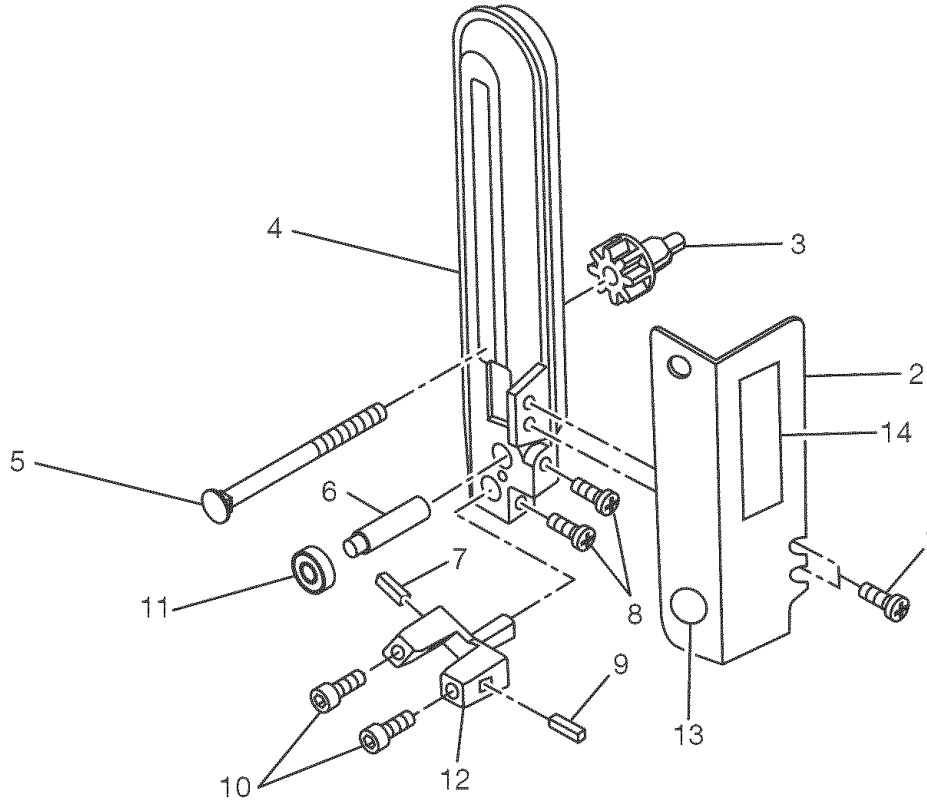

**FIGURE C**

Key No.	Part Number	Description	Qty
1	089120100006	* Hex Socket Head Screw (M5 x 8 mm)	2
2	BS90102400	Blade Guide	1
3	BS90101700	Gear	1
4	BS90101600	Bracket	1
5	BS90101500	* Carriage Bolt (M6 x 66 mm)	1
6	BS90101900	Pin	1
7	BS90102000	Guide (B)	1
8	089120100032	* Hex Socket Head Screw (M5 x 15 mm)	1
9	BS90102200	Guide (A)	1
10	089120100005	* Hex Socket Head Screw (M5 x 12 mm)	2
11	BS90101800	* Ball Bearing (625ZZ)	1
12	BS90102300	Upper or Lower Guide Bracket	1
13	089120100905	No Hands Label	1
14	089120100906	Depth Scale Label	1

\* Standard Hardware Item – May Be Purchased Locally

\*\* Available From Div. 98 – Source 980.0

\*\*\* Complete assortment available at your Nearest Sears Retail Store

CRAFTSMAN BAND SAW – MODEL NO. 315.214770

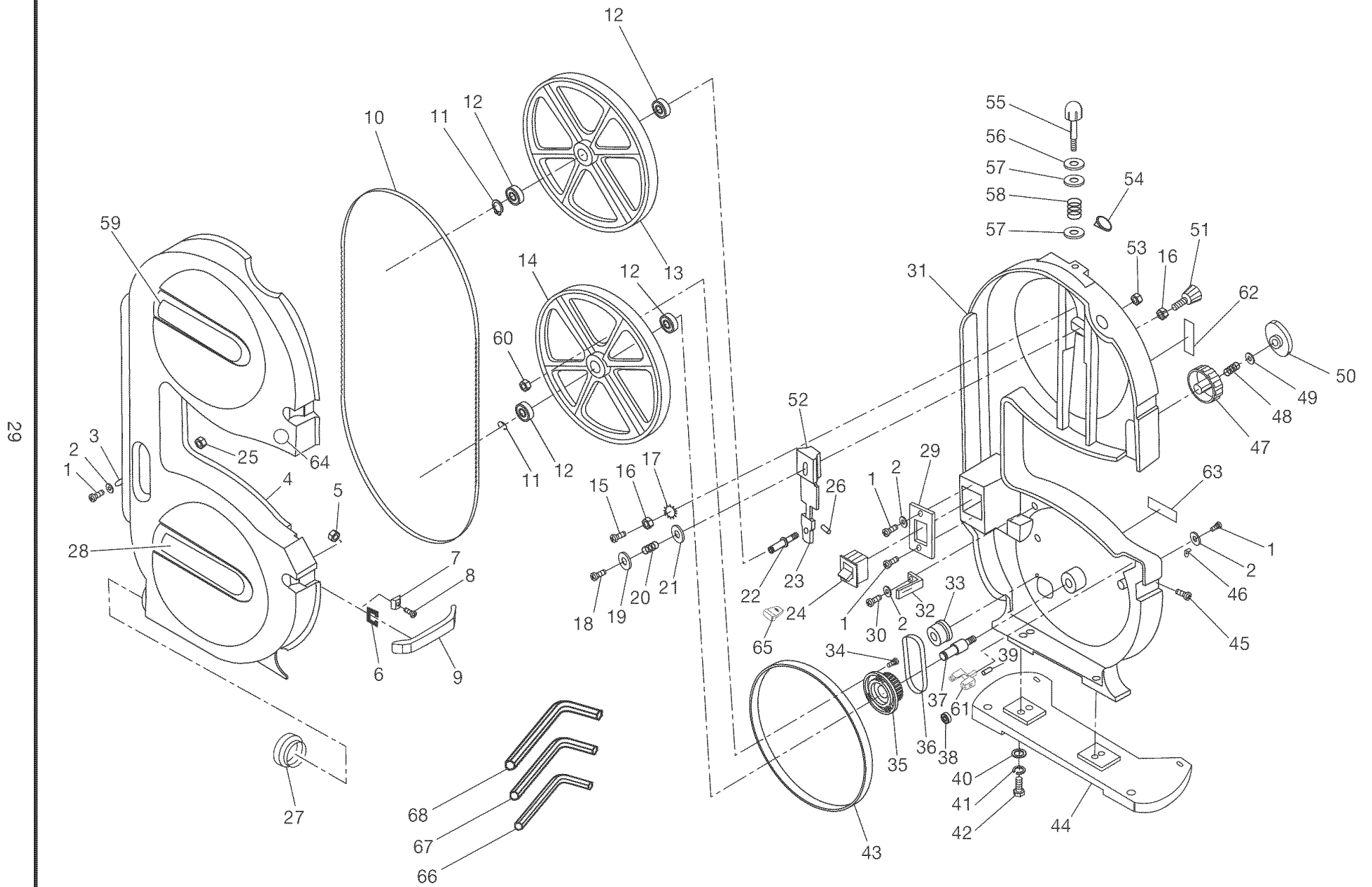

FIGURE D

## CRAFTSMAN BAND SAW – MODEL NO. 315.214770

The model number will be found on a plate attached to the housing. Always mention the model number in all correspondence regarding your band saw or when ordering repair parts.

### SEE BACK PAGE FOR PARTS ORDERING INSTRUCTIONS

### PARTS LIST FOR FIGURE D

Key No.	Part Number	Description	Qty
1	BS90100100	* Screw (M4 x 8 mm) .....	9
2	BS90100200	* Washer (M4 x 8) **STD851004.....	12
3	089120100001	Hinge.....	2
4	089120100002	Cover.....	1
5	BS90100500	* Nut (M3) .....	8
6	BS90100600	Retaining Spring .....	2
7	BS90100700	Clamp Bracket .....	2
8	089120100003	* Screw (M3 x 6 mm) .....	8
9	089120100004	Latch .....	2
10	BS90101000	*** Blade (1/4 in. x 59-1/4 in. x 0.012 x 6 TPI).....	3
11	BS90101100	Retaining Ring.....	2
12	BS90101200	Ball Bearing (6200ZZ) .....	4
13	BS90101300	Upper Wheel .....	1
14	BS90101400	Lower Wheel .....	1
15	089120100010	* Set Screw (M6 x 15 mm).....	3
16	BS90105800	* Nut (M6) **STD840610 .....	5
17	089120100028	* Star Washer (M6) .....	3
18	089120100011	* Hex Socket Screw (M6 x 45 mm) .....	1
19	BS90105300	* Washer (M6 x 12) **STD851006.....	2
20	089120100027	Spring (2 x 14 x 12L) .....	1
21	BS90103400	Special Washer (6 x 20 x 1.5T).....	1
22	BS90103500	Shaft.....	1
23	BS90103600	Adjusting Plate.....	1
24	BS90103800	Switch (J-9301) .....	1
25	BS90107000	* Nut (M4) **STD840407 .....	8
26	BS90103700	Elastic Pin .....	1
27	BS90108700	Dust Port Adapter (OD63.5 x OD55 mm).....	1
28	089120100902	Warning Label .....	1
29	BS90104000	Switch Plate .....	1
30	089120100031	* Screw (M4 x 12 mm Pan Hd.) .....	1
31	089120100008	Aluminum Housing.....	1
32	BS90104100	Brush.....	1
33	BS90104500	Pulley .....	1
34	089120100029	* Screw (M5 x 15 mm Flat Hd.) .....	3
35	BS90104300	Pulley .....	1

\* Standard Hardware Item – May Be Purchased Locally

\*\* Available From Div. 98 – Source 980.0

\*\*\* Complete assortment available at your Nearest Sears Retail Store



## CRAFTSMAN BAND SAW – MODEL NO. 315.214770

The model number will be found on a plate attached to the housing. Always mention the model number in all correspondence regarding your band saw or when ordering repair parts.

### SEE BACK PAGE FOR PARTS ORDERING INSTRUCTIONS

### PARTS LIST FOR FIGURE D

Key No.	Part Number	Description	Qty
36	BS90104400	Belt .....	1
37	BS90104600	Shaft .....	1
38	BS90101800	Ball Bearing (625ZZ) .....	1
39	BS90101900	Pin.....	1
40	BS90104800	* Washer (M8 x 22) **STD851008 .....	2
41	BS90104900	* Spring Washer (M8) **STD852008.....	2
42	089120100012	* Bolt (M8 x 22 mm) .....	4
43	BS90104900	Wheel Tire.....	2
44	BS90104700	Base.....	1
45	089120100005	* Hex Socket Screw (M5 x 12 mm).....	5
46	BS90106900	Pointer .....	1
47	089120100021	Adjusting Knob .....	1
48	BS90107500	Spring (1 x 12 x 18L).....	1
49	BS90107400	* Washer (M6 x 18) **STD851006 .....	1
50	089120100020	Lock Knob (M6) .....	1
51	089120100022	Tracking Knob (M6).....	1
52	BS90103100	Elevating Plate .....	1
53	BS90108500	* Nylon Nut (M6).....	1
54	089120100023	Tracking View Window.....	1
55	089120100007	Tension Knob (M6 x 70) .....	1
56	BS90102700	* Washer (M6).....	1
57	BS90102800	Washer.....	2
58	BS90102900	Spring (3 x 24 x 28L).....	1
59	089120100903	Logo Label.....	1
60	089120100030	Nylon Nut (M5).....	3
61	BS90102300	Upper or Lower Guide Bracket.....	1
62	089120100904	Tension Label.....	1
63	089120100901	Data Plate .....	1
64	089120100905	No Hands Label.....	1
65	BS90113800	Switch Key.....	1
66	BS90119800	3 mm Hex Key .....	1
67	BS90119900	4 mm Hex Key .....	1
68	BS90110000	5 mm Hex Key .....	1
	983000577	Operator's Manual (not shown) .....	1

\* Standard Hardware Item – May Be Purchased Locally

\*\* Available From Div. 98 – Source 980.0

\*\*\* Complete assortment available at your Nearest Sears Retail Store



# Get it fixed, at your home or ours!

## Your Home

For repair – **in your home** – of **all** major brand appliances, lawn and garden equipment, or heating and cooling systems, **no matter who made it, no matter who sold it!**

For the replacement parts, accessories and owner's manuals that you need to do-it-yourself.

For Sears professional installation of home appliances and items like garage door openers and water heaters.

**1-800-4-MY-HOME® (1-800-469-4663)**

Call anytime, day or night (U.S.A. and Canada)

[www.sears.com](http://www.sears.com)    [www.sears.ca](http://www.sears.ca)

---

## Our Home

For repair of carry-in items like vacuums, lawn equipment, and electronics, call or go on-line for the location of your nearest **Sears Parts & Repair Center.**

**1-800-488-1222**

Call anytime, day or night (U.S.A. only)

[www.sears.com](http://www.sears.com)

---

To purchase a protection agreement (U.S.A.) or maintenance agreement (Canada) on a product serviced by Sears:

**1-800-827-6655** (U.S.A.)

**1-800-361-6665** (Canada)

---

Para pedir servicio de reparación a domicilio, y para ordenar piezas:

**1-888-SU-HOGAR<sup>SM</sup>**

(1-888-784-6427)

Au Canada pour service en français:

**1-800-LE-FOYER<sup>MC</sup>**

(1-800-533-6937)

[www.sears.ca](http://www.sears.ca)

# SEARS

® Registered Trademark / <sup>TM</sup> Trademark / <sup>SM</sup> Service Mark of Sears, Roebuck and Co.

® Marca Registrada / <sup>TM</sup> Marca de Fábrica / <sup>SM</sup> Marca de Servicio de Sears, Roebuck and Co.

<sup>MC</sup> Marque de commerce / <sup>MD</sup> Marque déposée de Sears, Roebuck and Co.

© Sears, Roebuck and Co.