

# Operator's Manual

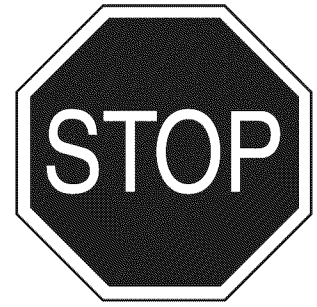

## 42"- 2 STAGE SNOW THROWER TRACTOR ATTACHMENT

Model No. 486.248371

DO NOT RETURN TO STORE  
For Missing Parts or Assembly  
Questions Call 1-866-576-8388

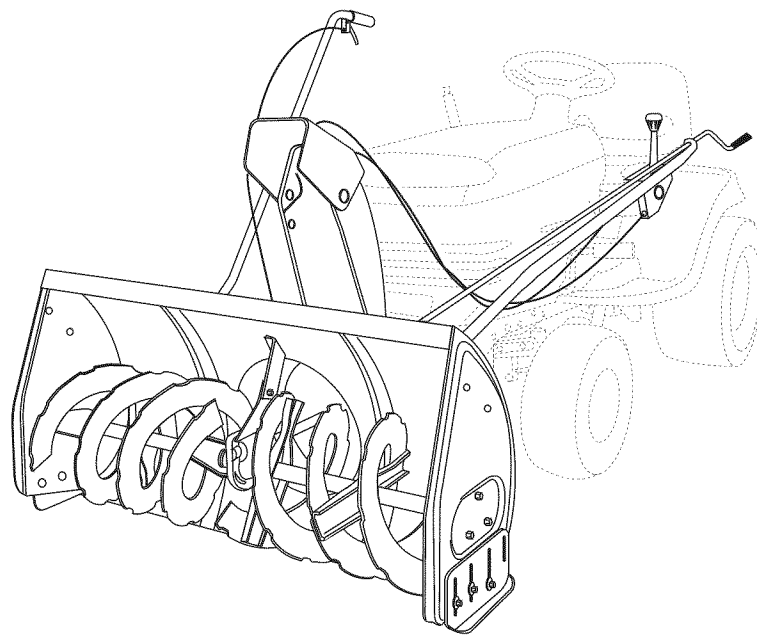

**FOR TRACTORS WITH MODEL NUMBERS BEGINNING WITH 247.**

### **CAUTION:**

Before using this product, read this manual and follow all Safety Rules and Operating Instructions.

- Safety
- Assembly
- Operation
- Maintenance
- Parts

Sears, Roebuck and Co., Hoffman Estates, IL 60179 U.S.A.  
[www.sears.com/craftsman](http://www.sears.com/craftsman)

PRINTED IN U.S.A.

FORM NO. 42317 (06/15/11)

## TABLE OF CONTENTS

ACCESSORIES.....2	SERVICE AND ADJUSTMENTS..... 18
SAFETY RULES.....3	STORAGE ..... 19
FULL SIZE HARDWARE CHART.....4	TROUBLESHOOTING.....20
CARTON CONTENTS.....6	REPAIR PARTS ILLUSTRATION..... 22, 24, 26
ASSEMBLY.....7	REPAIR PARTS LIST..... 23, 25, 26
OPERATION.....16	SLOPE GUIDE .....27
MAINTENANCE .....17	PARTS ORDERING/SERVICE .....BACK COVER

## WARRANTY

### ONE YEAR FULL WARRANTY

When operated and maintained according to the instructions supplied with it, if this Snowthrower fails due to a defect in material or workmanship within one year from the date of purchase, call 1-800-4-MY-HOME® to arrange for free repair (or replacement if repair proves impossible).

If this product is used for commercial or rental purposes, this warranty applies for only 90 days from the date of purchase.

This warranty gives you specific legal rights, and you may also have other rights which vary from state to state.

**Sears, Roebuck and Co., D817WA, Hoffman Estates, IL 60179**

## ACCESSORIES AND ATTACHMENTS

These and other accessories are recommended for use with your unit. Call 1-800-4-MY-HOME® to find out if they are available. If available, they may be purchased at most Craftsman outlets or by calling 1-800-4-MY-HOME®.

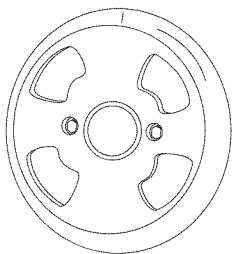
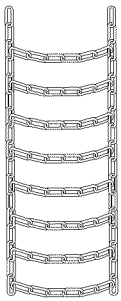
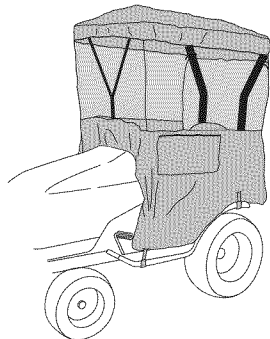
<p><b>WHEEL WEIGHT</b></p> 	<p><b>TIRE CHAINS</b></p> 	<p><b>SNOW CAB</b></p> 
--	---	--

<p>The model number and serial numbers will be found on a decal attached to the snow thrower.</p> <p>You should record both the serial number and the date of purchase and keep in a safe place for future reference.</p>	<table border="0" style="width: 100%;"> <tr> <td style="width: 60%;">MODEL NUMBER:</td> <td style="text-align: right;">486.248371</td> </tr> <tr> <td>SERIAL NUMBER:</td> <td style="text-align: right;">_____</td> </tr> <tr> <td>DATE OF PURCHASE:</td> <td style="text-align: right;">_____</td> </tr> </table>	MODEL NUMBER:	486.248371	SERIAL NUMBER:	_____	DATE OF PURCHASE:	_____
MODEL NUMBER:	486.248371						
SERIAL NUMBER:	_____						
DATE OF PURCHASE:	_____						





## SAFETY

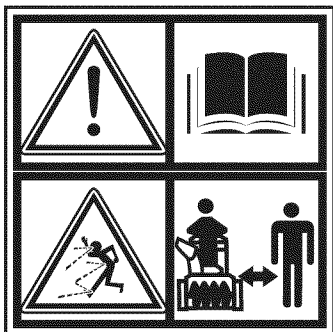

184045

Read and understand the operating instructions before using.

Keep the area of operation clear of all persons, especially small children and pets. Thoroughly inspect the area to be cleared and remove all door mats, sleds, boards, wires and other foreign objects. Use extreme caution when operating on or crossing gravel surfaces. Never direct discharge at bystanders or allow anyone in front of the snow thrower.



199682

Do not place hands near rotating parts. Keep clear of the discharge opening at all times.

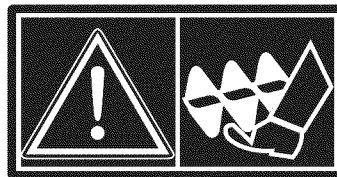

199683

Do not place feet near rotating parts.

- Never allow children to operate the equipment.
- Never allow adults to operate the equipment without proper instruction.
- Disengage all clutches and shift into neutral before starting engine.
- Do not operate equipment without wearing adequate winter outer garments.
- Wear substantial footwear which will protect feet and improve footing on slippery surfaces.
- Check fuel before starting the engine. Do not remove the fuel cap or fill the fuel tank while the engine is running or hot. Do not fill the fuel tank indoors. Gasoline is an extremely flammable fuel.
- Make sure the snow thrower height is adjusted to clear the type surface it will be used on.
- Do not use the snow thrower without wheel weights attached to the tractor.
- Never make any adjustments while the engine is running.
- Always wear safety glasses or eye shield during operation or while performing adjustment or repair.
- Do not place hands or feet near rotating parts. Keep clear of the discharge opening at all times.
- Do not carry passengers.
- After striking a foreign object, stop the engine, remove the wire from the spark plug and then thoroughly inspect the snow thrower for damage. Repair any damage before restarting and operating the snow thrower.
- If the snow thrower starts to vibrate abnormally, stop the engine immediately and check for the cause. Vibration is generally a warning of trouble.
- Stop the engine whenever you leave the operating position, before unclogging the snow thrower or making any adjustments or inspections.
- Take all possible precautions when leaving the unit unattended. Disengage the attachment clutch lever or switch, lower the snow thrower, shift into neutral, set the parking brake, stop the engine and remove the key.
- When cleaning, repairing or inspecting, make certain all moving parts have stopped. Disconnect the spark plug wire and keep it away from the plug to prevent accidental starting.
- Do not run engine indoors except when transporting the snow thrower in or out of the building. Open the outside doors. Exhaust fumes are dangerous.
- Do not clear snow across the face of slopes. Exercise extreme caution when changing direction on slopes. Do not attempt to clear steep slopes. Refer to the slope guide on page 35 of this manual.
- Never operate the snow thrower without guards, plates or other safety protection devices in place.
- Never operate the snow thrower near glass enclosures, automobiles, window wells, drop offs etc. without proper adjustment of the snow thrower discharge angle.
- Never run the snow thrower into snow at high speeds.
- Do not overload the snow thrower capacity by attempting to clear snow at too fast a rate.
- Never operate the snow thrower at high transport speed on slippery surfaces. Look behind and use care when backing up.
- Watch for traffic and stay alert when crossing or operating near roadways.
- Disengage power to the snow thrower when transporting or when not in use.
- Use only attachments and accessories approved by the manufacturer of the snow thrower (such as wheel weights, counter weights, cabs etc.)
- Never operate the snow thrower without good visibility.

# HARDWARE PACKAGE CONTENTS

SHOWN ACTUAL SIZE

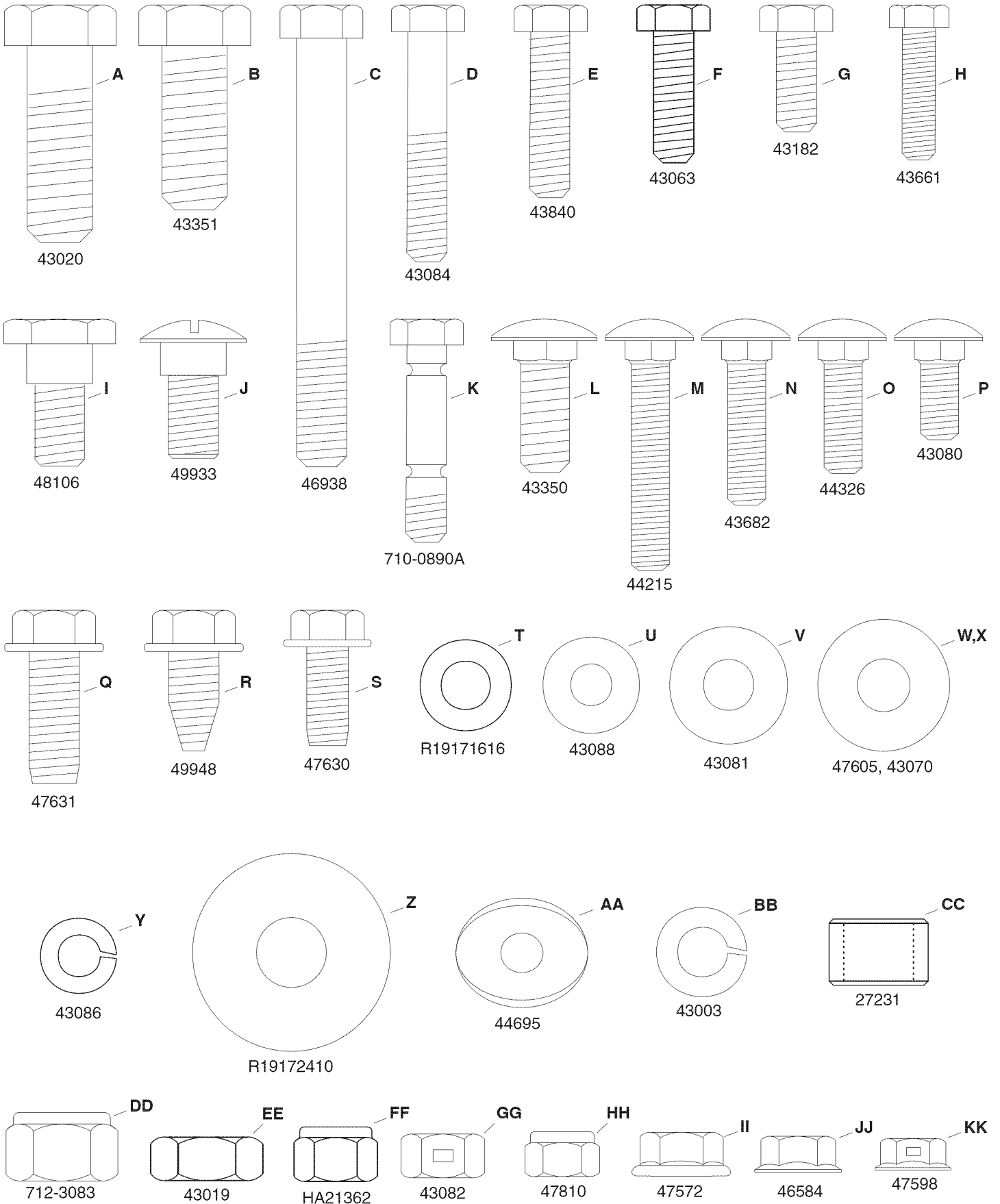

## NOT SHOWN ACTUAL SIZE

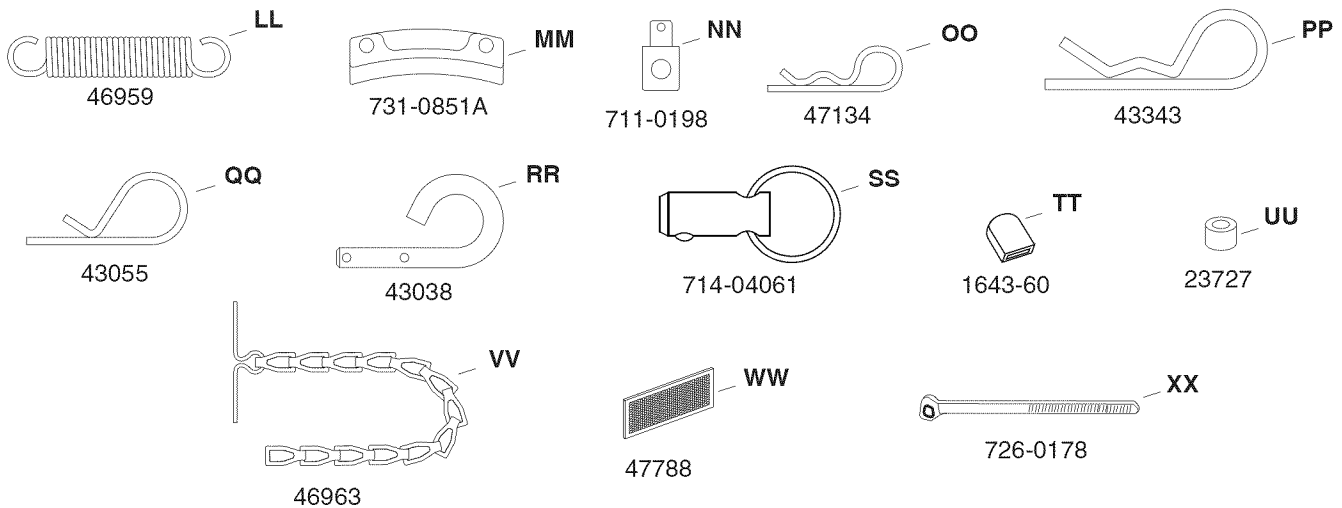

**IMPORTANT:** Not all items supplied in the hardware bag will be needed for your particular tractor. Unneeded items may be discarded after you have completed assembly and checked operation of unit. **DO NOT DISCARD** the two spare shear bolts (K) and 5/16" nylock nuts (HH). Refer to the Service and Adjustments section on page 18.

REF.	QTY.	DESCRIPTION	REF.	QTY.	DESCRIPTION
A	2	Hex Bolt, 1/2" x 1-1/2"	AA	2	Bowed Washer
B	2	Hex Bolt, 1/2" x 1-1/4"	BB	7	Lock Washer, 3/8"
C	1	Hex Bolt, 3/8" x 3-1/4"	CC	2	Spacer, 1/2"
D	2	Hex Bolt, 5/16" x 1-3/4"	DD	4	Nylock Nut, 1/2"
E	2	Hex Bolt, 5/16" x 1-1/4"	EE	4	Jam Nut, 1/2"
F	4	Hex Bolt, 5/16" x 1"	FF	6	Nylock Nut, 3/8"
G	8	Hex Bolt, 5/16" x 3/4"	GG	2	Hex Lock Nut, 3/8"
H	6	Hex Bolt, 1/4" x 1"	HH	21	Nylock Nut, 5/16" (2 spare parts)
I	4	Shoulder Bolt, Hex Head	II	10	Flanged Nut, 3/8"
J	2	Shoulder Bolt, Round Head	JJ	1	Flanged Nut, 5/16"
K	2	Shear Bolt (spare parts)	KK	6	Flanged Nut, 1/4"
L	6	Carriage Bolt, 3/8" x 1"	LL	1	Spring
M	2	Carriage Bolt, 5/16" x 1-3/4"	MM	3	Chute Keeper
N	2	Carriage Bolt, 5/16" x 1-1/4"	NN	1	Trunnion
O	4	Carriage Bolt, 5/16" x 1"	OO	4	Hairpin Cotter, 5/64"
P	2	Carriage Bolt, 5/16" x 3/4"	PP	4	Hairpin Cotter, 1/8"
Q	6	Hex Bolt, 3/8" x 1" (Thread Forming)	QQ	1	Hairpin Cotter, 3/32"
R	2	Hex Bolt, 3/8" x 3/4" (Thread Forming)	RR	2	Lock Pin
S	2	Hex Bolt, 5/16" x 3/4" (Thread Forming)	SS	2	Quick Release Pin
T	4	Washer, 1/2" x 1"	TT	1	Plastic Cap
U	7	Washer, 1/4"	UU	1	Spacer, 1/4"
V	22	Washer, 5/16" (Extra washers included)	VV	2	Chain, Tensioning
W	1	Washer, 3/8" (Thin)	WW	2	Tail Reflector
X	3	Washer, 3/8" Standard	XX	2	Nylon Tie
Y	2	Lock Washer, 5/16"			
Z	8	Washer, 1/2" x 1-1/2"			

# CARTON CONTENTS

- |  |                                  |
|--|----------------------------------|
| 1. Housing Assembly                              | 12. Hanger Bracket Assembly R.H. |
| 2. Lift Handle and Cable                         | 13. Hanger Bracket Assembly L.H. |
| 3. Chute Crank Rod Assembly                      | 14. Rear Frame Bracket L.H.      |
| 4. Support Tube, Crank Rod                       | 15. Rear Frame Bracket R.H.      |
| 5. V-Belt, Drive 52" (#41353)                    | 16. Front Frame Bracket L.H.     |
| 6. V-Belt, Drive 55" (#46989)                    | 17. Front Frame Bracket R.H.     |
| 7. Chute and Control Cable Assembly              | 18. Support Link (2)             |
| 8. Clutch Idler Assembly                         | 19. Support Tube (2)             |
| 9. Anti-rotation Bracket                         | 20. Side Plate L.H.              |
| 10. V-Belt, Auger (Attached to Housing Assembly) | 21. Side Plate R.H.              |
| 11. Frame Brace                                  |                                  |

ONLY ITEMS NEEDED FOR MODEL 247.\_\_\_\_ TRACTORS ARE SHOWN

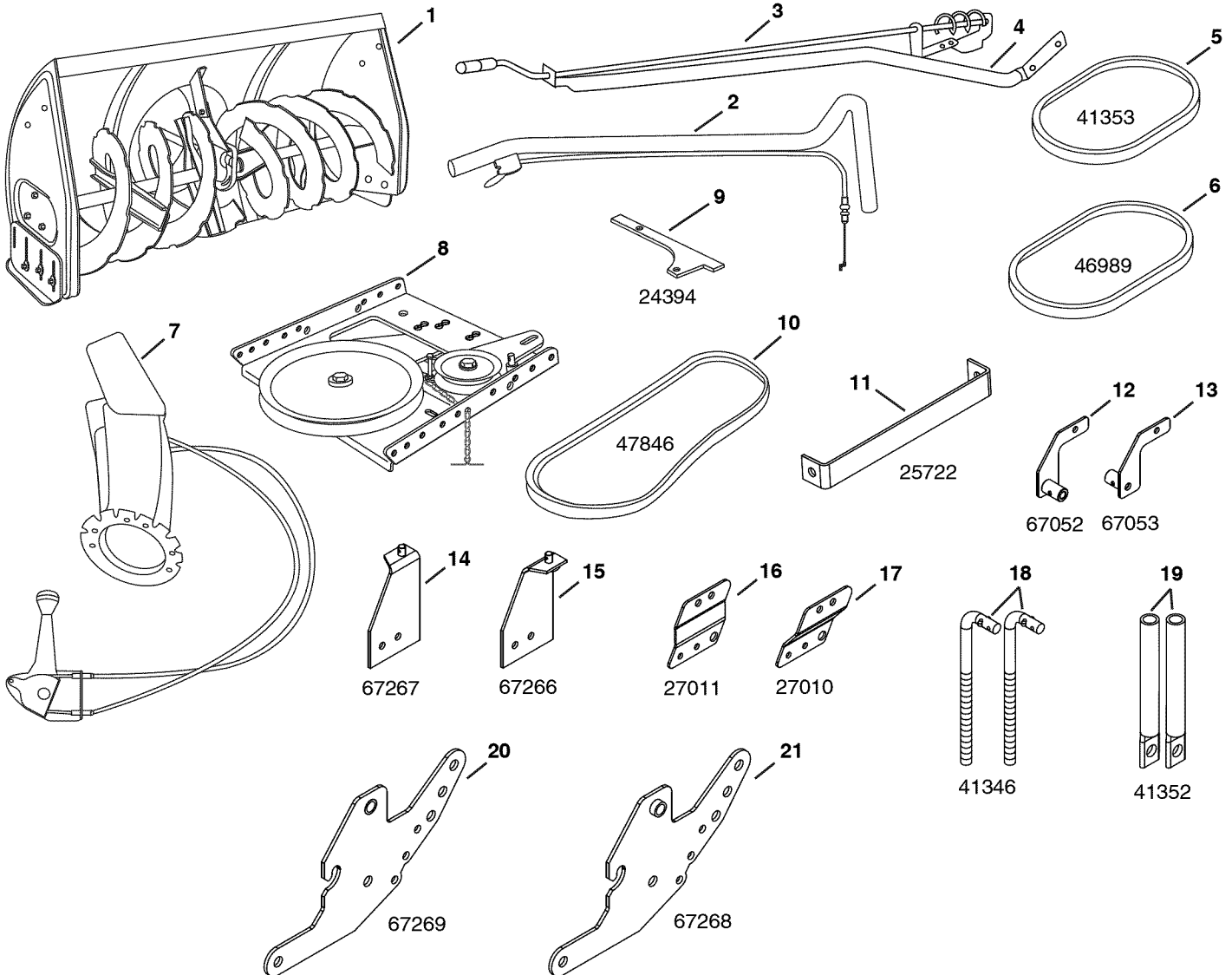

# ASSEMBLY

## LOCATE TRACTOR'S MODEL LABEL

Look under your tractor seat to locate the model number label shown below. This manual is for tractors with model numbers that start with 247 as shown below.



**CAUTION:** Before starting to assemble the snow thrower, remove the spark plug wire(s), set the parking brake and remove the key from the tractor ignition.

## 247 MODEL TRACTORS

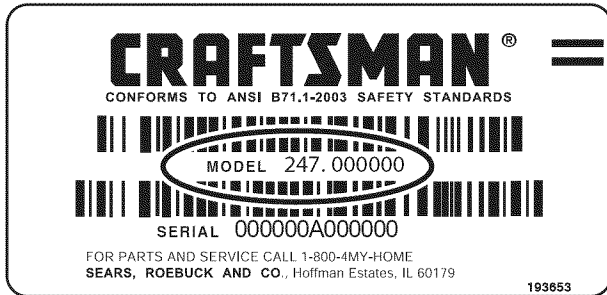

**IMPORTANT:** If your model number starts with 917, use the owner's manual and the parts that are contained in the other parts bag.

## TRACTOR PREPARATION

Before performing these instructions, refer to the Service and Adjustments section of your tractor owner's manual for specific safety instructions.

- Allow engine, muffler and exhaust deflector to cool before beginning.
- Remove any front or rear attachment which is mounted to your tractor.
- Remove the mower deck. Refer to your tractor owner's manual for removal instructions. Mark all loose parts and save for reassembly.
- Remove the tractor hood. Refer to your tractor owner's manual for removal instructions.

## TOOLS REQUIRED FOR ASSEMBLY

- (2) 7/16" Wrenches
- (2) 1/2" Wrenches
- (2) 9/16" Wrenches
- (2) 3/4" Wrenches
- (1) Knife

## ADDITIONAL ITEMS REQUIRED

General Purpose Grease

**IMPORTANT:** Right hand (R.H.) and left hand (L.H.) side of the tractor are determined from the operators position while seated on the tractor.

## REMOVAL OF PARTS FROM CARTON

- Remove all loose parts, parts bags and hardware bags from the carton. Lay out and identify parts and hardware using the illustrations on pages 4, 5 and 6. The parts bag labeled for 917 model tractors will not be needed.

**IMPORTANT:** Not all items supplied in the hardware bag will be needed for your particular tractor. Unneeded items may be discarded after you have completed assembly and checked operation of unit. **DO NOT DISCARD** the two spare shear bolts (K) and 5/16" nylock nuts (HH). Refer to the Service and Adjustments section on page 18.

**STEP 1: (SEE FIGURE 1)**

- Assemble a shoulder bolt and a 3/8" nylock nut to the holes shown on each side of the tractor frame.

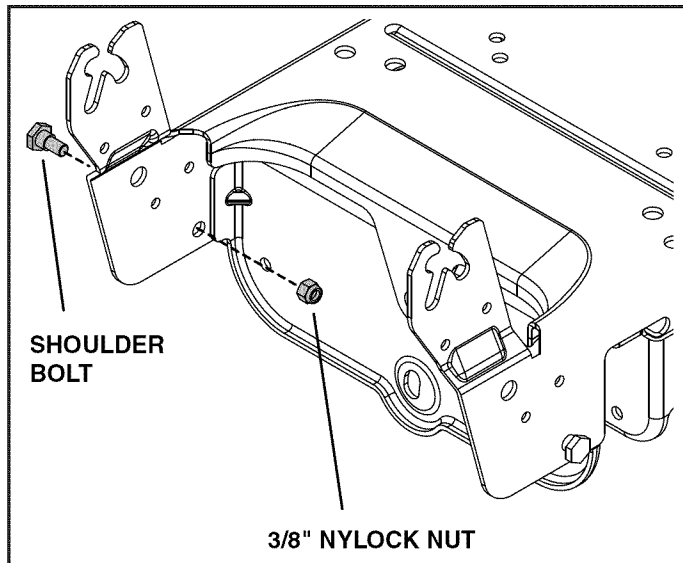

**FIGURE 1**

**STEP 2: (SEE FIGURE 2)**

- Place a front mount plate onto each shoulder bolt and install two quick release pins as shown.

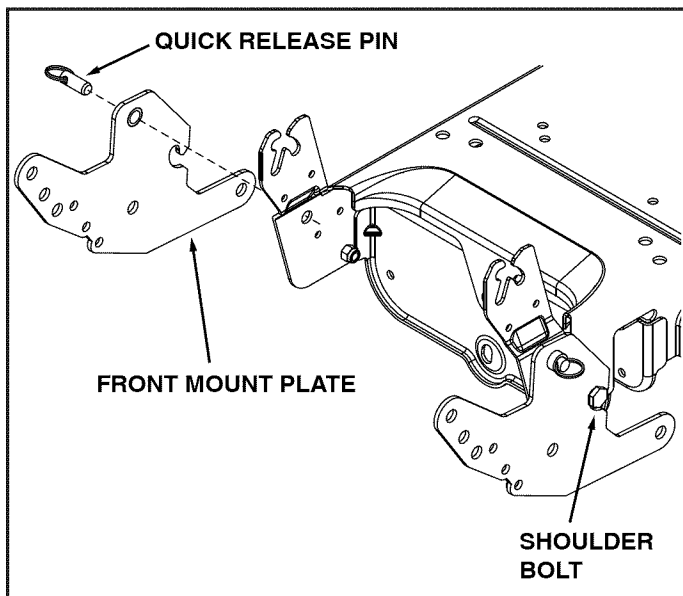

**FIGURE 2**

**STEP 3: (SEE FIGURE 3)**

- Attach the frame brace between the front mount plates using two 1/2" x 1-1/4" hex bolts, 1/2" x 1-1/2" washers and 1/2" nylock nuts.

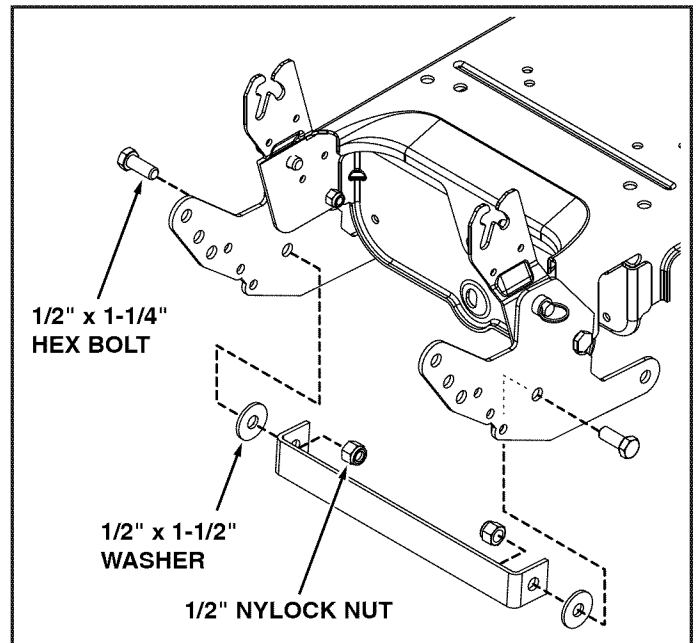

**FIGURE 3**

**STEP 4: (SEE FIGURE 4)**

- Measure from the center of the three holes indicated in figure 4 to select the hole that is approximately 10" above the ground in both front mount plates.
- Install a shoulder bolt and 3/8" nylock nut in the selected hole in each front mount plate.

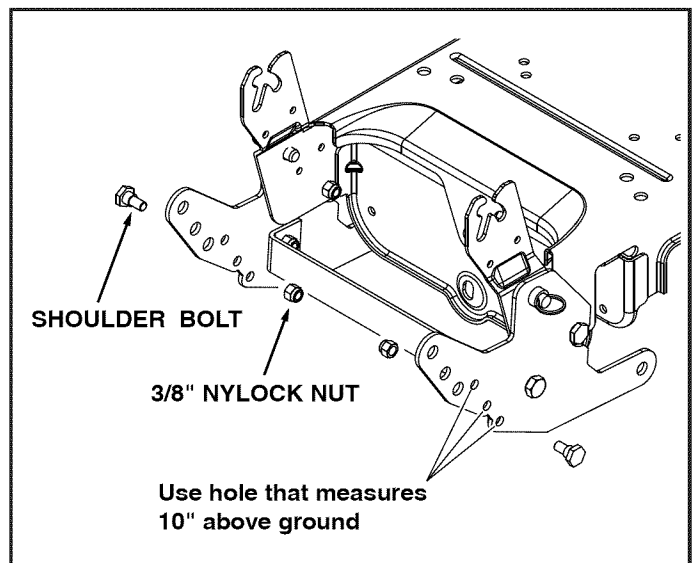

**FIGURE 4**

### STEP 5: (SEE FIGURE 5)

- Remove the thread forming bolt from the hole in the footrest bracket on the left side of the tractor frame.
- Attach the L.H. hanger bracket to the empty hole using a 5/16" x 1" hex bolt, a 5/16" lock washer, and a 5/16" flat washer. Place the flat washer between the hanger bracket and the footrest bracket.
- Repeat on the right side of the tractor frame using the R.H. hanger bracket.

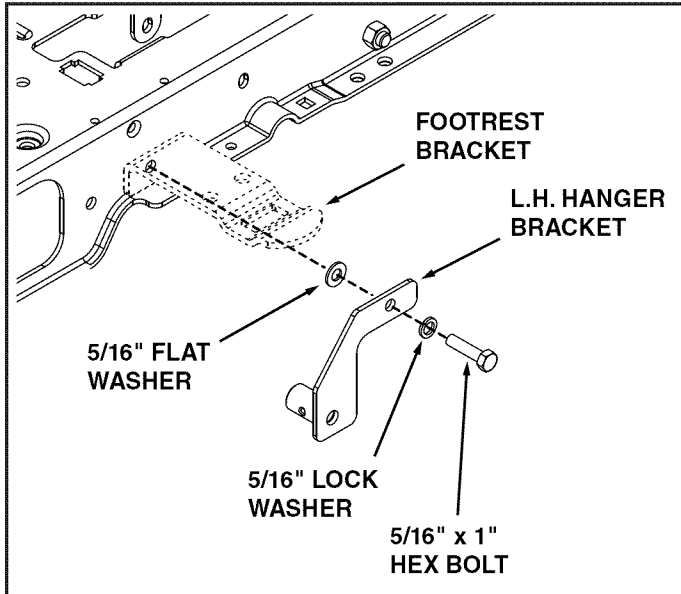

FIGURE 5

### STEP 6: (SEE FIGURE 6)

- Turn the clutch idler assembly upside down.
- Attach the spring from the parts bag to the bottom of the upper idler arm. Hook the spring onto the bolt that extends through the nut on the bottom of the upper idler arm and then install a 3/8" hex lock nut onto the bolt. Leave enough space for the spring to pivot.

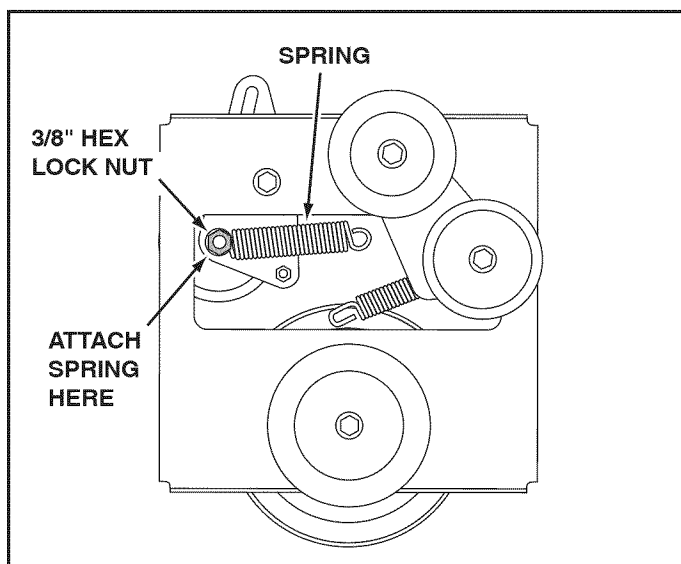

FIGURE 6

### STEP 7 (SEE FIGURE 7)

- Insert tensioning chains through the holes shown and attach to the springs on the upper and lower idler arms.
- Attach a 3/32" hairpin cotter to the chain attached to the upper idler arm, placing it in the third link from the spring.

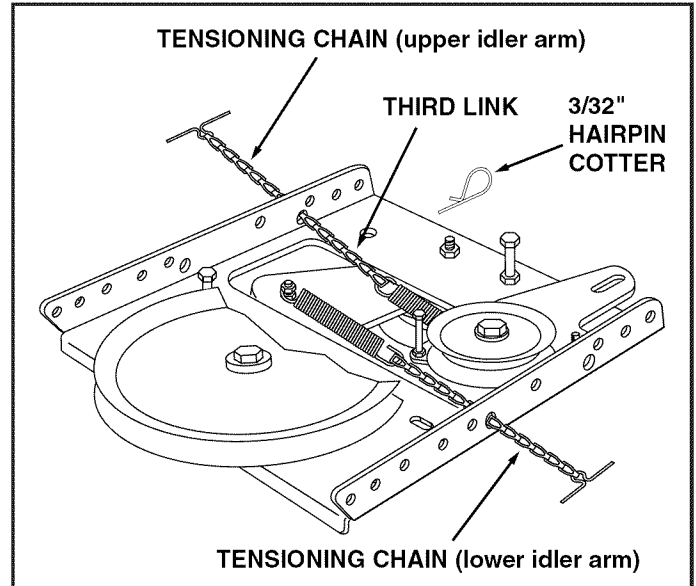

FIGURE 7

### STEP 8: (SEE FIGURE 8)

- Refer back to step 4. If you used the top hole indicated in step 4, use hole A in this step. If you used one of the two lower holes, use hole B in this step.
- Attach the R.H. and L.H. rear frame brackets on the **inside** to either hole A or B using one 5/16" x 3/4" hex bolt and 5/16" nylock nut for each bracket. **Do not tighten yet.**
- Assemble the R.H. and L.H. front frame brackets on the **outside** using two 5/16" x 3/4" hex bolts and 5/16" nylock nuts for each bracket.

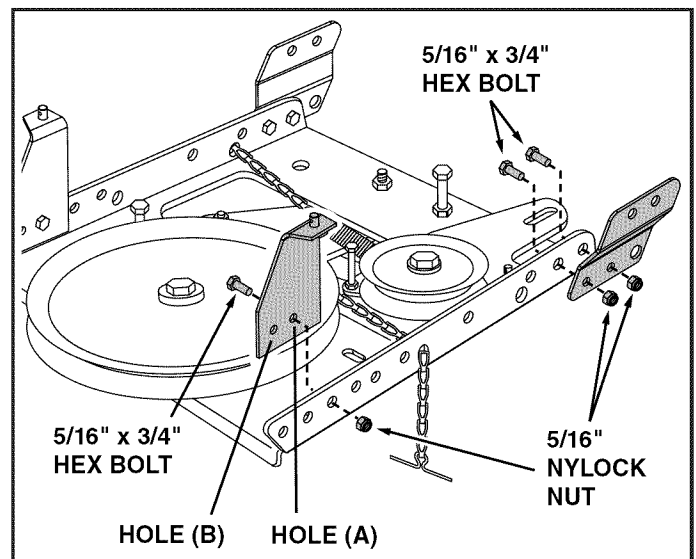

FIGURE 8

### STEP 9: (SEE FIGURE 9)

- Assemble the two support tubes to the inside of each front frame bracket using a 1/2" x 1-1/2" hex bolt, a 1/2" spacer and a 1/2" nylock nut for each bracket. **Do not tighten yet.**

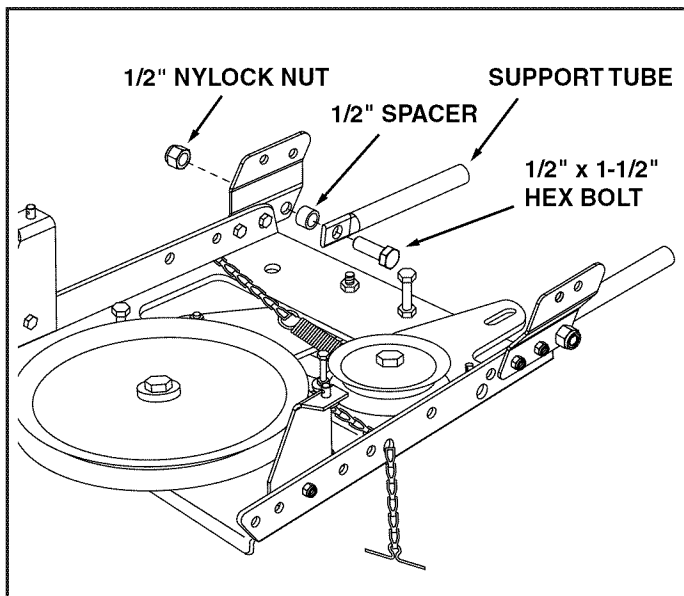

FIGURE 9

### STEP 10: (SEE FIGURE 10)

- Three drive belts are supplied with the snow thrower. Select one of the two shorter belts. If you used hole A in step 8, use the 52" drive belt (#41353) belt. If you used hole B, use the 55" drive belt (#46989).
- Slightly loosen the hex bolt next to the flat idler pulley. Install the drive belt between the hex bolt and the flat idler pulley with the flat side of the belt against the pulley. **Retighten** the hex bolt.
- Loop the belt around the large v-pulley, placing it between the pulley and the hex bolt next to the pulley.

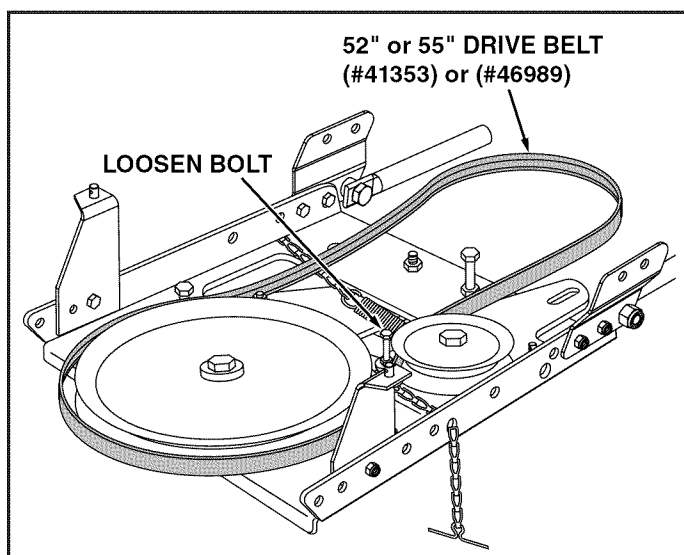

FIGURE 10

### STEP 11 (SEE FIGURE 11)

- Assemble two 1/2" jam nuts all the way onto the threads of each support link.

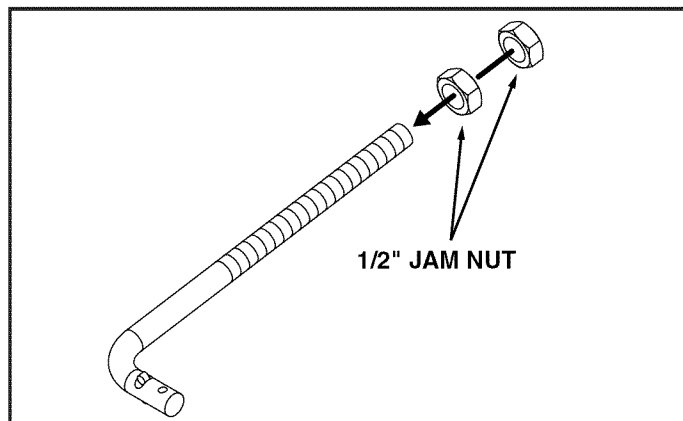

FIGURE 11

### STEP 12: (SEE FIGURE 12)

- Attach the front frame brackets to the two hanger brackets on the tractor frame using two pivot lock pins and 1/8" hairpin cotters.
- Attach the rear frame brackets to the bottom of the tractor frame using two small 5/64" hairpin cotters.

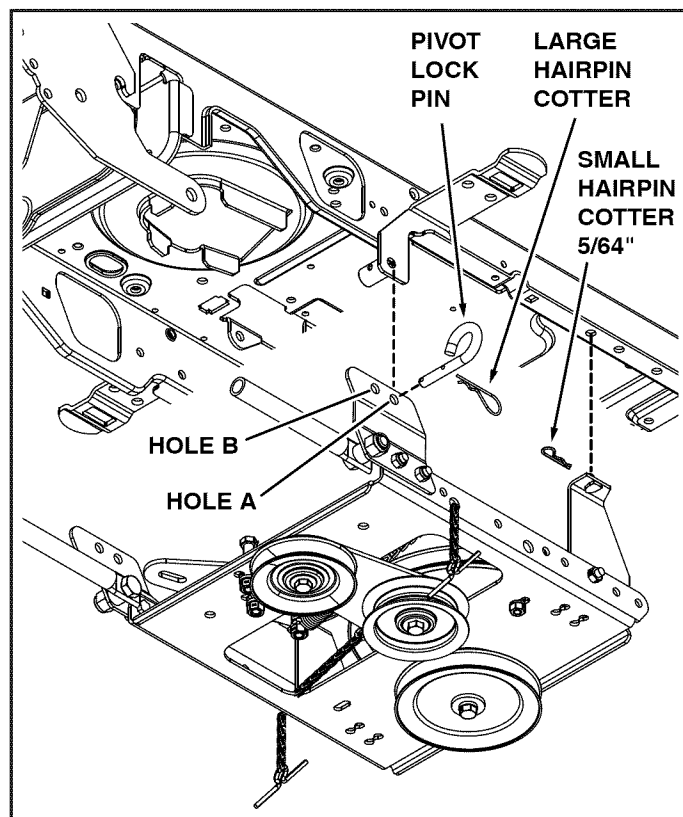
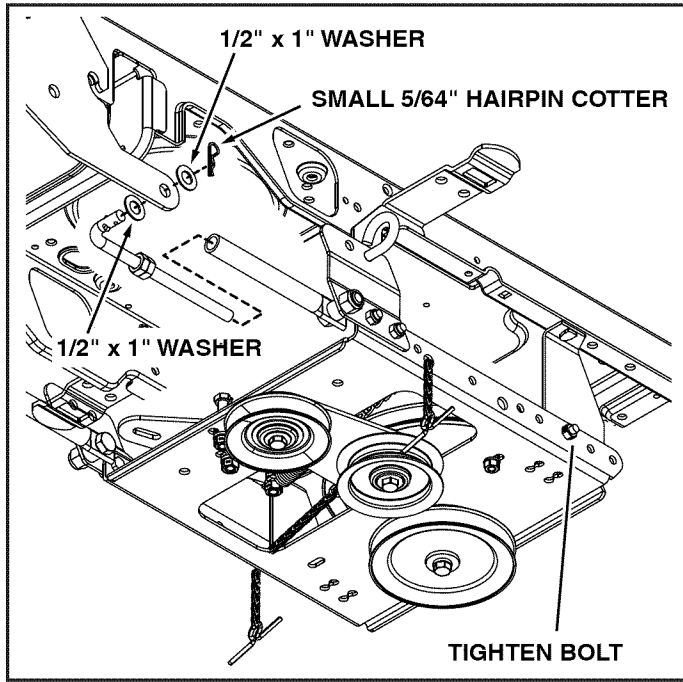

FIGURE 12

**STEP 13 (SEE FIGURE 13)**

- Assemble a 1/2" x 1" washer onto the bent end of a support link and then insert the threaded end into a support tube and the bent end into the rear hole in a front mounting plate. Assemble another 1/2" x 1" washer onto the end of the link and secure it with a small 5/64" hairpin cotter. Repeat for the other support link.
- **Tighten** the bolt and nut in each rear frame bracket.
- **Tighten** the bolt and nut in each support link.
- **Tighten** the jam nuts so that all looseness is eliminated from the support links and support tubes.



**FIGURE 13**

**STEP 14: (SEE FIGURE 14)**

- Remove the belt guard for the PTO pulley on the tractor. Refer to "Cutting Deck Removal" in the SERVICE AND MAINTENANCE section of your tractor Operator's Manual.
- Install the drive belt onto the tractor's PTO pulley. You may need to temporarily lift the belt from the large pulley on the clutch idler assembly.
- Reinstall the belt guard for the tractor's PTO pulley. Be sure the belt guard is installed in the notch on the side of the tractor's electric clutch.
- Place tension on the belt by pulling the left side tensioning chain out as far as the 3/32" hairpin cotter will allow. Secure the chain in this position by inserting a 1/8" hairpin cotter through the chain.



**DO NOT** start the engine until the PTO pulley belt guard has been reinstalled. The tractor's electric clutch could be damaged.

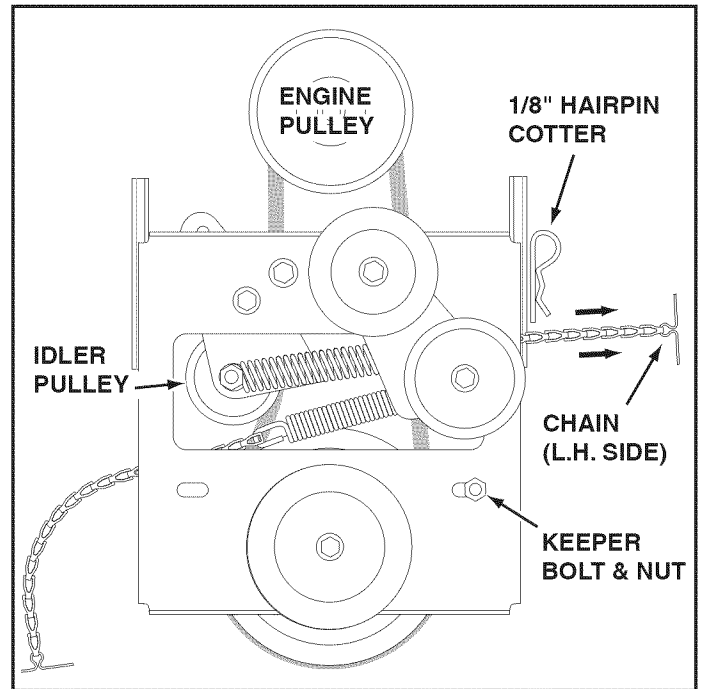

**FIGURE 14**

**VIEWED FROM UNDERNEATH**

## ASSEMBLY OF THE SNOW THROWER

### STEP 15: (SEE FIGURE 15)

- Place the lift handle into the lift bracket on the right side of the snow thrower. Fasten the handle to the bracket using two 5/16" x 1-3/4" hex bolts and 5/16" Nylock nuts.

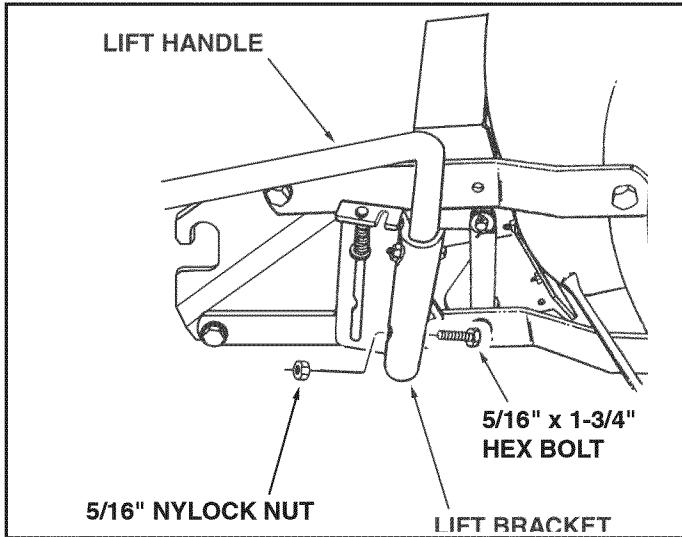

FIGURE 15 RIGHT SIDE VIEW

**NOTE:** Be sure the lift release cable's plastic covering stays inserted into the trigger assembly for the next step.

### STEP 16 (SEE FIGURE 16)

- Push the lift handle down into the locked position. Insert the end of the cable wire into the hole in the lift rod. Place the threaded fitting into the slot in the lift bracket, with one hex nut above and one hex nut and the lock washer below the slot. Tighten the nuts, adjusting them to eliminate slack in the cable wire. Refer also to the Service and Adjustments section on page 18 in this manual.

**HINT:** For easier assembly of the lift release cable, tilt the snow thrower forward onto the spiral auger.

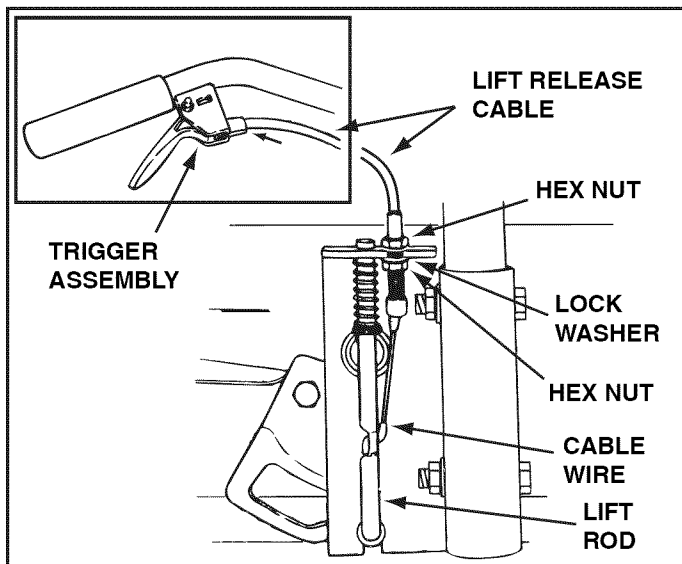

FIGURE 16 RIGHT SIDE VIEW

### STEP 17: (SEE FIGURE 17)

- Tilt the snow thrower back down to the ground.
- Remove the nylon tie which fastens the auger drive belt to the discharge housing, leaving the belt assembled around the pulleys.
- Remove the nylon tie which fastens the chute crank rod to the crank rod support tube.
- Assemble the crank rod support tube to the bracket on the left side of the discharge housing using two 5/16" x 1-1/4" carriage bolts, and 5/16" Nylock nuts.

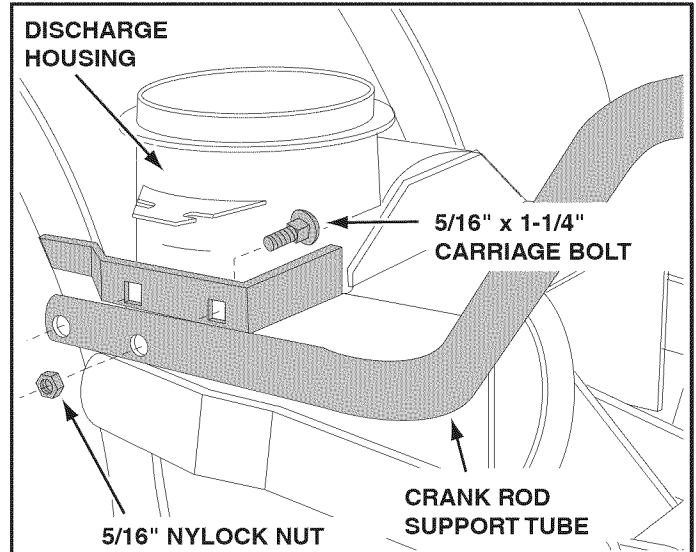

FIGURE 17 LEFT SIDE VIEW

### STEP 18: (SEE FIGURE 18)

- Attach the chute tilt control assembly to the top side of the crank support tube using two 5/16" x 1-3/4" carriage bolts, bowed washers and 5/16" Nylock nuts.

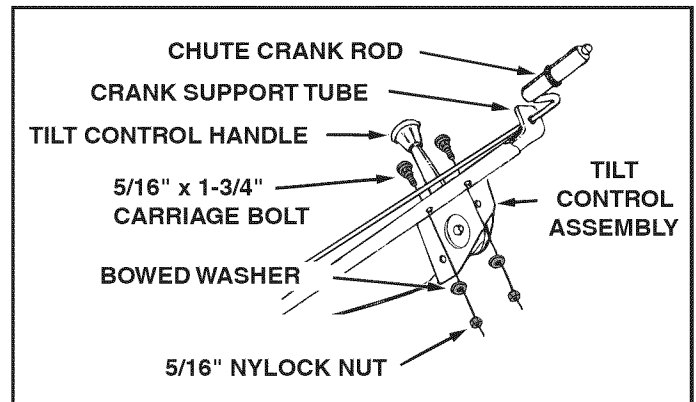

FIGURE 18 LEFT SIDE VIEW

**STEP 19: (SEE FIGURE 19)**

- Attach the chute crank rod assembly brackets to the plastic bracket on the left side of the discharge housing. Align the chute crank bracket beneath the rod support bracket and assemble both to the plastic bracket using two 5/16" x 1" carriage bolts, 5/16" washers and 5/16" Nylock nuts. **Do not tighten yet.**

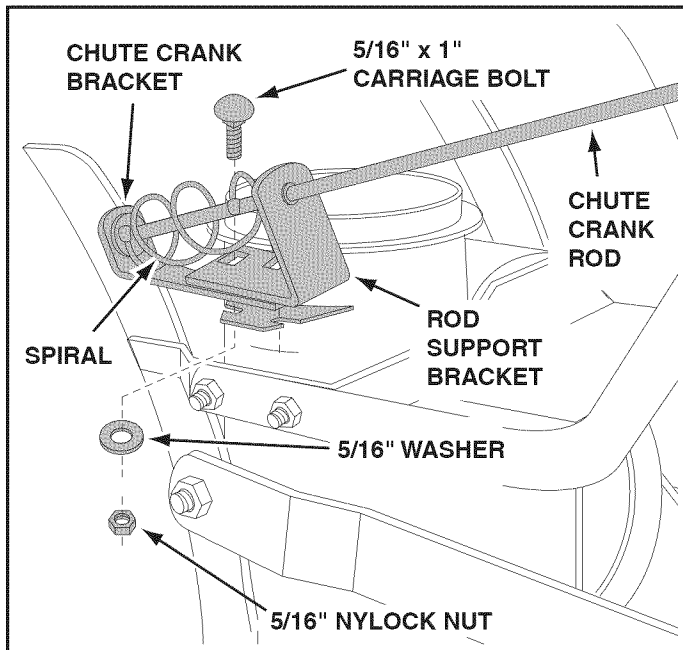

FIGURE 19

LEFT SIDE VIEW

**STEP 20: (SEE FIGURE 20)**

- Coat the top of the ring around the discharge opening with general purpose grease.
- Place the discharge chute (facing forward) onto the ring. Place the anti-rotation bracket on top of the chute flange, aligning it with the holes on the right hand side of the flange. Attach the three chute keepers (right side up as shown) to the bottom of the flange using six 1/4" x 1" hex bolts, 1/4" flat washers and 1/4" flanged lock nuts. **Tighten carefully** so that the nuts are snug but do not dig into the plastic chute keepers.
- Place the plastic cap onto the short end of the anti-rotation bracket.
- Position the crank rod spiral (see figure 19) so that it does not rub against the bottoms of the notches in the chute flange. **Tighten** the nuts.
- Check if the crank rod rotates the chute freely. If not, loosen by 1/4 turn each of the six hex bolts holding the chute keepers to the chute flange.
- Secure the control cables to the crank rod support tube using a nylon tie.

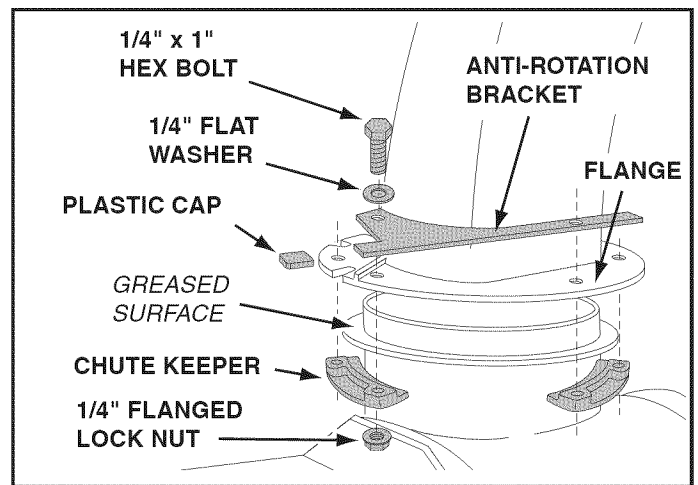

FIGURE 20

RIGHT SIDE VIEW

**STEP 21: (SEE FIGURE 21)**

- If the snow thrower will not lower approximately 1" below grade after it is attached to the tractor, remove the stop bolts from each side of the snow thrower frame.

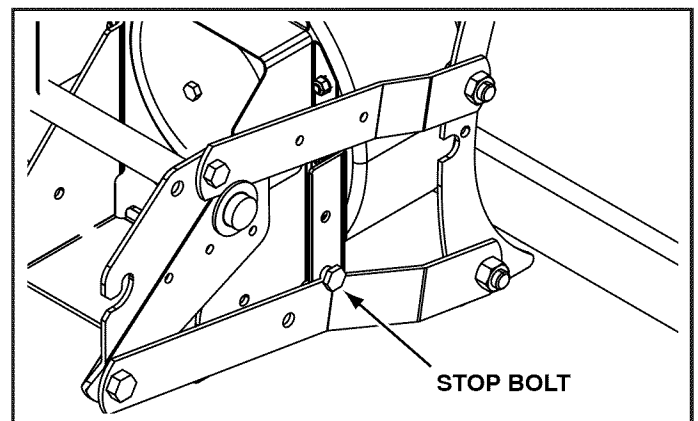

FIGURE 21

RIGHT SIDE VIEW

## ATTACHING SNOW THROWER TO TRACTOR

### STEP 22: (SEE FIGURE 22)

- Place the snow thrower on a flat, level surface.
- Extend the auger belt out behind the snow thrower, leaving the belt assembled to the snow thrower pulleys.
- Roll the tractor up behind the snow thrower, centering it between the snow thrower's mounting plates.
- Remove the Attachment Pin from the snow thrower.
- Raise the rear of the snow thrower by lifting up on the lift handle until the notches in the mounting plates align with the shoulder bolts in the tractor's side plates. Guide the bolts into the notches.
- Delay installing the attachment pin until you have assembled the belt as instructed in steps 23 and 24.

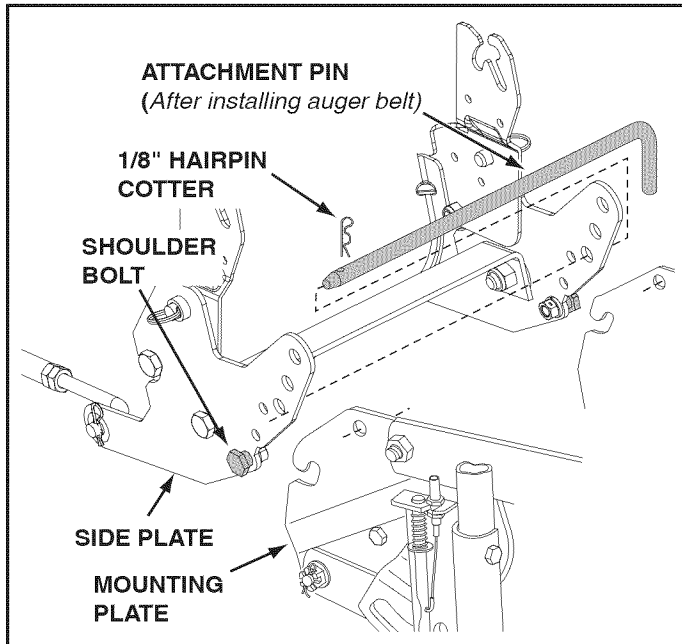

FIGURE 22 RIGHT SIDE VIEW

### STEP 23: (SEE FIGURE 23)

- The auger belt comes pre-assembled to the pulleys on the snow thrower housing. Make sure the belt passes over the top of the auger pulley and then twists 1/4 turn to pass underneath each side idler pulley. The "V" side of the belt must mate with the grooves of the pulleys.

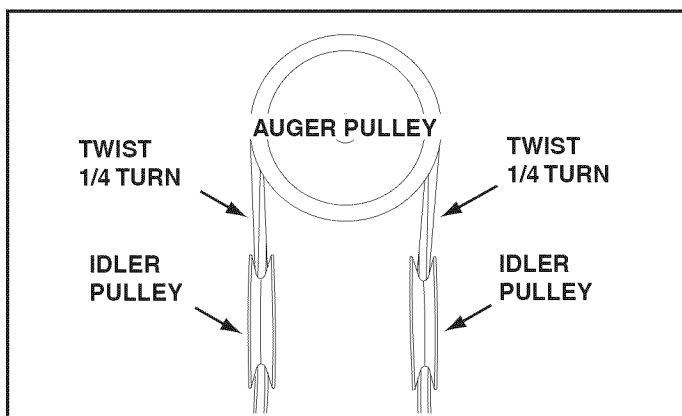

FIGURE 23

## INSTALLING THE AUGER BELT

### STEP 24: (SEE FIGURE 24)

- Push the lift handle down to increase slack in the belt (attachment pin must first be removed).
- Swing the idler arm over to the side.
- Place the auger belt around the rear pulley and between the two idler arm pulleys. The "V" side of the belt must be seated in the grooves of the V-pulleys.

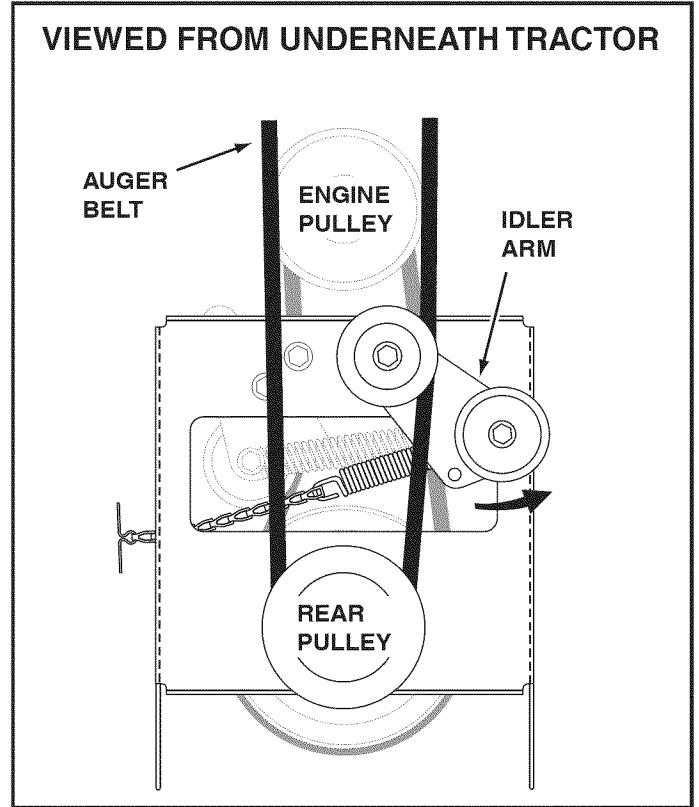
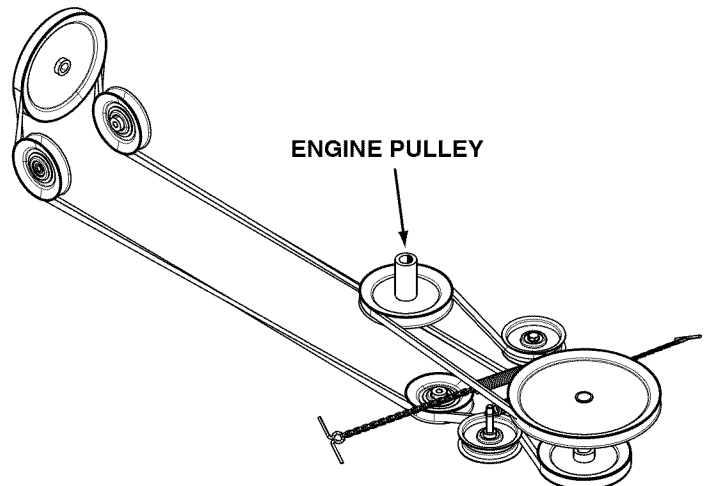

FIGURE 24 VIEWED FROM UNDERNEATH

## BELT ROUTING DIAGRAM



## INSTALLING THE ATTACHMENT PIN

### STEP 25: (REFER BACK TO FIGURE 22 ON PAGE 14)

- Lift the front of the snow blower to align the holes in the mounting plates and the side plates. From the left side of the tractor insert the attachment pin through the holes. Secure it with by reinstalling the 1/8" hairpin cotter.

## SETTING THE AUGER BELT TENSION

### STEP 26: (SEE FIGURE 25)

- Pull the tensioning chain until the end of the spring is pulled through the hole in the side of the Clutch/Idler assembly. Install a 1/8" hairpin cotter through the end of the spring, securing it on the outside of the Clutch/Idler assembly.

**IMPORTANT:** For correct belt tension, the 1/8" hairpin cotter must attach to the end of the spring, not to the chain.

**NOTE;** To prevent the chain from dragging on the ground, loop the end of the chain through the pivot lock pin.

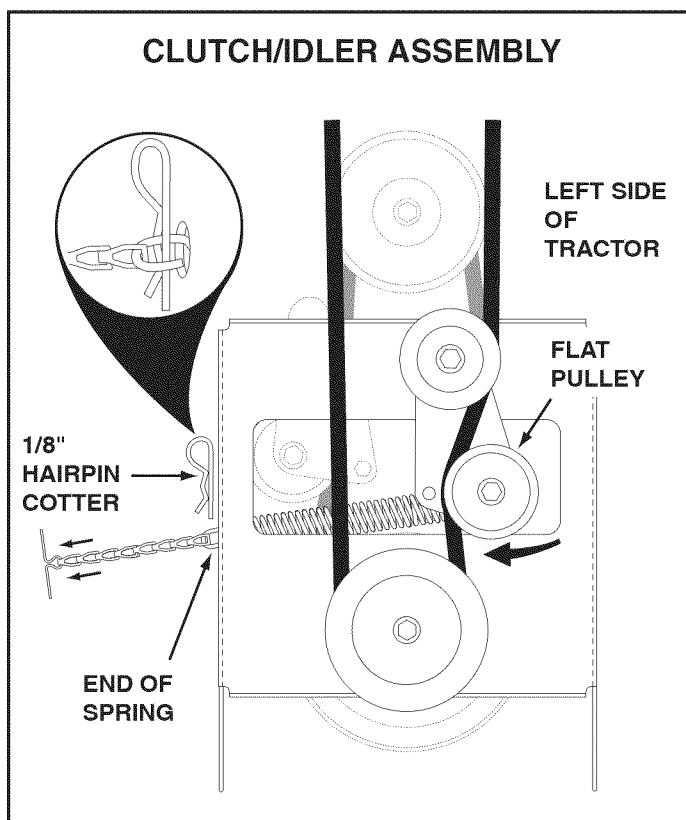

FIGURE 25

VIEWED FROM UNDERNEATH

## ATTACH REFLECTORS TO REAR FENDER

### STEP 27: (SEE FIGURE 26)

- If your tractor is not equipped with rear reflectors, assemble the supplied rear reflectors to the rear fender. Place the reflectors as close to the bottom of the fender and as far apart as the shape of the fender will allow.

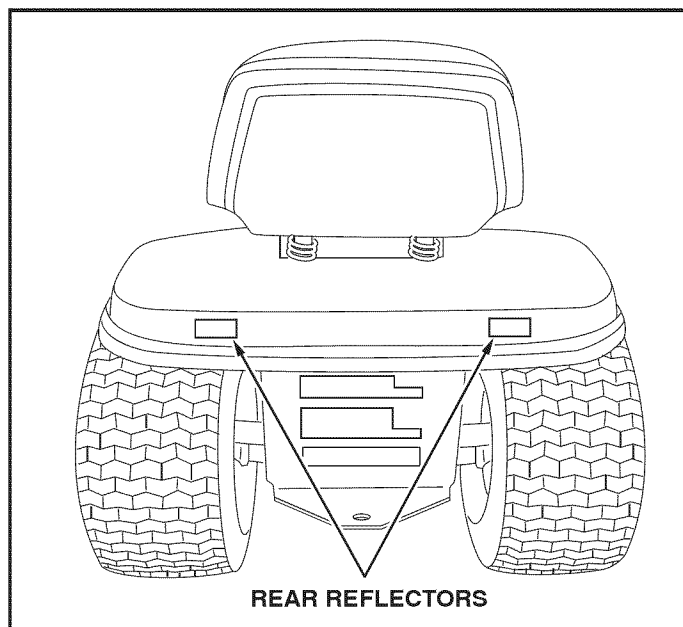

FIGURE 26

## CHECKLIST

**Before you operate your snow thrower, please review the following checklist to help ensure that you will obtain the best performance from your snow thrower.**

- Make sure all assembly instructions have been completed with all bolts and nuts properly tightened.
- Make sure the correct drive belt was installed.
- Make sure the drive belt and auger belt are routed properly around pulleys and inside all belt keepers.
- Check discharge chute for proper rotation.
- Check operation of tilt control for upper chute.
- Verify that the lift handle will lock into and release from the raised transport position. (Refer to the Service and Adjustments section.)
- Check skid shoe adjustment. (Refer to the Service and Adjustments section.)

**The following additional items are available from Sears to help enhance the performance of your snow thrower. See Accessories and Attachments on page 2.**

- Tire chains which can be installed to improve traction.
- Rear wheel weights which can be installed in addition to the rear weight tray to improve traction.
- Snow Cab which can be installed to help protect against wind and blowing snow.

# OPERATION

## KNOW YOUR SNOW THROWER

Read this owner's manual and safety rules before operating your snow thrower.

Compare the illustration below with your snow thrower to familiarize yourself with the various controls and their locations.

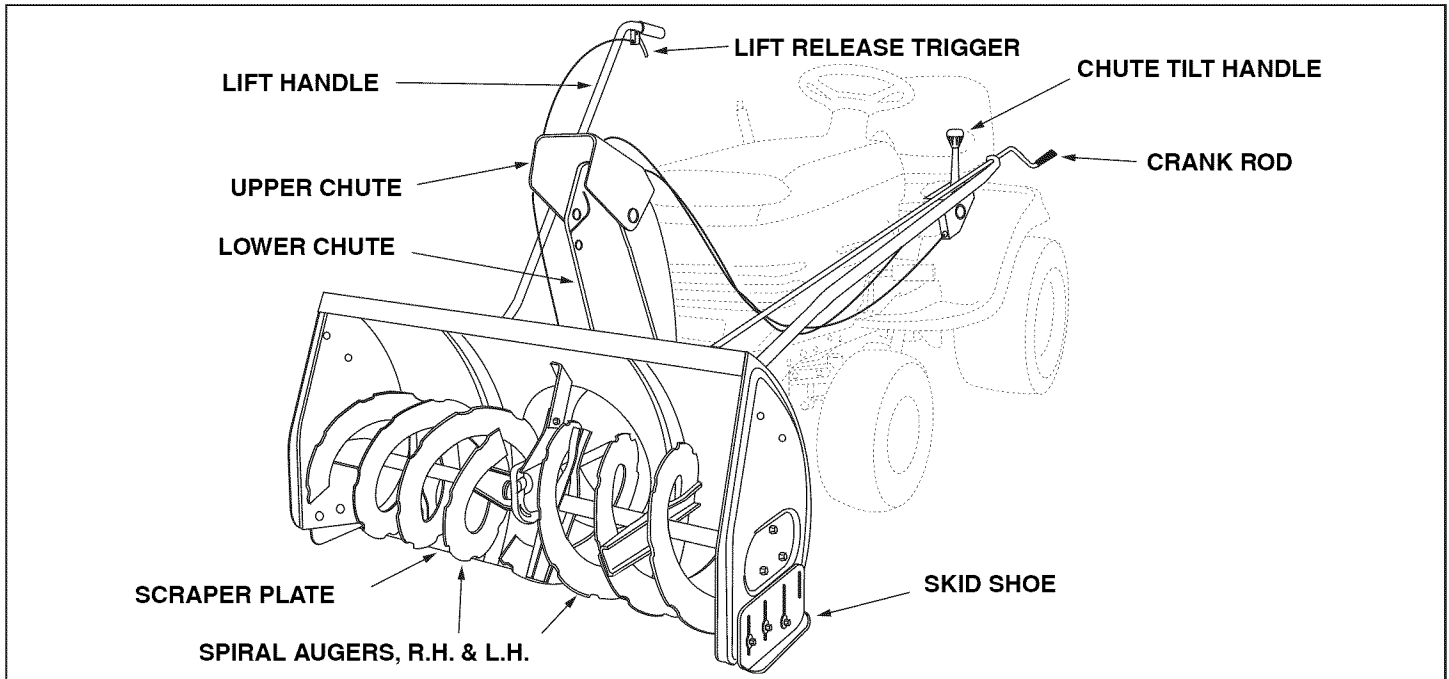

**CHUTE TILT HANDLE** Pivots the Upper Chute up or down to control the angle and distance of discharge.

**CRANK ROD** Rotates the Lower and Upper Chutes to control the direction of discharge.

**LIFT HANDLE** Used to lift or lower the snow thrower to transport or operating position.

**LIFT RELEASE TRIGGER** Releases the lock which holds the snow thrower in the transport position

**UPPER AND LOWER DISCHARGE CHUTE** Controls direction and height of snow discharge.

**SCRAPER PLATE** Replaceable plate that absorbs wear and impact from contact with ground.

**SKID SHOE** Controls amount of clearance between the scraper plate and the ground.

**SPIRAL AUGER, R.H. & L.H.** Feed snow to the impeller fan at the center of the housing.

## BEFORE STARTING

- Use the end of assembly checklist to verify that all instructions have been properly completed.
- Make sure the skid shoes are adjusted to maintain adequate ground clearance between the snow thrower and the type of surface to be cleared. (Refer to the Service and Adjustments section.)
- Make sure the tractor engine has the correct oil for winter operation (SAE 5W-30). Refer to tractor owner's manual.

## HOW TO START YOUR SNOW THROWER

- The tractor should be sitting with the engine running at full throttle. Move the attachment clutch to the engaged position, starting the snow thrower before the tractor clutch is engaged.

## HOW TO STOP YOUR SNOW THROWER

- To stop the snow thrower, disengage the tractor's attachment clutch lever for manual clutches or the clutch switch for electric clutches. Refer to your tractor owner's manual.

## HOW TO USE YOUR SNOW THROWER



**CAUTION:** Never direct discharge towards bystanders or windows. Do not allow anyone in front of unit.

## CONTROLLING SNOW DISCHARGE

- To control the direction snow is thrown, the discharge chute has 180 degrees of rotation. Turn the crank rod clockwise to rotate the chute to the right. Turn the crank rod counterclockwise to rotate the chute to the left.
- To control the distance snow is thrown, the upper section of the discharge chute pivots up and down. Push forward on the chute tilt handle to pivot the chute down, decreasing the distance snow is thrown. Pull back on the handle to pivot the chute up, increasing the distance snow is thrown.

**RAISING AND LOWERING**

- To raise, push down on the lift handle until the snow thrower locks in the raised transport position.
- To lower, push down slightly on the lift handle and pull the trigger. With the trigger pulled, slowly lower the snow thrower until it reaches the ground.



**CAUTION:** Do not operate the snow thrower without wheel weights attached to the tractor to provide extra traction and stability.

**REMOVING SNOW**

Snow removal conditions vary greatly from light fluffy snowfall to wet heavy snow. Operating instructions must be flexible to fit the conditions encountered. The operator must adapt the lawn tractor and snow thrower to depth of snow, wind direction, temperature and surface conditions.

- Before beginning operation, thoroughly inspect the area of operation and remove all door mats, sleds, boards, wires and other foreign objects.
- The spiral auger speed is directly related to engine speed. For maximum snow removal and discharge, maintain high engine r.p.m. (full throttle). It is advisable to operate the lawn tractor at a slow ground speed (1st gear) for safe and efficient snow removal.
- In deep, drifted or banked snow it will be necessary to use full throttle and a slow ground speed (1st gear). Drive forward into the snow, depress the tractor's clutch-brake pedal and allow the spiral auger to clear the snow. Repeat this method until a path is cleared. On the second pass, overlap the first enough to allow the snow thrower to handle the snow without repeated stopping and starting of forward motion.

- In extremely deep snow, raise the snow thrower from the ground to remove the top layer and drive forward only until the tractor's front tires reach the uncleared bottom layer of snow. Depress the tractor's clutch-brake pedal and allow the spiral auger to clear the snow. Reverse the tractor and lower the snow thrower to the ground. Drive the tractor forward until the snow again becomes too deep. Repeating this process into and out of drifts will eventually clear even the deepest of snow piles.
- If the snow thrower becomes clogged with snow or jammed with a foreign object, disengage the snow thrower immediately and shut off the tractor engine. Unclog the snow thrower before resuming operation.



**DANGER:** Shut off engine and disengage snow thrower before unclogging discharge chute. Unclog using a wooden stick, not your hands.

**OPERATING TIPS**

- Discharge snow down wind whenever possible.
- To help prevent snow from sticking to the snow thrower, allow the snow thrower to reach outdoor temperature before using it. A light coat of wax may also be applied to the inside surface of the snow thrower housing and discharge chute.
- Use tire chains to improve traction.
- Use rear wheel weights to improve traction.
- Before the first snowfall, remove all stones, sticks and other objects which could become hidden by the snow. Permanent obstacles should be marked for visibility.
- Overlap each pass slightly to assure complete snow removal.

**MAINTENANCE**

**CUSTOMER RESPONSIBILITIES**

- Read and follow the maintenance schedule and the maintenance procedures listed in this section.

MAINTENANCE SCHEDULE Fill in dates as you complete regular service.	Service Dates											
	Before each use	After each use	Every season	Before storage								
Check for loose fasteners	X											
Check scraper and shoes for wear	X			X								
Cleaning				X								
Lubrication Section			X									

**LUBRICATION**

- Oil all pivot points on the snow thrower.
- Oil the pivot points of the two idler arms on the clutch/idler assembly.
- Apply penetrating oil to the control cables of the discharge chute.
- Apply a good grade of spray lubricant to the trigger assembly and the chute tilt control assembly.

**CHECK SCRAPER AND SHOES FOR WEAR**

(Refer to figures 27 and 28 on page 18.)

- The scraper plate and skid shoes on the bottom of the snow thrower are subject to wear. To prevent damage to the spiral auger housing, replace plate and shoes before wear is excessive.



# SERVICE AND ADJUSTMENTS



**CAUTION:** Before servicing or adjusting the snow thrower, shut off the engine, remove the spark plug wire(s), set the parking brake and remove the key from the tractor ignition.

## REPLACING AUGER BELT

- Disengage the tractor's attachment clutch.
- Lower the snow thrower to the ground.
- Remove the attachment pin.
- Lock the snow thrower's lift handle in the down position to decrease belt tension.
- Release the spring tension from the auger belt idler arm on the bottom of the clutch/idler assembly.
- Remove the auger drive belt from the clutch/idler assembly and from the spiral auger housing.
- Install new belt over top of large auger drive pulley and under the two side idler pulleys. Twist the belt 1/4 turn to seat the "V" of the belt in the groove of each idler pulley. Refer to figure 23 on page 14.
- Assemble the belt onto the clutch/idler assembly.

## SKID SHOE ADJUSTMENT

- The skid shoes are mounted on each side of the spiral auger housing. They regulate the distance the scraper plate is raised above the plowing surface. When removing snow from a gravel driveway or an uneven surface, it is advisable to keep the scraper plate as high above the surface as possible to prevent possible damage to the spiral auger. On blacktop or concrete surface, keep the scraper plate as close to the surface as possible.
- Raise the snow thrower off the ground and place a block under each end of the scraper plate. Loosen the six hex nuts securing the skid shoes to the housing. Adjust the skid shoes up or down and retighten the nuts securely. Adjust both skid shoes to the same height to keep the housing and the scraper plate level. See figure 27.

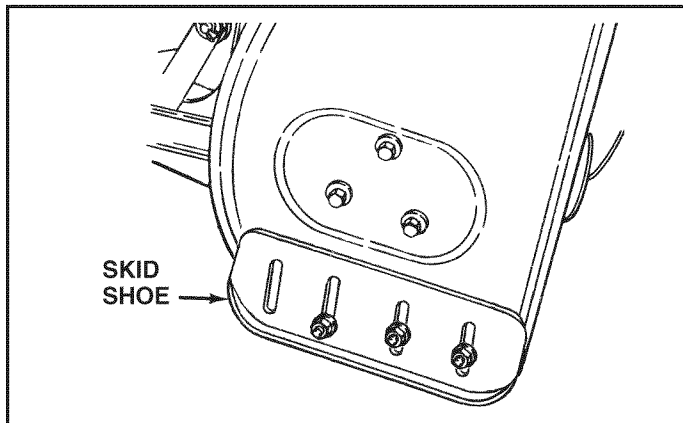

FIGURE 27

## LIFT RELEASE CABLE ADJUSTMENT

- If the lift rod does not lock the snow thrower securely in the transport position, loosen the upper hex nut on the lift bracket a few turns and tighten the lower hex nut. Refer to figure 16 on page 12.
- If the lift rod fails to unlock completely to lower the snow thrower, loosen the lower hex nut on the lift bracket a few turns and tighten the upper hex nut. Refer to figure 16 on page 12.

## SPIRAL AUGERS

- The spiral augers are secured to the auger shaft with two shear bolts and nylock nuts. If you hit a foreign object or if ice jams the augers, the snow thrower is designed so that the bolts will shear.
- If the augers will not turn, check to see if the shear bolts have sheared. See figure 28. Two replacement shear bolts and nylock nuts have been provided with the snow thrower. For future use order part number 710-0890A shear bolt and number 47810 nylock nut.

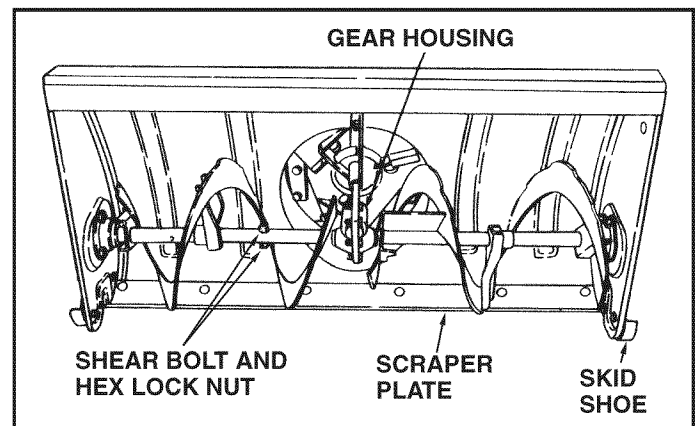

FIGURE 28

# STORAGE

## STORAGE RECOMMENDATIONS

- Lower the snow thrower to the ground.
- Remove the snow thrower from the tractor.
- Clean the snow thrower thoroughly. Wash off any salt deposit which may have dried on the thrower and housing.
- Any bare metal that has become exposed should be painted or coated with a light oil to prevent rust.
- Store in a dry place.

## REMOVING THE SPIRAL AUGER HOUSING

- Lower the snow thrower to the ground.
- Remove the attachment pin. See figure 22 on page 14.
- Lock the snow thrower's lift handle in the down position to decrease belt tension.
- Release the spring tension from the auger belt idler arm on the bottom of the clutch/idler assembly.
- Remove the auger drive belt from the clutch/idler assembly. See figure 24 on page 14.
- Pull the spiral auger housing assembly off of the tractor.

## SNOW THROWER PARTS TO REMOVE AT END OF SEASON

- Remove the belt guard from the tractor's PTO pulley by removing the two hex screws. (Refer to the Cutting Deck Removal instructions under SERVICE AND MAINTENANCE in your tractor operator's manual.)



**IMPORTANT:** Be sure to replace the belt guard before starting the engine to avoid damage to the electric clutch.

- Remove the belt from the PTO pulley.
- Reinstall the belt guard for the PTO pulley. Be sure the belt guard is installed in the notch on the side of the tractor's electric clutch.
- Loosen the two jam nuts on each support link.
- Loosen the 1/2" bolt and nut which fasten each support tube to the pulley frame.
- Remove the end of each support link from the front mounting plate and then slide the support links from the support tubes.
- Remove the hair cotter pins from the rear mounting brackets.
- Remove the hair cotter pins and pivot lock pins from the front mounting brackets and then remove the clutch/idler assembly from the tractor.
- If you are going to mount a bumper or other front end attachment to your tractor, remove the front mounting plates and frame brace by removing the quick release pins and pulling the mounting plates and frame brace off of the shoulder bolts.

## TROUBLESHOOTING

PROBLEM	CAUSE	CORRECTION
Spiral augers don't turn	<ol style="list-style-type: none"> <li>1. Upper or lower V belt too loose</li> <li>2. Upper or lower V belt broken</li> <li>3. Shear bolts are sheared.</li> </ol>	<ol style="list-style-type: none"> <li>1. Increase tension on V belt</li> <li>2. Replace V belt</li> <li>3. Replace shear bolts</li> </ol>
Clogged discharge chute	<ol style="list-style-type: none"> <li>1. Tractor ground speed too fast</li> <li>2. Tractor throttle set too low</li> <li>3. Snow too deep</li> <li>4. Snow melts during contact with the snow thrower</li> </ol>	<ol style="list-style-type: none"> <li>1. Use lower tractor gear</li> <li>2. Increase to full throttle</li> <li>3. Raise the snow thrower</li> <li>4. Allow snow thrower to cool to outdoor temperature before using</li> </ol>
Snow thrower stalls tractor engine	<ol style="list-style-type: none"> <li>1. Object jammed in spiral auger</li> <li>2. Hard or heavy snow</li> </ol>	<ol style="list-style-type: none"> <li>1. Stop engine, disengage the snow thrower clutch and clear the auger</li> <li>2. Increase to full throttle and decrease ground speed</li> </ol>
Front wheels slide instead of steering	Not enough traction at front wheels	<ol style="list-style-type: none"> <li>1. Increase scraper plate clearance by lowering skid shoes</li> <li>2. Pull down on lift handle to increase weight on front wheels</li> </ol>
Snow thrower rides up over snow	<ol style="list-style-type: none"> <li>1. Tractor ground speed too fast</li> <li>2. Bottom snow is icy or hard packed</li> </ol>	<ol style="list-style-type: none"> <li>1. Reduce ground speed</li> <li>2. Lower the skid shoes so that front of skid shoe is lower than the rear</li> </ol>

## NOTES

# PARTS

## REPAIR PARTS FOR MODEL 486.248371 42" SNOW THROWER (For Tractors With Model Numbers Beginning With 247)

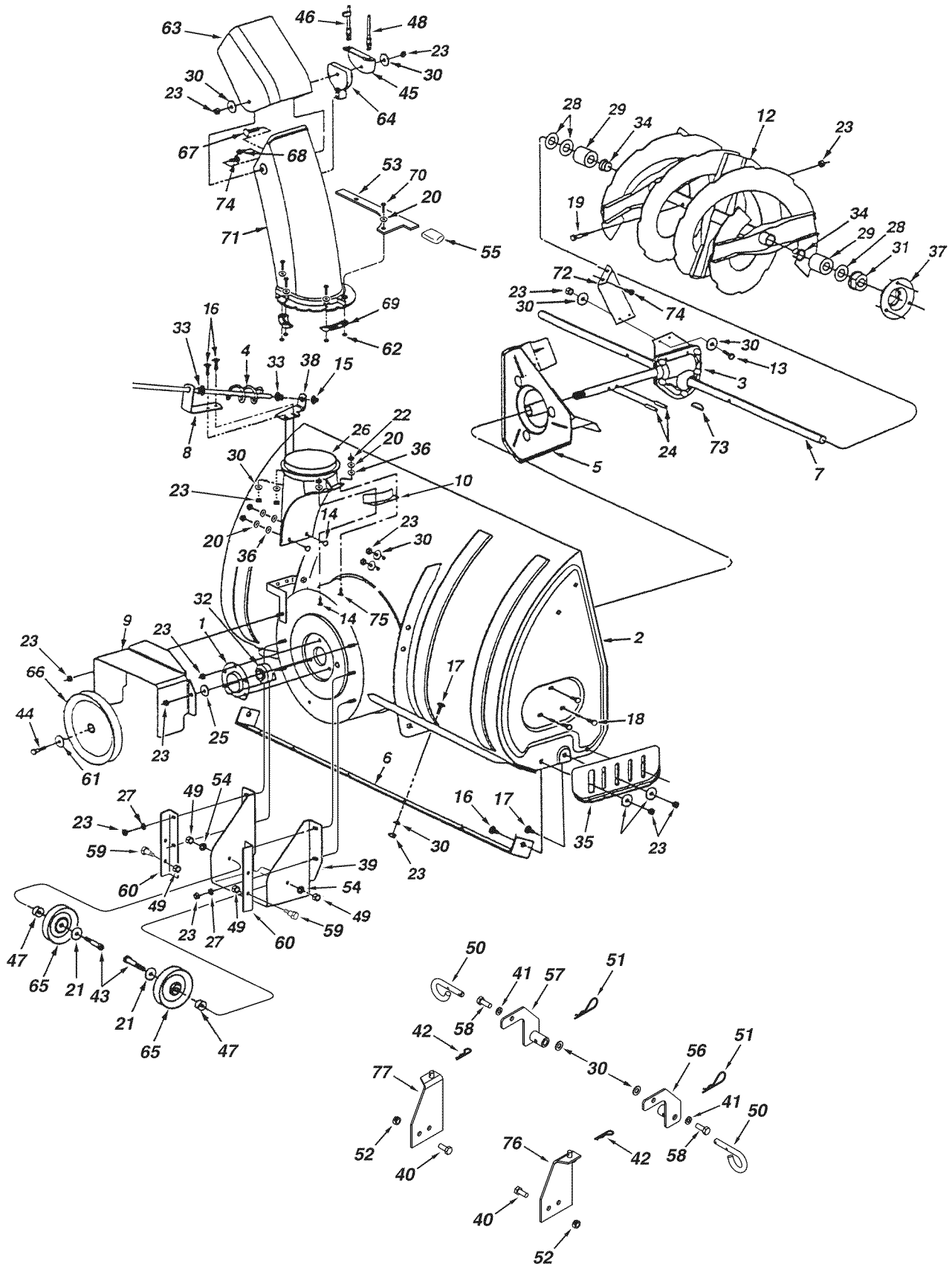

**REPAIR PARTS FOR MODEL 486.248371 42" SNOW THROWER  
(For Tractors With Model Numbers Beginning With 247)**

REF	PART NO	QTY	DESCRIPTION	REF	PART NO	QTY	DESCRIPTION
1	05931	1	Housing, Bearing	40	43182	2	Hex Bolt, 5/16 x 3/4"
2	65701	1	Housing Assembly	41	43086	2	Lock Washer, 5/16"
3	71464	1	Gear Assembly	42	47134	2	Hairpin Cotter, .08 x 1.58"
4	63579	1	Chute Crank Rod Assembly	43	41576	2	Hex Bolt, 3/8-16 x 1-3/4"
5	63768	1	Impeller Assembly	44	44377	1	Hex Bolt, 3/8-24 x 1"
6	24773	1	Scraper Plate	45	784-5594	1	Bracket, Cable
7	25982	1	Shaft, Auger Gearbox	46	746-0929	1	Cable, Chute Control With Clip
8	703-2735A	1	Bracket, Chute Crank	47	711-0242	2	Spacer
9	24816	1	Cover, Belt	48	746-0928	1	Cable, Chute Control
10	705-5226	1	Chute Reinforcement	49	HA21362	4	Hex Nut, 3/8-16 Nylock
11	705-5269	1	Spiral Assembly, L.H. (not shown)	50	43038	2	Pin, Pivot Lock
12	705-5270	1	Spiral Assembly, R.H.	51	43343	2	Pin, Hair Cotter #4 (1/8")
13	43840	2	Hex Bolt, 5/16-18 x 1-1/4" Lg.	52	43064	2	Lock Nut, 5/16"
14	44950	4	Carriage Bolt, 1/4-20 x 3/4"	53	24394	1	Bracket, Chute Anti-rotation
15	44917	1	Palnut, 3/8"	54	47572	2	Hex Lock Nut, 3/8-16 Flanged
16	44326	4	Carriage Bolt, 5/16-18 x 1" Lg.	55	1643-60	1	Plastic Cap
17	43080	10	Carriage Bolt, 5/16-18 x 3/4" Lg.	56	67052	1	Hanger Bracket Assembly, R.H.
18	46703	6	Bolt, Self-Tap 5/16" x 3/4"	57	67053	1	Hanger Bracket Assembly, L.H.
19	710-0890A	2	Bolt, Shear 5/16-18 x 1-1/2"	58	43063	2	Hex Bolt, 5/16 x 1"
20	43088	11	Washer, 1/4"	59	48106	2	Bolt, Shoulder
21	43070	2	Washer, 3/8"	60	24466	2	Bracket, Down Stop
22	47189	4	Hex Nut, 1/4-20 Nylock	61	736-0247	1	Washer,
23	47810	29	Hex Nut, 5/16-18 Nylock	62	47598	6	Hex Lock Nut, 1/4" Flanged
24	715-0114	2	Spiral Pin, 1/4" x 1-1/2" Lg.	63	731-0921	1	Chute, Upper
25	750-0437	1	Bushing	64	731-1313C	1	Guide, Cable
26	731-1379A	1	Chute Adapter	65	47044	2	Pulley, V Type 4"
27	43086	4	Lock Washer, 5/16"	66	47026	1	Pulley, V Type
28	43009	6	Washer, .785" x 1.57" x .057"	67	43085	1	Hex Bolt, 5/16-18 x 1-1/2"
29	711-0469	4	Spacer, .75 ID x 1.25 OD x .5 L	68	710-0896	1	Screw, 1/4-14 x 5/8"
30	43081	26	Washer, 5/16" Std. Wrt.	69	731-0851A	3	Chute Keeper
31	47615	2	Bearing, Flange	70	43661	6	Hex Bolt, 1/4-20 x 1"
32	741-0309	1	Bearing, Ball	71	731-1300C	1	Chute, Lower
33	741-0475	2	Bushing, Plastic 3/8"	72	25937	1	Center Brace, Gearbox
34	741-0493A	4	Bearing, Split, 3/4"	73	HA20185	1	#61 Woodruff Key
35	24279	2	Skid Shoe	74	43182	3	Hex Bolt, 5/16-18 x 3/4"
36	48015	4	Washer, Nylon	75	44940	1	Carriage Bolt, 1/4-20 x 3/4"
37	784-5618	2	Housing, Bearing	76	67266	1	Rear Frame Bracket, R.H.
38	24393	1	Bracket, Chute Crank	77	67267	1	Rear Frame Bracket, L.H.
39	27280	1	Bracket, Idler		42317	1	Owner's Manual



**REPAIR PARTS FOR MODEL 486.248371 42" SNOW THROWER  
(For Tractors With Model Numbers Beginning With 247)**

REF	PART NO	QTY	DESCRIPTION	REF	PART NO	QTY	DESCRIPTION
1	64637	1	Lift Shaft Assembly	38	46446	1	Grip, Handle
2	710-0865	2	Hex Bolt, 1/2-13 x 1"	39	47027	1	Tube, Crank Rod Support
3	710-0367	2	Hex Bolt, 5/8-11 x 1-1/2"	40	741-0475	2	Bushing, 3/8" Plastic
4	711-0332	2	Pin, Bracket Lift	41	703-2735A	1	Bracket, Chute Crank
5	712-0261	2	Nut, Hex Lock 5/8-11 Thread	42	720-0201A	1	Knob, Crank
6	43262	6	Nut, Hex Lock 1/2-13	43	44917	1	Palnut, 3/8"
8	142	5	Pin, Cotter 1/8" x 3/4"	45	63579	1	Assembly, Chute Crank Rod
9	43093	1	Pin, Cotter 1/8" x 1-1/2"	46	784-5604A	1	Handle, Chute Tilt
10	R19171616	4	Washer, 17/32" x 1"	47	720-04039	1	Knob
11	41346	2	Support Link	48	603-0302	1	Assembly, Chute Tilt Bracket
12	741-0192	2	Bearing, Flange With Flats	49	731-1313C	1	Guide, Cable
13	783-0380	2	Link, 15.80" Long	50	746-0928	1	Cable, Chute Control
14	783-0381	2	Link, 11.75" Long	51	746-0929	1	Cable, Chute Control with Clip
15	24476	2	Link, 4.88" Long	52	43064	5	Nut, Hex Lock 5/16-18
16	24311	1	Rod, Spacer	53	43081	2	Washer, 5/16"
17	47599	2	Hex Bolt, 5/16-18 x 1" (Locking)	54	24285	1	Plate, Mounting (L.H.)
18	43086	4	Lock Washer, 5/16"	55	24284	1	Plate, Mounting (R.H.)
19	24820	1	Bracket, Lift	56	43601	1	Washer, 1.59" x 1.032" x .060"
20	63773	1	Assembly, Handle Lift Bracket	57	712-3083	4	Nut, Nylock Hex 1/2-13
21	48049	1	Rod, Index Lift	58	R19172410	8	Washer, 1/2"
22	47369	1	Pin, Spring 3/16" x 1-3/4"	59	726-0178	3	Tie, Nylon
23	732-0306	1	Spring, Compression	60	43020	2	Hex Bolt, 1/2" x 1-1/2"
24	R19131316	2	Washer, 13/32" x 13/16"	61	27231	2	Spacer, 1/2"
25	47788	2	Reflector, Rear	62	47572	6	Nut, Flanged Lock 3/8-16
26	43080	1	Carriage Bolt, 5/16-18 x 3/4"	63	47810	8	Nut, Nylock Hex 5/16-18
27	43182	2	Hex Bolt, 5/16-18 x 3/4"	64	43084	2	Hex Bolt, 5/16-18 x 1-3/4"
29	47368	1	Pin, Spring 5/16" x 1-3/4"	65	25722	1	Frame Brace
30	46954	1	Pin, Attachment	66	48106	2	Bolt, Shoulder
31	43343	1	Pin, Haircotter #4 (1/8")	67	44695	2	Washer, Bowed
32	67268	1	Plate, Side (R.H.)	68	43682	2	Carriage Bolt, 5/16-18 x 1-1/4"
33	67269	1	Plate, Side (L.H.)	69	44215	2	Carriage Bolt, 5/16-18 x 1-3/4"
34	49916	1	Tube, Lift Handle	70	41352	2	Support Tube
35	49912	1	Trigger and Lift Cable Assembly	71	43351	2	Hex Bolt, 1/2" x 1-1/4"
36	43019	4	Nut, Hex Jam 1/2-13	72	47134	2	Small Hairpin Cotter
37	710-1233	1	Screw, Oval #10-24 x 1"	73	714-04061	2	Quick Release Pin

# REPAIR PARTS FOR MODEL 486.248371 42" SNOW THROWER

(For Tractors With Model Numbers Beginning With 247)

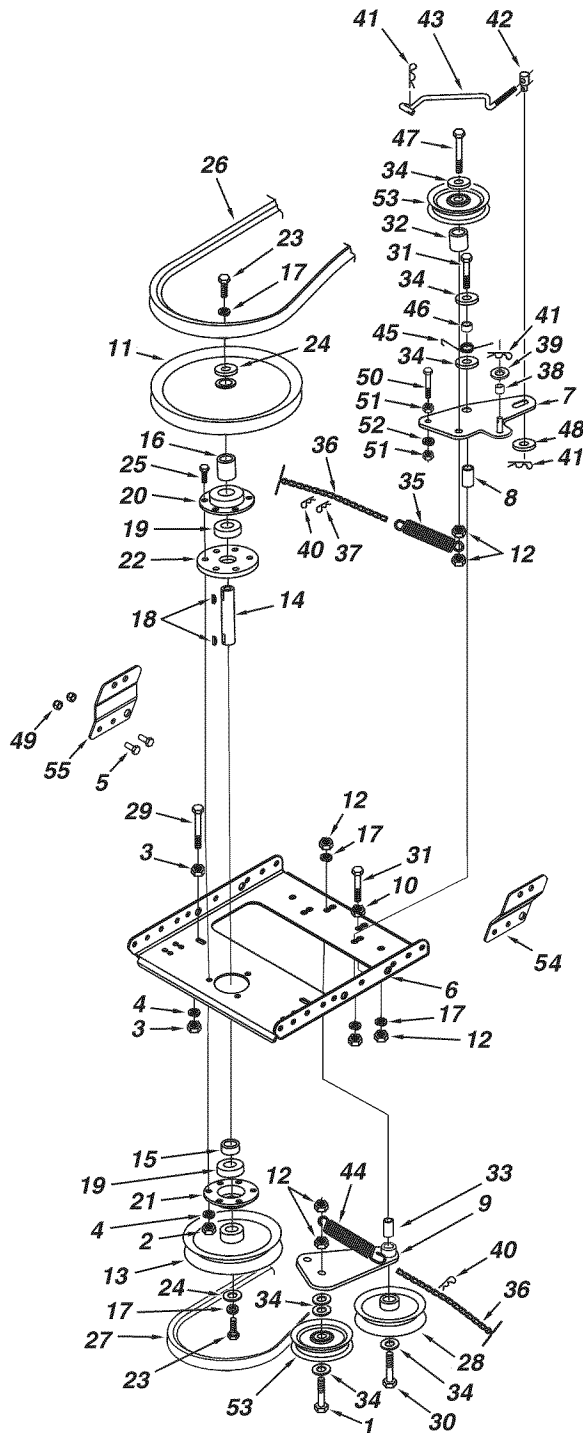

REF	PART NO	QTY	DESCRIPTION
8	24286	1	Spacer, Pivot
9	63762	1	Idler Bracket Assembly
10	43015	1	Hex Nut, 3/8-16
11	46981	1	Pulley, V Type 9"
12	43082	7	Nut, Hex Lock, 3/8-16
13	46982	1	Pulley, V Type 5-1/2"
14	738-0680	1	Shaft
15	750-0456	1	Spacer
16	750-0660	1	Spacer
17	43003	5	Lock Washer, 3/8"
18	714-0161	2	Key
19	741-0919	2	Bearing, Ball
20	08253B	1	Housing, Bearing
21	15296A	1	Housing, Open Bearing
22	14088B	1	Spacer, Spindle
23	44377	2	Hex Bolt, 3/8-24 x 1"
24	736-0247	2	Washer
25	43063	3	Hex Bolt, 5/16-18 x 1"
26	41353	1	Belt, V Type Drive (52")
	48138	1	Belt, V Type Drive (56")
27	47846	1	Belt, V Type Auger
28	47044	1	Pulley, V Type 4"
29	47025	1	Hex Bolt, 5/16-18 x 3-1/2"
30	43432	1	Hex Bolt, 3/8-16 x 2-1/2"
31	43054	3	Hex Bolt, 3/8-16 x 2"
32	24571	1	Spacer
33	24472	1	Spacer, Pivot
34	43070	7	Washer, 3/8"
35	46959	1	Spring
36	46963	2	Chain
37	43055	1	Pin, Hair Cotter, 3/32"
38	23727	1	Spacer
39	43088	1	Washer, 1/4"
40	43343	2	Pin, Hair Cotter #4 (1/8")
41	47134	2	Pin, Hair Cotter 5/64"
42	711-0198	1	Trunnion
43	46948	1	Rod, Engagement
44	47620	1	Spring
45	47607	1	Spring, Torsion
46	23625	1	Spacer
47	43509	1	Hex Bolt, 3/8-16 x 2-3/4" Lg.
48	47605	1	Washer, Flat 3/8"
49	47810	4	Hex Nut, 5/16-18 Nylock
50	49870	1	Hex Bolt, 1/4-20 x 2-1/2"
51	43178	2	Hex Nut, 1/4-20
52	43177	1	Lock Washer, 1/4"
53	48883	2	Pulley, Flat 3-5/8"
54	27010	1	Front Bracket, R.H.
55	27011	1	Front Bracket, L.H.

REF	PART NO	QTY	DESCRIPTION
1	HA180132	1	Hex Bolt, 3/8-16 x 2-1/4"
2	43064	3	Hex Lock Nut, 5/16-18
3	43083	2	Hex Nut, 5/16-18
4	43086	4	Lock Washer, 5/16"
5	43182	4	Hex Bolt, 5/16-18 x 3/4"
6	26943	1	Frame, Clutch and Pulley
7	63904	1	Idler Arm Assembly



# SUGGESTED GUIDE FOR SIGHTING SLOPES FOR SAFE OPERATION OF TRACTOR WITH ATTACHMENT

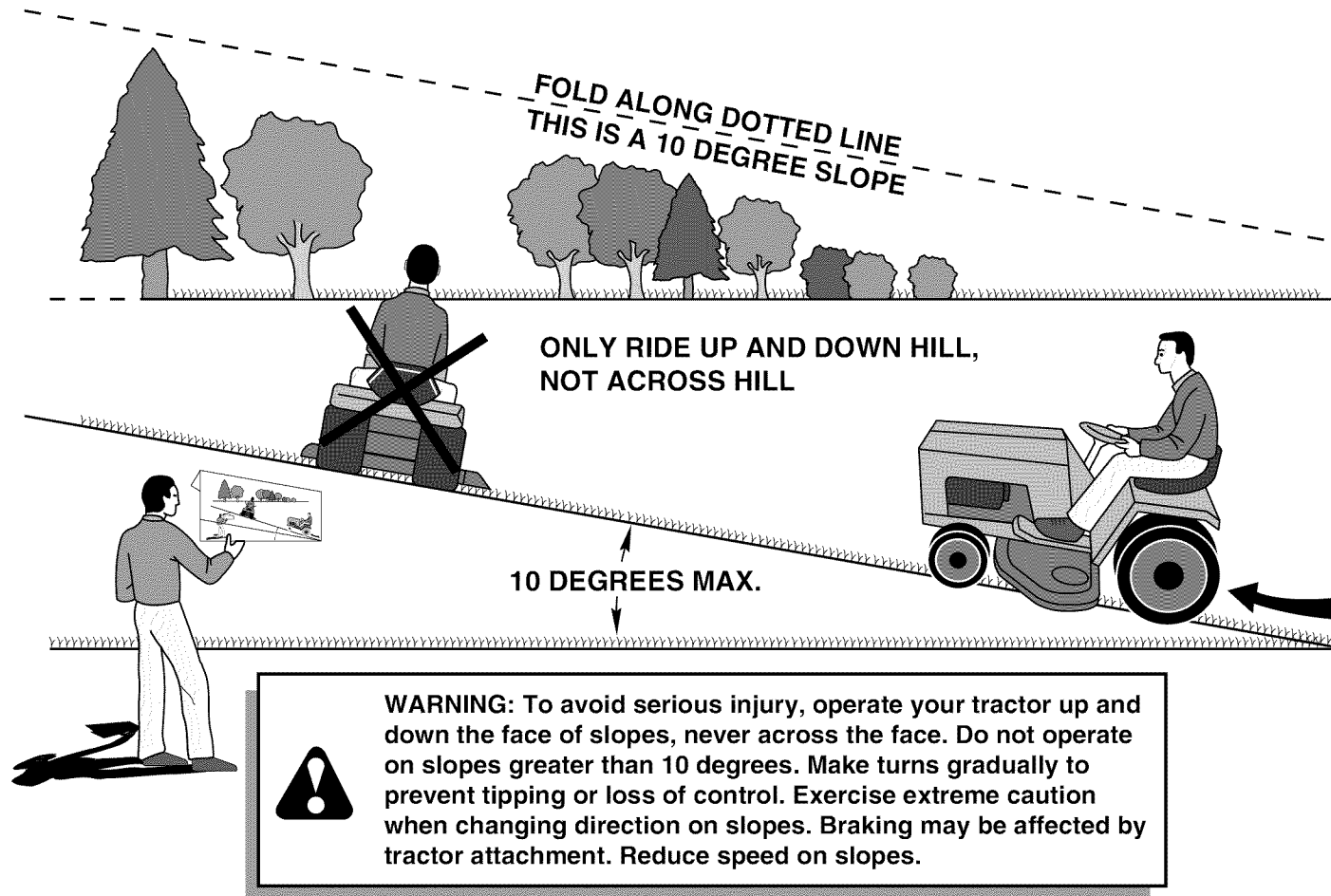

1. Fold this page along dotted line indicated above.
2. Hold page before you so that its left edge is vertically parallel to a tree trunk or other upright structure.
3. Sight across the fold in the direction of hill slope you want to measure.
4. Compare the angle of the fold with the slope of the hill.

# Get it fixed, at your home or ours!

## Your Home

For expert troubleshooting and home solutions advice:

**manage my home**

[www.managemyhome.com](http://www.managemyhome.com)

For repair – **in your home** – of **all** major brand appliances, lawn and garden equipment, or heating and cooling systems, **no matter who made it, no matter who sold it!**

For the replacement parts, accessories and owner's manuals that you need to do-it-yourself.

For Sears professional installation of home appliances and items like garage door openers and water heaters.

**1-800-4-MY-HOME<sup>®</sup>** (1-800-469-4663)

Call anytime, day or night (U.S.A. and Canada)

[www.sears.com](http://www.sears.com)    [www.sears.ca](http://www.sears.ca)

## Our Home

For repair of carry-in items like vacuums, lawn equipment, and electronics, call anytime for the location of your nearest

**Sears Parts & Repair Service Center**

**1-800-488-1222** (U.S.A.)

[www.sears.com](http://www.sears.com)

**1-800-469-4663** (Canada)

[www.sears.ca](http://www.sears.ca)

To purchase a protection agreement on a product serviced by Sears:

**1-800-827-6655** (U.S.A.)

**1-800-361-6665** (Canada)

Para pedir servicio de reparación a domicilio, y para ordenar piezas:

**1-888-SU-HOGAR<sup>®</sup>**

(1-888-784-6427)

Au Canada pour service en français:

**1-800-LE-FOYER<sup>MC</sup>**

(1-800-533-6937)

[www.sears.ca](http://www.sears.ca)

**Sears**

© Registered Trademark / <sup>TM</sup> Trademark / <sup>SM</sup> Service Mark of Sears Brands, LLC

© Marca Registrada / <sup>TM</sup> Marca de Fábrica / <sup>SM</sup> Marca de Servicio de Sears Brands, LLC

<sup>MC</sup> Marque de commerce / <sup>MD</sup> Marque déposée de Sears Brands, LLC

© Sears Brands, LLC