



INSTALLATION and SERVICE INSTRUCTIONS
USE and CARE INSTRUCTIONS

DOUBLE OVEN



distributed by
DèLonghi
Pty Ltd

Dear Customer,

Thank you for having purchased and given your preference to our product.

The safety precautions and recommendations reported below are for your own safety and that of others. They will also provide a means by which to make full use of the features offered by your appliance.

Please keep this booklet in a safe place. It may be useful in future, either to yourself or to others in the event that doubts should arise relating to its operation.

This appliance must be used only for the task it has explicitly been designed for, that is for cooking foodstuffs. Any other form of usage is to be considered as inappropriate and therefore dangerous.

The manufacturer declines all responsibility in the event of damage caused by improper, incorrect or illogical use of the appliance or by faulty installation.

PRODUCT LABEL



IMPORTANT PRECAUTIONS AND RECOMMENDATIONS FOR USE OF ELECTRICAL APPLIANCES

Use of any electrical appliance implies the necessity to follow a series of fundamental rules. In particular:

- Never touch the appliance with wet hands or feet;
- Do not operate the appliance barefooted;
- The appliance is not intended for use by young children or infirm persons without supervision;
- Young children should be supervised to ensure they do not play with the appliance.

The manufacturer cannot be held responsible for any damages caused by improper, incorrect or illogical use of the appliance.

USING THE OVENS FOR THE FIRST TIME

You are advised to carry out the following operations:

- Furnish the interior of the ovens.
- Switch the empty oven ON at maximum temperature for about two hours to eliminate traces of grease and smell from the components.
- Disconnect the appliance from the electric power supply and clean the interior of the oven with a cloth soaked in water and neutral detergent and dry thoroughly.

This oven has been designed and constructed in accordance with the following codes and specifications:

AS/NZS 60335-1 General Requirements for Domestic electrical appliances

AS/NZS 60335-2-6 Particular Requirements for Domestic electrical cooking appliances

AS/NSZ 1044 Electromagnetic Compatibility Requirements.

IMPORTANT PRECAUTIONS AND RECOMMENDATIONS

After having unpacked the appliance, check to ensure that it is not damaged.

In case of doubt, do not use it and consult your supplier or a professionally qualified technician. Packing elements (i.e. plastic bags, polystyrene foam, nails, packing straps, etc.) should not be left around within easy reach of children, as these may cause serious injuries.

- Do not attempt to modify the technical characteristics of the appliance as this may become dangerous to use.
- Do not carry out cleaning or maintenance operations on the appliance without having previously disconnected it from the electric power supply.
- After use, ensure that the knobs are in the off position.
- The appliance is not intended for use by young children or infirm persons unless they have been adequately supervised by a responsible person to ensure that they can use the appliance safely.
- During and after use of the appliance, certain parts will become very hot. Do not touch hot parts. Care should be taken to avoid touching heating elements inside the ovens.
- Keep children away from the appliance when it is in use.
- Young children should be supervised to ensure that they do not play with the appliance.
- Some appliances are supplied with a protective film on steel and aluminium parts. This film must be removed before using the appliance.
- Make sure that electrical cables connecting other appliances in the proximity of the oven do not become entrapped in the oven doors.
- Do not line the oven walls with aluminium foil. Do not place baking trays or the drip tray on the base of the oven chamber.
- **WARNING** When correctly installed, your product meets all safety requirements laid down for this type of product category. However special care should be taken around the rear or the underneath of the appliance as these areas are not designed or intended to be touched and may contain sharp or rough edges, that may cause injury.
- **Fire risk!** Do not store flammable material in the ovens.
- Always use oven gloves when removing the shelves and food trays from the oven whilst hot.
- Do not hang towels, dishcloths or other items on the appliance or its handle – as this could be a fire hazard.
- Clean the oven regularly and do not allow fat or oils to build up in the oven base or tray. Remove spillages as soon as they occur.
- Do not stand on the open oven doors.
- Always stand back from the appliance when opening the oven door to allow steam and hot air to escape before removing the food.
- This appliance is for domestic use only.
- Safe food handling: leave food in the oven for as short a time as possible before and after cooking. This is to avoid contamination by organisms which may cause food poisoning. Take particular care during warmer weather.
- The manufacturer declines all liability for injury to persons or damage to property caused by incorrect or improper use of the appliance.
- **WARNING: Taking care NOT to lift the oven by the door handles.**
- **IMPORTANT NOTE: This appliance shall not be used as a space heater, especially if installed in marine craft or caravans.**

INSTALLATION

CAUTION:

- This appliance must be installed in accordance with these installation instructions.
- This appliance shall only be serviced by authorized personnel.
- This appliance is to be installed only by an authorised person and in compliance with local safety standards.
- Incorrect installation, for which the manufacturer accepts no responsibility, may cause personal injury or damage.
- Always disconnect the oven from mains power supply before carrying out any maintenance operations or repairs.

ELECTRICAL REQUIREMENTS

- Connection to the mains must be carried out by qualified personnel in accordance with current regulations.
- The appliance must be connected to the mains checking that the voltage corresponds to the value given in the rating plate and that the electrical cable sections can withstand the load specified on the plate.
- The appliance must be connected directly to the mains placing a two pole switch with minimum opening between the contacts of 3 mm between the appliance and the mains.
- The power supply cable must not touch the hot parts and must be positioned so that it does not exceed 75°C at any point.
- Once the appliance has been installed, the switch must always be accessible.
- **If the supply cord is damaged it must be replaced by the manufacturer or its Service Agent or a similarly qualified person in order to avoid a hazard.**

WARNING: This appliance must be earthed. This oven must be connected to supply using V105 insulated cable.

- N.B.**
- **The connection of the appliance to earth is mandatory.**
 - **For connection to the mains, do not use adapters, reducers or branching devices as they can cause overheating and burning.**

If the installation requires alterations to the domestic electrical system call a qualified electrician. He should also check that the electrical system is suitable for the power drawn by the appliance.

CONNECTING THE FEEDER CABLE

- Unscrew the screw A securing the cover plate B behind the oven (fig. 1).
- Remove the cover plate B.
- Remove the screws C from the cable clamp (fig. 2).
- Insert the mains cable (type V105 - 3x2,5 mm² section) into the cable protector P.
- Connect the phase and earth cables to the mains terminal connection block D.
- The wires of this appliance must be coloured in accordance with the following code:

GREEN AND YELLOW - EARTH \perp

BLUE - NEUTRAL "N"

BROWN - LIVE "L"

- The wire which is coloured GREEN AND YELLOW must be connected to terminal which is marked with the letter "E" or by the Earth \perp symbol or coloured GREEN or GREEN AND YELLOW.
- The wire which is coloured BLUE must be connected to the terminal which is marked with the letter "N" or coloured BLACK.
- The wire which is coloured BROWN must be connected to the terminal which is marked with the letter "L" or coloured RED.
- Refit the cable clamp so that it clamps the outer sleeving of the cable, and screw the screws C.
- Refit the cover plate B and fix it with the screw A.

REPLACING THE POWER SUPPLY CABLE

If the supply cable is damaged, it must be replaced by the manufacturer or its service agent or a similarly qualified person in order to avoid a hazard.

Figure 1

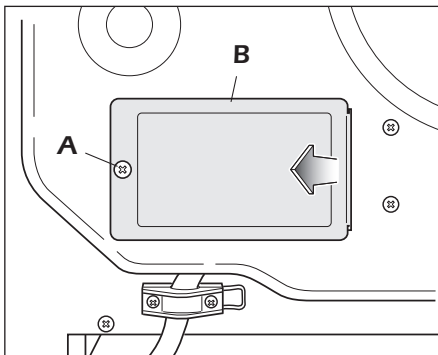
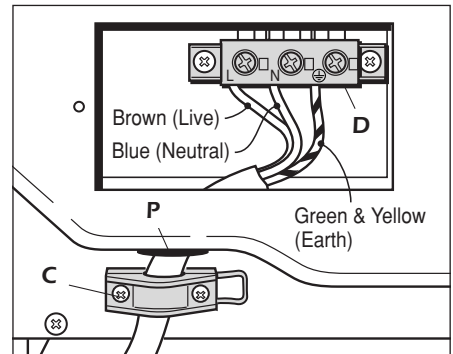
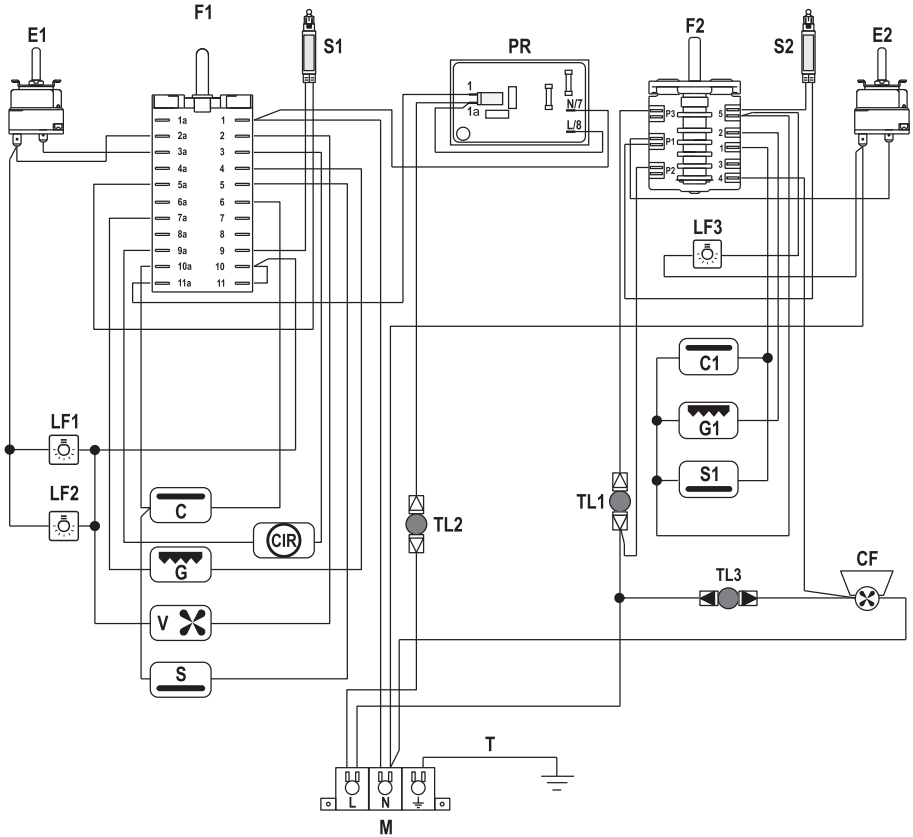

Figure 2



WARNING This appliance must be earthed

WIRING DIAGRAM



ELECTRIC DIAGRAM KEY

TOP OVEN

- F2 Oven switch
- E2 Oven thermostat
- S2 Thermostat pilot lamp
- LF3 Oven lamp
- C1 Top element
- G1 Grill element
- S1 Bottom element
- TL1 Thermal overload

BOTTOM OVEN

- F1 Oven switch
- E1 Oven thermostat
- S1 Thermostat pilot lamp
- LF1 Oven lamp
- LF2 Oven lamp
- PR Oven programmer
- LF Oven lamp
- C Top element
- G Grill element
- S Bottom element
- CIR Circular element
- V Fan
- TL2 Thermal overload
- CF Cooling fan
- TL3 Thermal overload
- M Terminal block
- T Earth connection

FITTING REQUIREMENTS

WARNING: Taking care NOT to lift the oven by the door handles.

IMPORTANT:

The appliance should be installed by a **QUALIFIED INSTALLATION TECHNICIAN**.

The appliance must be installed in compliance with regulations in force.

You need the following housing area to fit your oven correctly.

The double oven is designed to fit into a cabinet of 600 mm width.

The double oven can be built in the kitchen units, but you must ensure that it is properly ventilated.

In the diagram the appliance is ventilated by means of the space in the top of the kitchen cabinet.

Lift the appliance into position onto the shelf, taking care NOT to lift it by the door handles.

If you open the oven doors, you will see some screw holes.

The oven should then be secured to the housing by fitting screws into these holes. Remember the housing should not be free standing but be secured to the wall and/or adjacent fittings.

Dimensions (mm)	Oven	Housing
Height	888	877
Width	595	560
Depth	564	555 min.

- The appliance must be housed in heat resistant units.
- The walls of the units must be capable of resisting temperatures of 120 °C.

WARNING

When correctly installed, your product meets all safety requirements laid down for this type of product category.

However special care should be taken around the rear or the underneath of the appliance as these areas are not designed or intended to be touched and may contain sharp or rough edges, that may cause injury.

Figure 3

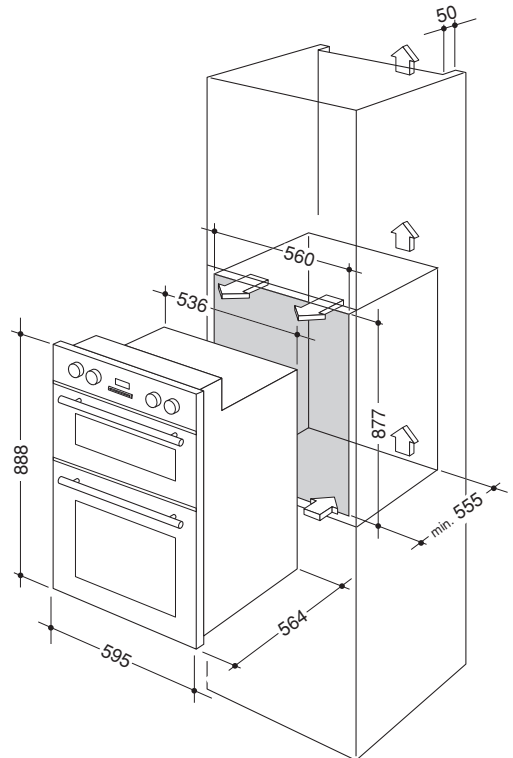
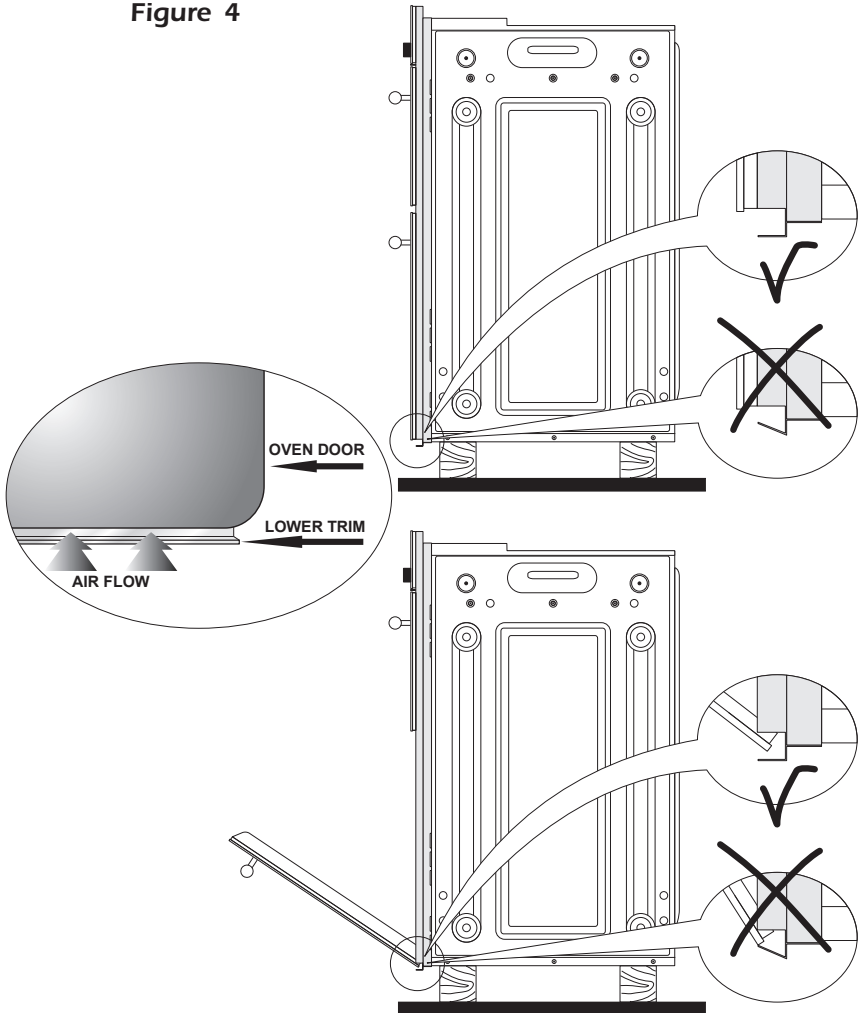

Figure 4



IMPORTANT:

To avoid damage to the lower trim please note the following instructions.

The lower trim is designed to allow for good air circulation and the correct opening of the oven door.

To ensure the trim is not damaged due to the appliance being placed on the floor, the appliance should be suitably supported as in above illustrations.

After installation the appliance door should be slowly opened to ensure no damage has occurred.

No responsibility for lower trim damage will be accepted if these instructions have not been followed.

USE and CARE

CAUTION:

- This appliance must be used only for the task it has explicitly been designed for, that is for domestic cooking of foodstuffs. Any other form of usage is to be considered as inappropriate and therefore dangerous.
- Do NOT place combustible materials or products on this appliance at any time.

USING THE BOTTOM MAIN OVEN FOR THE FIRST TIME

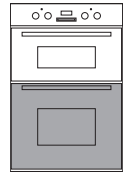



Operate as follows:

- Assemble the wire racks on the oven walls using the 2 screws interposing the catalytic panels **A** with the arrow up (fig. 5); the catalytic panel with the hole for the side oven lamp must be positioned on the left oven wall. DO NOT INTERPOSE THE CATALYTIC PANEL WITHOUT THE HOLE ON THE LEFT OVEN WALL.
- Slide in the grease filter on the back of the oven as in Fig. 8.
- Slide in, on the guides, the shelf and the tray (fig. 6). The rack must be fitted so that the safety catch, which stops it sliding out, faces the inside of the oven.

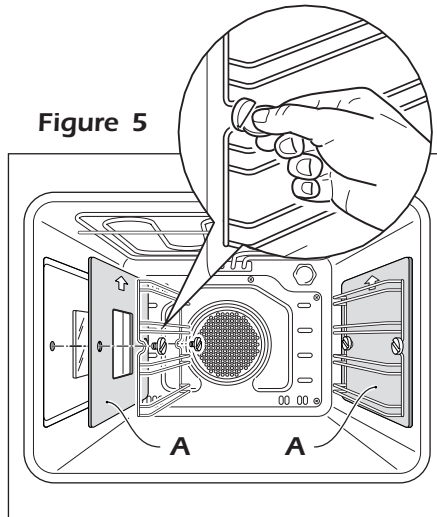
Figure 5



■ To eliminate traces of grease in manufacture it is necessary to pre-heat the oven at the maximum temperature:

- For 60 minutes in the  position, for 30 minutes in the  position and for another 15 minutes in the  position.

■ Unscrew the fixing screws and slide off the wire racks and the catalytic liners to the oven wall as in fig. 5.

The grill is secured to the rear wall of the oven on a hinge system that allows it to be lowered to allow proper access when cleaning the oven ceiling (see page 12).

■ Clean the inside of the oven with a cloth soaked in water and neutral detergent and dry thoroughly.

Figure 6

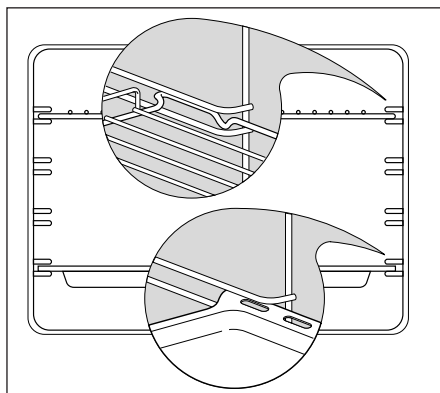

GREASE FILTER

(bottom main oven only)

- A special screen is provided at the back of the oven to catch grease particles, mainly when meat is being roasted (fig. 7).
- Clean the filter after any cooking! The grease filter can be removed for cleaning and should be washed regularly in hot soapy water (fig. 7).
- Always dry the filter properly before fitting it back into the oven.

CAUTION: When baking pastry etc. this filter should be removed.

Figure 7

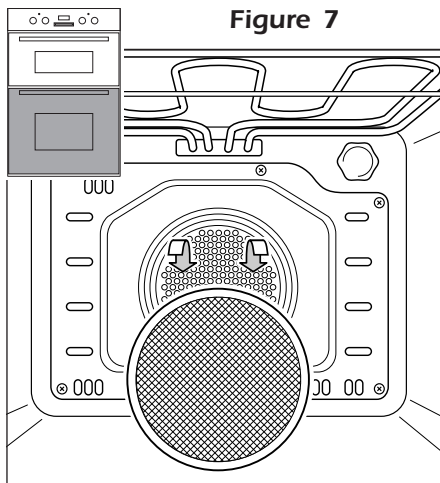

TILTING GRILL OF THE BOTTOM MAIN OVEN (fig. 8b)

- The grill is secured to the rear wall of the oven on a hinge system that allows it to be lowered to allow proper access when cleaning the oven ceiling (fig. 8b).
- To lower the grill element: use a flat-head screwdriver or a small coin to loosen the element fixing screw (fig. 8a).
- When you have finished cleaning the oven ceiling, raise the grill element and screw the element fixing screw back onto the stud.
- Make sure that the fixing screw is tightened and the element is held securely in place. The grill element itself is self-cleaning.

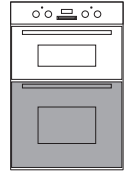

Figure 8a

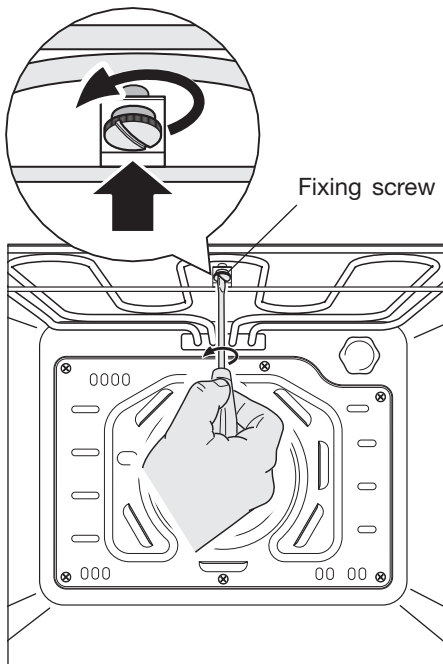
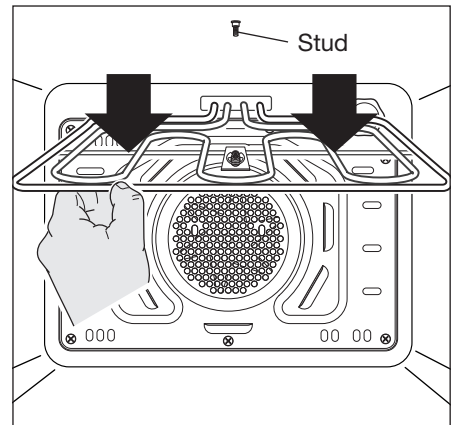
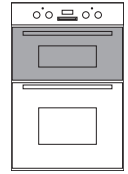



Figure 8b



USING THE TOP OVEN FOR THE FIRST TIME



You are advised to carry out the following operations:

- Assemble the wire racks to the oven walls using the 2 screws (Fig. 9).
- Slide into the guides, the shelf and the tray (fig. 10).
The shelf must be fitted so that the safety catch, which stops it sliding out, faces the inside of the oven.
- To eliminate traces of grease from the heating elements, switch on the oven on, to the maximum temperature in this ways:
For 60 minutes in the  position and for another 15 minutes in the  position.
- Unscrew the fixing screws and slide off the wire racks to the oven wall as in fig. 9. The grill is secured to the rear wall of the oven on a hinge system that allows it to be lowered to allow proper access when cleaning the oven ceiling (see page 14).
- Clean the inside of the oven with a cloth soaked in water and neutral detergent and dry thoroughly.

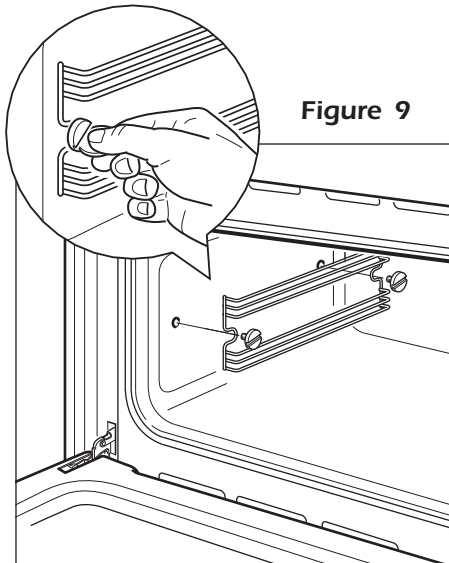

Figure 9

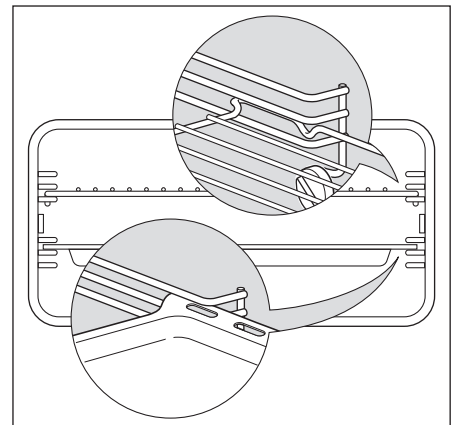
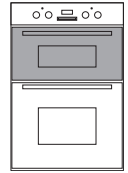

Figure 10

TILTING GRILL OF THE TOP OVEN (fig. 13)

- The grill is secured to the rear wall of the oven on a hinge system that allows it to be lowered to allow proper access when cleaning the oven ceiling (fig. 13).
- In the front the grill is secured to the ceiling by a hook **A**.



Unlocking the tilting grill (fig. 11)

1. Open the hook **A**.
2. Gently pull down the grill as shown in the figure 13.

Locking the tilting grill (fig. 12)

1. Gently lift up the grill.
2. Close the hook **A** on the grill bar.

Figure 11

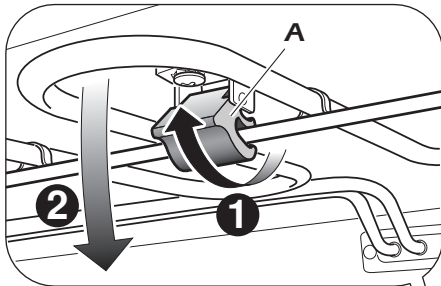

Figure 12

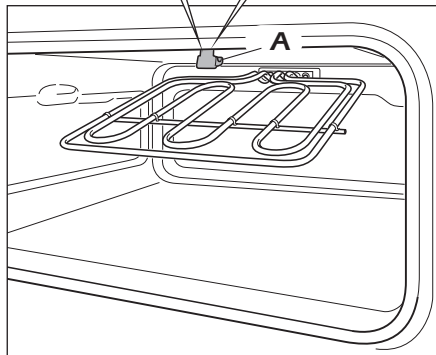
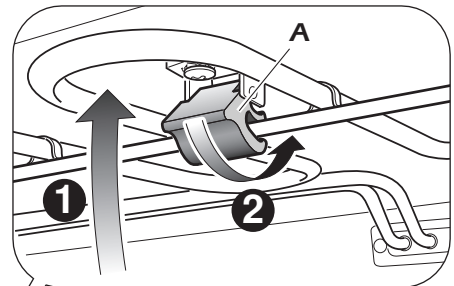

Figure 13

TELESCOPIC SLIDING SHELF SUPPORTS

The telescopic sliding shelf supports make it safer and easier to insert and remove the oven shelves and trays. They stop when they are pulled out to the maximum position.

Important! When fitting the sliding shelf supports, make sure that you fit:

- The slides to the top wire of a rack. They do not fit on the lower wire.
- The slides so that they run out towards the oven door.
- Both sides of each pair of shelf slides.
- Both sides on the same level.

To fix the sliding shelf support onto the side racks:

- Screw the side rack onto the oven wall (Figs. 5 - 9).
- Fit the sliding shelf support onto the top wire of a rack and press (Figs. 14 - 15). You will hear a click as the safety locks clip over the wire.

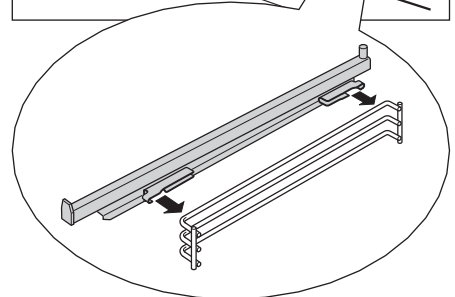
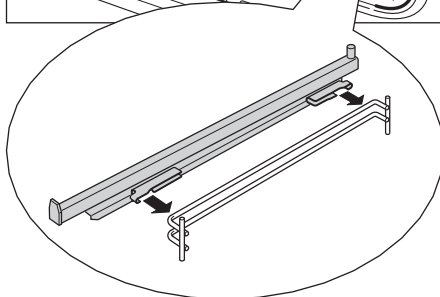
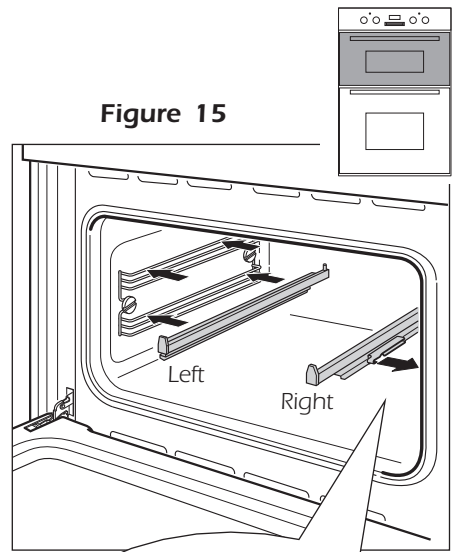
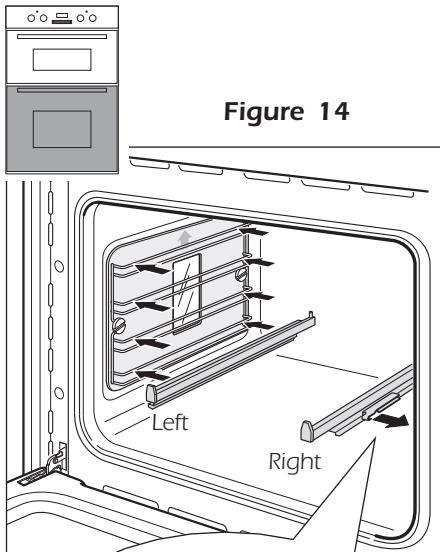

To remove the telescopic sliding shelf supports:

- Remove the side racks by unscrewing the fixing screws (Figs. 16 - 17).
- Lay down the telescopic sliding shelf support and side racks, with the telescopic sliding shelf support underneath.
- Find the safety locks. These are the tabs that clip over the wire of the side rack (arrow 1 in Fig. 18).
- Pull the safety locks away from the wire to release the wire (arrow 2 in Fig. 18).

Cleaning the sliding shelf supports

- Wipe the supports with a damp cloth and a mild detergent only.
- Do not wash them in the dishwasher, immerse them in soapy water, or use oven cleaner on them.

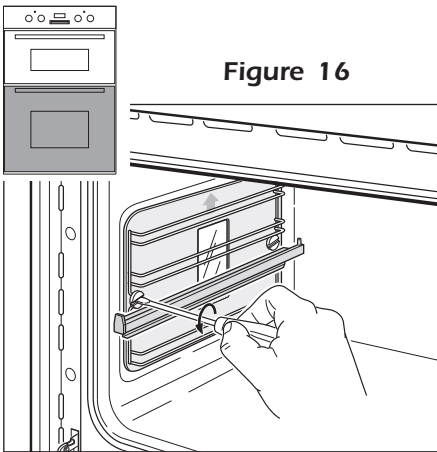

Figure 16

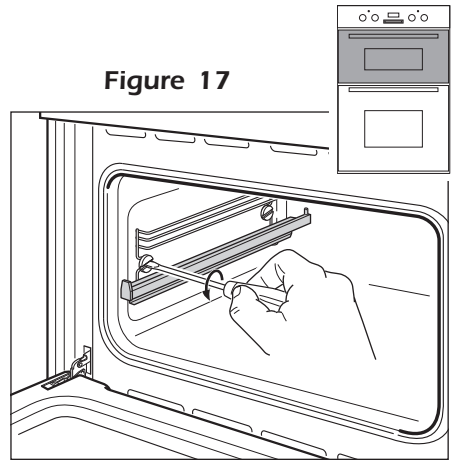

Figure 17

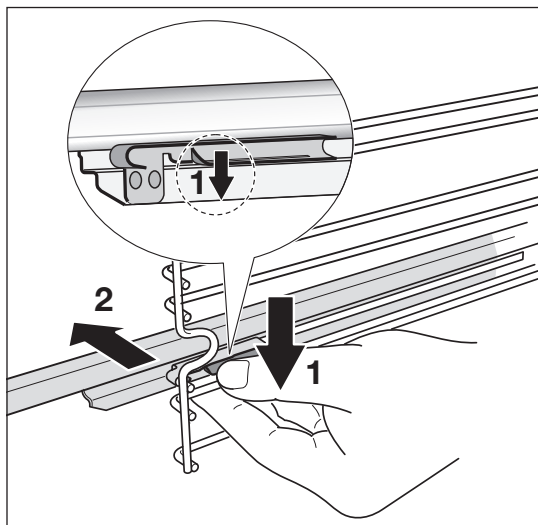

Figure 18

Control panel

Figure 19



CONTROL PANEL

1. Oven temperature knob (Top oven)
2. Function selector knob (Top oven)
3. Digital electronic programmer (Bottom main oven only)
4. Function selector knob (Bottom main oven)
5. Oven temperature knob (Bottom main oven)
6. Bottom main oven temperature indicator light
7. Top oven temperature indicator light

NB: Your appliance has been fitted with a cooling fan to achieve optimum efficiency of the controls and to ensure lower surface temperatures are maintained.

TOP OVEN

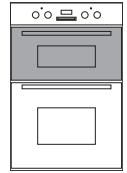

TOP OVEN GENERAL FEATURES

This is a CONVENTIONAL oven with 2 cooking options, thermostatically controlled.

TOP OVEN OPERATING PRINCIPLES

Heating and cooking in the CONVENTIONAL oven are obtained in two following ways:

a. by normal convection

The heat is produced by the upper and lower heating elements.

b. by radiation

The heat is irradiated by the infra red grill element.

WARNING:

The door is hot, use the handle.

During use the appliance becomes hot. Care should be taken to avoid touching heating elements inside the oven.

Figure 20

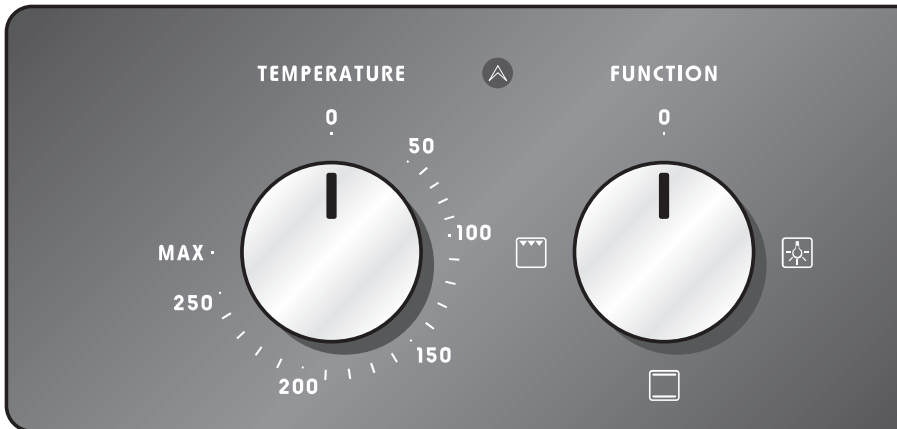

THERMOSTAT KNOB

This only sets the cooking temperature and does not switch the oven on. Rotate clockwise until the required temperature is reached (from 50 to MAX).

FUNCTION SELECTOR KNOB

Rotate the knob clockwise to set the oven for one of the following functions.



OVEN LIGHT

By setting the knob to this position, only the oven light comes on. It remains on in all the cooking modes.



TRADITIONAL CONVECTION COOKING

The upper and lower heating elements come on. The heat is dispersed by natural convection and the temperature must be set to between 50 °C and MAX via the thermostat knob.

The oven must be preheated before cooking.

Ideal for:

Food that requires the same degree of cooking both inside and out, for example roasts, spare pork ribs, meringues etc.



GRILLING

The infra-red heating element is switched on. The heat is diffused by radiation. Use with the oven door **closed** and the temperature knob set between 50 °C and 200 °C. For correct use see chapter "USE OF THE GRILL".

Ideal for:

Intense grilling, browning, cooking au gratin and toasting etc.

Always grill with the oven door closed.

It is recommended that you do not grill for longer than 30 minutes at any one time.

Caution: The oven door becomes very hot during operation. Keep children well out of reach.

COOKING ADVICE

Remember to keep children away from the appliance when you use the grill or oven, since these parts become very hot.

COOKING IN A CONVENTIONAL TOP OVEN

The oven has two heating elements, one on the base and one on the roof of the cooker. Hot air rises, so the top of the oven is always the hottest. The temperature in the middle of the oven is maintained at the temperature set by the control knob, and is slightly hotter above and cooler below.

In a conventional oven, dishes requiring different temperatures can be cooked in the oven at the same time - e.g. roast beef and Yorkshire pudding.

Always pre-heat a conventional oven before use. The oven indicator light will go out when the required temperature is reached. Do not open the oven door during cooking unless absolutely necessary.

IMPORTANT: Drip trays, baking trays etc. must not be left on the base of the oven as this could damage the appliance.

USE OF THE GRILL

Leave to warm up for approximately 5 minutes with the door **closed**. Place the food inside positioning the rack as near as possible to the grill. Insert the drip pan under the rack to collect the cooking juices.

Always grill with the oven door closed.

It is recommended that you do not grill for longer than 30 minutes at any one time.

Remember to keep children away from the appliance when you use the grill or oven, since these parts become very hot.

BOTTOM MAIN OVEN

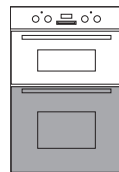

GENERAL FEATURES

This is a MULTI-FUNCTION oven. As its name indicates, this is an oven that presents particular features from an operational point of view. In fact, it is possible to insert 6 different programs to satisfy every cooking need. The 6 positions, thermostatically controlled, are obtained by 4 heating elements (top, bottom, grill and circular).

BOTTOM OVEN OPERATING PRINCIPLES

Heating and cooking in the **MULTI-FUNCTION** oven are obtained in the following ways:

a. by normal convection

The heat is produced by the upper and lower heating elements.

b. by forced convection

The fan draws in air contained within the oven housing at the rear of the oven and forces it over the circular heating element. The hot air envelops the food in the oven giving faster and more even cooking before it is drawn back into the housing to repeat the cycle. It is possible to cook several dishes simultaneously due to the even distribution of heat within the oven.

c. by forced semi-convection

The heat produced by the top and bottom heating elements is distributed throughout the oven by the fan.

d. by radiant heat

The food is grilled by the infra red grill element.

e. by radiant heat and ventilation

The food is grilled by the grill element is distributed throughout the oven

f. by ventilation

The food is defrosted by using the fan only function without heat.

WARNING:

The door is hot, use the handle.

During use the appliance becomes hot. Care should be taken to avoid touching heating elements inside the oven.

Figure 21

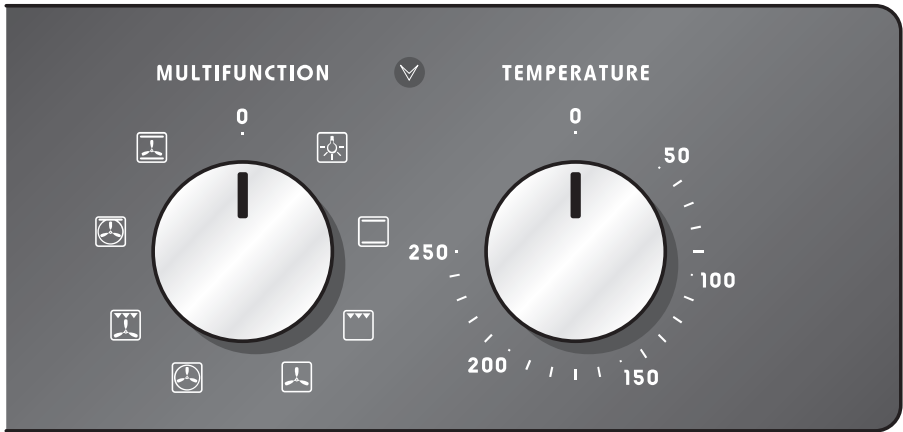

THERMOSTAT KNOB

This only sets the cooking temperature and does not switch the oven on. Rotate clockwise until the required temperature is reached (from 50 °C to 250 °C).

FUNCTION SELECTOR KNOB

Rotate the knob clockwise to set the oven for one of the following functions.



OVEN LIGHT

By setting the knob to this position, only the oven light comes on. It remains on in all the cooking modes.



TRADITIONAL CONVECTION COOKING

The upper and lower heating elements come on. The heat being dispersed by natural convection. The temperature range must be set between 50 °C and 250 °C using the thermostat.

The oven must be preheated before cooking.

Ideal for:

Food that requires the same degree of cooking both inside and out, for example roasts, spare pork ribs, meringues etc.



GRILLING

The infrared grill element at the top of the oven comes on. The heat is dispersed by radiation.

Use with the **oven door closed** and the temperature knob set between 50 °C and 200 °C max.

For cooking hints, see the chapter "USE OF THE GRILL".

Ideal for:

Intense grilling, browning, cooking au gratin and toasting etc.

Always grill with the oven door closed.

It is recommended that you do not grill for longer than 30 minutes at any one time.

Attention: The oven door becomes very hot during operation.

Keep children away.



DEFROST

Only the oven fan comes on. Use with the thermostat knob set to "0" - other temperature have no effect. The food is thawed by ventilation without heating.

Ideal for:

Quick thawing of frozen foods; one kg requires approximately 1 hour.

Thawing times vary according to the quantity and type of food to be thawed.



FAN FORCED

The circular element and fan come on. The heat is dispersed by forced convection and the temperature can be varied to between 50 °C and 250 °C via the thermostat knob. The oven does not require preheating.

Ideal for:

Food which has to be well-cooked outside and soft or rosy inside, for example lasagne, lamb, roast beef, whole fish etc.



FAN GRILL

Both the grill and the fan come on. Most of the cooking is done by grilling and then the hot air circulated around the oven. The oven door should be kept **closed**. The temperature can be set between 50 °C and 200 °C max. The oven should be preheated for 5 minutes before cooking. For further cooking hints see "GRILLING AND COOKING AU GRATIN".

Always grill with the oven door closed.

Ideal for:

Quick sealing in of food juices for example such as hamburger, chicken pieces, chops.

It is recommended that you do not grill for longer than 30 minutes at any one time.

Attention: The oven door becomes very hot during operation.

Keep children well out of reach.



MAINTAINING TEMPERATURE AFTER COOKING OR SLOWLY HEATING FOODS

The upper element, the circular element and the fan come on. The heat is circulated by forced convection with greater intensity in the upper part. The temperature can be set to between 50 °C and 140 °C via the thermostat knob.

Ideal for:

Keeping food warm after any type of cooking. Slow heating of cooked food.



CONVECTION COOKING WITH VENTILATION

The upper and lower heating elements and the fan turn on. The heat coming from the top and bottom is diffused by forced convection. The temperature must be set between 50 °C and 250 °C position with the temperature knob.

Ideal for:

Large bulky quantities of food that require even cooking throughout for example large roasts, turkey, roast turkey, cakes etc.

COOKING ADVICE

Remember to keep children away from the appliance when you use the grill or oven, since these parts become very hot.

STERILIZATION

Sterilization of foods to be preserved, in full and hermetically sealed jars, is done in the following way:

- a. Set the switch to position .
- b. Set the thermostat knob to position 185 °C and preheat the oven.
- c. Fill the dripping pan with hot water.
- d. Set the jars onto the dripping pan making sure they do not touch each other and the door and set the thermostat knob to position 135 °C.

When sterilization has begun, that is, when the contents of the jars start to bubble, turn off the oven and let cool.

Check your recipe book for full instructions.

WARMING BREAD

Set the switch to position  and the thermostat knob to position 150° C.

Bread becomes fragrant again if wet with a few drops of water and put into the oven for about 10 minutes at the highest temperature.

SIMULTANEOUS COOKING OF DIFFERENT FOODS

The oven set on position  can cook several different foods together. Foods as diverse as fish and cakes can be cooked together without the cross transference of flavours. This is because the fats and cooking smell that would normally be deposited on the different foods are oxidised and are not absorbed by the foods. The cooking temperature of the foods, however must be within 20°-25°C of each other. The food with the longest cooking time will be put into the oven first and the other foods are added as necessary according to their cooking times.

ROASTING

To obtain classical roasting, it is necessary to remember:

- that it is advisable to maintain a temperature between 180° and 200 °C.
- that the cooking time depends on the quantity and the type of foods.

GRILLING AND COOKING AU GRATIN

As the hot air completely covers the food to be cooked, grilling may be done with the food on the rack in the oven. The knob should be switched to position . The thermostat should be set to 50 °C and 200 °C max and the oven pre-heated. The food should be placed on a rack in the oven for the required cooking time. Adding a few dabs of butter before the end of the cooking time gives the golden “au gratin” effect.

Always grill with the oven door closed.

USE OF THE GRILL

Preheat the oven for about 5 minutes with the door closed.

Introduce the food to be cooked, positioning the rack as close to the grill as possible.

The dripping pan should be placed under the rack to catch the cooking juices and fats.

Always grill with the oven door closed.

WARNING: Accessible parts may become hot when the grill is used. Children should be kept away.



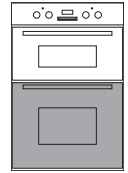



Electronic programmer (Bottom main oven only)



The electronic programmer is a device which groups together the following functions:

- 24 hours clock with illuminated display
- Timer (up to 23 hours and 59 minutes)
- Program for automatic oven cooking
- Program for semi-automatic oven cooking

Description of the buttons:

-  Timer
-  Cooking time
-  End of cooking time
-  Manual position and cancellation of the inserted cooking programme
-  Advancement of the numbers of all programs
-  Turning back of the numbers of all programs and changing the frequency of the audible signal.

Description of the illuminated symbols:

AUTO -flashing - Programmer in automatic position but not programmed

AUTO - always illuminated - Programmer in automatic position with program inserted.

 Automatic cooking taking place

 Timer in operation

 and **AUTO** - flashing - Program error.

(The time of day lies between the calculated cooking start and end time).



Note: Select a function by the respective button and, in 5 seconds, set the required time with the  /  buttons ("one-hand" operation). A power cut zeroes the clock and cancels the set programmes.

Figure 22



ELECTRONIC CLOCK (fig. 23)





The illuminated figures on the clock represent hours and minutes on 24 hour clock. When first connected, or after a power failure, three zeros will flash on the display. To set the time press the  button and then the  or . Please note that changing the hour button deletes any cooking program.

Figure 23



NORMAL COOKING WITHOUT THE USE OF THE PROGRAMMER

To manually use the oven without the aid of the programmer, it is necessary to cancel the flashing AUTO by pushing the button  (AUTO will be switched off and the symbol  will come on - Fig. 24).





Attention: If the **AUTO** symbol is on, a cooking program has already been programmed. By pressing the  you can cancel the set program & switch to manual mode. If the oven is switched on, you must manually switch it off.

Figure 24





ELECTRONIC TIMER

The timer program consists only of a buzzer which may be set for a maximum period of 23 hours and 59 minutes. If **AUTO** is flashing on the panel, push the  button.

To set the time, push the  button and the  or  until you obtain the desired time on the panel (fig. 25).

Having finished the setting, the clock hour will appear on the panel and the  will be illuminated.

The countdown will start immediately and the time remaining is shown by pressing the .

At the end of the elapsed time, the  will go out and an intermittent buzzer will go off; this can be stopped by pressing any of the buttons.

SETTING THE FREQUENCY OF THE AUDIBLE SIGNAL

The selection from 3 possibilities of sound can be made by pressing the  button.

Figure 25











AUTOMATIC OVEN COOKING



To cook food automatically in the oven, it is necessary to:

1. Set the length of the cooking time
2. Set the end of the cooking time
3. Set the temperature and the oven cooking program.

These operations are performed as follows:

1. Set the length of the cooking time by pushing the  button and the  button to advance, or  to go back if you have passed the desired time (fig. 26). The **AUTO** and the  symbol will be on.
2. Set the end of the cooking time by pressing the  button (the cooking time already added to the clock time will appear), and the  button (fig. 27); if you pass the desired time you may get back by pushing the  button. After this setting, the  symbol will go off. If after this setting, the **AUTO** flashes on the panel and a buzzer sounds, it means there was an error in the programming. If this is the case, modify the end of cooking time or the cooking time itself by repeating the procedure above.
3. Set the temperature and the cooking program by using the switch and thermostat knobs of the oven (see specific chapters).

The oven is now set to turn on and off at the programmed times.

During cooking, the  symbol remains on. By pushing the  button you can see the time that remains until the end of cooking.

The cooking program may be cancelled in any time by pushing .

At the end of the cooking time the oven will turn off automatically, the  symbol will turn off, **AUTO** will flash and a buzzer will sound, which can be turned off by pushing any of the buttons.

Turn the temperature and thermostat knobs to zero and set the programmer to “manual” by pressing the .



Attention: A power failure resets the clock back to zero and cancels the set programs. After a power failure, three zeros will flash on the panel.

Figure 26





SEMI - AUTOMATIC COOKING

This function is only used to set the END of the cooking time of the oven. There are two ways of setting this function.

1. Set the length of the cooking time by pushing the  button and the  button to advance, or  to go backwards (Fig. 26). This sets the desired "stop" time.



or

2. Set the end of the cooking time by pushing the  button and the  button to advance, or  to go backwards if you have passed the desired time (Fig. 27).

AUTO and the  symbol will be on.

Then set the temperature and the cooking program using the oven switch and thermostat knob (see relevant sections for details).

The oven is now set to turn on and off at the programmed times.

During cooking, the  symbol remains on and by pressing the button  you can see the time that remains till the end of the cooking.

The cooking time can be cancelled at any time by pushing the  button.

At the end of the cooking, the  symbol will turn off, the **AUTO** will flash and a buzzer will sound. The buzzer can be cancelled by pressing any of the buttons.

Turn the temperature and thermostat knobs to zero and set the programmer to "manual" by pressing the  button.

Figure 27



CLEANING and MAINTENANCE

GENERAL ADVICE

- **Before you begin cleaning, you must ensure that the appliance is switched off.**
- It is advisable to clean when the appliance is cold and especially when cleaning the enamelled parts.
- Avoid leaving alkaline or acidic substances (lemon juice, vinegar, etc.) on the surfaces.
- Avoid using cleaning products with a chlorine or acidic base.
- **Do not use a steam cleaner because the moisture can get into the appliance thus make it unsafe.**
- Stainless steel surfaces: clean with a suitable product. Always dry thoroughly.

Do not use harsh abrasive cleaners or sharp metal scrapers to clean the oven door glass since they can scratch the surface, which may result in shattering of the glass.

WARNING

When correctly installed, your product meets all safety requirements laid down for this type of product category. However special care should be taken around the rear or the underneath of the appliance as these areas are not designed or intended to be touched and may contain sharp or rough edges, that may cause injury.

ENAMELLED PARTS

- All of the enamelled parts must be washed only with a sponge and soapy water or with non-abrasive products.
- Dry preferably with a microfibre or soft cloth.

STAINLESS STEEL SURFACE

- The stainless steel front panels on this double oven (facia, oven doors) are protected by a finger-print proof lacquer. To avoid damaging this lacquer, do not clean the stainless steel with abrasive cleaners or abrasive cloths or scouring pads.

ONLY SOAP/WARM WATER MUST BE USED TO CLEAN THE STAINLESS STEEL SURFACES.

PAINTED PARTS AND SILKSCREEN PRINTED SURFACES

Clean using an appropriate product. Always dry thoroughly.

IMPORTANT: these parts must be cleaned very carefully to avoid scratching and abrasion. You are advised to use a soft cloth and neutral soap.

CAUTION: Do not use abrasive substances or non-neutral detergents as these will irreparably damage the surface.

GLASS CONTROL PANEL

Clean using an appropriate product.

Always dry thoroughly.

Do not use harsh abrasive cleaners or sharp metal scrapers to clean the control panel since they can scratch the surface, which may result in shattering of the glass.

INSIDE OF OVENS

- Every oven should always be cleaned after use when it has cooled down. The cavity should be cleaned using a mild detergent solution and warm water. Suitable proprietary chemical cleaners may be used after first consulting with the manufacturers recommendations and testing a small sample of the oven cavity. Abrasive cleaning agents or scouring pads/cloths should not be used on the cavity surface.
- **NOTE:** The manufacturers of this appliance will accept no responsibility for damage caused by chemical or abrasive cleaning.
- **Do not store flammable material in the ovens.**
- **Let the oven cool down and pay special attention no to touch the hot heating elements inside the oven cavity.**

TILTING GRILL (TOP OVEN AND BOTTOM MAIN OVEN)

- The grill heating element is self-cleaning and does not require maintenance. The grill is secured to the rear wall of the oven on a hinge system that allows it to be lowered to allow proper access when cleaning the oven ceiling (see pages 12, 14).

ADVICE FOR USE AND MAINTENANCE OF CATALYTIC PANELS (BOTTOM MAIN OVEN ONLY)

The catalytic panels are covered with special microporous enamel which absorbs and does away with oil and fat splashes during normal baking over 200°C.

If, after cooking very fatty foods, the panels remain dirty, operate the oven "idling" on max temperature for about 30 minutes.

These panels do not require to be cleaned, however it is advised to periodically remove them from the oven (at least the side panels) and to wash them with tepid soapy water and then wipe off with a soft cloth.

DO NOT CLEAN OR WASH THEM WITH ABRASIVE PRODUCTS OR WITH PRODUCTS CONTAINING ACIDS OR ALKALIS.

The side panels are reversible and when the catalytic microporous enamel degrades, they can be turned to the other side.

To remove and reassemble the catalytic panels see chapter USING THE BOTTOM MAIN OVEN FOR THE FIRST TIME at page 10).

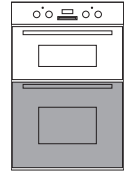

GREASE FILTER (BOTTOM MAIN OVEN ONLY)

- Clean the filter after any cooking! The grease filter can be removed for cleaning and should be washed regularly in hot soapy water (fig. 28).
- Always dry the filter properly before fitting it back into the oven.

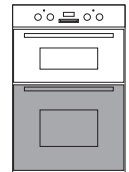
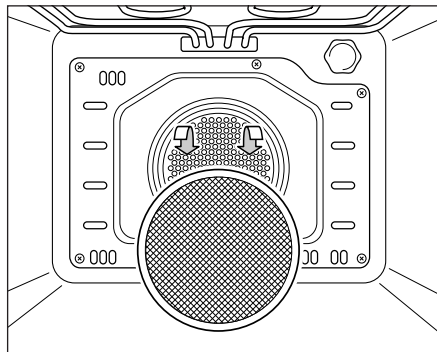

Figure 28



REPLACING THE OVEN LAMPS

WARNING: Ensure the appliance is switched off before replacing the lamp to avoid the possibility of electric shock.

- Let the oven cavities and the heating elements to cool down;
- Switch off the electrical supply;

TOP RIGHT LAMP (TOP AND BOTTOM MAIN OVEN):

- Remove the protective cover **C** (fig. 29);
- Unscrew and replace the bulb **B** with a new one suitable for high temperatures (300°C) having the following specifications: 230-240V 50 Hz, E14 and same power (check watt power as stamped in the bulb itself) of the replaced bulb.
- Refit the protective cover;

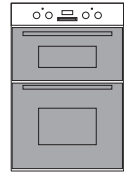

LEFT LAMP (BOTTOM MAIN OVEN ONLY):

- Remove the left wire rack and the side catalytic panel by unscrewing the fixing screws.
- Press down from the top the protective cover **A** (fig. 29) and remove it by rotating on the lower side. **IMPORTANT:** never use screwdrivers or other utensils to remove the cover **A**. This could damage the enamel of the oven or the lampholder. Operate only by hands.
- Unscrew and replace the bulb **B** with a new one suitable for high temperatures (300°C) having the following specifications: 230-240V 50 Hz, E14 and same power (check watt power as stamped in the bulb itself) of the replaced bulb.
- Refit the protective cover **A** operating in reverse order. **ATTENTION:** the notch in the inner edge of the cover must be oriented toward the lamp.
- Assemble the left wire rack and the side catalytic panel with the arrow up.

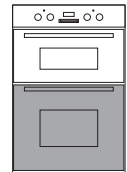

NOTE: Oven bulb replacement is not covered by your guarantee.

Figure 29

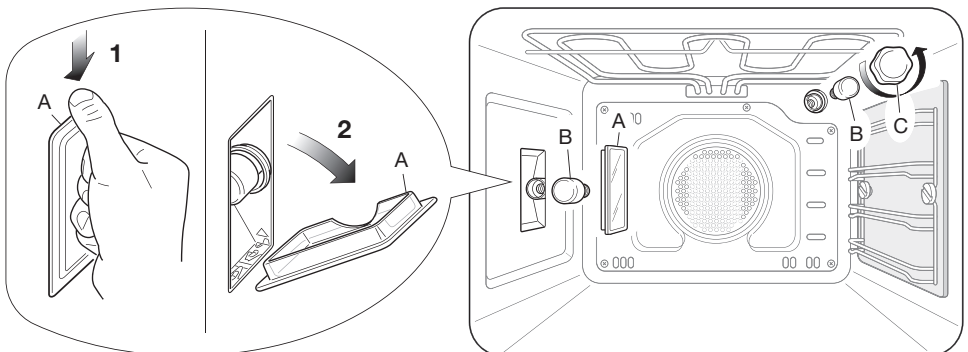

REMOVING THE OVEN DOORS

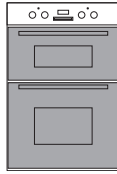

The oven doors can easily be removed as follows:

- Open the door to the full extent (fig. 31).
- Open the lever **A** completely on the left and right hinges (fig. 32).
- Hold the door as shown in fig. 30.
- Gently close the door (fig. 33) until left and right hinge levers **A** are hooked to part **B** of the door (fig. 32).
- Withdraw the hinge hooks from their location following arrow **C** (fig. 34).
- Rest the door on a soft surface.
- To replace the door, repeat the above steps in reverse order.

Figure 31

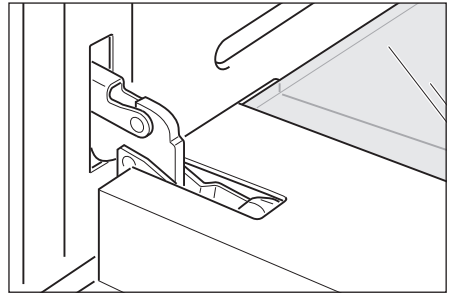

Figure 32

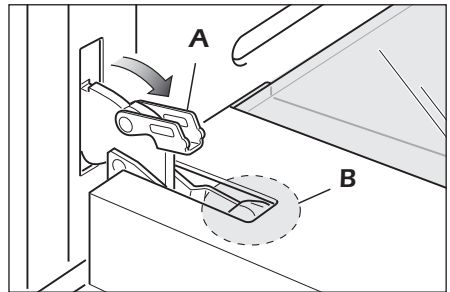

Figure 33

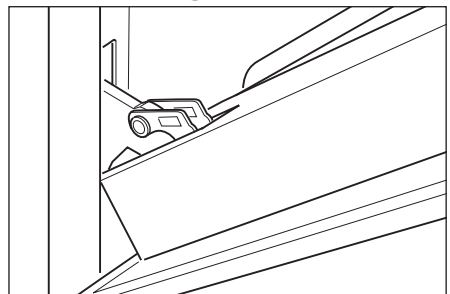

Figure 30

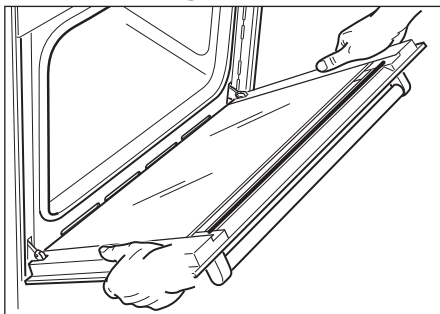

Figure 34

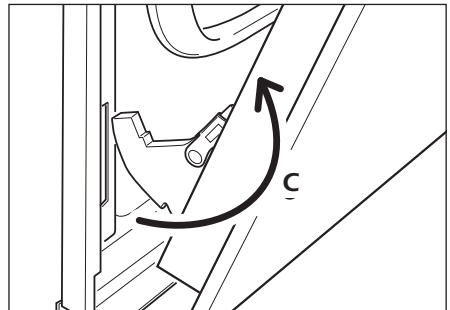

Figure 35

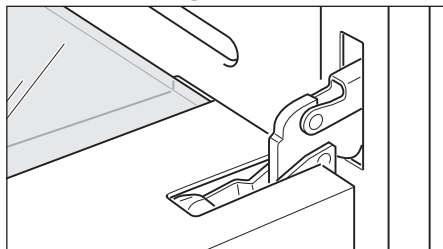

Figure 36

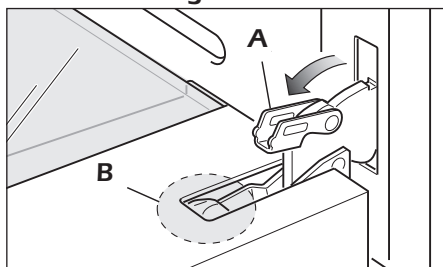

Figure 37

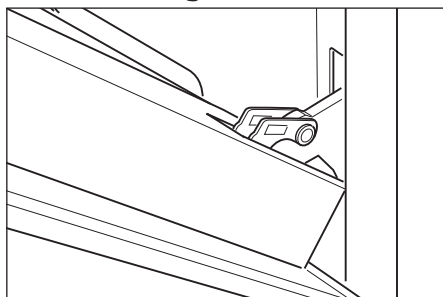
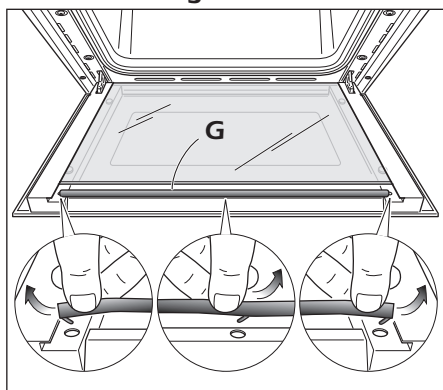
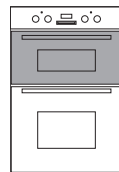

Figure 38



TOP OVEN DOOR (WITH TWO PANES OF GLASS)



CLEANING THE PANES OF GLASS

Do not use harsh abrasive cleaners or sharp metal scrapers to clean the oven door glass since they scratch the surface, which may result in shattering of the glass.

REMOVING THE INNER PANE OF GLASS

The oven door has two panes. To clean these, you need to remove the inner pane.

1. Lock the door open:

- Fully open the oven door (fig. 35).
- Fully open the lever **A** on the left and right hinges. (Fig. 36).
- Gently close the door (Fig. 37) until the left and right hinges are hooked to part **B** of the door (Fig. 36)

2. Remove the inner pane:

- Remove the seal **G** by unhooking the three fixing hooks (Fig. 38).
- Gently pull out the inner pane of glass (Fig. 39)
- Clean the glass with an appropriate cleaner. Dry thoroughly, and place on a soft surface.

Now you can also clean the inside of the outer glass.

Figure 39

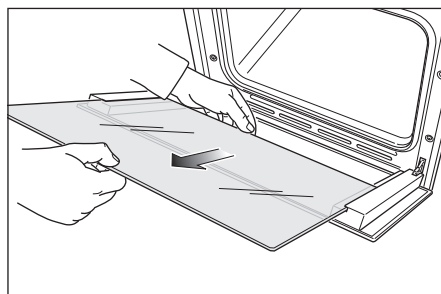

Figure 40

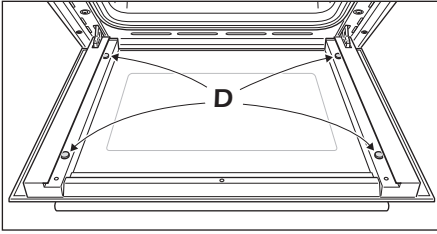

Figure 41

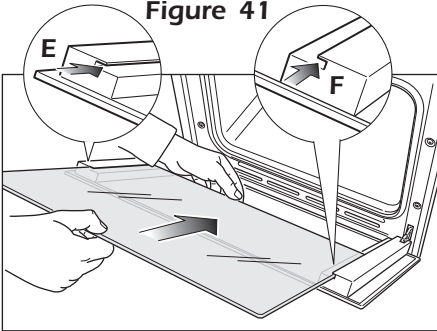

Figure 42

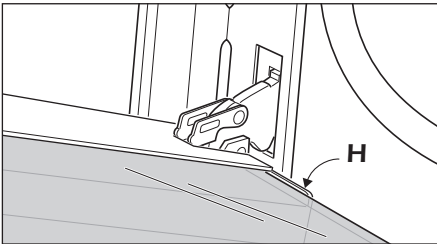

Figure 43

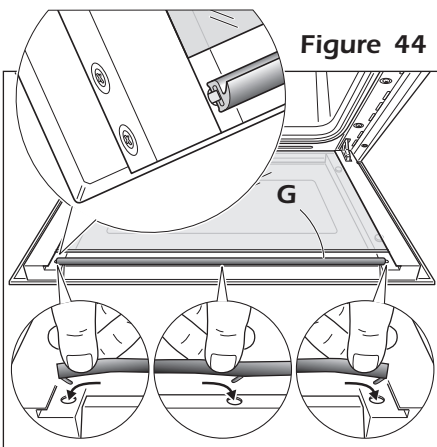

Figure 44

REPLACING THE INNER PANE OF GLASS

1. Make sure the door is locked open (see figs. 35, 36, 37).

2. Replace the inner pane:

- Check that the four rubber pads are in place (D in Fig. 40)
- Check that you are holding the pane the correct way. You should be able to read the wording on it as it faces you.
- Insert the pane in the left E and right F slide guides (fig. 41), and gently slide it to the retainers H (fig. 42).
- Replace the seal G by hooking in the three fixing hooks (fig. 44). Make sure that you put it in the correct way. (Fig. 43).
- Unlock the oven door by opening it completely and closing the lever A on the left and right hinges (Fig. 45),

The top oven door has a sealed gasket in the top part.

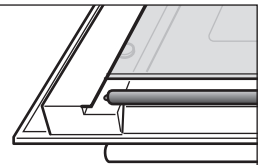

It is normal the opened gap between the top edge of the inner glass and the sealed gasket. This allows the cooling air circulation.

Figure 45

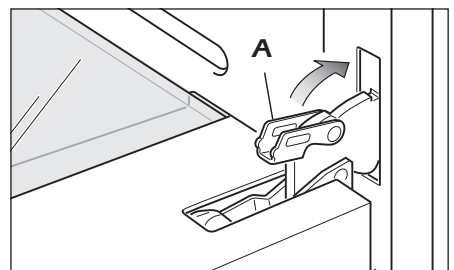

Figure 46

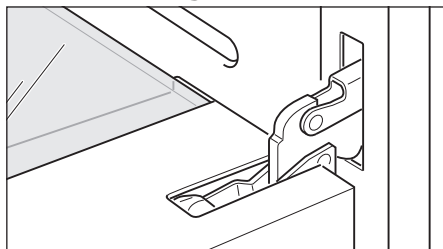

Figure 47

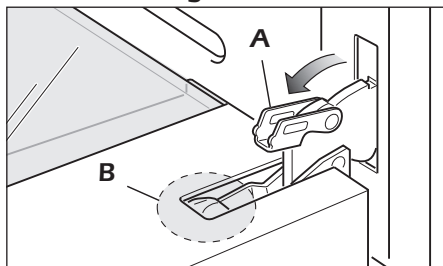

Figure 48

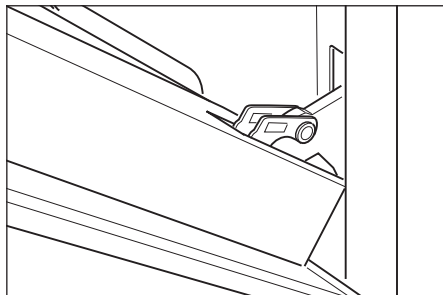
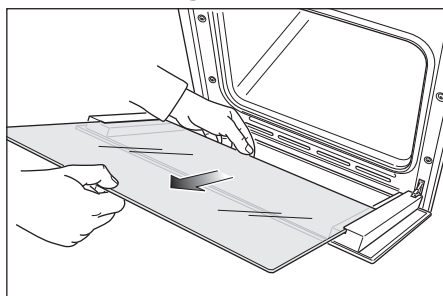

Figure 49



BOTTOM OVEN DOOR (WITH THREE PANES OF GLASS)



CLEANING THE PANES OF GLASS

The oven door is fitted with no. 3 panes:

- no. 1 outside;
- no. 1 inner;
- no. 1 in the middle.

To clean all panes on both sides it is necessary to remove the inner and the middle panes as follows.

Do not use harsh abrasive cleaners or sharp metal scrapers to clean the oven door glass since they scratch the surface, which may result in shattering of the glass.

REMOVING THE MIDDLE AND INNER PANES OF GLASS

- 1. Lock the door open:**
 - Fully open the oven door (fig. 46).
 - Fully open the lever **A** on the left and right hinges. (fig. 47).
 - Gently close the door (fig. 48) until the left and right hinges are hooked to part **B** of the door (fig. 47).
- 2. Remove the inner pane:**
 - Gently pull out the inner pane of glass (fig. 49).
 - Clean the glass with an appropriate cleaner. Dry thoroughly, and place on a soft surface.

Figure 50

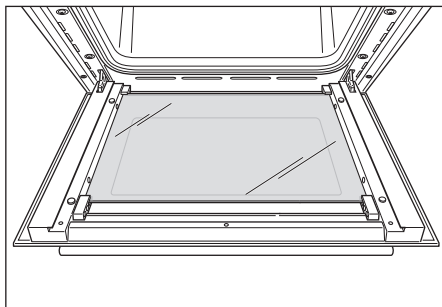

Figure 51

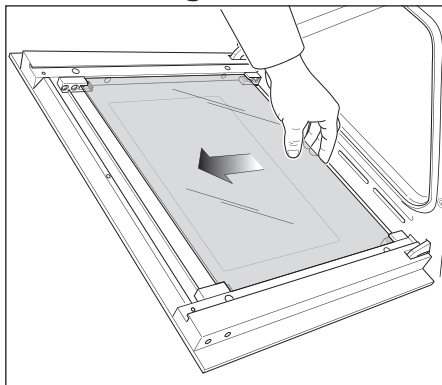
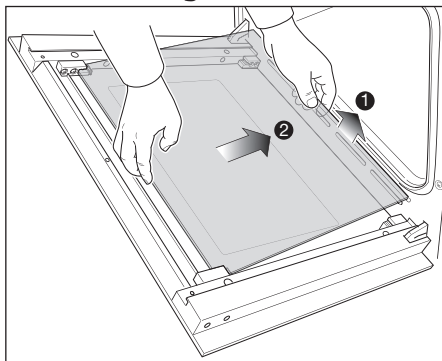

Figure 52



3. Remove the middle pane:

- Gently unlock the middle pane of glass from the bottom clamps by moving it as in fig. 51.
- Gently lift the bottom edge of the pane (arrow 1 in fig. 52) and remove it by pulling it out from the top clamps (arrow 2 in fig. 52).
- Clean the glass with an appropriate cleaner. Dry thoroughly, and place on a soft surface.

Now you can also clean the inside of the outer glass.

Figure 53

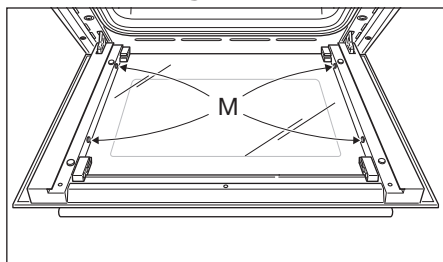

Figure 54

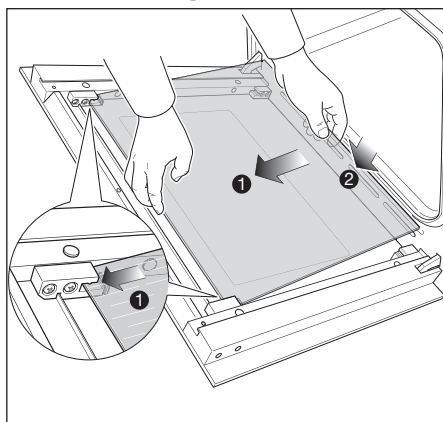
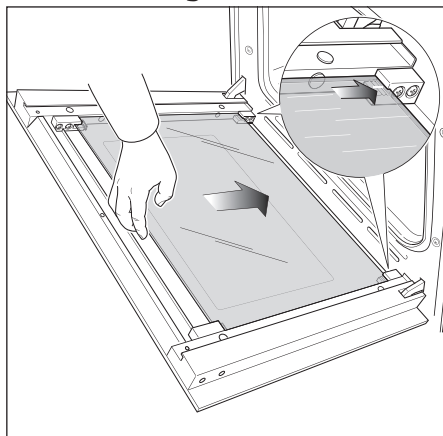

Figure 55



REPLACING THE MIDDLE AND INNER PANES OF GLASS

1. Make sure the door is locked open (see fig. 48).

2. Replace the middle pane:

- Check that the four rubber pads are in place (M in fig. 53).
- Check that you are holding the pane the correct way. You should be able to read the wording on it as it faces you.
- Gently insert the top edge of the pane into the top clamps (arrow 1 in fig. 54), then lower the pane and insert the bottom edge into the bottom clamps (arrow 2 in fig. 54); and then slide the pane into position (fig. 55).

Figure 56

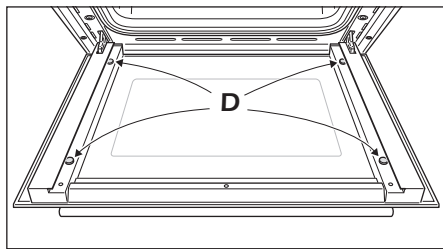

Figure 57

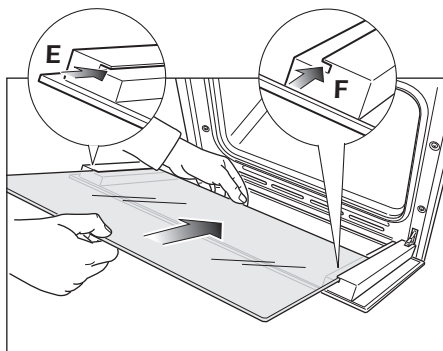

Figure 58

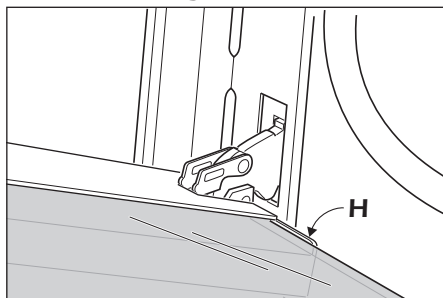
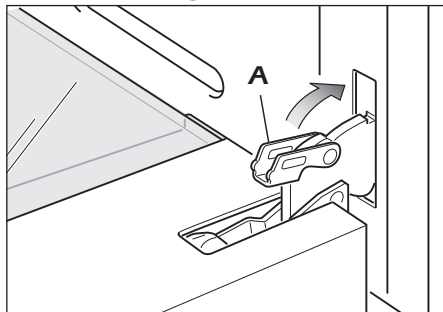

Figure 59



3. Replace the inner pane:

- Check that the four rubber pads are in place (**D** in fig. 56).
- Check that you are holding the pane the correct way. You should be able to read the wording on it as it faces you.
- Insert the pane in the left **E** and right **F** slide guides (fig. 57), and gently slide it to the retainers **H** (Fig. 58).

4. Unlock the oven door by opening it completely and closing the lever **A on the left and right hinges (fig. 59).**

The bottom oven door has not a sealed gasket in the top part.

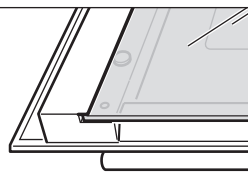

TROUBLESHOOTING:

If you experience a problem with your oven, check the following points before calling our Customer Service Centre for assistance.

1. The power is switched on.
2. The controls are switched on.
3. The electronic timer is set to manual.
4. Both the fuse and the mains fuse are intact.

Should you still require assistance please contact our Customer Service Centre for your nearest Authorised DeLonghi Service Agent.



Living innovation

Cod. 1103682 B2