

SEARS

CRAFTSMAN[®]

MODEL NUMBER 917.372480 OWNER'S MANUAL

2one
Mulcher/Bagger



- Assembly
- Operation
- Customer Responsibilities
- Service
- Adjustments
- Repair Parts

Caution:
Read and Follow
all Safety Rules
and Instructions
Before Operating
This Equipment

SEARS, ROEBUCK AND Co., Chicago, IL. 60684 U.S.A.

SAFETY RULES



CAUTION: ALWAYS DISCONNECT SPARK PLUG WIRE AND PLACE WIRE WHERE IT CANNOT CONTACT SPARK PLUG TO PREVENT ACCIDENTAL STARTING WHEN SETTING UP, TRANSPORTING, ADJUSTING OR MAKING REPAIRS.



IMPORTANT

SAFETY STANDARDS REQUIRE OPERATOR PRESENCE CONTROLS TO MINIMIZE THE RISK OF INJURY. YOUR UNIT IS EQUIPPED WITH SUCH CONTROLS. DO NOT ATTEMPT TO DEFEAT THE FUNCTION OF THE OPERATOR PRESENCE CONTROLS UNDER ANY CIRCUMSTANCES.

TRAINING:

- Read this operator's manual carefully. Become familiar with the controls and know how to operate your mower properly. Learn how to quickly stop mower.
- Do not allow children to use your mower. Never allow adults to use mower without proper instructions.
- Keep the area of operation clear of all persons, especially small children and pets.
- Use mower only as the manufacturer intended and as described in this manual.
- Do not operate mower if it has been dropped or damaged in any manner. Always have damage repaired before using your mower.
- Do not use accessory attachments that are not recommended by the manufacturer. Use of such attachments may be hazardous.
- The blade turns when the engine is running.
- Always stop the engine whenever you leave or are not using your mower, or before crossing driveways, walks, roads, and any gravel-covered areas.
- Never direct discharge of material toward bystanders nor allow anyone near the mower while you are operating it.
- Before cleaning, inspecting, or repairing your mower, stop the engine and make absolutely sure the blade and all moving parts have stopped. Then disconnect the spark plug wire and keep it away from the spark plug to prevent accidental starting.
- Do not continue to run your mower if you hit a foreign object. Follow the procedure outlined above, then repair any damage before restarting and operating you mower.
- Do not change the governor settings or overspeed the engine. Engine damage or personal injury may result.
- Do not operate your mower if it vibrates abnormally. Excessive vibration is an indication of damage; stop the engine, safely check for the cause of vibration and repair as required.
- Do not run the engine indoors. Exhaust fumes are dangerous.
- Never cut grass by pulling the mower towards you. Mow across the face of slopes, never up and down or you might lose your footing. Do not mow excessively steep slopes. Use caution when operating the mower on uneven terrain or when changing directions - maintain good footing.
- Never operate your mower without proper guards, plates, grass catcher or other safety devices in place.

PREPARATION:

- Always thoroughly check the area to be mowed and clear it of all stones, sticks, wires, bones, and other foreign objects. These objects will be thrown by the blade and can cause severe injury.
- Always wear safety glasses or eye shields when starting and while using your mower.
- Dress properly. Do not operate mower when barefoot or wearing open sandals. Wear only solid shoes with good traction when mowing.
- Check fuel tank before starting engine. Do not fill gas tank indoors, when the engine is running or when the engine is hot. Allow the engine to cool for several minutes before filling the gas tank. Clean off any spilled gasoline before starting the engine.
- Always make wheel height adjustments before starting your mower. Never attempt to do this while the engine is running.
- Mow only in daylight or good artificial light.

OPERATION:

- Keep your eyes and mind on your mower and the area being cut. Do not let other interests distract you.
- Do not mow wet or slippery grass. Never run while operating your mower. Always be sure of your footing - keep a firm hold on the handles and walk.
- Do not put hands or feet near or under rotating parts. Keep clear of the discharge opening at all times.

MAINTENANCE AND STORAGE:

- Check the blade and the engine mounting bolts often to be sure they are tightened properly.
- Check all bolts, nuts and screws at frequent intervals for proper tightness to be sure mower is in safe working condition.
- Keep all safety devices in place and working.
- To reduce fire hazard, keep the engine free of grass, leaves or excessive grease and oil.
- Check grass catcher often for deterioration and wear and replace worn bags. Use only replacement bags that are recommended by and comply with specifications of the manufacturer of your mower.
- Always keep a sharp blade on your mower.
- Allow engine to cool before storing in any enclosure.
- Never store mower with fuel in the tank inside a building where fumes may reach an open flame or an ignition source such as a hot water heater, space heater, clothes dryer, etc.



LOOK FOR THIS SYMBOL TO POINT OUT IMPORTANT SAFETY PRECAUTIONS. IT MEANS - ATTENTION!!! BECOME ALERT!!! YOUR SAFETY IS INVOLVED.

CONGRATULATIONS on your purchase of a Sears Craftsman Lawn Mower. It has been designed, engineered and manufactured to give you the best possible dependability and performance.

Should you experience any problems you cannot easily remedy, please contact your nearest Sears Service Center/Department. Sears has competent, well trained technicians and the proper tools to service or repair this unit.

Please read and retain this manual. The instructions will enable you to assemble and maintain your lawn mower properly. Always observe the "SAFETY RULES".

<p>MODEL NUMBER 917.372480</p> <p>SERIAL NUMBER _____</p> <p>DATE OF PURCHASE _____</p> <p>THE MODEL AND SERIAL NUMBERS WILL BE FOUND ON A DECAL ATTACHED TO THE REAR OF THE LAWN MOWER HOUSING.</p> <p>YOU SHOULD RECORD BOTH SERIAL NUMBER AND DATE OF PURCHASE AND KEEP IN A SAFE PLACE FOR FUTURE REFERENCE.</p>
--

PRODUCT SPECIFICATIONS

HORSEPOWER:	5.0
DISPLACEMENT:	12.04 cu. in.
GASOLINE CAPACITY:	1 quart (Unleaded)
OIL (20 oz. Capacity):	SAE 30 (Above 32°F) 5W30 (Below 32°F)
SPARK PLUG (GAP .030 in.): (0.76 mm)	Champion RJ19LM or Sears ^{Z1} 33312 or STD 361458 or STD 360950
VALVE CLEARANCE: Intake:	.008 in.
Exhaust:	.008 in.
SOLID STATE IGNITION AIR GAP:	.0125 in.
BLADE BOLT TORQUE:	35-40 ft.-lbs.

MAINTENANCE AGREEMENT

A Sears Maintenance Agreement is available on this product. Contact your nearest Sears store for details.

CUSTOMER RESPONSIBILITIES

- Read and observe the safety rules.
- Follow a regular schedule in maintaining, caring for and using your lawn mower.
- Follow the instructions under "Customer Responsibilities" and "Storage" sections of this Owner's Manual.

LIMITED TWO YEAR WARRANTY ON CRAFTSMAN POWER MOWER

For two years from date of purchase, when this Craftsman Lawn Mower is maintained, lubricated, and tuned up according to the operating and maintenance instructions in the owner's manual, Sears will repair free of charge any defect in material or workmanship.

If this Craftsman Lawn Mower is used for commercial or rental purposes, this warranty applies for only 90 days from the date of purchase.

This Warranty does not cover:

- Expendable items which become worn during normal use, such as rotary mower blades, blade adapters, belts, air cleaners and spark plug.
- Repairs necessary because of operator abuse or negligence, including bent crankshafts and the failure to maintain the equipment according to the instructions contained in the owner's manual.

WARRANTY SERVICE IS AVAILABLE BY RETURNING THE CRAFTSMAN POWER MOWER TO THE NEAREST SEARS SERVICE CENTER/DEPARTMENT IN THE UNITED STATES. THIS WARRANTY APPLIES ONLY WHILE THIS PRODUCT IS IN USE IN THE UNITED STATES.







This Warranty gives you specific legal rights, and you may also have other rights which vary from state to state.

SEARS, ROEBUCK AND CO., D/731CR-W SEARS TOWER, CHICAGO, IL 60684



LAWN MOWER ACCESSORIES

These accessories were available when this lawn mower was produced. They are also available at most Sears retail outlets, catalog and service centers. Most Sears stores can also order repair parts for you, when you provide the model number of your lawn mower. Some of these accessories may not apply to your lawn mower.

ENGINE

<p>SPARK PLUG</p> 	<p>MUFFLER</p> 	<p>AIR FILTER</p> 	<p>GAS CAN</p> 	<p>ENGINE OIL</p> 	<p>STABILIZER</p> 
--	---	--	--	--	--



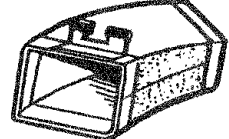
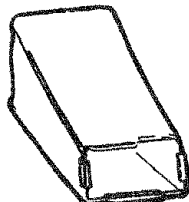
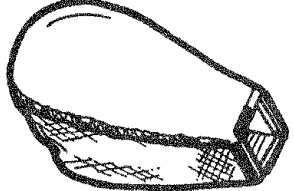

If lawn mower is an electric start

<p>CHARGER</p> 	<p>BATTERY</p> 
--	---

LAWN MOWER PERFORMANCE

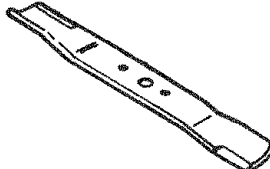
<p>REAR BAG OPTIONAL</p>	<p>DUST SHIELD</p> 	<p>CLIPPING DEFLECTOR</p> 	
<p>REPLACEMENT BAG FOR REAR DISCHARGE LAWN MOWERS</p>	<p>FABRIC BAG</p> 	<p>OPTIONAL CATCHER FOR SIDE DISCHARGE LAWN MOWER</p>	<p>SIDE DISCHARGE CATCHER</p> 

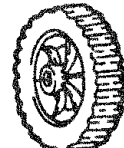
LAWN MOWER MAINTENANCE

<p>BELT</p> 	<p>BLADE</p> 	<p>BLADE ADAPTER</p> 	<p>WHEELS</p> 	<p>LAWN MOWER COVER</p> 
--	---	---	--	--

ASSEMBLY

Your lawn mower has been assembled at the factory except for the grass catcher bag and the grass catcher frame.

TO REMOVE LAWN MOWER FROM CARTON

- Remove loose parts included with mower.
- Cut down two end corners of carton and lay end panel down flat.
- Remove all packing materials except padding between upper and lower handle and padding holding operator presence control bar to upper handle.
- Roll lawn mower out of carton and check carton thoroughly for additional loose parts.

HOW TO SET UP YOUR LAWN MOWER

TO UNFOLD HANDLE (See Fig. 1)

- Raise handles until lower handle section locks into place in mowing position.
- Raise upper handle section into place on lower handle, remove protective padding and tighten both handle knobs.
- Remove handle padding holding operator presence control bar to upper handle.
- Your lawn mower handle can be adjusted for your mowing comfort. Refer to "Adjust Handle" in the Service and Adjustment section of this manual.

TO ASSEMBLE GRASS CATCHER (See Fig. 2)

- Put grass catcher frame into grass bag with stiff part of bag on the bottom.
- Slip vinyl bindings over frame.

NOTE: If vinyl bindings are too stiff, hold them in warm water for a few minutes. If bag gets wet, let it dry before using.

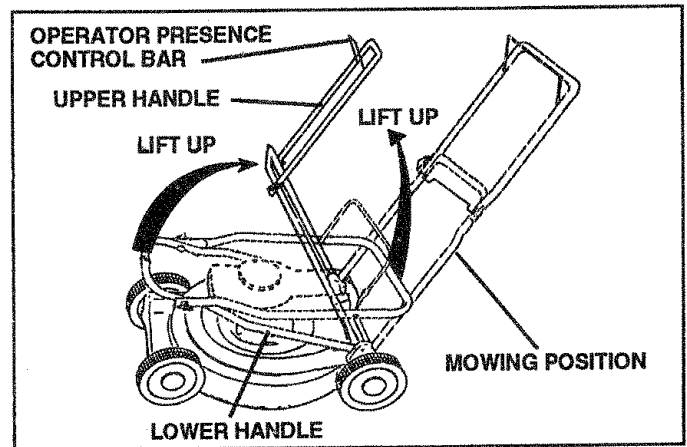

FIG. 1

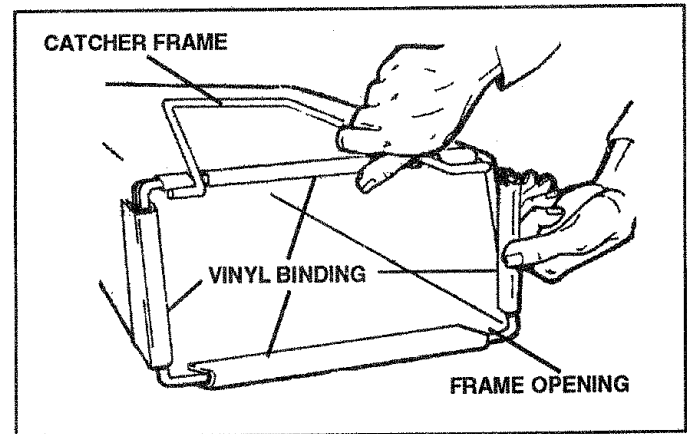

FIG. 2

OPERATION

KNOW YOUR LAWN MOWER

READ THIS OWNER'S MANUAL AND SAFETY RULES BEFORE OPERATING YOUR LAWN MOWER. Compare the illustrations with your lawn mower to familiarize yourself with the location of various controls and adjustments. Save this manual for future reference.

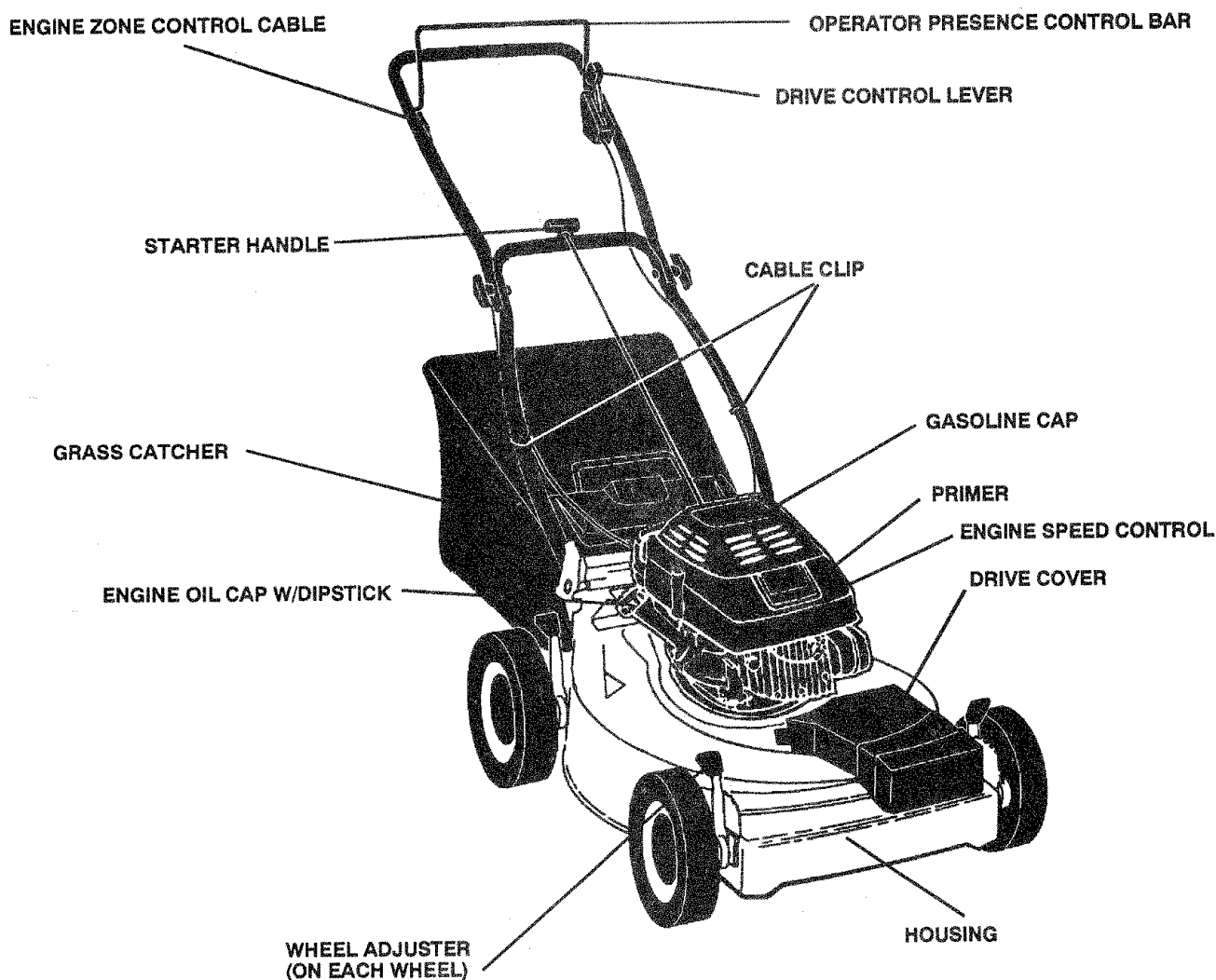

FIG. 3

MEETS CPSC SAFETY REQUIREMENTS

Sears rotary walk-behind power lawn mowers conform to the safety standards of the American National Standards Institute and the U.S. Consumer Product Safety Commission. The blade turns when the engine is running.

OPERATOR PRESENCE CONTROL - must be held down to the handle to start the engine. Release to stop the engine.

PRIMER - pumps additional fuel from the carburetor to the cylinder for use when starting a cold engine.

STARTER HANDLE - used for starting the engine.

DRIVE CONTROL LEVER - used to engage power-propelled forward motion of lawn mower.

ENGINE SPEED CONTROL - located on the side of the engine which allows you to select either "HIGH" (↻) or "LOW" (↻) engine speed.

OPERATION

HOW TO USE YOUR LAWN MOWER



CAUTION: Do not run your lawn mower without mulcher plate in place and door closed or without an approved clipping deflector or grasscatcher in place. Never attempt to operate the lawn mower with the rear door removed or propped open.

ENGINE SPEED (See Fig. 4)

The engine speed is controlled by a lever (red knob) located on the side of the engine. "HIGH" (☛) position is for starting the engine, normal cutting, and better grass bagging. "LOW" (☚) position is for light cutting, trimming and fuel economy.

ENGINE ZONE CONTROL



CAUTION: Federal regulations require an engine control to be installed on this lawn mower in order to minimize the risk of blade contact injury. Do not under any circumstances attempt to defeat the function of the operator control. The blade turns when the engine is running.

- Your lawn mower is equipped with an operator presence control bar which requires the operator to be positioned behind the lawn mower handle to start and operate the lawn mower.

TO INSTALL ATTACHMENTS (See Figs. 5 & 6)

Your lawn mower was shipped ready to be used as a mulcher. To install attachments for bagging or discharging:

- Open rear door and remove mulcher plate.
- You can now install catcher or optional clipping deflector.
- To return to mulching operation reverse the above steps. **BE SURE MULCHER PLATE IS INSTALLED BEFORE USING FOR MULCHING OPERATION.**

TO INSTALL GRASS CATCHER (See Fig. 7)

- Lift the rear door on the lawn mower housing and place the grass catcher frame onto the formed up tabs on the rear door hinge bracket.
- The grass catcher is secured to the lawn mower when the rear door is lowered onto the grass catcher frame.

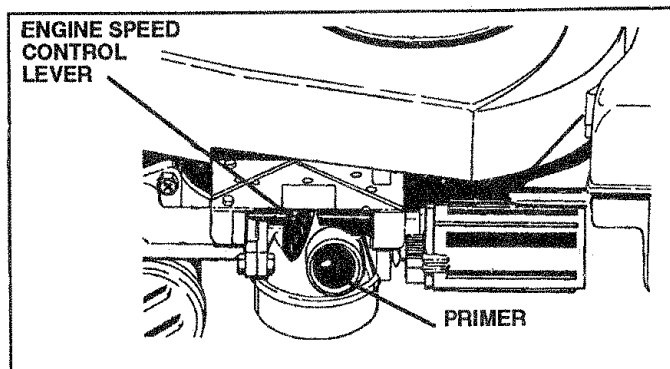

FIG. 4

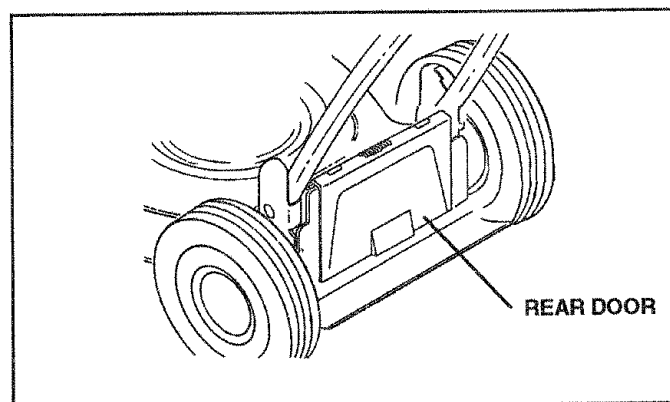

FIG. 5

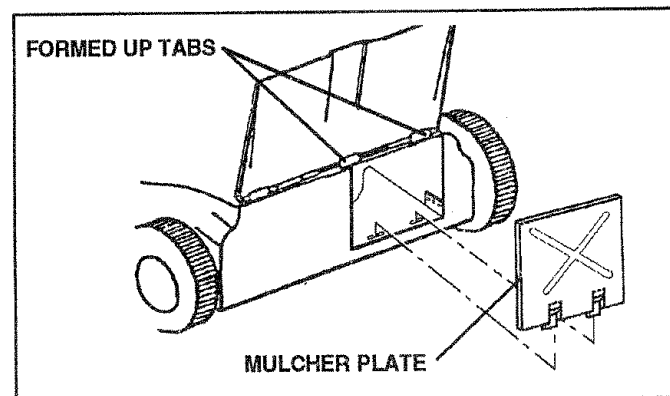

FIG. 6

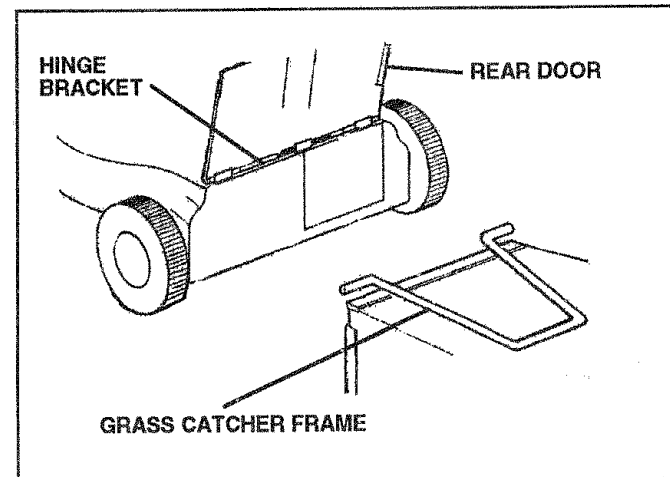

FIG. 7

OPERATION

TO EMPTY GRASS CATCHER (See Fig. 8)

- To remove grass catcher, release operator presence control bar to stop engine.
- Lift up rear door and remove the grass catcher by the handle.
- Do not drag the bag when emptying; it will cause unnecessary wear.

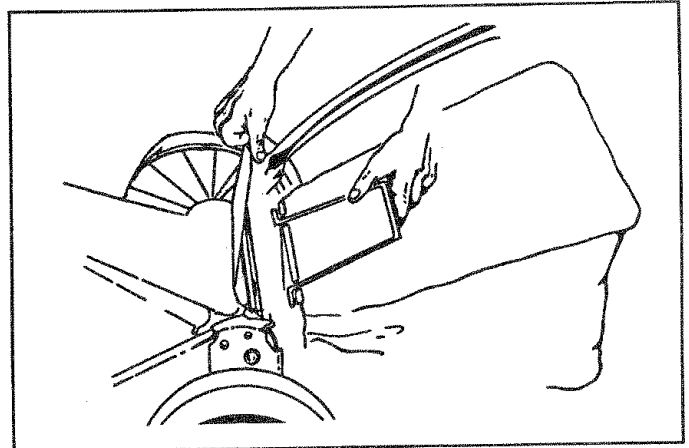

FIG. 8

DRIVE CONTROL (See Fig. 9)

- Self-propelling is controlled by holding the operator presence control bar down to the handle and pushing the drive control lever forward until it clicks; then release the lever.
- Forward motion will stop when the operator presence control bar is released. To stop forward motion without stopping engine, release the operator presence control bar slightly until the drive control disengages. Hold operator presence control bar down to handle to continue mowing without self-propelling.
- To keep drive control engaged when turning corners, push down on handle and lift front wheels off ground while turning lawn mower.

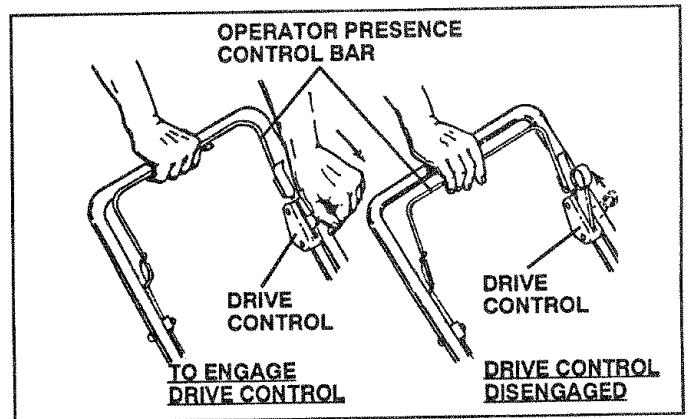

FIG. 9

TO ADJUST CUTTING HEIGHT (See Fig. 10)

- Raise wheels for low cut and lower wheels for high cut.
- Wheels are set in low cut for shipping. Adjust cutting height to suit your requirements. Medium position is best for most lawns.
- To change cutting height, squeeze adjuster lever toward wheel. Move wheel up or down to suit your requirements. Be sure all wheels are in the same setting.

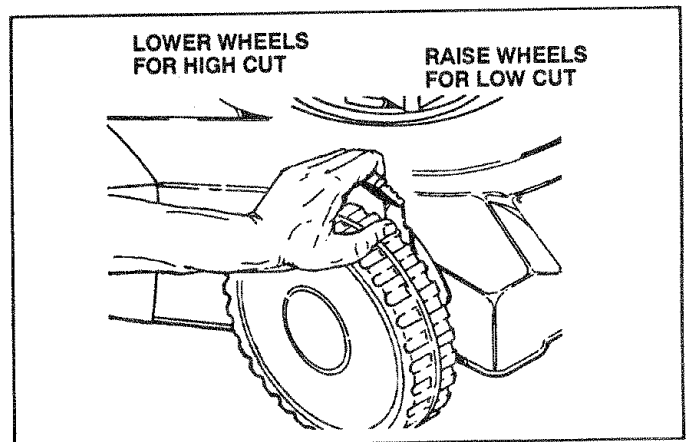

FIG. 10

OPERATION

BEFORE STARTING ENGINE

OIL (See Fig. 11)

A 20 oz. bottle of Pennzoil SAE 30 oil is included with your new lawn mower.

- Remove engine oil cap and fill to the FULL line on the dipstick.
- Use 20 ozs. of oil. For type and grade of oil to use, see "ENGINE" in Customer Responsibilities section of this manual.
- **POUR OIL SLOWLY. DO NOT OVER FILL.**
- Check oil level before each use. Add oil if needed. Fill to FULL line on dipstick.
- To read proper level, tighten engine oil cap each time.
- Reinstall engine oil cap and tighten.
- After the first two (2) hours of mowing, change the oil, and every 25 hours thereafter. You may need to change the oil more often under dusty, dirty conditions.

GAS (See Fig. 11)

- Fill gasoline tank with fresh, clean unleaded gasoline. **DO NOT USE PREMIUM GASOLINE. BE CAREFUL NOT TO OVER FILL TANK.**

WARNING: Experience indicates that alcohol blended fuels (called gasohol or using ethanol or methanol) can attract moisture which leads to separation and formation of acids during storage. Acidic gas can damage the fuel system of an engine while in storage.

To avoid engine problems, the fuel system should be emptied before storage for 30 days or longer. Drain the gas tank, start the engine and let it run until the fuel lines and carburetor are empty. Use fresh fuel next season. See Storage instructions for additional information.

Never use engine or carburetor cleaner products in the fuel tank or permanent damage may occur.

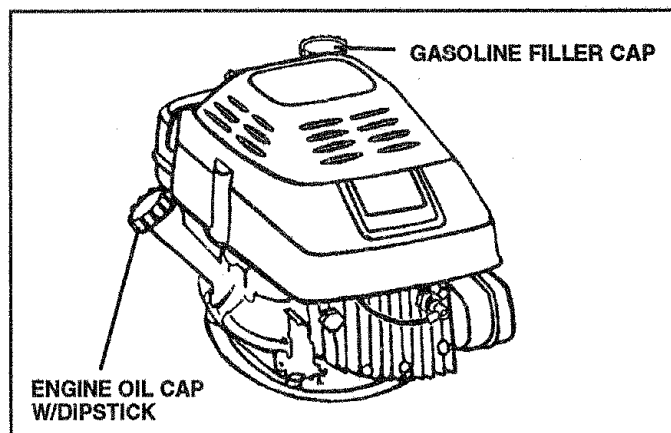

FIG. 11

TO START ENGINE

- To start a cold engine, push primer five (5) times before trying to start. Use a firm push. This step is not usually necessary when starting an engine which has already run for a few minutes.
- Push engine speed control lever to HIGH (H) position.
- Hold operator presence control bar down to the handle and pull starter handle quickly. **DO NOT** allow starter rope to snap back.
- To "STOP" engine, release operator presence control bar.

NOTE: In cooler weather it may be necessary to repeat priming steps. In warmer weather over priming may cause flooding and engine will not start. If you do flood engine, wait a few minutes before attempting to start and **DO NOT** repeat priming steps.

OPERATION

MOWING TIPS

- Under certain conditions, such as very tall grass, it may be necessary to raise the height of cut to reduce pushing effort and to keep from overloading the engine and leaving clumps of grass clippings.
- For extremely heavy cutting, reduce the width of cut and raise the rear of the lawn mower housing one (1) wheel adjuster setting higher than the front for better discharge of grass.
- For better grass bagging and most cutting conditions, the engine speed should be set in the "HIGH" (⚡) (FAST) position.
- When using a rear discharge lawn mower in moist, heavy grass, clumps of cut grass may not enter the grass catcher. Reduce ground speed (pushing speed) and/or run the lawn mower over the area a second time.
- If a trail of grass clippings is left on the right side of a rear discharge lawn mower, mow in a clockwise direction with a small overlap to collect the clippings on the next pass.
- Keep top of engine around starter clear and clean of grass clippings and chaff. This will help engine air flow and extend engine life.
- Pores in cloth grass catchers can become filled with dirt and dust with use and catchers will collect less grass. To prevent this, regularly hose catchers off with water and let dry before using.

MULCHING MOWING TIPS

IMPORTANT: FOR BEST PERFORMANCE, KEEP MOWER HOUSING FREE OF BUILT-UP GRASS AND TRASH. CLEAN AFTER EACH USE. SEE "CLEANING" IN CUSTOMER RESPONSIBILITIES SECTION OF THIS MANUAL.

- The special mulching blade will recut the grass clippings many times and reduce them in size so that as they fall onto the lawn they will disperse into the grass and not be noticed. Also, the mulched grass will biodegrade quickly to provide nutrients for the lawn. Always mulch with your highest engine (blade) speed as this will provide the best recutting action of the blades.

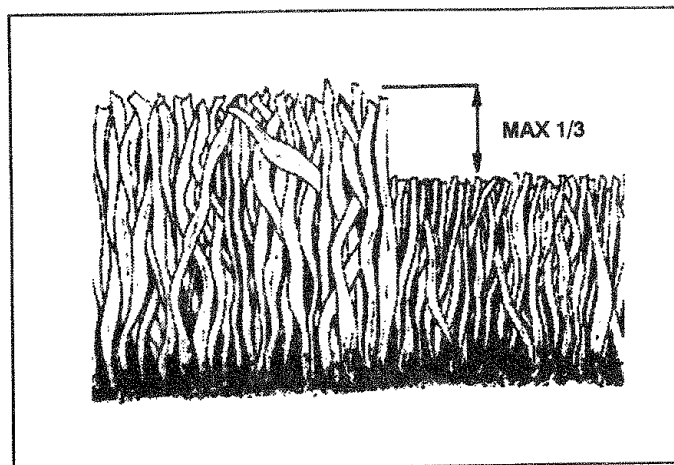

FIG. 12

- Avoid cutting your lawn when it is wet. Wet grass tends to form clumps and interferes with the mulching action. The best time to mow your lawn is the early afternoon. At this time the grass has dried and the newly cut area will not be exposed to the direct sun.
- For best results, adjust the lawn mower cutting height so that the lawn mower cuts off only the top one-third of the grass blades (See Fig. 12). If the lawn is overgrown it will be necessary to raise the height of cut to reduce pushing effort and to keep from overloading the engine and leaving clumps of mulched grass. For extremely heavy mulching, reduce your width of cut, mow slowly and raise the rear of the lawn mower one wheel adjuster setting higher than the front.
- Certain types of grass and grass conditions may require that an area be mulched a second time to completely hide the clippings. When doing a second cut, mow across or perpendicular to the first cut path.
- Change your cutting pattern from week to week. Mow north to south one week then change to east to west the next week. This will help prevent matting and graining of the lawn.

CUSTOMER RESPONSIBILITIES

MAINTENANCE SCHEDULE		SERVICE FREQUENCIES						SERVICE DATES					
		BEFORE EACH USE	AFTER EACH USE	FIRST 2 HOURS	EVERY 10 HOURS	EVERY 25 HOURS	BEFORE STORAGE						
MOWER	Check for Loose Fasteners	✓											
	Clean/Inspect Grass Catcher	✓	✓										
	Clean Lawn Mower		✓										
	Inspect Mower Blade				✓								
	Replace/Sharpen Mower Blade					✓ ³							
	Lubricate Pivot Points					✓							
ENGINE	Check Engine Oil Level	✓											
	Change Engine Oil		✓			✓ ^{1,2}							
	Inspect Muffler					✓							
	Replace Spark Plug						✓						
	Replace Air Filter Paper Cartridge						✓ ^{1,2}						

- 1 - Change more often when operating under a heavy load or in high ambient temperatures.
- 2 - Service more often when operating in dirty or dusty conditions.
- 3 - Replace blades more often when mowing in sandy soil.

GENERAL RECOMMENDATIONS

The warranty on this lawn mower does not cover items that have been subjected to operator abuse or negligence. To receive full value from the warranty, operator must maintain mower as instructed in this manual.

Some adjustments will need to be made periodically to properly maintain your unit.

All adjustments in the Service and Adjustments section of this manual should be checked at least once each season.

- Once a year, replace the spark plug, replace air filter element and check blade for wear. A new spark plug and clean/new air filter element assures proper air-fuel mixture and helps your engine run better and last longer.
- Follow the maintenance schedule in this manual.

BEFORE EACH USE

- Check engine oil level.
- Check for loose fasteners.

LUBRICATION

Keep unit well lubricated (See "LUBRICATION CHART").

LUBRICATION CHART

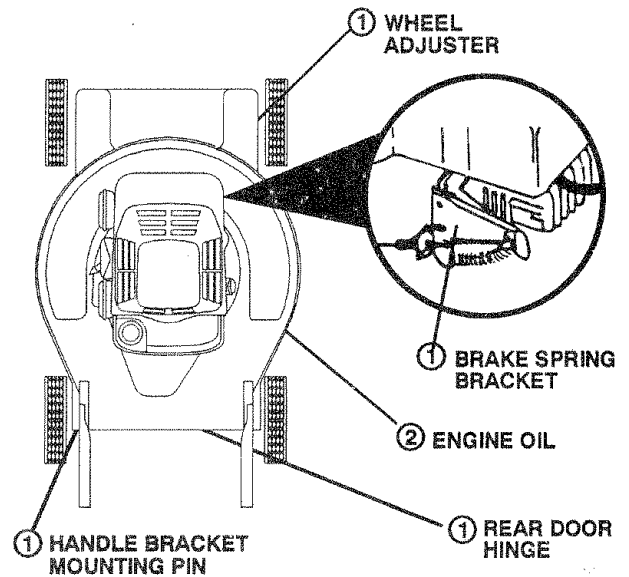

- ① SPRAY LUBRICANT
- ② SAE 30 MOTOR OIL. REFER TO ENGINE - CUSTOMER RESPONSIBILITIES SECTION.

IMPORTANT: DO NOT OIL OR GREASE PLASTIC WHEEL BEARINGS. VISCOUS LUBRICANTS WILL ATTRACT DUST AND DIRT THAT WILL SHORTEN THE LIFE OF THE SELF LUBRICATING BEARINGS. IF YOU FEEL THEY MUST BE LUBRICATED, USE ONLY A DRY, POWDERED GRAPHITE TYPE LUBRICANT SPARINGLY.

CUSTOMER RESPONSIBILITIES

LAWN MOWER

Always observe safety rules when performing any maintenance.

TIRES

- Keep tires free of gasoline, oil, or insect control chemicals which can harm rubber.
- Avoid stumps, stones, deep ruts, sharp objects and other hazards that may cause tire damage.

BLADE CARE

For best results, mower blade must be kept sharp. Replace bent or damaged blades.

TO REMOVE BLADE (See Fig. 13)

- Remove spark plug wire from spark plug and place wire where it cannot come in contact with spark plug.
- Turn lawn mower on its side. Make sure air filter and carburetor are up.
- Use a wood block between blade and mower housing to prevent blade from turning when removing blade bolt.
- Protect your hands with gloves and/or wrap blade with heavy cloth.
- Remove blade bolt by turning counter-clockwise. Use a 9/16" box or open-end wrench.
- Remove blade and attaching hardware (bolt, lock washer and hardened washer).

NOTE: Remove the blade adapter and check the key inside hub of blade adapter. The key must be in good condition to work properly. Replace adapter if damaged.

TO REPLACE BLADE (See Fig. 13)

- Position the blade adapter on the engine crankshaft. Be sure key in adapter and keyway in crankshaft are aligned.
- Position blade on the blade adapter aligning the two (2) holes in the blade with the raised lugs on the adapter.
- Be sure the word TOP (stamped on the blade) is toward the engine.
- Install the blade bolt with the lock washer and hardened washer into blade adapter and crankshaft.
- Use block of wood between blade and lawn mower housing and tighten the blade bolt, turning clockwise.
- The recommended tightening torque is 35-40 ft. lbs.

IMPORTANT: BLADE BOLT IS GRADE 8 HEAT TREATED.



CAUTION: A loose blade can be dangerous.

Use only Sears authorized replacement blade to get the best cutting results.

NOTE: We do not recommend sharpening blade - but if you do, be sure the blade is balanced.

TO SHARPEN BLADE

- The blade can be sharpened with a file or on a grinding wheel. Do not attempt to sharpen while on the mower.
- To check blade balance, drive a nail into a beam or wall. Leave about one inch of the straight nail exposed. Place center hole of blade over the head of the nail. If blade is balanced, it should remain in a horizontal position. If either end of the blade moves downward, sharpen the heavy end until the blade is balanced.

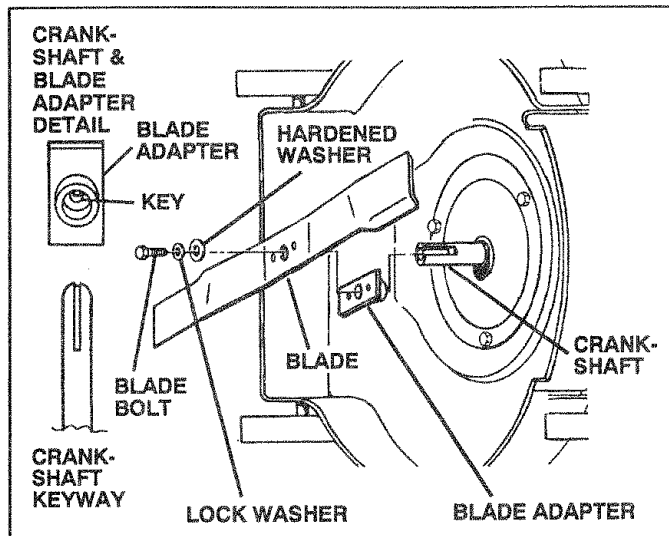

FIG. 13

GEAR CASE

- To keep your drive system working properly, the gear case and area around the drive should be kept clean and free of trash build-up. Clean under the drive cover twice a season.
- The gear case is filled with lubricant to the proper level at the factory. The only time the lubricant needs attention is if service has been performed on the gear case.
- If lubricant is required, use only Texaco Starplex Premium Grease, part no. 750355. Do not substitute.

DRIVE WHEELS

Check front drive wheels each time before you mow to be sure they move freely.

The wheels not turning freely means trash, grass cuttings, etc. are in the drive wheel area and must be cleaned to free drive wheels.

If necessary to clean the drive wheels, check both front wheels.

- Remove hubcaps, hairpin cotters and washers.
- Remove wheels from wheel adjusters.
- Remove any trash or grass cuttings from inside the dust cover, pinion and/or drive wheel gear teeth.
- Put wheels back in place.
- If after cleaning, the drive wheels do not turn freely, contact your nearest Sears Service Center.

GRASS CATCHER

- The grass catcher may be hosed with water, but must be dry when used.
- Check your grass catcher often for damage or deterioration. Through normal use it will wear. If catcher needs replacing, replace only with a manufacturer approved replacement catcher from Sears. Give the lawn mower model number when ordering.

CUSTOMER RESPONSIBILITIES

ENGINE LUBRICATION

Use only high quality detergent oil rated with API service classification SG. Select the oil's SAE viscosity grade according to your expected operating temperature.

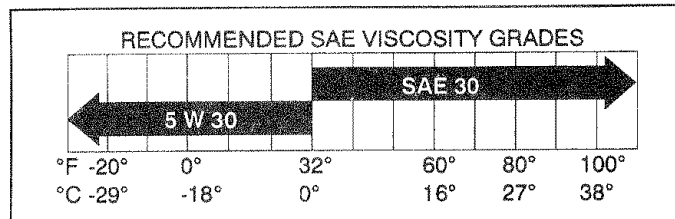

NOTE: Although multi-viscosity oils (5W30, 10W30 etc.) improve starting in cold weather, these multi-viscosity oils will result in increased oil consumption when used above 32°F. Check your engine oil level more frequently to avoid possible engine damage from running low on oil.

Change the oil after the first two hours of operation and every 25 hours thereafter or at least once a year if the lawn mower is not used for 25 hours in one year.

Check the crankcase oil level before starting the engine and after each five (5) hours of continuous use. Tighten oil plug securely each time you check the oil level.

TO CHANGE ENGINE OIL (See Fig. 14)

- Disconnect spark plug wire from spark plug.
- Remove engine oil cap; lay aside on a clean surface.
- Tip lawn mower on its side and drain oil into a suitable container. Rock lawn mower back and forth to remove any oil trapped inside of engine.
- Wipe off any spilled oil on lawn mower and on side of engine.
- Fill engine with SAE 30 or 10W 30 oil. All oil must meet API service classification SG. Fill only to the "FULL" line on the dipstick. **DO NOT OVER FILL.**
- Replace engine oil cap.
- Reconnect spark plug wire to spark plug.

AIR FILTER

Your engine will not run properly and may be damaged by using a dirty air filter.

Replace the air filter every year, more often if you mow in very dusty, dirty conditions. Do not wash air filter.

TO CHANGE AIR FILTER (See Fig. 15)

- Remove the air filter cover by turning counterclockwise to the stop and pull away from collar.
- Remove filter from inside of cover.
- Clean the inside of the cover and the collar to remove any dirt accumulation.
- Insert new filter into cover.
- Put air filter cover and filter into collar aligning the tab with the slot.
- Push in on cover and turn clockwise to tighten.

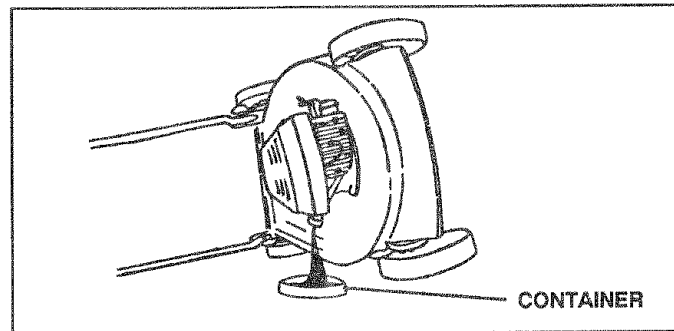

FIG. 14

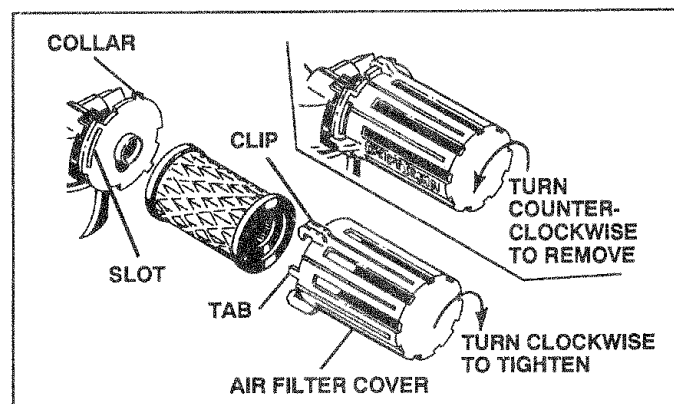

FIG. 15

MUFFLER

Inspect and replace corroded muffler as it could create a fire hazard and/or damage.

SPARK PLUG

Change your spark plug each year to make your engine start easier and run better. Set spark plug gap at .030 inch.

CLEANING

IMPORTANT: FOR BEST PERFORMANCE, KEEP MOWER HOUSING FREE OF BUILT-UP GRASS AND TRASH. CLEAN UNDERSIDE OF MOWER HOUSING AFTER EACH USE.



CAUTION: Disconnect spark plug wire from spark plug and place wire where it cannot come in contact with the spark plug.

- Turn lawn mower on its side. Make sure air filter and carburetor are up. Clean the underside of your lawn mower by scraping to remove build-up of grass and trash.
- Clean engine often to keep trash from accumulating. A clogged engine runs hotter and shortens engine life.
- Keep finished surfaces and wheels free of all gasoline, oil, etc.
- We **DO NOT** recommend using a garden hose to clean lawn mower unless the electrical system, muffler, air filter and carburetor are covered to keep water out. Water in engine can result in shortened engine life.

CLEAN UNDER DRIVE COVER

Clean under drive cover at least twice a season. Scrape underside of cover with putty knife or similar tool to remove any build-up of trash or grass on underside of drive cover.

SERVICE AND ADJUSTMENTS



CAUTION: BEFORE PERFORMING ANY SERVICE OR ADJUSTMENTS:

- Release control bar.
- Make sure the blade and all moving parts have completely stopped.
- Disconnect spark plug wire from spark plug and place where it cannot come in contact with plug.

LAWN MOWER

TO ADJUST CUTTING HEIGHT

See "TO ADJUST CUTTING HEIGHT" in the Operation section of this manual.

DISCHARGE GUARD

The discharge guard, attached to the discharge opening of your lawn mower, is provided to prevent the possibility of injury resulting from objects being thrown out of the discharge opening into the operator mowing position. If the discharge guard becomes damaged, it should be replaced.

TO REMOVE/REPLACE DRIVE BELT

(See Fig. 16)

- Remove drive cover. Remove belt by pushing down on gear case pulley.
- Turn lawn mower on its side with carburetor and fuel cap up.
- Remove blade.
- Remove debris shield.
- Remove belt from engine pulley on crankshaft.
- Install new belt by reversing above steps.
- Always use factory approved belt to assure fit and long life.

TO ADJUST DRIVE CONTROL CABLE

(See Fig. 17)

A drive control cable that needs adjustment will keep your lawn mower from self-propelling properly and can also cause gear case components to wear out sooner.

- Remove drive cover.
- Loosen cable clamp screw "A" and nuts "B" and "C".
- Hold down operator presence control bar to handle and engage drive control.
- Move shifter arm to drive position while rotating front wheels to be sure jaw clutch is engaged. Pull threaded sleeve with pliers. Do not pull on control cable.
- Tighten nut "C" until sleeve is snug.
- Tighten screw "A" and nut "B".
- Push lawn mower back and forth to be sure gear case is engaged.
- Replace drive cover.
- Release operator presence control bar.

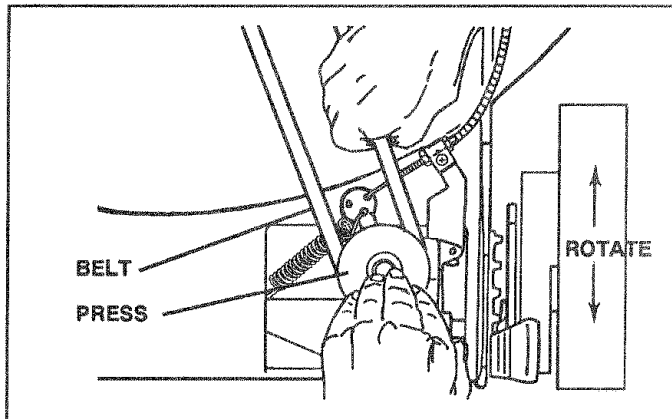

FIG. 16

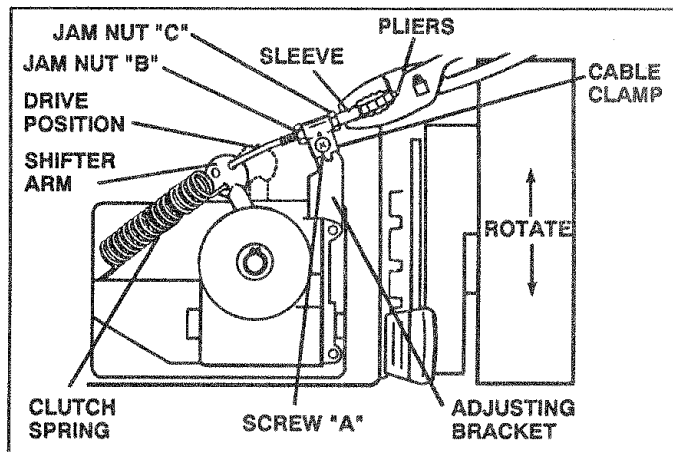

FIG. 17

REAR DEFLECTOR

The rear deflector, attached between the rear wheels of your lawn mower, is provided to minimize the possibility that objects will be thrown out the rear of the lawn mower into the operator's mowing position.

If the rear deflector becomes damaged, it should be replaced.

SERVICE AND ADJUSTMENTS

TO ADJUST HANDLE (See Figs. 18 Thru 20)

Your lawn mower handle can be raised or lowered for your mowing comfort. Four (4) positions are available: high, medium high, medium low and low. Handles are shipped mounted in the medium low position.

- To change from medium low to medium high position, the upper and lower handle sections will have to be turned over (See Fig. 18B).
- Remove the controls and operator presence control bar from the upper handle.
- Remove the starter rope guide from the lower handle.
- Remove hairpin cotters.
- Disconnect the lower handle from the handle brackets (See Fig. 20).
- Turn the handle over and reassemble the hairpin cotters that have been removed.
- Reassemble the starter rope guide.
- Reassemble the controls and the operator presence control bar to the upper handle.



CAUTION: The operator presence control bar must pivot freely to permit blade brake engagement when control bar is released. Do not over tighten the fasteners holding the controls to the upper handle.

- To change from medium low to high position only the upper handle section will have to be turned over (See Fig. 19A).
- To change from medium low to low position, only the lower handle section will have to be turned over (See Fig. 19B).

ENGINE

ENGINE SPEED

Your engine speed has been factory set. Do not attempt to increase engine speed or it may result in personal injury. If you believe that the engine is running too fast or too slow, take your lawn mower to an authorized Sears Service Center for repair and adjustment.

CARBURETOR

Your carburetor has a non-adjustable fixed main jet for mixture control. If your engine does not operate properly due to suspected carburetor problems, take your lawn mower to an authorized Sears Service Center for repair and adjustment.

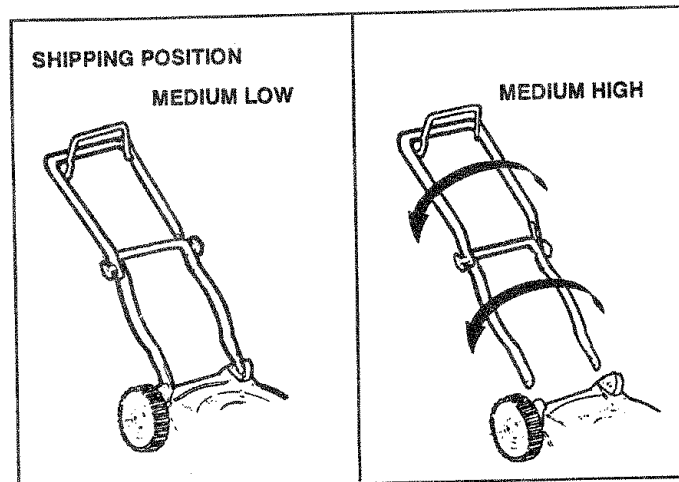

FIG. 18A

FIG. 18B

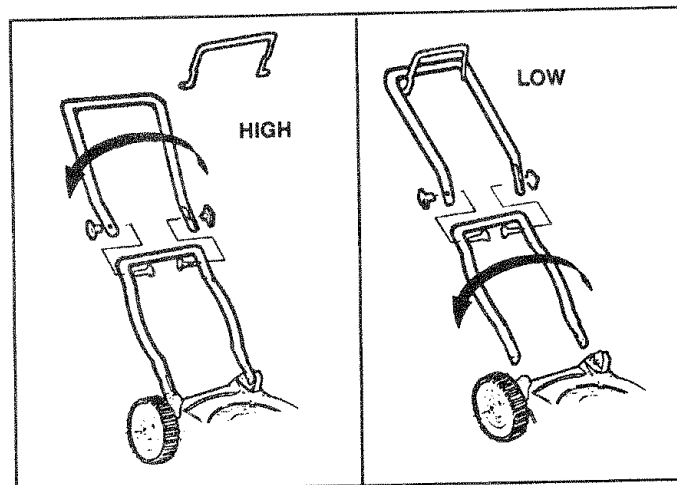

FIG. 19A

FIG. 19B

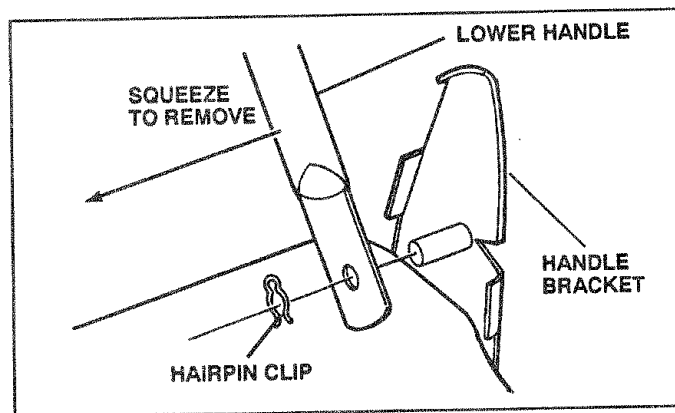

FIG. 20

STORAGE

Immediately prepare your lawn mower for storage at the end of the season or if the unit will not be used for 30 days or more.

LAWN MOWER

When lawn mower is to be stored for a period of time, clean it thoroughly, remove all dirt, grease, leaves, etc. Store in a clean, dry area.

- Clean entire lawn mower (See "CLEANING" in the Customer Responsibilities section of this manual).
- Lubricate as shown in the Customer Responsibilities section of this manual.
- Be sure that all nuts, bolts, screws, and pins are securely fastened. Inspect moving parts for damage, breakage and wear. Replace if necessary.
- Touch up all rusted or chipped paint surfaces; sand lightly before painting.

HANDLE (See Fig. 21)

You can fold your lawn mower handle for storage.

- Squeeze the bottom ends of the lower handle toward each other until the lower handle clears the handle bracket, then move handle forward.
- Loosen upper handle mounting bolts enough to allow upper handle to be folded back.

IMPORTANT: WHEN FOLDING THE HANDLE FOR STORAGE OR TRANSPORTATION, BE SURE TO FOLD THE HANDLE AS SHOWN OR YOU MAY DAMAGE THE CONTROL CABLES.

- When setting up your handle from the storage position, the lower handle will automatically lock into the mowing position.

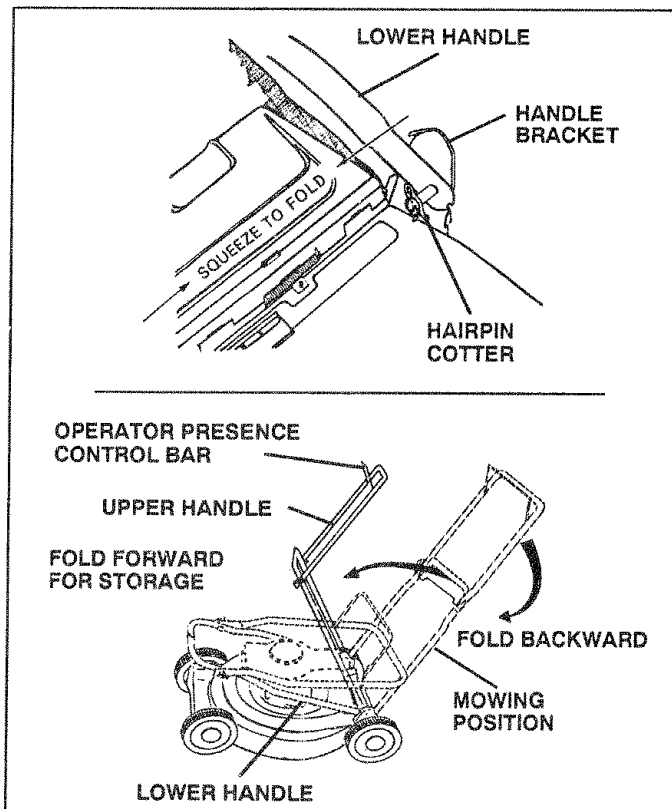

FIG. 21

ENGINE FUEL SYSTEM

IMPORTANT: IT IS IMPORTANT TO PREVENT GUM DEPOSITS FROM FORMING IN ESSENTIAL FUEL SYSTEM PARTS SUCH AS CARBURETOR, FUEL FILTER, FUEL HOSE, OR TANK DURING STORAGE. ALSO, EXPERIENCE INDICATES THAT ALCOHOL BLENDED FUELS (CALLED GASOHOL OR USING ETHANOL OR METHANOL) CAN ATTRACT MOISTURE WHICH LEADS TO SEPARATION AND FORMATION OF ACIDS DURING STORAGE. ACIDIC GAS CAN DAMAGE THE FUEL SYSTEM OF AN ENGINE WHILE IN STORAGE.

- Drain the fuel tank.
- Start the engine and let it run until the fuel lines and carburetor are empty.
- Never use engine or carburetor cleaner products in the fuel tank or permanent damage may occur.
- Use fresh fuel next season.

NOTE: Fuel stabilizer is an acceptable alternative in minimizing the formation of fuel gum deposits during storage. Add stabilizer to gasoline in fuel tank or storage container. Always follow the mix ratio found on stabilizer container. Run engine at least 10 minutes after adding stabilizer to allow the stabilizer to reach the carburetor. Do not drain the gas tank and carburetor if using fuel stabilizer.

ENGINE OIL

Drain oil (with engine warm) and replace with clean engine oil. (See "ENGINE" in the Customer Responsibilities section of this manual).

CYLINDER

- Remove spark plug.
- Pour one ounce (29 ml) of oil through spark plug hole into cylinder.
- Pull starter handle slowly a few times to distribute oil.
- Replace with new spark plug.

OTHER

- Do not store gasoline from one season to another.
- Replace your gasoline can if your can starts to rust. Rust and/or dirt in your gasoline will cause problems.
- If possible, store your unit indoors and cover it to give protection from dust and dirt.
- Cover your unit with a suitable protective cover that does not retain moisture. Do not use plastic. Plastic cannot breathe which allows condensation to form and will cause your unit to rust.

IMPORTANT: NEVER COVER MOWER WHILE ENGINE AND EXHAUST ARE STILL WARM.



CAUTION: Never store the lawn mower with gasoline in the tank inside a building where fumes may reach an open flame or spark. Allow the engine to cool before storing in any enclosure.

CRAFTSMAN 22" ROTARY LAWN MOWER MODEL NUMBER 917.372480

REPAIR PARTS

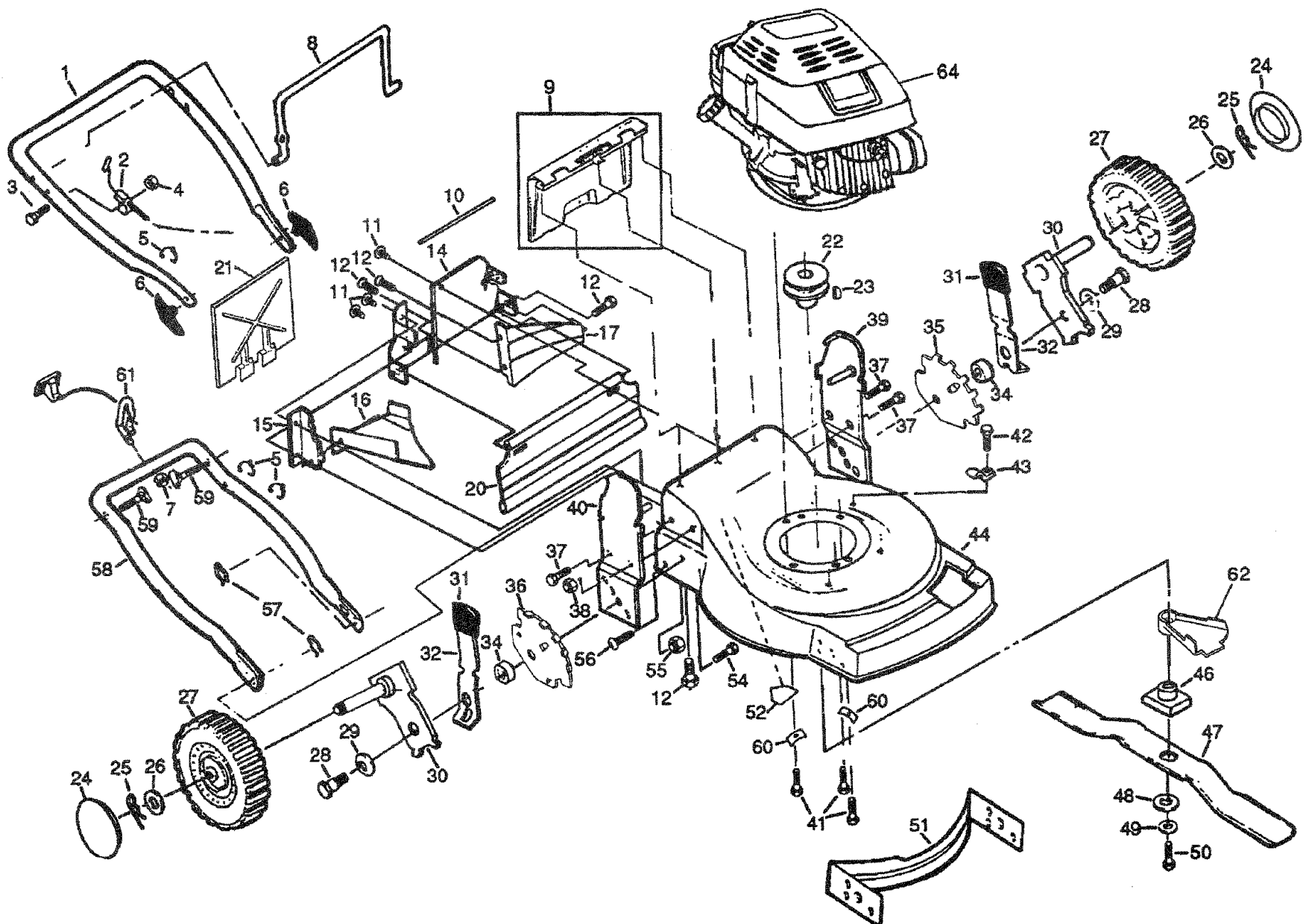

18

CRAFTSMAN 22" ROTARY LAWN MOWER MODEL NUMBER 917.372480

REPAIR PARTS

KEY PART NO. NO	DESCRIPTION
1 133088X479	Upper Handle
2 130861	Engine Zone Control Cable
3 STD522515	Hex Head Bolt 1/4-20 x 1-1/2
4 STD541425	Locknut 1/4-20
5 85827	Cable Clip
6 63688	Handle Knob
7 STD541425	Locknut 1/4-20
8 851509	Control Bar
9 48137	Rear Door Kit (Incl. Key #10)
10 750328	Hinge Rod
11 36953	Self Tapping Screw #10-24
12 STD512505	Hex Tapping Screw 1/4-20 x 1/2
14 88644X479	Back Plate
15 133189	Side Baffle
16 133190X417	Discharge Baffle
17 87596X479	Rear Baffle
20 128796	Rear Skirt
21 133170X479	Mulcher Plate
22 85543	Engine Pulley
23 87677	Hi-Pro Key #505
24 77400	Hubcap
25 85179	Retainer Clip
26 52160	Washer
27 87748	Wheel & Tire Assembly
28 84921	Shoulder Bolt 3/8-16
29 62335	Belleville Washer
30 85021X004	Axle Arm Assembly
31 87877	Selector Knob
32 850855X004	Selector Spring
34 84920	Spacer
35 850923	Wheel Adjusting Bracket (Left)
36 850924	Wheel Adjusting Bracket (Right)

KEY PART NO. NO	DESCRIPTION
37 55187	Thread Cutting Screw 5/16-18 x 3/4
38 STD541431	Locknut 5/16-18
39 86912X417	Handle Bracket Assembly (Left)
40 86913X417	Handle Bracket Assembly (Right)
41 850998	Hex Head Thread Rolling Screw 3/8-16 x 1-1/8
42 750097	Hex Washer Head Screw #10-24 x 1/2
43 87930	Guide Clip
44 48273	Lawn Mower Housing (Incl. Key #14,15,51 &52)
46 851514	Blade Adapter
47 752234	Blade 22"
48 851074	Hardened Washer
49 850263	Helical Washer 3/8-24 x 1-3/8 Grd. 8
50 851084	Hex Head Machine Screw 3/8-24 x 1-3/8 Grd. 8
51 87587X479	Front Baffle
52 85463	Danger Decal
54 STD533107	Carriage Bolt 5/16-18 x 5/8
55 751592	Locknut 3/8-16
56 88652	Hinge Screw
57 51793	Hairpin Cotter
58 84676X479	Lower Handle
59 131959	Handle Bolt
60 851201X004	Washer
61 103672X	Rope Guide
62 134612	Debris Shield
64 132961	Engine - Craftsman - Model No. 143.424152
-- 134078	Owner's Manual

Available accessories not included with lawn mower:

<u>71</u> 33303	Clipping Deflector
<u>71</u> 33623	Gas Can (2.5 gal.)
<u>71</u> 33500	Fuel Stabilizer
<u>71</u> 33300	SAE 30W Oil (20 oz.)
<u>71</u> 33417	Dust Shield
<u>71</u> 33316	Mower Cover

20

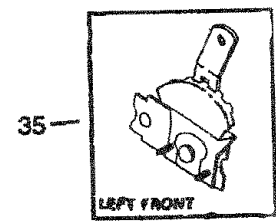
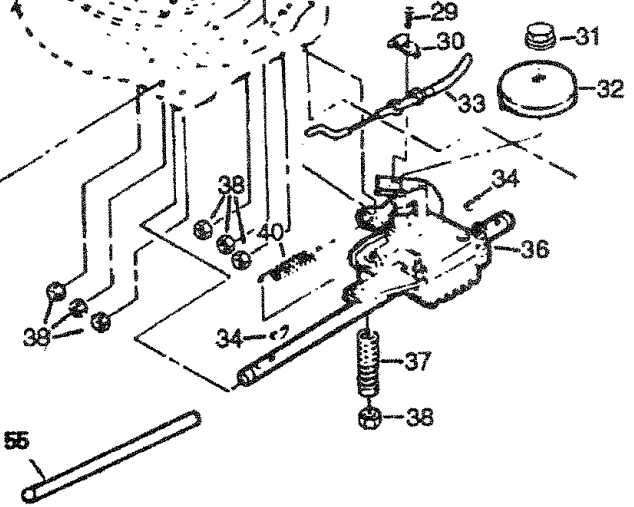
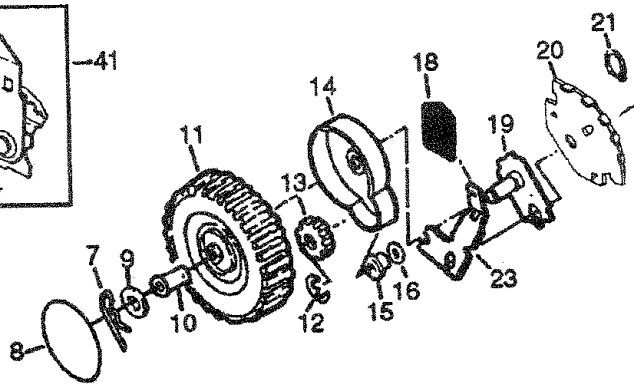
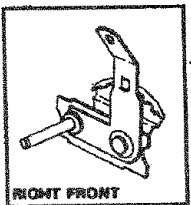
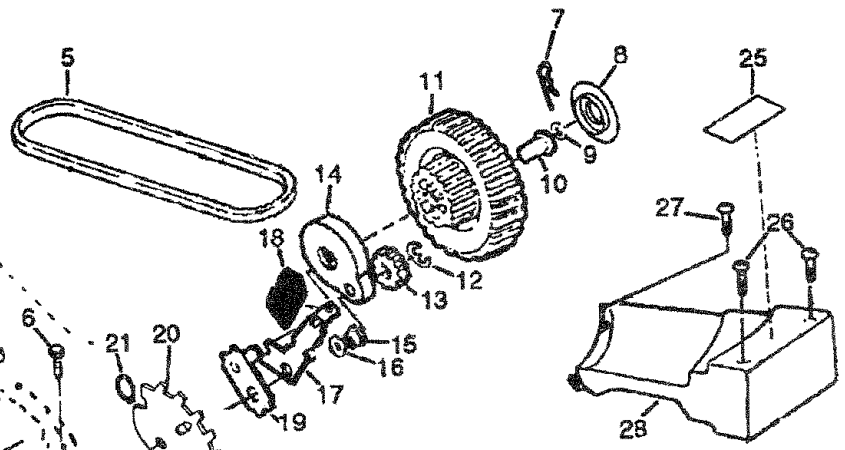
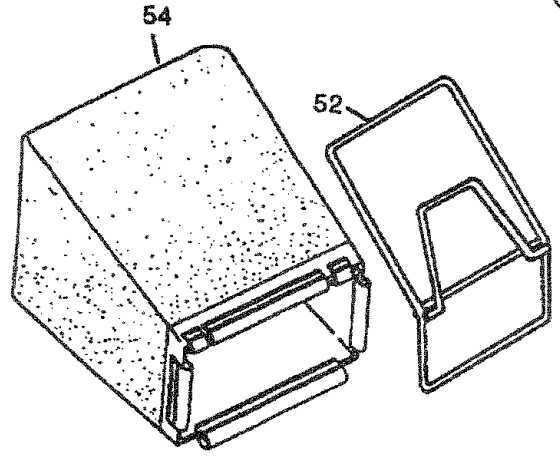
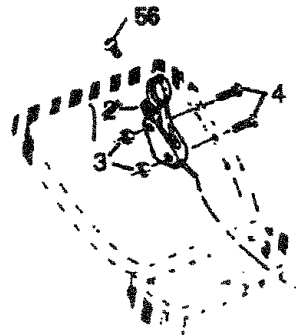
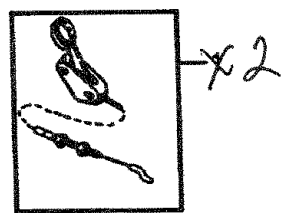

CRAFTSMAN 22" ROTARY LAWN MOWER MODEL NUMBER 917.372480

REPAIR PARTS

KEY PART NO.	PART NO.	DESCRIPTION
1	48029	Drive Head Kit
2	133049	Drive Control Kit
3	74189	Locknut #10-24
4	750029	Pan Head Machine Screw #10-24 x 2
5	83691	V-Belt
6	74760444	Hex Head Bolt 1/4-20 x 2-3/4
7	85179	Retainer Clip
8	77400	Hubcap
9	52160	Washer
10	86960	Nylon Bushing
11	87729	Wheel & Tire Assembly 8.00 x 2.00
12	12000003	E-Ring
13	74507	Pinion
14	76401	Dust Cover
15	86273	Spacer Bearing
16	86274	Belleville Washer
17	851019X004	Selector Spring (Left)
18	87877	Selector Knob
19	88284X004	Axle Arm Assembly
20	850922	Wheel Adjusting Bracket
21	58922	Retaining Clip
23	851021X004	Selector Spring (Right)

KEY PART NO.	PART NO.	DESCRIPTION
25	751031	Drive Cover Decal
26	87866	Pan Head Tapping Screw #10-24 x 2-3/4
27	750097	Hex Washer Head Screw #10-24 x 3/4
28	751029	Drive Cover <i>700989</i>
29	750108	Hex Washer Head Tapping Screw #10-24 x 3/8
30	83700	Cable Clamp
31	132010	Hex Flange Nut
32	431482	Drive Pulley
33	48269	Drive Control Cable Kit
34	STD580014	Woodruff Key #3
35	48175	Wheel Adjuster Assembly (Left)
36	48281	Gear Case Assembly
37	83632	Spring
38	STD541425	Locknut 1/4-20
40	75192	Spring
41	48174	Wheel Adjuster Assembly (Right)
52	88614	Catcher Frame
54	751663	Grassbag Assembly
55	86012	Driveshaft Cover
56	851552	Screw, Pan Head, Hi-Lo #10-16 x 1/2



GEAR CASE ASSEMBLY PART NUMBER 132232

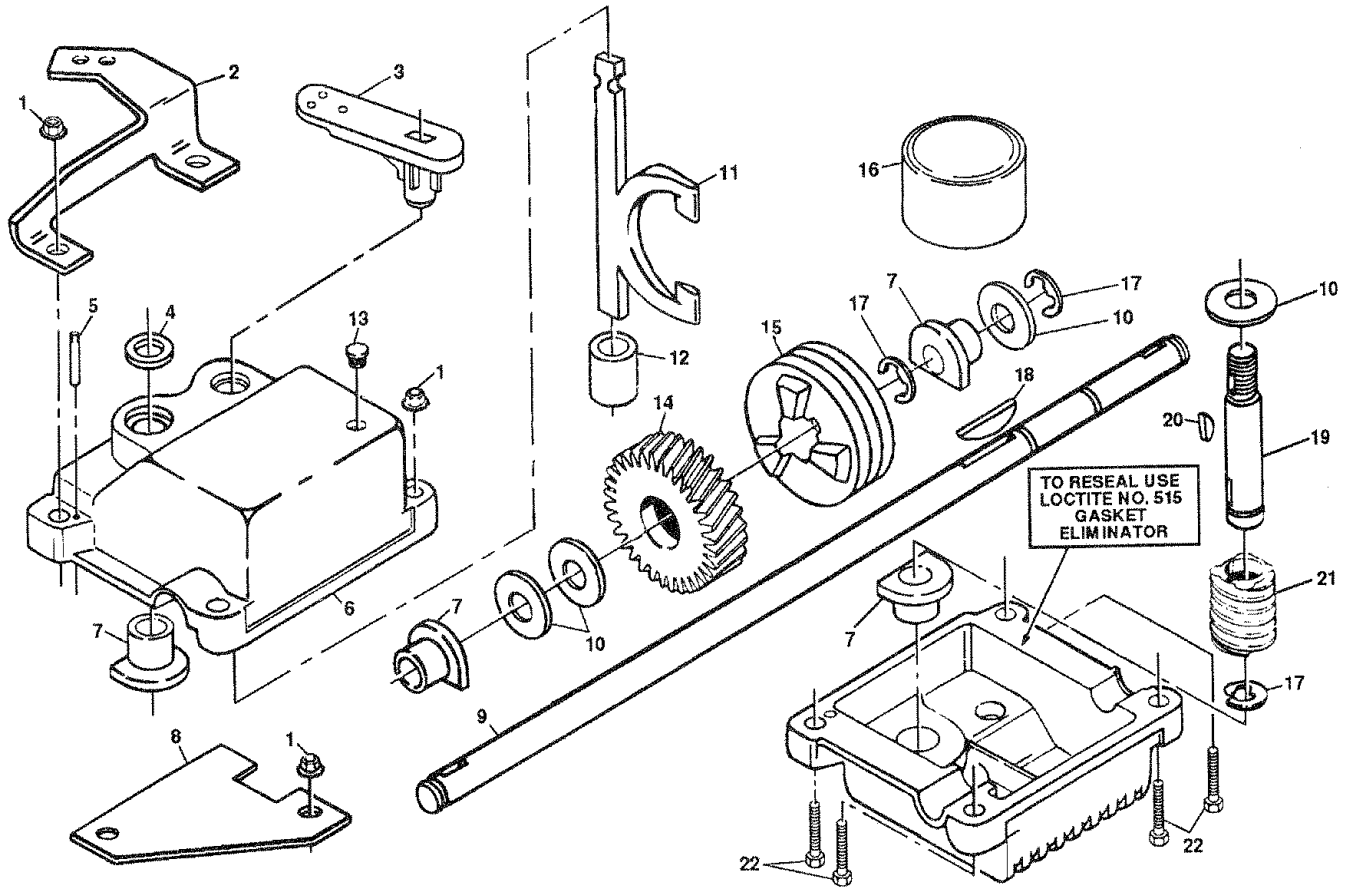

KEY PART
NO. NO.

DESCRIPTION

1	53838	Locknut, Keps 1/4-20
2	85178	Bracket, Adjusting
3	131483	Shifter
4	57072	Seal
5	57388	Pin, Grooved 1/8 x 1/2
6	48032	Gear Case Halves, Upper and Lower (Includes Key #4, 5 and 7)
7	77881	Bearing
8	77039	Bracket, Spring
9	750430	Drive Shaft
10	57079	Washer, Hardened
11	131484	Yoke, Clutch
12	131485	Bushing

KEY PART
NO. NO.

DESCRIPTION

13	86447	Plug
14	133804	Gear, Helical
15	750436	Jaw, Clutch
16	750355	Grease
17	STD581050	E-Ring
18	850848	Key, Hi-Pro
19	131481	Shaft, Worm
20	65692	Key, Woodruff, #3
21	83680	Worm
22	STD522512	Screw, Hex Head 1/4-20 x 1-1/4

NOTE: All component dimensions given in U.S. inches
1 inch = 25.4 mm

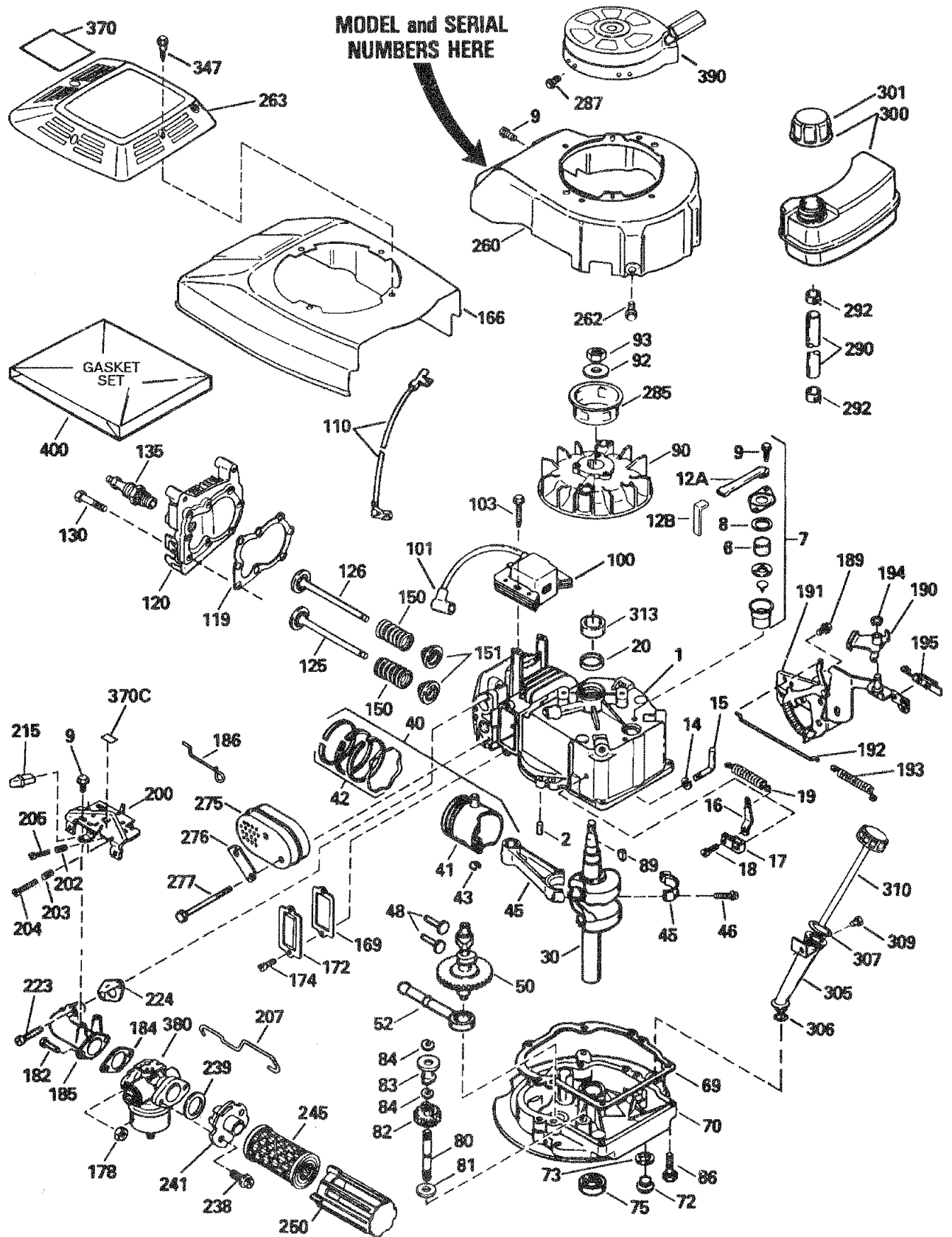

CRAFTSMAN 4-CYCLE ENGINE

MODEL NO. 143.424152

REF NO.	PART NO.	DESCRIPTION	REF NO.	PART NO.	DESCRIPTION
1	33968B	Cylinder Assembly (Includes #2, 20)	150	31672	Spring, Valve
2	26727	Pin, Dowel	151	31673	Cap, Lower Valve Spring
6	33734	Element, Breather	166	35827	Shroud, Engine
7	34214A	Breather Assembly (Includes Reference #6, 8, 9, 12A and 12B)	169	27234A	* Gasket, Valve Spring Box
8	33735	* Gasket, Breather	172	32755	Cover, Valve Spring Box
9	30200	Screw, Sems, Hex Washer Head, Self-Tapping #10-24 x 9/16	174	650128	Screw, Sems, Hex Hd. #10-24 x 1/2
12A	33886	Tube, Breather	178	29752	Nut and Lock Washer 1/4-28
12B	34695	Elbow, Breather Tube	182	6201	Screw, Hex Hd., Cap 1/4-28 x 7/8
14	28277	Washer, Flat	184	26756	* Gasket, Carburetor
15	30589	Rod, Governor (Includes Ref. #14)	185	31384A	Pipe, Intake (Includes Ref. #224)
16	31383A	Lever, Governor	186	34358	Link, Governor Spring
17	31335	Clamp, Governor Lever	189	650839	Screw, Sems, Hex Head, Powerlok 1/4-20 x 3/8
18	650548	Screw, Hex Washer #8-32 x 5/16	190	35831	Lever, Brake
19	31361	Spring, Extension	191	35039B	Bracket, S.E. Brake (Includes #195)
20	32600	Seal, Oil	192	34966	Link, Control
30	35801	Crankshaft Assembly	193	34965	Spring, Extension
40	34535	Piston, Pin & Ring Assembly, Std.	194	32309	Ring, Retaining
	34536	Piston, Pin & Ring Assy. .010" over	195	610973	Terminal Assembly
	34537	Piston, Pin & Ring Assy. .020" over (Assemblies Include #41, 42 and 43)	200	35727	Bracket Assembly, Control (Includes Reference #202 thru 205)
41	33562B	Piston & Pin Assembly, Standard	202	33802	Spring, Compression
	33563B	Piston & Pin Assembly .010" over	203	31342	Spring, Compression
	33564B	Piston & Pin Assembly .020" over (Assemblies Include Reference #43)	204	650549	Screw, Fillister Head #5-40 x 7/16
42	33567	Ring Set, Piston, Standard Size	205	650777	Screw, Fillister Head #6-32 x 21/32
	33568	Ring Set, Piston .010" oversize	207	34336	Link, Throttle
	33569	Ring Set, Piston .020" oversize	215	35511	Knob, Control
43	20381	Ring, Piston Pin Retaining	223	650451	Screw, Sems, Hex Head 1/4-20 x 1
45	32875	Rod Assy., Connecting (Incl. #46)	224	34690A	* Gasket, Intake Pipe
46	32610A	Bolt, Connecting Rod	238	650932	Screw, Hex Washer Head, Shoulder #10-32 x 49/64
48	27241	Valve, Lifter	239	34338	* Gasket, Air Cleaner
50	33553	Camshaft, Mech. Comp. Release	241	35797	Collar, Air Cleaner
52	29914	Pump Assembly, Oil	245	35066	Filter, Air Cleaner, Paper
69	35261	* Gasket, Mounting Flange	250	35065	Cover, Air Cleaner
70	34311C	Flange, Mount. (Incl. #72,73,75,80)	260	35826	Housing, Blower
72	30572	Plug, Oil Drain (Includes Ref. #73)	262	650831	Screw, Hex Washer Head, Powerlok Thread 1/4-20 x 15/32
73	28833	Gasket, Oil Drain Plug (Not Required with Plastic Oil Plug)	263	35821	Grill Assembly, Recoil
75	27897	Seal, Oil	275	34613	Muffler Assembly (Includes #277)
80	30574	Shaft, Governor	276	33753	Plate, Lock
81	30590A	Washer, Flat	277	650795	Screw, Hex Head 1/4-20 x 2-1/4
82	30591	Gear Assy., Governor (Incl. #81)	285	35000	Hub, Starter
83	30588A	Spool, Governor	287	650884	Screw, Hex Wash. Hd. #8-32 x 1/2
84	29193	Ring, Retaining	290	34357	Line, Fuel
86	650488	Screw, Sems, Hex 1/4-20 x 1-1/4	292	26460	Clamp, Fuel Line
89	611004	Key, Flywheel	300	35586	Tank Assy. (Includes #292 & 301)
90	611109	Flywheel	301	35355	Cap, Fuel
92	650815	Washer, Belleville	305	35819A	Tube, Oil Fill (Includes Ref. #309)
93	650816	Nut, Flywheel	306	34265	* Gasket, Fill Tube
100	34443A	Solid State Assembly	307	35499	"O" Ring
101	610118	Cover, Spark Plug	309	650936	Screw, Hex Washer Head, Shoulder #10-32 x 13/32
103	650814	Screw, Torx T-15, Hex Washer Head #10-24 x 1	310	35822	Dipstick, Oil Fill
110	34961	Wire, Ground	313	34080	Spacer, Flywheel Key
119	33554A	* Gasket, Cylinder Head	347	650898	Screw, Hex Washer Head, Shoulder #10-32 x 27/32
120	34342	Head, Cylinder	370	35840	Decal, Name
125	29313C	Valve, Exhaust, Standard Size	370C	35167	Decal, Instruction
	29315C	Valve, Exhaust, 1/32" oversize	380	632078A	Carburetor (Includes Ref. #184)
126	29314B	Valve, Intake, Standard Size	390	590637	Starter, Rewind
	29315C	Valve, Intake, 1/32" oversize (All Valves Include Reference #151)	400	35997	Gasket Set (Incl. items marked *)
130	6021A	Screw, Hex Flange 5/16-18 x 1-1/2			RPM Setting: Low Speed: 2450-2750, High: 2900-3200
135	35395	Spark Plug, Resistor Type (Champion RJ-19LM or Equivalent)			*Indicates Parts Included in Gasket Set, Reference #400

NOTE: All component dimensions given in U.S. inches
1 inch = 25.4 mm

CRAFTSMAN 4-CYCLE ENGINE

MODEL NO. 143.424152

CARBURETOR NO. 632078A

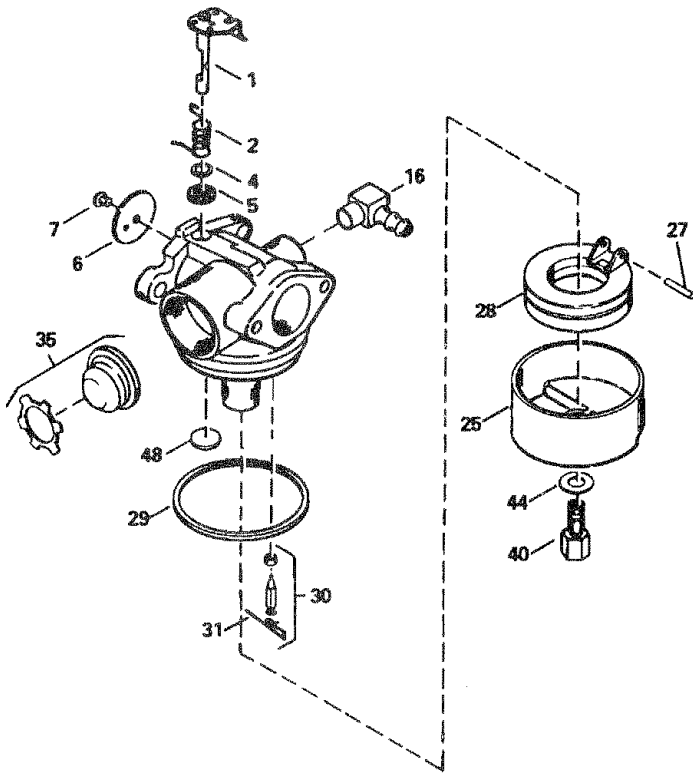

REF PART NO.	PART NO.	DESCRIPTION
1	631615	Throttle Shaft and Lever Assembly
2	631767	Throttle Return Spring
4	631184	Dust Seal Washer
5	631971	Dust Seal
6	631616	Throttle Shutter
7	650506	Throttle Shutter Screw
16	632527	Fuel Fitting
25	631700	Float Bowl
27	631024	Float Shaft
28	632019	Float
29	631028	"O" Ring, Float Bowl to Body
30	631021	Inlet Needle, Seat & Clip (Incl. #31)
31	631022	Spring Clip
35	632047	Primer Bulb/Retainer Ring
40	632071	High Speed Bowl Nut
44	631334	Bowl Nut Washer
48	631027	Welch Plug, Atmospheric Vent

NOTE: All component dimensions given in U.S. inches
1 inch = 25.4 mm

REWIND STARTER NO. 590637

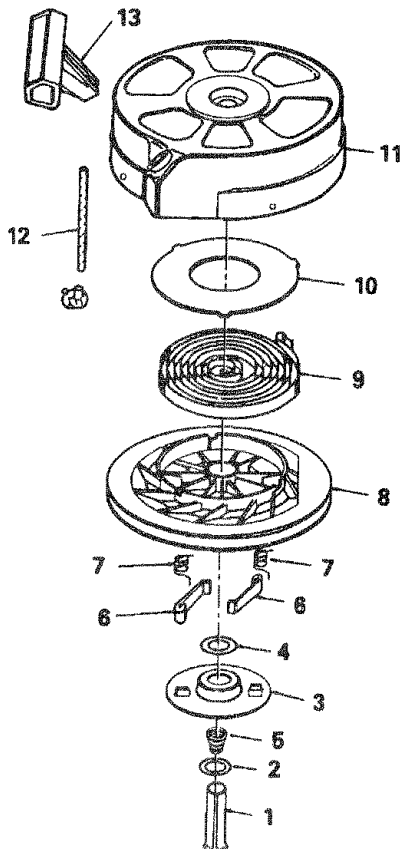

REF PART NO.	PART NO.	DESCRIPTION
--	590637	Starter, Rewind
1	590599	Pin, Spring (Includes Reference #4)
2	590600	Washer
3	590615	Retainer
4	590601	Washer
5	590598	Spring, Brake
6	590616	Dog, Starter
7	590617	Spring, Dog
8	590618	Pulley
9	590619	Spring, Rewind
10	590620	Cover, Spring
11	590638	Housing Assembly, Starter
12	590535	Rope, Starter (98" long, 9/64" dia.)
13	590452	Handle, Starter

NOTE: All component dimensions given in U.S. inches
1 inch = 25.4 mm

SERVICE NOTES



TROUBLESHOOTING POINTS

PROBLEM	CAUSE	CORRECTION
Does not start	<ol style="list-style-type: none"> 1. Dirty air filter. 2. Out of fuel. 3. Stale fuel. 4. Water in fuel. 5. Spark plug wire is disconnected. 6. Bad spark plug. 7. Loose blade or broken blade adapter. 8. Control bar in released position 9. Control bar defective 	<ol style="list-style-type: none"> 1. Clean/replace air filter. 2. Fill fuel tank. 3. Drain tank and refill with fresh clean fuel. 4. Drain fuel tank and carburetor and refill tank with fresh gasoline. 5. Connect wire to plug. 6. Replace spark plug. 7. Tighten blade bolt or replace blade adapter. 8. Depress control bar to handle. 9. Replace control bar.
Loss of power	<ol style="list-style-type: none"> 1. Rear of lawn mower housing/blade dragging in heavy grass. 2. Cutting too much grass. 3. Dirty air filter. 4. Buildup of grass, leaves and trash under mower. 5. Too much oil in engine. 6. Walking speed too fast. 	<ol style="list-style-type: none"> 1. Set in "Higher Cut" position. 2. Set in "Higher Cut" position. 3. Clean/replace air filter. 4. Clean underside of mower housing. 5. Check oil level. 6. Cut at slower walking speed.
Poor cut - uneven	<ol style="list-style-type: none"> 1. Worn, bent or loose blade. 2. Wheel heights uneven. 3. Low engine speed. 4. Buildup of grass, leaves, and trash under mower. 	<ol style="list-style-type: none"> 1. Replace blade. Tighten blade bolt. 2. Set all wheels at same height. 3. Set engine speed control in HIGH position. 4. Clean underside of mower housing.
Excessive vibration	<ol style="list-style-type: none"> 1. Worn, bent or loose blade. 2. Bent engine crankshaft. 	<ol style="list-style-type: none"> 1. Replace blade. Tighten blade bolt. 2. Contact Sears Service Department.
Starter rope hard to pull	<ol style="list-style-type: none"> 1. Engine flywheel brake is on when control bar is released. 2. Bent engine crankshaft 3. Blade adapter broken. 4. Blade dragging in grass. 	<ol style="list-style-type: none"> 1. Depress control bar to upper handle before pulling starter rope. 2. Contact Sears Service Department. 3. Replace blade adapter. 4. Move lawn mower to cut grass or to hard surface to start engine.
Loss of drive	<ol style="list-style-type: none"> 1. Drive wheels not turning with drive control engaged. 2. Belt not driving. 	<ol style="list-style-type: none"> 1. Adjust or replace drive control cable, if broken. 2. Put belt on pulleys or replace belts if broken.
Grass catcher not filling (If so equipped)	<ol style="list-style-type: none"> 1. Cutting height too low. 2. Lift on blade worn off. 3. Catcher not venting air. 4. Low engine speed. 	<ol style="list-style-type: none"> 1. Raise cutting height. 2. Replace blade. 3. Clean grass catcher. 4. Set engine speed control in HIGH position.
Hard to push	<ol style="list-style-type: none"> 1. Grass is too high or wheel height is too low. 2. Rear of lawn mower housing/blade dragging in grass. 3. Grass catcher too full. 4. Handle height position not right for you. 	<ol style="list-style-type: none"> 1. Raise cutting height. 2. Raise rear of lawn mower housing one (1) setting higher. 3. Empty grass catcher. 4. Adjust handle height to suit.

SEARS

**OWNER'S
MANUAL**

**MODEL NO.
917.372480**

**HOW TO ORDER
REPAIR PARTS**

CRAFTSMAN®

**5.0 HORSEPOWER
22" REAR DISCHARGE
2 in ONE Mulcher/Bagger
POWER PROPELLED
ROTARY LAWN MOWER**

Each Lawn Mower has its own model number. Each engine has its own model number.

The model number for your lawn mower will be found on a decal attached to the rear of the lawn mower housing.

The model number for the engine will be found on the Blower Housing of the engine adjacent to the spark plug.

All parts listed here in may be ordered through Sears, Roebuck and Co. Service Centers and most Retail Stores.

**WHEN ORDERING REPAIR PARTS, ALWAYS GIVE THE
FOLLOWING INFORMATION:**

- **PRODUCT - "ROTARY LAWN MOWER"**
- **MODEL NUMBER - 917.372480**
- **ENGINE - CRAFTSMAN - MODEL NO. 143.424152**
- **PART NUMBER**
- **PART DESCRIPTION**

Your Sears merchandise has added value when you consider that Sears has service units nationwide staffed with Sears trained technicians...professional technicians specifically trained on Sears products, having the parts, tools and the equipment to insure that we meet our pledge to you, we service what we sell.

134078 Rev. 2 02/27/92

Printed in U.S.A.

SEARS, ROEBUCK AND Co., Chicago, IL. 60684 U.S.A.