

ASSEMBLY INSTRUCTIONS

CAUTION

INSPECT CONTENTS IMMEDIATELY AND FILE CLAIM WITH DELIVERING CARRIER FOR ANY DAMAGE. **SAVE YOUR BOX AND ALL PACKING MATERIALS.** YOU ARE RESPONSIBLE FOR DAMAGE TO YOUR UNIT IF RETURNED IMPROPERLY PACKED.

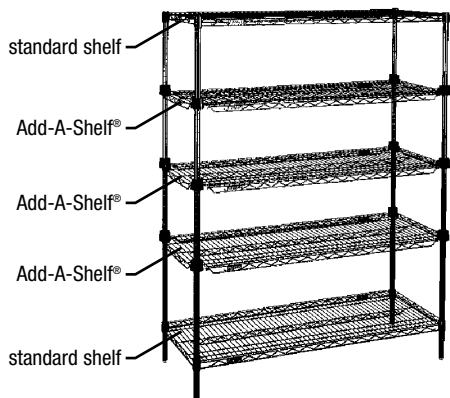

Add-A-Shelf® shown assembled to shelf unit.

Parts List

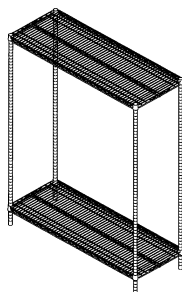
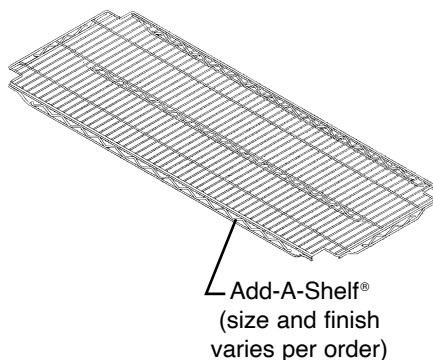

Step 1 - Install top and bottom standard shelves on four posts.
See shelving installation instructions.

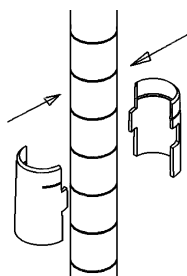

Step 2 - Plastic Split Sleeves
Snap the split sleeves (#A200816) onto a post over the number of your choice.

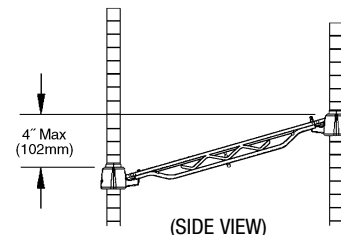

Note: You may slant your shelf by offsetting the split collars to a maximum of 4".

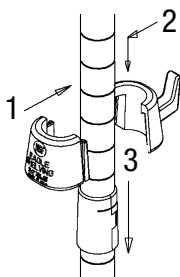

Step 3 - Plastic Split Collars

- 1: Hold one half of the split collar (#A208891) around the post.
- 2: Bring the second around the post, above the first half, and slide the two together.
- 3: Once together, slide the collar assembly over the split sleeve, applying pressure over the shelf support finger.

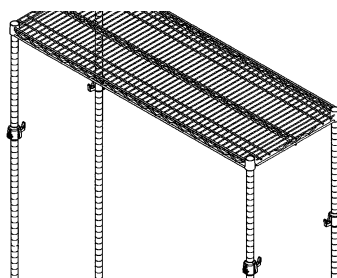

Step 4 - Repeat Step 3 on remaining posts.

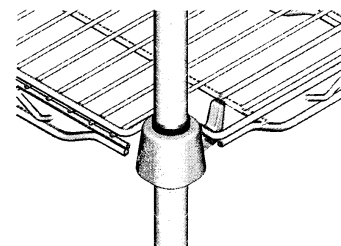

Step 5 - Shelf

Place Add-A-Shelf® over split collar support fingers.

(End)

Additional Notes:

- Use Add-A-Shelf® for intermediate shelves. Top and bottom shelves of a shelf unit must be standard shelves.
- Maximum weight capacity of Add-A-Shelf® is 300 lbs. static load per shelf.
- Add-A-Shelf® is not recommended for use in mobile applications.