

Use & Care Guide



Liquid Propane Gas Grill

Sears Model No: 119.16216010

Kmart Item No: 640-01331376-2

- Safety
- Parts
- Use and Care
- Assembly
- Español, Pg. 27

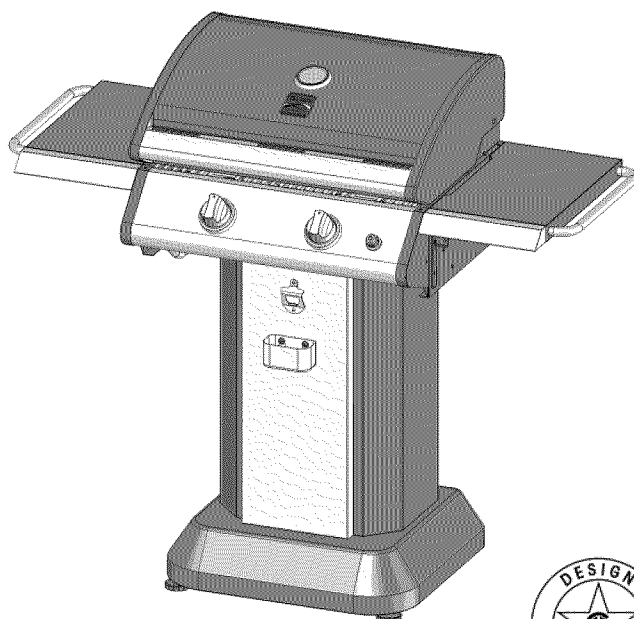

This Grill is for Outdoor Use Only



- Read and follow all Safety, Assembly, and Use & Care Instructions in this Guide before assembling and cooking with this grill.
- Failure to follow all instructions in this Use & Care Guide may lead to fire or explosion, which could result in property damage, personal injury or death.

Grill Information Center

Missing Parts? Assembly Questions? Operation Problems? Before returning grill to store, call **1-800-933-0527**

Tools needed for assembly:

Protective work gloves and eyewear
Phillips head screwdriver (included in hardware pack)

SAVE THESE INSTRUCTIONS!

See our extensive assortment of outdoor living products on-line at www.sears.com and www.kmart.com

Sears Brands Management Corporation, Hoffman Estates, IL 60179 U.S.A.

Table of Contents

Primary Safety Warnings.....	1-3
Warranty Information.....	2
Pre-Assembly Instructions.....	3
Part Diagram and Lists.....	4-6
Assembly Instructions.....	8-17
Use & Care Instructions.....	18-27
Frequently Asked Questions.....	27
Spanish Guide.....	28-54
Repair Protection Agreement.....	55
Sears Parts and Service Information	56

Warranty

Kenmore Full Warranty

If this grill fails due to a defect in material or workmanship within one year from the date of purchase, call 1-800-4-MY-HOME® to arrange for free repair (or replacement if repair proves impossible). For five years from the date of purchase, the stainless steel burners will be replaced free of charge if they rust through. After the first year from the date of purchase, you must pay the labor cost to have them installed.

All warranty coverage excludes ignitor batteries, grill part paint loss, discoloration, and surface rusting, which are either expendable parts that can wear out from normal use within the warranty period, or are conditions that can be the result of normal use, accident or improper maintenance.

All warranty coverage is void if this grill is ever used for commercial or rental purposes.

All warranty coverage applies only if this grill is used in the United States.

This warranty gives you specific legal rights, and you may have other rights which vary from state to state.

Sears, Roebuck and Co., Hoffman Estates, IL 60179

CAUTION

For residential use only. Do not use for commercial cooking.



DANGER



IF YOU SMELL GAS:

- **Shut off gas to the appliance.**
- **Extinguish any open flame.**
- **Open lid.**
- **If odor continues, keep away from the appliance and immediately call your gas supplier or your fire department.**



WARNING



- **Do not store or use gasoline or other flammable liquids or vapors in the vicinity of this or any other appliance.**
- **An LP cylinder not connected for use shall not be stored in the vicinity of this or any other appliance.**

Grill Information Center

If you are missing parts, need assistance during assembly, or have any other questions, please call 1-800-933-0527 between the hours of 8:30am and 5:00pm, Monday through Friday, Central time. Note that you will be speaking with a representative of the grill manufacturer and not a Sears employee.

Product Record

IMPORTANT: Fill out the product record information on below.

- **Model Number** 119.16216010
- **Serial Number** _____
(See silver CSA plate inside of Cabinet Panel)
- **Date Purchased** _____



WARNING



California Proposition 65

1. Combustion by-products produced when using this product contain chemicals known to the State of California to cause cancer, birth defects, and other reproductive harm.
2. This product contains chemicals, including lead and lead compounds, known to the State of California to cause cancer, birth defects or other reproductive harm.

Safety Information



WARNING



- DO NOT light this grill without first reading the Lighting Instructions.
- DO NOT light this grill without checking the burner tubes for blockage that could have occurred during shipment. See the Cleaning and Maintenance Instructions.



WARNING



- DO NOT use any type of charcoal in this grill.
- DO NOT operate the main burners and back burner at the same time. (If Equipped)
- ALWAYS inspect the grease tray before each use. Remove and clean as necessary.



WARNING



This outdoor cooking gas appliance is not intended to be installed in or on boats or recreational vehicles.



WARNING



Liquid Propane Gas (LPG) grills must be used with the liquid propane gas regulator assembly supplied. This grill is not convertible to natural gas.

ALWAYS keep the gas hose assembly away from any heated surface and dripping grease. Avoid unnecessary twisting of the hose. Visually inspect the hose prior to each use for cuts, cracks, excessive wear, or other damage. Do not use the gas grill if the hose appears damaged. Call Sears at 1-800-4-MY-HOME® (1-800-469-4663) for a Kenmore replacement gas hose assembly.

Grill Installation Codes

The installation must conform with local codes or, in the absence of local codes, with either the National Fuel Gas Code, ANSI Z223.1/NFPA 54, or CAN/CGA B149.1, Natural Gas and Propane Installation Code, or Propane Storage and Handling Code, B149.2.

Electrical Grounding

All electrical accessories (such as a rotisserie or light) must be electrically grounded in accordance with local codes, or in the absence of local codes, with the National Electrical Code, ANSI/NFPA 70, or the Canadian Electrical Code, CSA C22.1. Keep any electrical cords away from hot surfaces.

General Safety

- NEVER use your gas grill in a building, garage, porch, shed, breezeway or any other enclosed area.
- NEVER obstruct the flow of ventilation air around your gas grill cabinet.
- DO NOT leave children and pets unattended in the area when the grill is in operation.
- ENSURE the grill is on a level surface when in operation. You can adjust the feet in front to level and stabilize the grill.
- NEVER attach an unregulated gas line to this appliance.

PRE-ASSEMBLY

- Two people will be necessary to assemble the larger parts of the grill.
- Lay a cardboard sheet on the floor and use as a work surface to protect floor and grill parts from scratches.
- Once all parts are removed and unpacked, use the Hardware and Part Diagrams to ensure all items are included and free of damage.

Hardware Pack Diagram

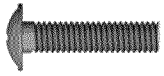

A

Phillips Head Bolt M6x25mm
Qty: 2 pcs

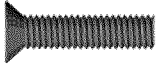

B

Flat Head Bolt M6x25mm
Qty: 4 pcs



C

Step Bolt M6
Qty: 4 pcs



D

Flat Heat Bolt M6x12mm
Qty: 8 pcs



E

Phillips Head Bolt M6x10mm
Qty: 7 pcs



F

Washer Head Bolt M4x10mm
Qty: 14 pcs

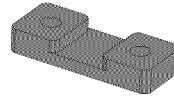

G

Grill Transport Handle Heat Shield
Qty: 2 pcs

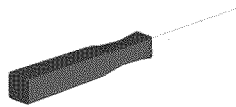

H

Phillips Head Screwdriver
Qty: 1 pc



I

Battery Size AAA
Qty: 1 pc



J

Propane Tank Support Chain Hook
Qty: 1 pc



K

Propane Tank Support Chain
Qty: 1 pc

Parts List 119.16216010

Key	Qty	Part No.	Description
A1	1		Hood Assembly
A2	2		Hood Bolt Assembly
A3	1		Thermometer
A4	1		Thermometer Seat
B1	1		Firebox Assembly
B2	1		Gas Manifold Assembly
B3	2		Side Shelf Right Front and Left Back Support
B4	2		Side Shelf Left Front and Right Back Support
B5	1		Control Panel Left Support
B6	1		Regulator and Hose Assembly
B7	1		Control Panel Right Support
B8	1		"U" Burner - Left
B9	1		"U" Burner - Right
B10	1		Firebox Front Heat Shield
B11	1		Control Panel
B12	1		Manual Igniter Stick
B13	2		Control Knob
B14	2		Control Knob Seat
B15	2		Grill Transport Handle Heat Shield
B16	1		Grill Transport Handle
B17	1		Warming Rack
B18	2		Cooking Grate
B19	2		Heat Diffuser
B20	1		Firebox Rear Heat Shield
B21	1		Grease Pan
B22	1		Grease Pan Bracket
B23	1		Heat Shield
B24	1		Firebox Assembly Support
B25	1		Electronic Igniter
B26	1		Electronic Igniter Button
B27	2		Electrode

Parts List 119.16216010

Key	Qty	Part No.	Description
B28	4		Hood Bumper
B29	2		Electronic Igniter Wire Set
C1	2		Cabinet Side Panel
C2	1		Cabinet Front Panel
C3	1		Cabinet Frame
C4	1		Cabinet Base
C5	2		Caster
C6	2		Adjustable Foot
C7	1		Bottle Opener
C8	1		Bottle Cap Catcher
C9	1		Propane Tank Support Chain Hook
C10	1		Propane Tank Support Chain
D1	1		Left Shelf Assembly
D2	1		Right Shelf Assembly
D3	2		Shelf Handle
D4	1		Side Shelf Left Front Panel
D5	1		Side Shelf Right Front Panel

Not Pictured

N/A	1		Hardware Pack
N/A	1		Manual

If you are missing hardware or have damaged parts after unpacking grill, call 1-800-933-0527 for replacement.

To order replacement parts after using grill, call 1-800-4-MY-HOME®.

Parts Diagram 119.16216010

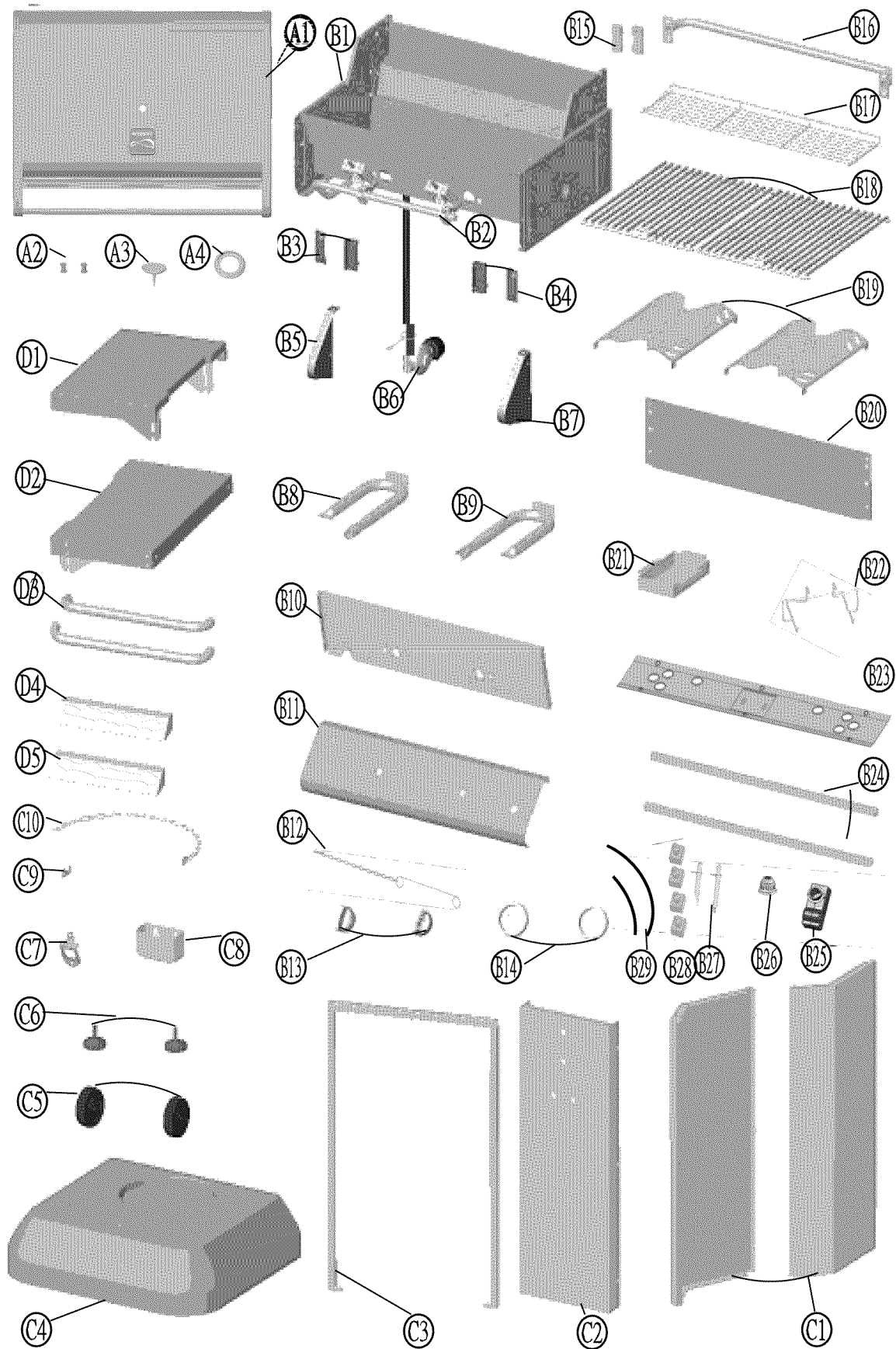

Assembly Instruction

1

Install Cabinet Left Side Panel and Right Side Panel

- Attach Cabinet Left Side Panel to the Cabinet Base using 1 Phillips Head Bolt (M6x10mm).
 - Attach Cabinet Right Side Panel to the Cabinet Base using 1 Phillips Head Bolt (M6x10mm).
- Do not fully tighten any bolts at this time.



Phillips Head Bolt M6x10mm
Qty: 2

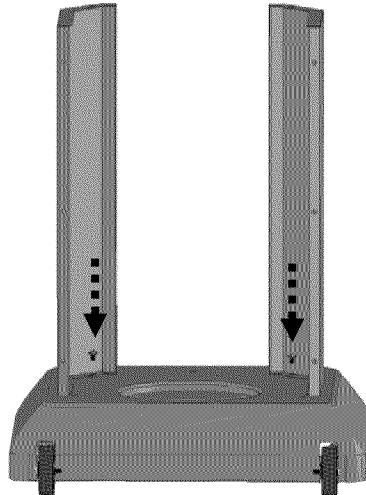

2

Install Cabinet Front Panel

- Attach Cabinet Front Panel to the Cabinet Base using 1 Phillips Head Bolt (M6x10mm).
- Attach Cabinet Front Panel to the Cabinet Left and Right Side Panels using 6 Washer Head Bolts (M4x10mm). Do not fully tighten any bolts at this time.



Phillips Head Bolt M6x10mm
Qty: 1

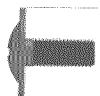

Washer Head Bolt M4x10mm
Qty: 6

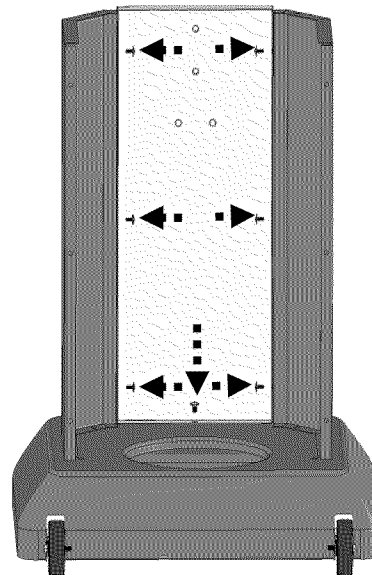

3

Install Cabinet Frame

- Slide Cabinet Frame into position between side panels as shown.
- Attach the Cabinet Frame to the Cabinet Base using 2 Phillips Head Bolts (M6x10mm).
- Attach the Cabinet Frame to the Cabinet Left and Right Side Panels using 5 Washer Head Bolts (M4x10mm). Now ensure base and cabinet components are square and tighten all bolts used in the cabinet assembly.



Phillips Head Bolt M6x10mm
Qty: 2



Washer Head Bolt M4x10mm
Qty: 5

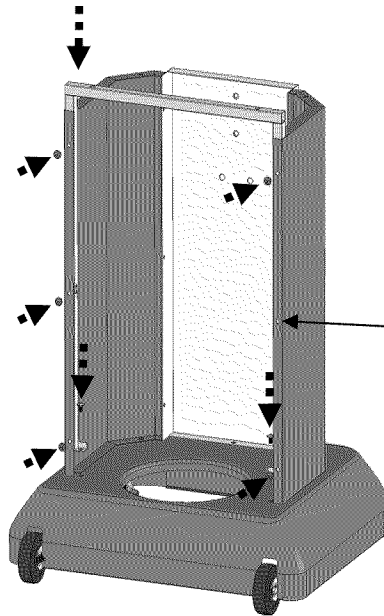

Note: Do not install this center bolt at this time.

4

Attach Propane Tank Support Chain and Propane Tank Support Chain Hook

- Attach the Propane Tank Support Chain to Cabinet Frame using 1 Washer Head Bolt (M4x10mm).
- Attach the Propane Tank Support Chain Hook to Cabinet Frame using 1 Washer Head Bolt (M4x10mm).



Propane Tank Support Chain Hook
Qty: 1



Washer Head Bolt M4x10mm
Qty: 2

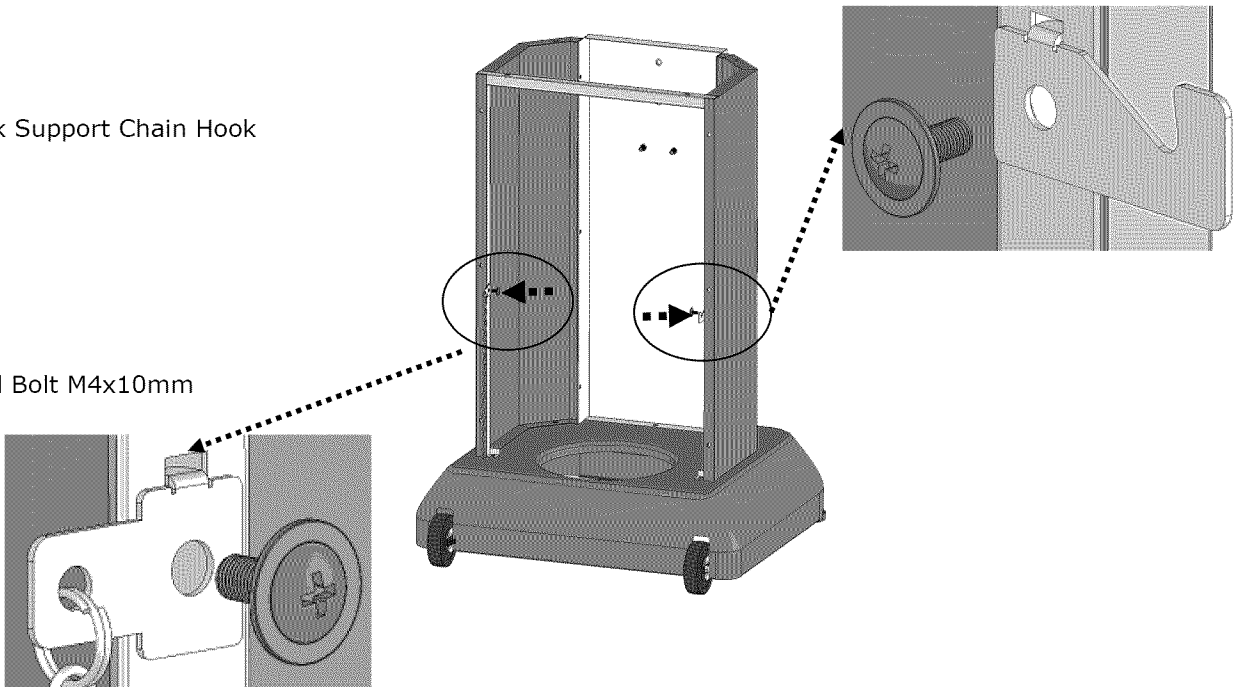

5**Hang Bottle Cap Catcher**

- Hang Bottle Cap Catcher on the Cabinet Front Panel.

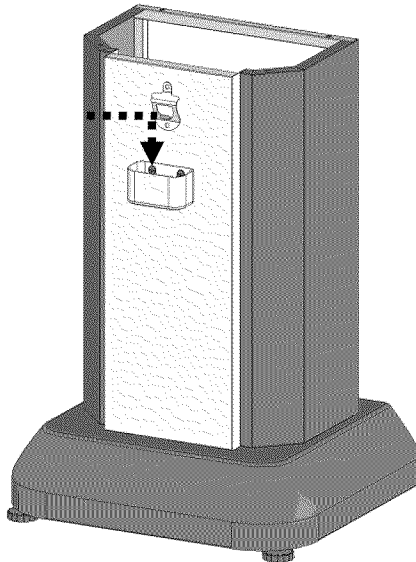
**6****Install Hood and Firebox Assembly**

- Remove regulator and hose from underside of Hood and Firebox Assembly. Remove packing from regulator.
- With the aid of an assistant, place Hood and Firebox Assembly onto the Cabinet, and attach to the Cabinet Frame using 2 Phillips Head Bolts (M6x25mm).

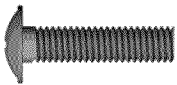

Phillips Head Bolt M6x25mm
Qty: 2

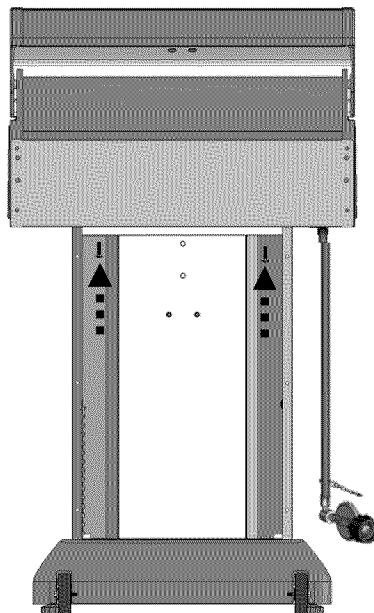

7

Attach Hood and Firebox Assembly to Cabinet Front

- Attach the Hood and Firebox Assembly to the front of the Cabinet Side Panels using 2 Phillips Head Bolts (M6x10mm).



Phillips Head Bolt M6x10mm
Qty: 2

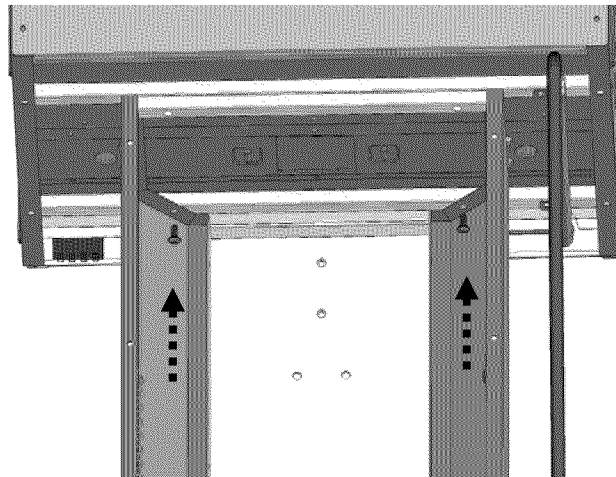

8

Install Grease Pan Bracket and Grease Pan

- Insert the Grease Pan Bracket into the bottom of Heat Shield.
- Insert the Grease Pan into the Grease Pan Bracket as shown.

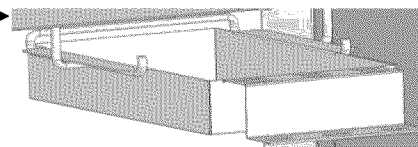
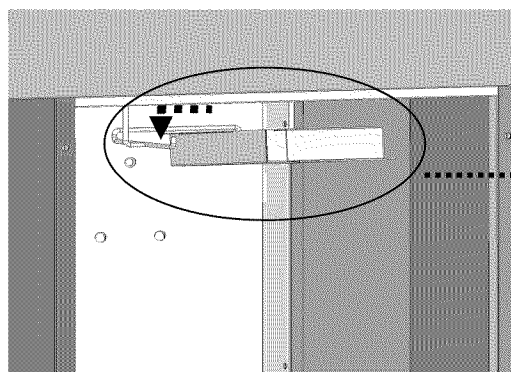
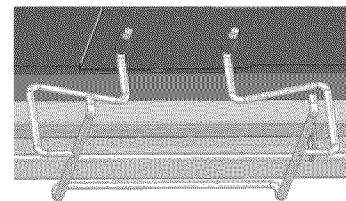
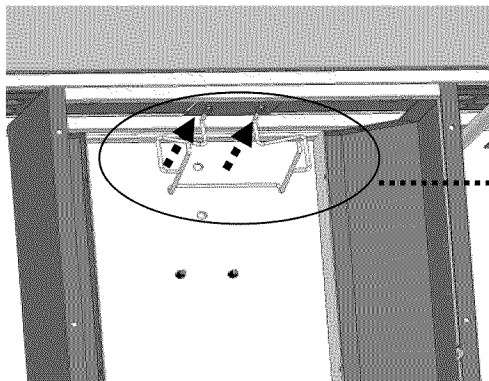

9

Install Control Knobs

- Press 2 Control Knobs onto the valve stems as shown.

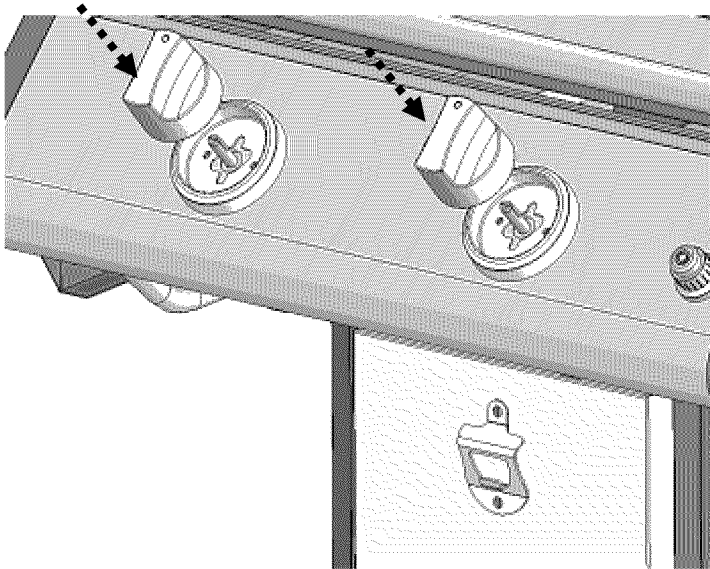

10

Install Side Shelf Supports to Firebox

- Attach Side Shelf Right Front Support and Side Shelf Right Back Support to Firebox using 4 Flat Head Bolts (M6x12mm).
- Attach Side Shelf Left Front Support and Side Shelf Left Back Support to Firebox using 4 Flat Head Bolts (M6x12mm).

Note: Position the supports so that the pins are at the bottom of the supports and extend towards the center of the Firebox.

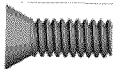

Flat Head Bolt M6x12mm
Qty: 8

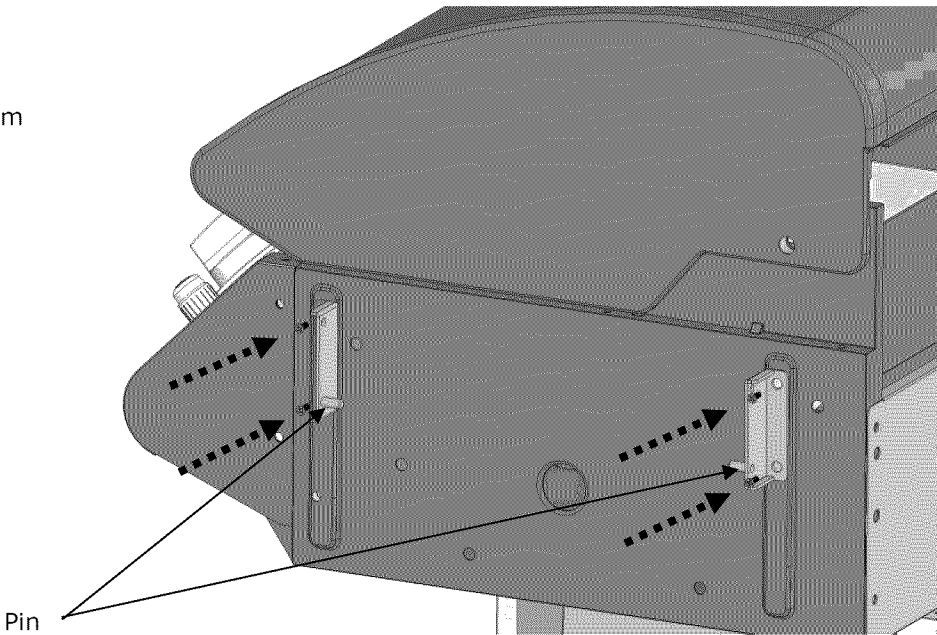

11

Attach Side Shelves

- Position Shelves brackets to the inside of the Shelf supports.
- Attach Left and Right Shelves to Firebox with two Step Bolts (M6) each. Securely tighten bolts.

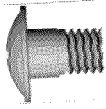

Step Bolt M6
Qty: 4

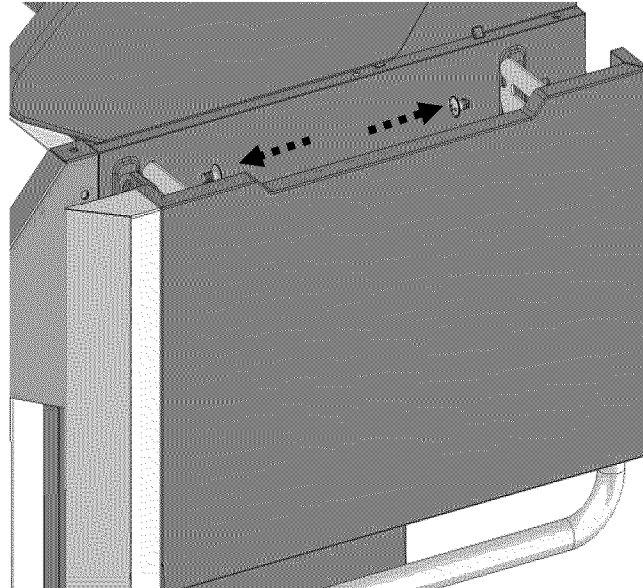

12

Side Shelf Operation

- Pull up on the Left Side Shelf and slide down over the support pins to secure in the upright position. Repeat the same procedure on the Right Shelf. To lower, slide shelves up and fold down into storage position.

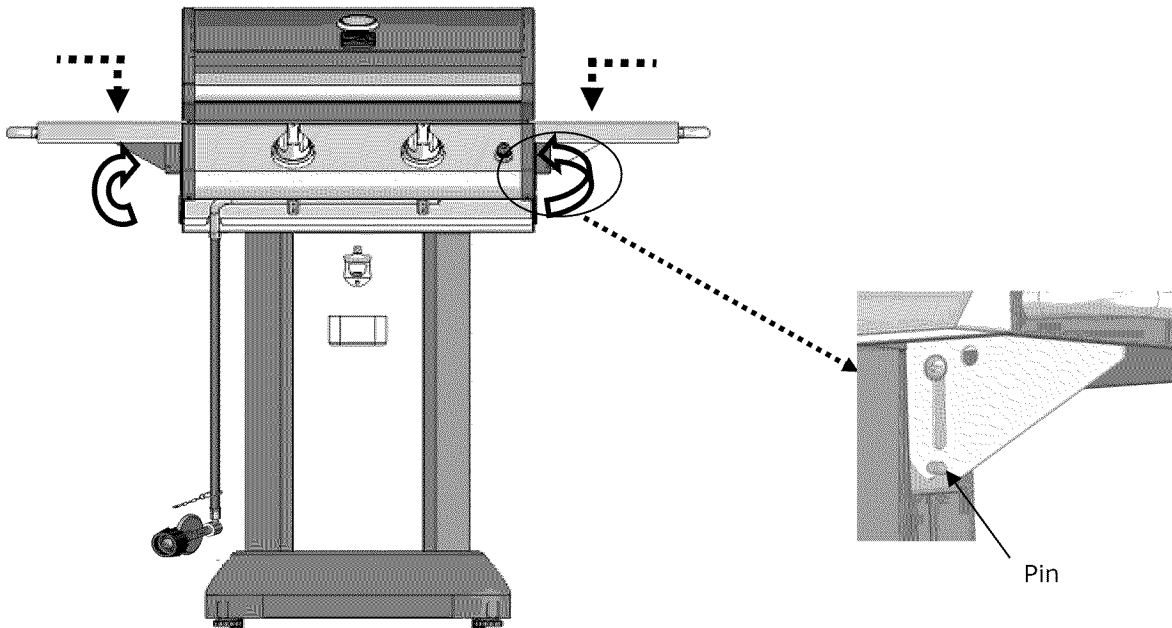

13

Install the Heat Diffusers, Cooking Grates, Warming Rack

- Insert the Heat Diffusers into the firebox by placing them into the indentations along the front and back of the firebox. See Figure 1.
- Place the Cooking Grates into the firebox. See Figure 2.
- Insert the Warming Rack into the slots of firebox side panels as shown. See Figure 3.

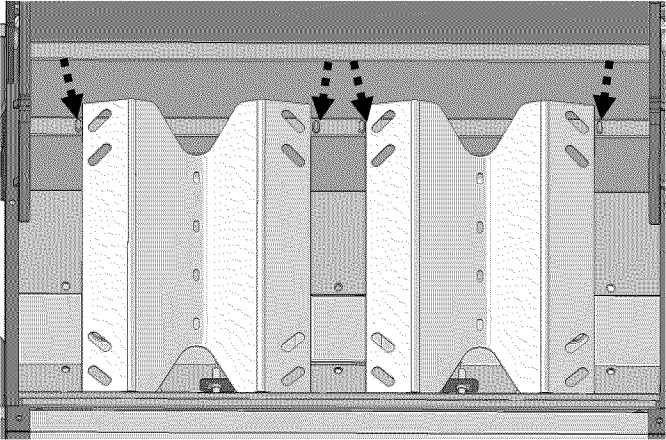

Figure 1

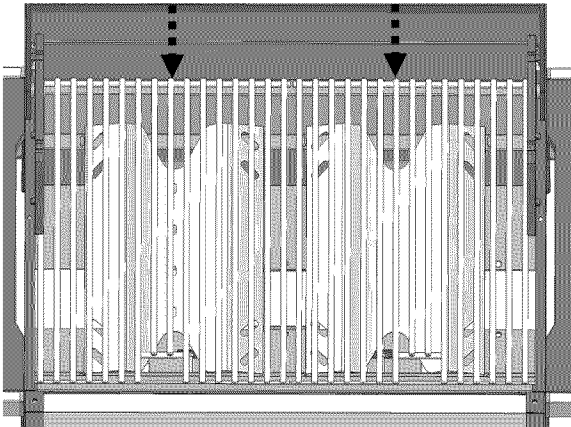

Figure 2

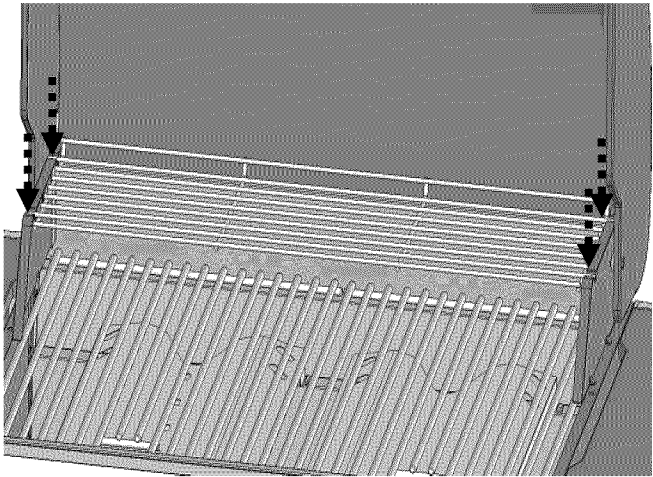

Figure 3



14

Install Grill Transport Handle

- Attach Transport Handle and 2 Handle Heat Shields to the back of the Firebox using 4 Flat Head Bolts (M6x25mm).

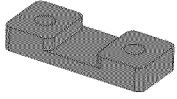

Grill Transport Handle Heat Shield
Qty: 2

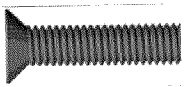

Flat Head Bolt M6x25mm
Qty: 4

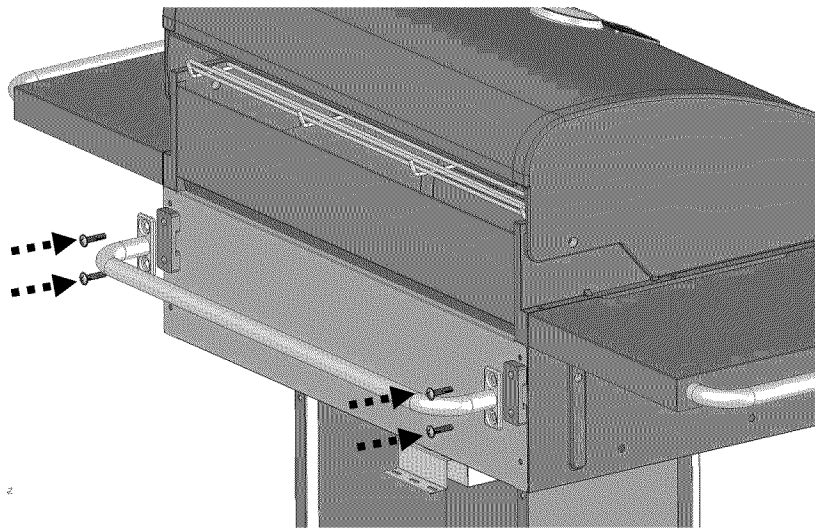

15

Install the Regulator Hose Support Chain

- Attach the Regulator Hose Support Chain (on the regulator hose) to the back of Cabinet Side Panel using 1 Washer Head Bolt (M4x10mm).

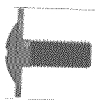

Washer Head Bolt M4x10mm
Qty: 1

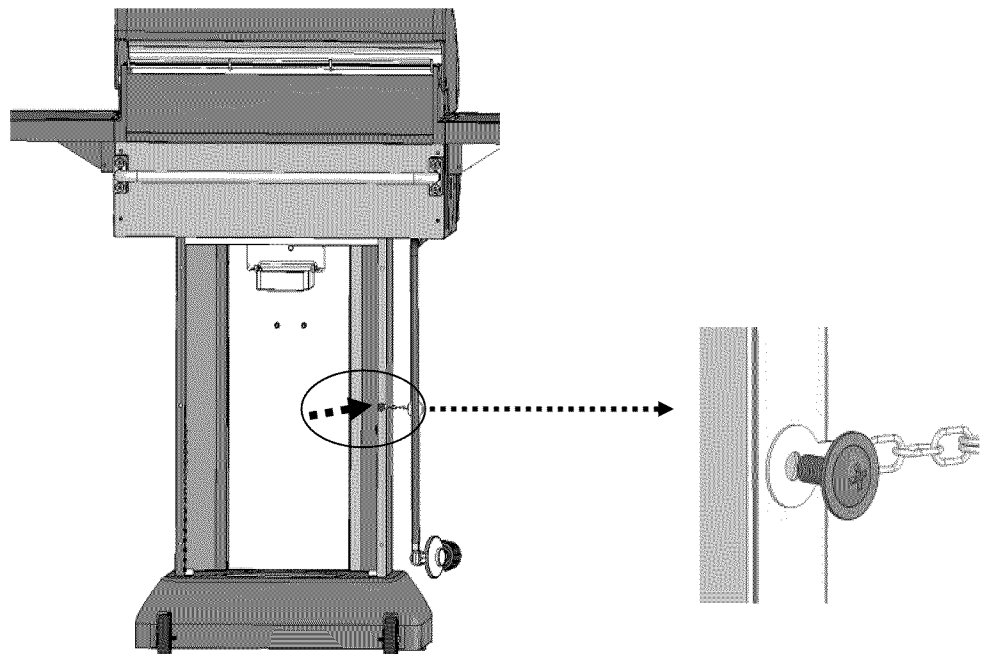

16

Place and Secure LP Cylinder into the Cabinet

- ❑ Be sure the LP cylinder is "OFF" by turning the hand wheel clockwise until it stops. Place the LP cylinder down into the tank support hole in the bottom of the cabinet. Be sure the grill burner controls are turned to the "OFF" position. Remove the safety cap from the cylinder valve. Center the nipple of the grill regulator into the cylinder and turn the black nut clockwise until it stops. Hand tighten only.
- ❑ Hang the propane tank support chain around the LP tank and attach to its hook to secure the tank.



Propane Tank Support Chain
Qty: 1

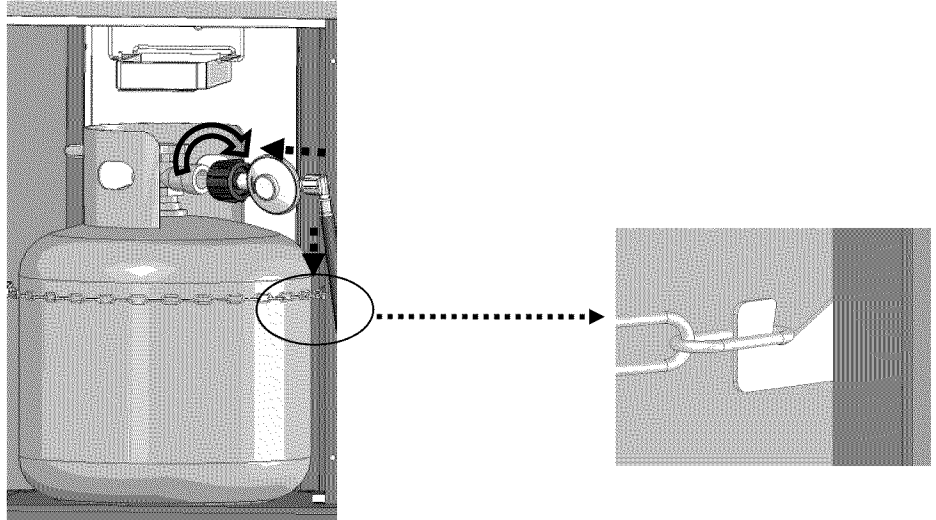

17

Install Battery

- ❑ Unscrew the electronic igniter button. Place the AAA Battery into the igniter with the positive (+) end up. Screw the electronic igniter button back into place.



Battery (Size AAA)
Qty: 1

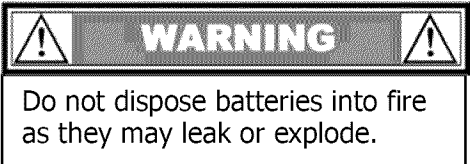
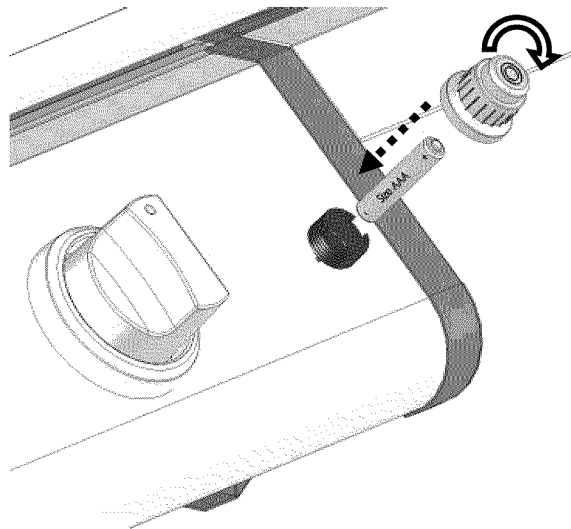

18

Congratulations – Assembly is now complete!

- Remove any additional labels or packing material from the grill except the CSA label. Be sure to clean all foam packing material out of all areas.
- Level your grill by adjusting the 2 front feet.
- Please proceed to and read the remaining sections of the Use & Care Guide prior to operating your grill.

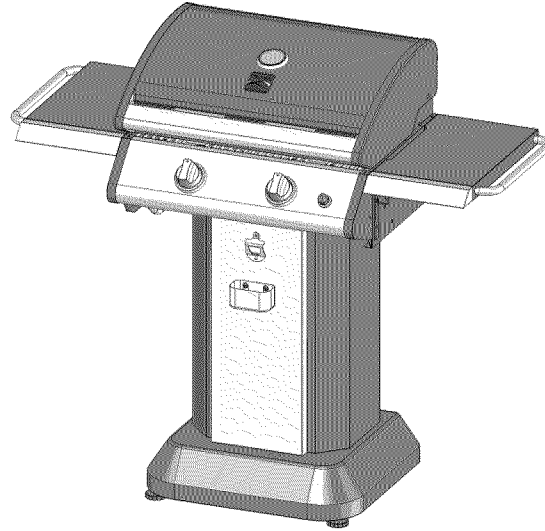

19

Grill Transport

- Grasp Grill Transport Handle with one hand and Grill Hood Handle with the other. Place foot against back of grill base for leverage. Tilt grill back onto wheels to transport.
CAUTION: Grill must be completely cooled down before transporting.

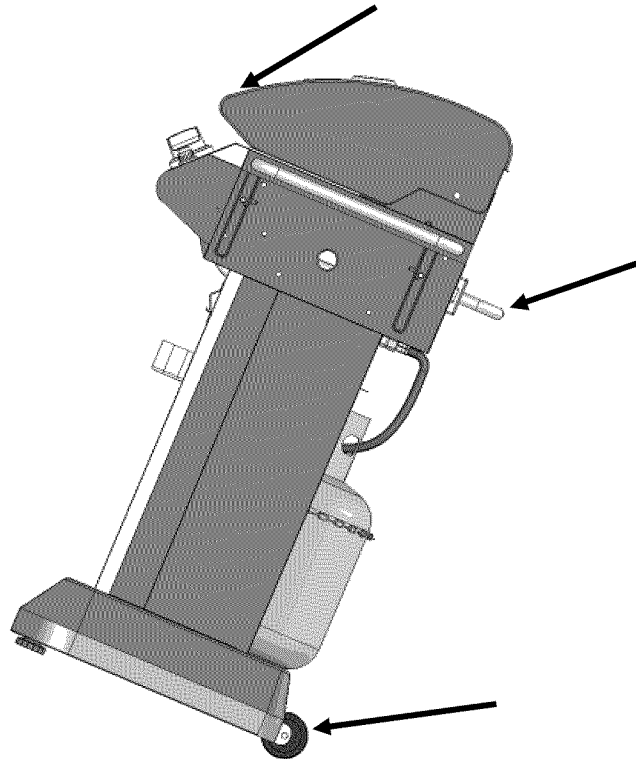

General Information and Instructions

Your new Kenmore Patio Grill has been designed and manufactured to high quality standards. It will provide you with many years of enjoyment with a minimal amount of maintenance. Please keep in mind the following **FOR YOUR SAFETY**.

OPERATION

1. Your gas grill requires reasonable care during operation. It will be hot during cooking and cleaning. You should never leave the grill unattended or move the grill when in use.
2. Children should never use your gas grill. Keep younger children and pets away when in use.
3. Only use your gas grill outside in a well-ventilated area. Never use indoor in any building, garage, shed, or under any type of flammable canopy or overhang.
4. Ensure your grill is on level ground before use.
5. Turn all gas valves off should the burner go out when cooking. Open the lid and wait 5 minutes before relighting.
6. Do not lean over the grill or touch the edges of the firebox or lid when in use.
7. Turn the burners off, close the lid, and shut off the LP cylinder should a grease fire occur.
8. Do not obstruct the flow of combustion and ventilation air to this grill.
9. Keep the ventilation openings of the cylinder enclosure free and clear from debris.
10. Keep the outdoor cooking gas appliance area clear and free from combustible materials, gasoline, and other flammable vapors and liquids.
11. Do not put a grill cover or other flammable material in the storage area of this grill.
12. Do not use charcoal briquettes, lava rock, or any type of ceramic product in this grill.

LP Gas and Cylinder Information

Your new gas grill operates on LP (Liquefied Petroleum) gas. LP gas is odorless, colorless, and non-toxic when produced. You can smell LP gas as it has been given an odor similar to rotten cabbage for your safety.

Your grill uses the newest and safest LP Gas Cylinder. It must meet the following requirements:

1. 20-pound (9.1kg) propane cylinder.
2. Measurements: 12-1/2 in. (317mm) in diameter and 18-1/2 in. (472mm) in height.

In addition, the LP Gas Cylinder to be used must be or have:

- Constructed and marked with U.S. Department of Transportation (D.O.T.) for the US or CAN/CSA-B339, Cylinders, Spheres and Tubes for Transportation of Dangerous Goods; and Commission, for Canada.
- A listed overfilling prevention device (OPD). A triangular hand wheel identifies this feature. **Only use LP gas cylinders with this type of valve.**
- Type 1 quick connect valve for cylinder connection.
- A safety release valve.
- A means for vapor withdrawal.
- A collar to protect the tank valve.

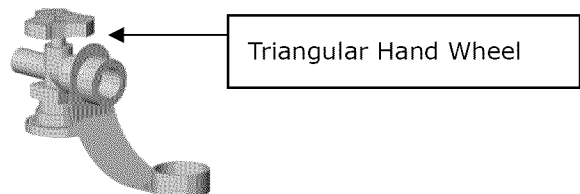

	WARNING	
Do not attempt to use a cylinder with any other type of connection device.		

LP CYLINDER FILLING AND EXCHANGE

Some areas of the country only allow you to exchange your empty cylinder for a replacement that is already full. Other areas allow you to refill your cylinder. If you are in an area where you can refill your cylinder:

- Use only a licensed dealer.
- The dealer must first purge a new cylinder before filling.

- Never fill a cylinder more than 80% full by weight. Volume will vary by temperature. An empty cylinder weighs approximately 18 pounds (8.2kgs).
- Be sure the LP dealer checks the cylinder for leaks after filling.
- Do not release LP gas into the atmosphere as it can unexpectedly ignite when mixed with air.
- Contact an LP dealer to remove LP gas from a cylinder.

WARNING

A frosty cylinder valve indicates possible gas overfill. Close the LP valve and call your dealer immediately.

WARNING

1. Never store any extra cylinders under or near your grill.
2. Never fill your cylinder over 80% full by volume. This may cause release of gas from the safety release valve.
3. If the information in "1" and "2" is not followed exactly, a fire causing death or serious injury may occur.
4. Immediately call your LP dealer or fire department should you hear or smell escaping gas.
5. Keep cylinders out of direct sunlight and high heat.
6. Do not insert any type of foreign objects into the valve outlet.

For Your Safety

- The gas supply must be turned off at the LP gas supply cylinder when this gas grill is not in use.
- Storage of this gas grill indoors is permissible only if the cylinder is disconnected and removed from the gas grill.
- Cylinders must be stored outdoors out of reach of children and must not be stored in a building, garage, or any other enclosed area.

LP CYLINDER LEAK TEST

A leak test should be done each time a cylinder is refilled or exchanged. Do not smoke or use any type of flammable material in the area during this leak test.

Do not use an open flame to check for leaks.

- Test outside in a well - ventilated area.
- Use a paintbrush and a solution of 50% liquid soap and 50% water. Do not use cleaning agents as they can damage the fuel supply parts.
- Brush liquid onto areas highlighted with arrows.
- Bubbles indicate a leak.

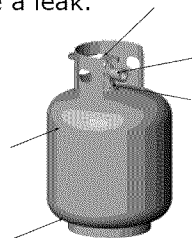

WARNING

Bubbles indicate a leak. In that case, call your LP dealer or fire department immediately.

TRANSPORTATION AND STORAGE

- Place the dust cap on the cylinder valve outlet whenever the cylinder is not in use. Only install the type of dust cap on the cylinder valve outlet that is provided with the cylinder valve. Other types of caps or plugs may result in leakage of propane.
- Do not smoke when transporting your cylinder.
- Keep cylinders out of direct sunlight and away from sources of heat.

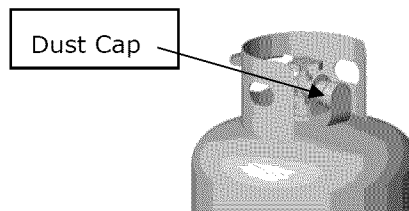

WARNING

Keep the gas cylinder in the upright position at all times to allow for vapor withdrawal. Always keep gas cylinders upright for transportation and storage.



REGULATOR AND LP CYLINDER CONNECTIONS

CAUTION

The pressure regulator and hose assembly provided with this gas grill must be used. This regulator is set for an outlet pressure of 11 inches water column. Replacement pressure regulators and hose assemblies must be those specified in the parts list.

Your regulator is equipped with a Q.C.C. Type 1 quick connect system. It will not allow gas to flow until a positive seal has been made. It has a flow-limiting device that will restrict the flow of gas to 10 cubic feet per hour (0.28 cubic meters per hour).

TO PLACE THE CYLINDER INTO THE GRILL CABINET

1. Place the LP tank cylinder in the cabinet. Base front of the tank valve should face out from the enclosure.
2. Wrap the tank support ring around the tank and latch over its hook to secure the tank.

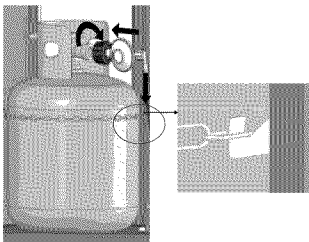

TO CONNECT THE CYLINDER TO THE REGULATOR AND HOSE

1. Place the cylinder into the cabinet following the information in the assembly instructions.
2. Be sure the LP cylinder is "OFF" by turning the hand wheel clockwise until it stops.
3. Be sure the burner controls are turned to the "OFF" position.
4. Remove the safety cap from the cylinder valve.
5. Center the nipple of the regulator into the cylinder.
6. Turn the black nut clockwise until it stops.
Hand Tighten Only. Do Not Use A Wrench.

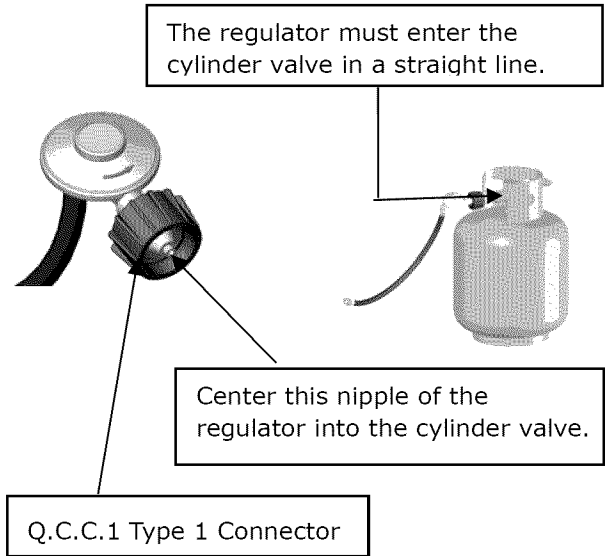
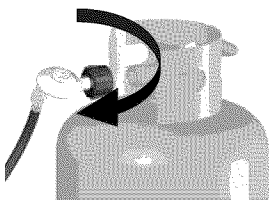

WARNING



Keep the gas cylinder in the upright position at all times.



WARNING



- Do not connect this grill to any unregulated sources of propane.
- Before each use, check the gas hose for excessive abrasion or wear, or cuts. Replace a hose assembly showing those signs with the hose assembly specified in the parts list before using the grill. Inspect the hose assembly by following it from the LP tank connection to the gas manifold assembly.
- Always perform the Leak Test listed below before using your grill for the first time, if the cylinder has been changed, any gas components have been changed, the regulator flow-limiting device has been activated, or after a long period of non-use.
- Do not attempt to connect this grill to the LP system of a motor home or trailer.

LEAK TESTING THE REGULATOR, VALVES, HOSES, AND CONNECTIONS

1. Ensure the LP cylinder valve and burners are "OFF".
2. Ensure the LP cylinder is connected to the regulator.
3. Mix up a solution of 50% water and 50% liquid dish soap. Do not use any household cleaner solution.
4. Open the LP tank valve by turning the hand wheel counterclockwise. If you hear a rushing sound, turn the gas off immediately. In that case, there could be a leak at the connection. Reconnect the cylinder to the regulator.
5. Spray or brush on the solution covering the following areas: cylinder welds, regulator and cylinder connection, gas hose connection to the regulator, gas hose, the gas hose connection to the gas manifold assembly, and the valve connections to the gas manifold pipe.
6. Growing bubbles on any of the parts and connections listed above indicate a gas leak. Immediately shut off the LP tank valve by turning the valve clockwise. Retighten the connections or order replacement parts as needed. Continue to test as necessary until no leaks are detected.
7. Close the LP tank valve after testing by turning the hand wheel clockwise.

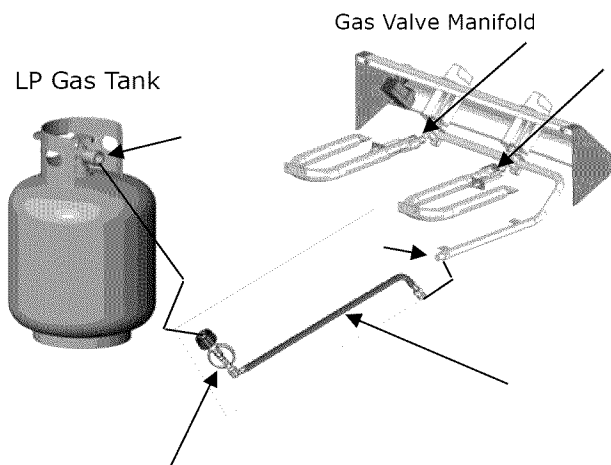

CAUTION

Never face your grill opposite the wind direction. Wind coming from behind the grill may make lid handle hot to touch.

! **WARNING** !

- **DO NOT USE THE GRILL** if you cannot stop a leak. Be sure the LP cylinder valve is closed. If the LP cylinder is still leaking, contact your LP dealer or local fire department.
- Do not use any match or open flame, or smoke, during leak testing.
- Do not light a burner during leak testing.
- The replacement hose assembly must be the one identified in the Parts List of this manual.

GRILL PLACEMENT

For Your Safety

- Minimum clearance required from sides and back of unit to adjacent combustible construction is 36 inches (91 cm).
- Do not locate or use this outdoor cooking gas appliance under overhead combustible surfaces.
- Maintain at least 10 feet (305cm) of clearance from objects that can catch fire or sources of ignition such as pilot lights, electrical appliances, etc.

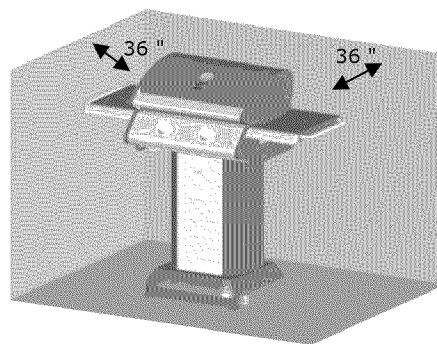

Keep any electrical supply cord and the fuel supply hose away from any heated surfaces and water.

APARTMENT RESIDENTS

Check with your apartment manager regarding your regulations for barbecues. If allowed, use only outside on the ground floor. Do not use on balconies.

GRILL OPERATIONS

BEFORE AND AFTER LIGHTING

- Ensure your grill is located on a level surface and use the adjustable feet as necessary to stabilize.
- Keep the gas grill area clear and free from combustible materials, gasoline, and other flammable vapors and liquids.
- Ensure nothing is obstructing the flow of combustion and ventilation air.
- Ensure the ventilation openings of the cylinder enclosure are free and clear of debris.
- Visually check burner flames.
- Never move the grill when it is hot.

CAUTION

- Never lean over the firebox and burners when lighting the grill.
- Grills are ventilated for safety and performance reasons. Closing the hood on a grease fire will not extinguish the fire.
- Do not put water on a grease fire. If a grease fire starts, turn the control knobs and LP cylinder off. Flour may be used to help smother a grease fire.
- Do not leave a grill unattended when preheating, cooking, or cleaning. A grease fire can occur during these events if grease has been allowed to collect by not regularly cleaning the grill.



WARNING



1. Read instructions before lighting.
2. Open lid during lighting.
3. If ignition does not occur in 5 seconds, turn the burner control knob off, wait 5 minutes and repeat the lighting procedure.

LIGHTING THE MAIN BURNERS WITH ELECTRONIC IGNITION

1. Open the lid.
2. Ensure the burner control knobs are in the "OFF" position.
3. Turn on the LP gas by slowly turning the hand wheel on the cylinder valve.
4. Push in a burner control knob and turn left to  Hi. Immediately press the electronic ignition button for 3 to 5 seconds. You should hear a clicking sound which shows the electronic igniter is working. If burner does not light

within 5 seconds, turn the burner control knob to "OFF". Wait for 5 minutes for the gas to clear and repeat the lighting procedure.

5. Repeat step 4 to light other burner.
6. Follow the match lighting instructions below if burners do not light.
7. When lit, turn the burner control knob to its desired heat setting.

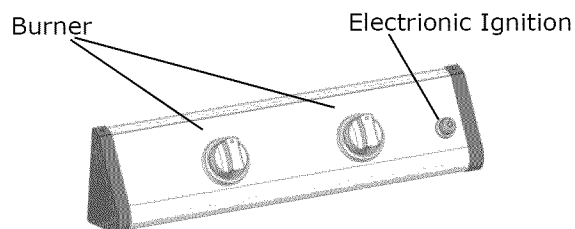

MATCH-LIGHTING A MAIN BURNER

1. Open the lid.
2. Insert a match into the match holder. Ignite the match and insert through the cooking grates and hold next to the burner
3. Push in a burner control knob and turn left to  Hi. Continue to press in on the control knob until the burner ignites. The burner should light immediately.
4. If the burner does not light within 5 seconds, turn the control knob to the "OFF" position, wait 5 minutes for gas to clear and try again.

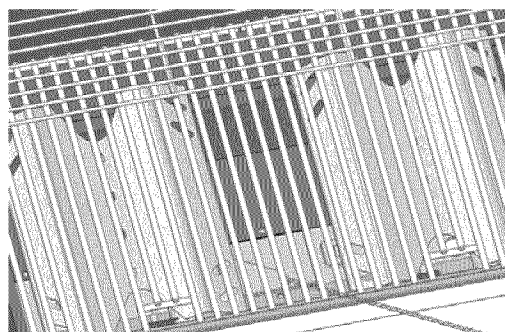

TURNING OFF YOUR GRILL

1. Turn burner control knobs to the "OFF" position.
2. Turn off the gas supply at the LP tank by turning the valve clockwise.

CARE AND MAINTENANCE

WARNING

- Do not clean any part of your barbecue grill in a self-cleaning oven.
- Do not use oven cleaners, abrasive kitchen cleaners, cleaners that contain citrus products, or mineral spirits.
- Do not use any type of steel bristled brush.
- Clean your grill regularly to prohibit grease build-ups and avoid a grease fire or excessive flare-ups.
- Always wear protective gloves when cleaning your grill.

Stainless Steel and Painted Surfaces

Wash with a mild dish soap and warm water. A cloth, soft brush, or plastic cleaning pad can be used. Rinse thoroughly and wipe dry. There are many specific stainless steel cleaners available. Follow the manufacturer's directions. Always polish in the direction of the lines. Do not allow dirt and grease to accumulate. Do not use steel wool, as it will scratch the surface.

In addition, the following products and naturally occurring substances in the outdoors will damage all stainless steel finishes. Use caution so that they do not come in contact with your gas grill. Immediately wash them off and dry the stainless steel should they ever come in contact with your Gas Grill. These include, but are not limited to, Pool Chemicals (chlorine and bromine), Lawn Fertilizer, Ice Melting Salts, Sea or Salt Water, Urine, Bird Droppings, and Tree Sap. **Store your grill 50 to 100 feet away from a pool as many pool chemicals will cause rust.**

Porcelain Surfaces

Use a baking soda and water solution or nonabrasive scouring powder for stubborn stains.

Cooking Grates, Warming Rack, and Heat Diffusers

Use a stiff brass brush. Wash with warm water and mild dish soap as needed, rinse, and dry.

Electronic Igniter

Visually inspect for cracks. Replace if a crack is found. Do not use water to clean the igniter.

Electronic Ignition Maintenance

Your grill is equipped with electronic ignition. It's powered by one AAA size battery. Replace the battery when necessary. Unscrew the igniter top. Place the new battery into the igniter with the positive (+) end of the battery facing up. Screw the igniter top back into place.

WARNING

- Batteries will deteriorate over time. This can cause their casings to leak.
- Remove the battery from the electronic ignition when storing your grill.
- Check the condition of the battery periodically before use.

Burners

We recommend you clean your burners at least twice a year, or before use if the grill has not been used in over one month.

WARNING

For safe operation ensure the gas valve assembly orifice is inside the burner tube before using your grill. See figure. If the orifice is not inside the burner tube, lighting the burner may cause explosion and /or fire resulting in serious bodily injury and /or property damage.

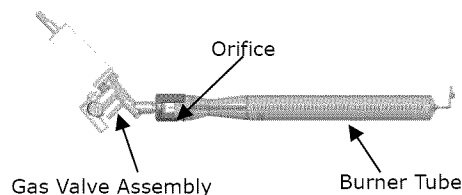

WARNING

Small insects and spiders are able to access the burner tubes. Sometimes they will build nests or spin webs. In either case, this can block or reduce the amount of gas flowing through the burner. You will usually see a smaller flame, or a flame that is mostly yellow rather than blue, coming from the burner when this happens. Other signs include the grill not heating evenly, not reaching temperature, or burners not igniting. In cases with severe blockage, this can cause the flame to burn backwards, and outside of the burner tubes, which can cause damage to your grill and/or personal injury. **IMMEDIATELY SHUT OFF THE FLOW OF LP GAS AT THE CYLINDER BY TURNING THE HAND WHEEL CLOCKWISE SHOULD THIS HAPPEN.** Wait for the grill to cool, and then clean all burners.



When to Look for Spiders

You should inspect the burners at least twice a year or immediately after any of the following conditions occur:

1. The smell of gas in conjunction with burner flames appearing yellow.
2. The grill does not reach the temperature.
3. The grill heats unevenly.
4. The burners make popping noise.

Cleaning the Main Burners

1. Ensure the LP gas is turned off at the LP cylinder.
2. Remove the cooking grates and heat diffusers.
3. Remove the Phillips head screws located at the back end of each burner.
4. Lift each burner up and out.
5. Clean the inside of the burner using a stiff wire. A straightened coat hanger is one suggested tool. An alternative way to clean the inside of the burner is using compressed air. Always wear eye protection if using this method. **Never enlarge the burner ports during cleaning.**
6. Brush the outer surface of the burner.
7. Ensure all ports (holes) are free of all debris.
8. Inspect the burner. Replace if any cracks or enlarged holes.
9. Reinstall the burners making sure the burners seat over the valves as shown in the figure below.
10. Secure the back of the burners to the firebox with the Phillips head screws.
11. Replace the heat diffusers and cooking grates.
12. Perform a Leak Test described earlier in this guide.

WARNING

Properly locating the burner with respect to the orifice is vital for safety.

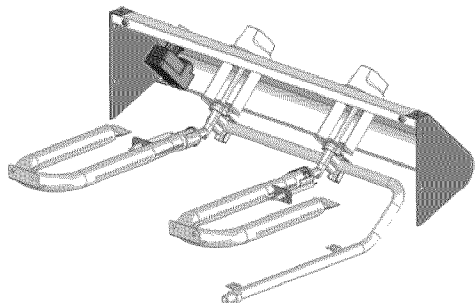

Burner Flames

Always inspect the burner flame after lighting. A good flame should be primarily blue with a yellow tip and have a minimal amount of noise. Some yellow tips are OK if under one inch.

New burners sometimes have oil residue, which will cause yellow flame when burning off. Variations in gas supply, altitude, weather, and other factors can all impact burner performance.

Older grills can also show more yellow flame as food deposits, oils, and fats can build up.

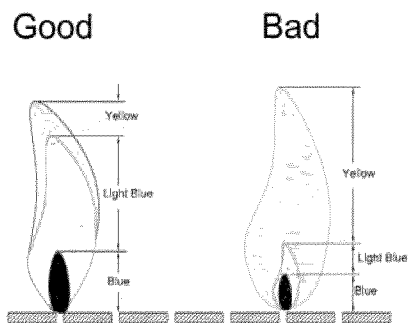

Always

1. Keep the grilling area clear and free from combustible materials, gasoline and other flammable vapors and liquids.
2. Do not obstruct the flow of combustion and ventilation air.
3. Keep the ventilation openings of the cylinder enclosure free and clear from debris.

Grill Storage

1. Clean your grill before storage.
2. Storage of a gas grill indoors is permissible only if the cylinder is disconnected and removed from the gas grill.
3. Remove the battery from the electronic ignition.
4. Cover the grill.
5. Perform a Leak Test before use after storage.

Grilling With Your New Grill

Welcome to the world of grilling. Whether you're already an established griller, or just starting out, your new grill should bring you much enjoyment and satisfaction, not to mention some phenomenal meals. We encourage you to experiment to find your own favorite recipes.

The control panel is labeled "Hi", "Low", and "OFF" for main burner control. Simply push in on the temperature control knob and turn to the desired heat setting. A thermometer is placed in the hood so that you can see the cooking temperature inside the grill.

The heat diffusers are designed to help evenly distribute heat throughout the grill. They are also designed to catch and smoke the right amount of drippings, adding more flavors to your meal.

DIRECT VS. INDIRECT COOKING

Food cooked on the grill is either done using direct or indirect cooking. Direct cooking is when the food is cooked directly over lit burners. Food is placed in-between the lit burners for indirect cooking.

DIRECT – used for preheating and searing

Use direct cooking to sear meats. This helps to keep food moist by locking in juices. Some food, such as steak, is first seared using direct cooking, and then finished cooking using the indirect method. This is generally used for quicker cooking foods. Preheat the grill on "Hi" 5 to 10 minutes. Place the food directly over the heat source. Remain vigilant when grilling using this method, as it's easy to overcook.

INDIRECT – how most food is cooked on a gas grill

Indirect cooking is used for foods that take longer to cook, including large cuts of meat such as roasts. It's also used for cooking more delicate food that can dry out quickly such as fish and poultry, for fattier foods to reduce flare-ups, and when grilling using a roasting pan or aluminum foil. Preheat the grill on "Hi" 5 to 10 minutes. Then turn to medium or low depending on the temperature you want to maintain. Generally, you want to keep the temperature around 350°F. Do not place the food directly over any burners when using this grilling method. You can also grill indirectly by turning one burner off and placing

KNOWING WHEN THE FOOD IS DONE

We strongly recommend using a meat thermometer. Food cooked on a grill can brown very fast on the outside, well before it's cooked on the inside. Many factors can influence cooking times, including wind, outdoor temperatures, and altitude. Therefore, it's best to use a meat thermometer to ensure your food has cooked long enough. Check with your specific recipe, but for general guidelines:

1. Hamburgers, sausages, and all ground meat should reach 160°F (71°C).
2. Beef should reach 145°F (63°C) for medium rare.
3. Veal should reach 160°F (71°C) for medium and lamb should reach 145°F (63°C) for medium rare.
4. Pork should reach 160°F (71°C).
5. Poultry should reach 180°F(82°C), or 170°F(77°C) for boneless pieces.

GRILLING TIPS AND TRICKS

1. Always "Preheat" your grill before cooking. Turn to "Hi" and close the lid. You will want to preheat until the thermometer reads over 400F (204°C), which should be 5 to 10 minutes. Then adjust the burner control knobs to the proper temperature.
2. The thermometer measures the temperature at the top of the lid. The temperature down by the cooking grates is somewhat warmer.
3. Mother Nature can impact your grilling times. Allow more cooking time for cold, wind, and higher altitudes. We recommend you place the grill in an area protected from much wind.
4. Trim away any excess fat from meat to reduce flare-ups.
5. Keep similar size portions together so that they cook more evenly.
6. Generally speaking, the more food on the grill, the longer the cooking time.
7. Be aware when using the direct cooking method, as food can easily become overcooked, burned, or dry out. Food may require more turning, or sometimes, may need to be moved off the flame.
8. Larger pieces of meat generally require more cooking time per pound than smaller pieces of meat.
9. If a major flare-up, or too many flare-ups occur, turn off the gas, move the food away from the flare-up, and close the hood. Restart the grill once the flare-up has died down.

10. Turn foods infrequently. Generally, only turn a steak once during cooking.
11. Use tongs rather than a fork when turning the food on the grill. Less juice will be lost that way.
12. Know your sauce and when to apply. Oil and vinegar based sauces can be brushed on any time. Sugar based sauces like barbecue sauce should be applied during the last few minutes of cooking.
13. A timer can help you keep from over-cooking the food.
14. Use insulated protective mitts or potholders when working around a grill in operation.
15. Use a small amount of cooking oil on the cooking grates before heating to reduce foods sticking on the grates.

FOOD SAFETY

1. Always use safe food handling and preparation when using this grill.
2. Wash all poultry, seafood, and vegetables before cooking.
3. Use separate platters, plates, and utensils for uncooked and cooked foods.
4. Leave all meat, poultry, and seafood in the refrigerator until ready to cook.
5. Use a meat thermometer to ensure foods are adequately cooked.

Trouble Shooting Guide

BURNER WILL NOT LIGHT

1. Gas supply is turned off. Turn on gas at LP cylinder.
2. Out of propane. Check to be sure you still have propane in your tank.
3. Regulator is not properly seated into the tank valve. Remove and reattach. Hand tighten only.
4. Crimped fuel supply hose. Inspect and straighten.
5. Regulator failure or damaged hose. Order replacement part and replace.
6. Make sure you can hear the electronic igniter clicking. If not, replace the battery with an AAA size. Inspect the electrode to be sure it's not coated in grease or dirt. If so, clean with rubbing alcohol. Check the distance from the electrode tip to the burner. The tip of the electrode should be 1/8" to 1/4" from the main burner. Adjust if necessary. Inspect the electrode to be sure it's not cracked or broken. If so, order replacement parts and replace.
7. Blockage in the gas system. Inspect the burner to be sure insects, spider webs, etc do not block them. Clean if necessary. Inspect under the control panel to be sure the burner are aligned properly with the valves.

IRREGULAR FLAME OR YELLOW FLAME

1. New burner may have residual oil, which will burn off.
2. Tubes in burners are blocked. Remove and clean.
3. Burner has a high grease or dirt build-up. Remove and clean.
4. Burner is not aligned properly with the valves. Inspect under the control panel.

SUDDEN DROP IN GAS PRESSURE OR FLAMES BLOW OUT

1. Out of gas. Check to be sure you still have propane in your tank.
2. Your excessive fuel flow valve has tripped, thereby reducing the flow of gas. Turn off all burners, wait 30 seconds, and relight grill. If problem persists, turn off all burners. Disconnect regulator from tank. Wait 10 minutes. Reconnect regulator and leak test. Slowly turn on LP tank and relight grill. Other ways the flow limiting device can be activated include
 - a. A ruptured gas hose. Inspect, perform a leak test, and replace as necessary.

- b. Opening the control knob before turning on the LP gas at the cylinder. Turn on the gas at the LP cylinder first before turning on a control knob to light.
 - c. Improper purging of cylinder before it was filled. See your LP gas dealer.
3. Wind could be blowing out your burner. Turn front of grill to face wind or move out of the wind.

EXCESSIVE FLARE-UPS

1. Heat diffuser, inside of grill, grates, and burners need to be cleaned.
2. Grease tray needs to be cleaned and emptied.
3. Using too high of heat to cook. Reduce control knob setting.
4. Direct cooking method will produce more flare-ups than indirect. If using direct method, try using indirect.

FIRE BEHIND CONTROL PANEL

Immediately shut off cylinder valve and allow grill to cool.

1. Check burner for obstructions and clean.
2. Inspect under the control panel to be sure the burners are aligned properly with the valves.
3. Gas is leaking from a faulty connection or damaged hose. Perform a leak test and inspect for leaks. Tighten or replace parts as necessary.

Frequently Asked Questions

Can I convert my gas grill from one fuel source to another?

No. Your gas grill is manufactured to specific standards developed by CSA and ANSI for your safety and grilling performance for LP Gas. We do not offer conversion kits nor do we recommend you change the fuel type.

How are your grills tested?

Our grills are tested and certified by CSA, a leading worldwide independent testing center, to meet or exceed various CSA and ANSI standards along with various performance standards. The burners and gas line in each grill are also individually tested when each grill comes off the assembly line just prior to packaging. Each burner is ignited for this test.

What is the humming noise I sometimes here coming from my regulator?

The humming sound you can hear is just gas flowing through the regulator. There is no need to be concerned with a low volume of noise.

My grill has a low flame on some burners, or some burners will not light at all. What can cause this?

This can be caused by the regulator's flow limiting device, which is generated by a sudden change in pressure. Opening the tank valve too quickly can cause this. In this case, close the LP tank valve and disconnect from the regulator. Let it stand for 10 minutes. Reconnect the regulator to the LP tank. Open the grill lid. Slowly open the LP tank valve. Follow the burner lighting procedures and light the burner furthest from the LP tank. Continue to light the other burners as you move towards the LP tank.

Can I use ceramic plates, briquettes of any kind, or lava rocks?

No. Your grill is designed for use only with heat diffusers. Grease drips down on to the diffusers and is burned, creating steam and additional flavor.

Repair Protection Agreements

Congratulations on making a smart purchase. Your new Kenmore® product is designed and manufactured for years of dependable operation. But like all products, it may require repair from time to time. That's when having a Repair Protection Agreement can save you money and aggravation.

Here's what the Repair Protection Agreement* includes:

- ☑ **Expert service** by our 10,000 professional repair specialists
- ☑ **Unlimited service and no charge** for parts and labor on all covered repairs
- ☑ **Product replacement** up to \$1500 if your covered product can't be fixed
- ☑ **Discount of 10%** from regular price of service and related installed parts not covered by the agreement; also, 10% off regular price of preventive maintenance check
- ☑ **Fast help by phone** – we call it Rapid Resolution- phone support from a Sears representative, Think of us as a “talking owner’s manual.”

Once you purchase the Repair Protection Agreement, a simple phone call is all that it takes for you to schedule service. You can call anytime day or night, or schedule a service appointment online.

The Repair Protection Agreement is a risk-free purchase. If you cancel for any reason during the product warranty period, we will provide a full refund.

Or, a prorated refund anytime after the product warranty period expires. Purchase your Repair Protection Agreement today!

Some limitations and exclusions apply. For prices and additional information in the U.S.A. CALL 1-800-827-6655.

***Coverage in Canada varies on some items. For full details call Sears Canada at 1-800-361-6665**

Sears Installation Service

For Sears professional installation of home appliances, garage door openers, water heaters, and other major home items, in the U.S.A. or Canada call **1-800-4-MY-HOME®**

Repair Protection Agreements

Felicitaciones por su compra inteligente. Su nuevo producto Kenmore® viene diseñado y manufacturado para confiables operaciones por años. Pero, como todo producto, puede requerir reparaciones de vez en cuando. Allí es cuando un Acuerdo de Protección de Reparación puede ahorrar su dinero y agravamiento.

A continuación son los elementos del Acuerdo :

- ☑ Servicio de experto por nuestros 10,000 especialistas de reparación.
- ☑ Servicio sin límite y cero cambio de piezas y mano de obra en todas las reparaciones.
- ☑ **Repuesto de producto** hasta a \$1500 si su producto amparado no se puede arreglar
- ☑ 10% de descuento del precio regular de servicio y piezas relacionadas con el servicio que no sean cubiertas por el acuerdo y, 10% de descuento del precio regular de la preventiva revisión de mantenimiento.
- ☑ **Ayuda inmediata por teléfono** – le decimos Teléfono de Resolución Rápida – entregada por un representante de Sears. Piense en nosotros como un “Manual de Usuario Parlante.”

Una vez Ud. compre el Acuerdo, todo lo que necesita es una llamada telefónica para programar el servicio. Ud. puede hacer la llamada en el día o en la noche, o programar una cita para servicio.

El Acuerdo de Protección por Reparación se trata de una compra libre de riesgos. Si Ud. cancela la compra por cualquier razón durante el período de la garantía del producto, le reembolsamos todo el costo. O, un reembolso proporcional en cualquier momento luego de la fecha de vencimiento de la garantía del producto. ¡Compre su Acuerdo de Protección por Reparación hoy!

Algunas limitaciones y exclusiones serán aplicadas. Por precios y mayor información en E.U., llamar a 1-800-827-6655.

*** La garantía puede variar para algunos artículos en Canadá. Para mayor información, llamar a Sears Canada en-800-361-6665**

Servicio de Instalación Sears

Por la instalación profesional Sears de aparatos domésticos, abrepuertas de garage, calentadores de agua y otros grandes artículos domésticos en E.U. o Canadá, llamar a **1-800-4-MY-HOME®**

Get it fixed, at your home or ours!

Your Home

For expert troubleshooting and home solutions advice:

manage  home

www.managemyhome.com

For repair – **in your home** – of **all** major brand appliances, lawn and garden equipment, or heating and cooling systems, **no matter who made it, no matter who sold it!**

For the replacement parts, accessories and owner's manuals that you need to do-it-yourself.

For Sears professional installation of home appliances and items like garage door openers and water heaters.

1-800-4-MY-HOME[®] (1-800-469-4663)

Call anytime, day or night (U.S.A. and Canada)

www.sears.com www.sears.ca

Our Home

For repair of carry-in items like vacuums, lawn equipment, and electronics, call anytime for the location of your nearest

Sears Parts & Repair Service Center

1-800-488-1222 (U.S.A.) **1-800-469-4663** (Canada)

www.sears.com www.sears.ca

To purchase a protection agreement on a product serviced by Sears:

1-800-827-6655 (U.S.A.) **1-800-361-6665** (Canada)

Para pedir servicio de reparación a domicilio, y para ordenar piezas:

1-888-SU-HOGAR[®]
(1-888-784-6427)

Au Canada pour service en français:

1-800-LE-FOYER^{MC}
(1-800-533-6937)
www.sears.ca

Sears

® Registered Trademark / TM Trademark / SM Service Mark of Sears Brands, LLC
© Marca Registrada / TM Marca de Fábrica / SM Marca de Servicio de Sears Brands, LLC
^{MC} Marque de commerce / ^{MD} Marque déposée de Sears Brands, LLC

© Sears Brands, LLC

