



PRODUCT GUIDE

MODEL 463440109

IMPORTANT: Fill out the product record information below.

Serial Number _____
 See rating label on grill for serial number.

Date Purchased _____

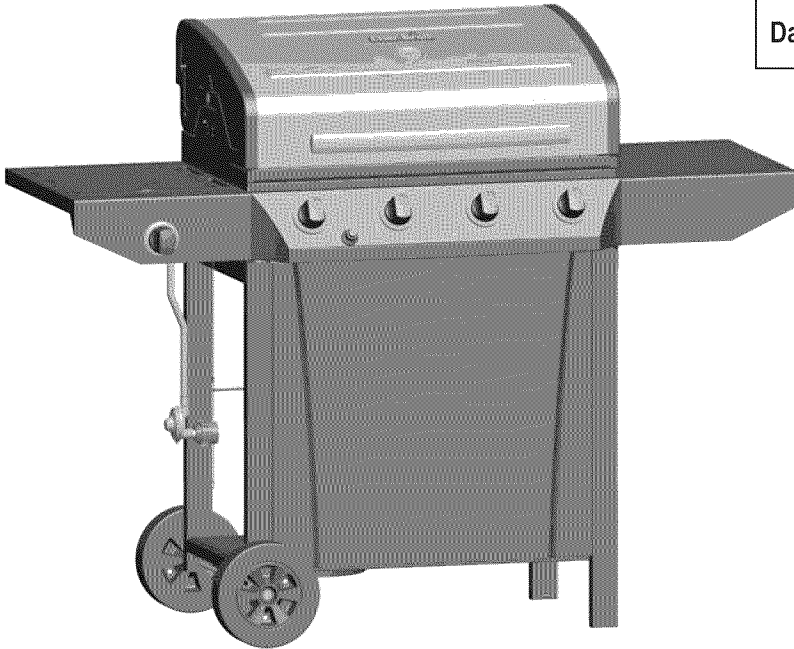

For support and to register your grill, please visit us at www.charbroil.com

If you have questions or need assistance during assembly, Please call **1-800-241-7548**.

Estimated assembly time: 45 minutes

The following are trademarks registered by W.C. Bradley Co. in the U.S. Patent and Trademark Office: Char-Broil®; America's Legendary Barbeque Company®; American Gourmet®; Bandera®; BrushHawg®; CB940®; Char-Diamonds®; Char-Broil Charcoal/Gas®; DiamondFlame®; Everybody Grills®; Everybody Outside®; FastStart®; Fireball®; Firenzy®; FlavorMaster®; Grill2Go®; Grill2Go® Express®; Grill Lovers®; H2O Smoker®; Keepers of the Flame®; New Braunfels Smoker Company®; Oklahoma Joe's®; Patio Bistro®; Patio Caddie®; Patio Kitchen®; Precision Flame®; Quantum®; Santa Fe®; Sear and Grill®; Sierra®; Signature Series®; The Big Easy®; The Minute Grill®; Trentino®; Wild West Tradition®; and the following marks:



The following are trademarks of W.C. Bradley Co.: Commercial Series™; Designer Series™; Grill2Go® Advantage™; Longhorn™; Double Chef™; QuickSet™; Ready When You Are™; Hog and Yard Bird™; You Bring the Party™; SureFire™; Universal Grill Parts™

TEC™ is a trademark of Tec Infrared Grills.

Protected under one or more of the following U.S. Patents: 4,989,579; 5,421,319; 5,458,309; 5,579,755; 5,996,573; 6,114,666; 6,135,104; 6,209,533; 6,279,566; 6,331,108; 6,484,900; 6,526,876; 6,595,197; 6,640,799; 6,640,803; 6,729,873; 6,739,473; 6,749,424; 6,863,100; 6,935,327; 6,951,213; 6,792,935; 7,047,590; D364,535; D372,637; D373,701; D377,735; D383,035; D397,910; D405,643; D406,005; D406,009; D413,043; D413,229; D414,982; D415,388; D416,164; D416,441; D417,587; D417,588; D422,516; D423,876; D428,303; D430,772; D435,396; D436,004; D438,059; D438,060; D438,427; D439,110; D442,505; D443,179; D443,354; D443,464; D447,384; D447,385; D447,909; D448,610; D448,614; D448,615; D448,616; D448,975; D449,492; D450,544; D451,759; D454,028; D454,031; D455,205; D455,206; D456,202; D456,222; D456,223; D457,789; D458,520; D458,760; D458,802; D459,088; D459,148; D459,149; D459,161; D459,163; D459,586; D459,943; D460,312; D460,313; D460,318; D461,359; D465,123; D465,693; D466,307; D466,439; D466,752; D473,414; D474,371; D477,498; D477,501; D477,504; D477,506; D477,746; D478,471; D478,472; D480,914; D491,410; D494,009; D494,413; D498,523; D500,359; D504,048; D530,098; D535,000; Canada: 87,743; 87,744; 97,504; 99,355; 102,037; 104,200; 2,315,567; 2,336,036; France: 010,231; 010,422; 010,590; 010,849; 1,089,646; Germany: 1,089,646; South Korea: 384,565; China: 99,127,066.5; United Kingdom: 2,099,402; 1,089,646. Other Patents Pending.

©2008 W.C. Bradley Company

TM REVISION 00







TABLE OF CONTENTS



| | |
|------------------------|-------|
| For Your Safety | 2-3 |
| Use and Care | 4-9 |
| Grilling Guide..... | 10-13 |
| Limited Warranty..... | 14 |
| Parts List..... | 15 |
| Parts Diagram..... | 16 |
| Assembly..... | 17-24 |
| Troubleshooting..... | 25-27 |
| Registration Card..... | 31 |



Safety Symbols



The symbols and boxes shown below explain what each heading means. Read and follow all of the messages found throughout the manual.

| | | |
|--|----------------|---|
|  | WARNING |  |
| WARNING: Indicates an potentially hazardous situation which, if not avoided, could result in death or serious injury. | | |

| | | |
|---|----------------|---|
|  | CAUTION |  |
| CAUTION: Indicates a potentially hazardous situation or unsafe practice which, if not avoided, may result in minor or moderate injury. | | |

| | | |
|---|---------------|---|
|  | DANGER |  |
| DANGER: Indicates an imminently hazardous situation which, if not avoided, will result in death or serious injury. | | |

| | | |
|---|---------------|---|
|  | DANGER |  |
| If you smell gas: | | |
| <ol style="list-style-type: none">1. Shut off gas to the appliance.2. Extinguish any open flame.3. Open lid.4. If odor continues, keep away from the appliance and immediately call your gas supplier or your fire department. | | |

| | | |
|--|----------------|---|
|  | WARNING |  |
| <ol style="list-style-type: none">1. Do not store or use gasoline or other flammable liquids or vapors in the vicinity of this or any other appliance.2. An LP cylinder not connected for use shall not be stored in the vicinity of this or any other appliance. | | |

| | | |
|--|----------------|--|
|  | CAUTION |  |
| For residential use only. Do not use for commercial cooking. | | |

THIS GRILL IS FOR OUTDOOR USE ONLY.

 **CAUTION:**
Read and follow all safety statements, assembly instructions, and use and care directions before attempting to assemble and cook.

INSTALLER/ASSEMBLER:
Leave this manual with consumer.

CONSUMER:
Keep this manual for future reference.

 **WARNING:**
Failure to follow all manufacturer's instructions could result in serious personal injury and/or property damage.

 **CAUTION:**
Some parts may contain sharp edges – especially as noted in the manual! Wear protective gloves if necessary.



WARNING



CALIFORNIA PROPOSITION 65

1. Combustion by-products produced when using this product contain chemicals known to the State of California to cause cancer, birth defects, and other reproductive harm.

2. This product contains chemicals, including lead and lead compounds, known to the State of California to cause cancer, birth defects or other reproductive harm.

Wash your hands after handling this product.

Installation Safety Precautions

- Use grill, as purchased, only with LP (propane) gas and the regulator/valve assembly supplied. A conversion kit must be purchased for use with natural gas.
- Grill installation must conform with local codes, or in their absence of local codes, with either the *National Fuel Gas Code, ANSI Z223.1/NFPA 54, Natural Gas and Propane Installation Code, CSA B149.1, or Propane Storage and Handling Code, B149.2, or the Standard for Recreational Vehicles, ANSI A 119.2/NFPA 1192, and CSA Z240 RV Series, Recreational Vehicle Code, as applicable.*
- All electrical accessories (such as rotisserie) must be electrically grounded in accordance with local codes, or *National Electrical Code, ANSI / NFPA 70 or Canadian Electrical Code, CSA C22.1.* Keep any electrical cords and/or fuel supply hoses away from any hot surfaces.
- This grill is safety certified for use in the United States and/or Canada only. Do not modify for use in any other location. Modification will result in a safety hazard.



WARNING



Do not attempt to repair or alter the hose/valve/regulator for any “assumed” defect. Any modification to this assembly will void your warranty and create the risk of a gas leak and fire. Use only authorized replacement parts supplied by manufacturer.



CAUTION



Using pots larger than 6 quarts in capacity could exceed weight limit of the side burner shelf, resulting in failure of grill cart components.

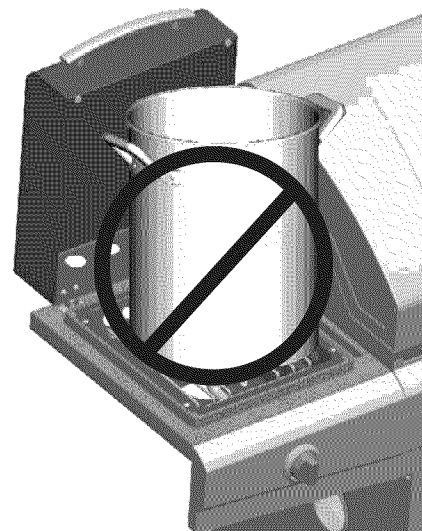

USE AND CARE



DANGER



- **NEVER** store a spare LP cylinder under or near the appliance or in an enclosed area.

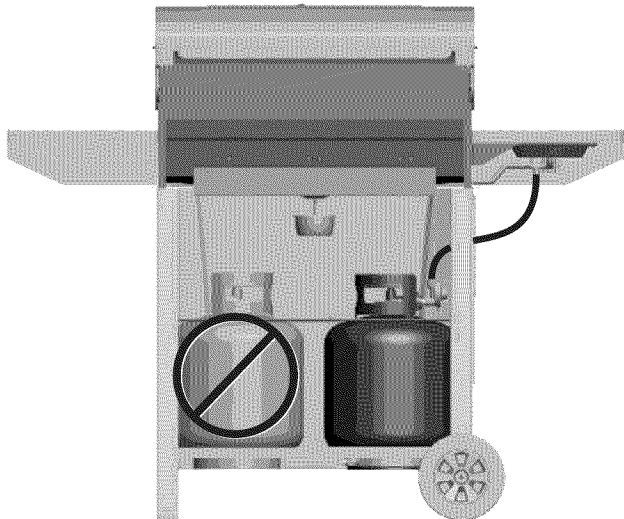

- **Never** fill a cylinder beyond 80% full.
- An over filled or improperly stored cylinder is a hazard due to possible gas release from the safety relief valve. This could cause an intense fire with risk of property damage, serious injury or death.
- If you see, smell or hear gas escaping, immediately get away from the LP cylinder/appliance and call your fire department.

LP Cylinder Removal, Transport and Storage

- Turn OFF all control knobs and LP cylinder valve. Turn coupling nut counterclockwise by hand only - do not use tools to disconnect. Loosen cylinder screw beneath bottom shelf, then lift LP cylinder up and out of cart. Install safety cap onto LP cylinder valve. Always use cap and strap supplied with valve. **Failure to use safety cap as directed may result in serious personal injury and/or property damage.**

- A disconnected LP cylinder in storage or being transported must have a safety cap installed (as shown). Do not store an LP cylinder in enclosed spaces such as a carport, garage, porch, covered patio or other building. Never leave an LP cylinder inside a vehicle which may become overheated by the sun.

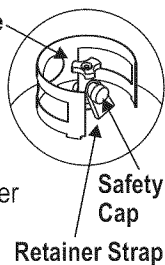

- Do not store an LP cylinder in an area where children play.

LP Cylinder

- The LP cylinder used with your grill must meet the following requirements:

- Use LP cylinders only with these required measurements: 12" (30.5cm) (diameter) x 18" (45.7 cm) (tall) with 20 lb. (9 kg.) capacity maximum.

- LP cylinders must be constructed and marked in accordance with specifications for LP cylinders of the U.S. Department of Transportation (DOT) or for Canada, CAN/CSA-B339, cylinders, spheres and tubes for transportation of dangerous goods. Transport Canada (TC). See LP cylinder collar for marking.

- LP cylinder valve must have:

- Type 1 outlet compatible with regulator or grill.

- Safety relief valve.

- UL listed Overfill Protection

Device (OPD). This OPD safety

feature is identified by a unique triangular hand wheel. **Use only LP cylinders equipped with this type of valve.**

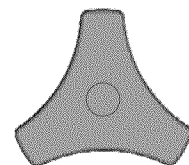

OPD Hand Wheel

- LP cylinder must be arranged for vapor withdrawal and include collar to protect LP cylinder valve. Always keep LP cylinders in upright position during use, transit or storage.



LP cylinder in upright position for vapor withdrawal

LP (Liquefied Petroleum Gas)

- LP gas is nontoxic, odorless and colorless when produced. **For Your Safety**, LP gas has been given an odor (similar to rotten cabbage) so that it can be smelled.

- LP gas is highly flammable and may ignite unexpectedly when mixed with air.

LP Cylinder Filling

- Use only licensed and experienced dealers.

- LP dealer **must purge new cylinder** before filling.

- Dealer should **NEVER** fill LP cylinder more than 80% of LP cylinder volume. Volume of propane in cylinder will vary by temperature.

- A frosty regulator indicates gas overfill. Immediately close LP cylinder valve and call local LP gas dealer for assistance.

- Do not release liquid propane (LP) gas into the atmosphere. This is a hazardous practice.

- To remove gas from LP cylinder, contact an LP dealer or call a local fire department for assistance. Check the telephone directory under "Gas Companies" for nearest certified LP dealers.

LP Cylinder Exchange

- Many retailers that sell grills offer you the option of replacing your empty LP cylinder through an exchange service. Use only those reputable exchange companies that inspect, precision fill, test and certify their cylinders. **Exchange your cylinder only for an OPD safety feature-equipped cylinder as described in the "LP Cylinder" section of this manual.**
- Always keep new and exchanged LP cylinders in upright position during use, transit or storage.
- **Leak test new and exchanged LP cylinders BEFORE connecting to grill.**

LP Cylinder Leak Test

For your safety

- Leak test must be repeated each time LP cylinder is exchanged or refilled.
 - Do not smoke during leak test.
 - Do not use an open flame to check for gas leaks.
 - Grill must be leak tested outdoors in a well-ventilated area, away from ignition sources such as gas fired or electrical appliances. During leak test, keep grill away from open flames or sparks.
 - Use a clean paintbrush and a 50/50 mild soap and water solution. Brush soapy solution onto areas indicated by arrows in figure below.
- ▲ **Do not use household cleaning agents.** Damage to gas train components can result.

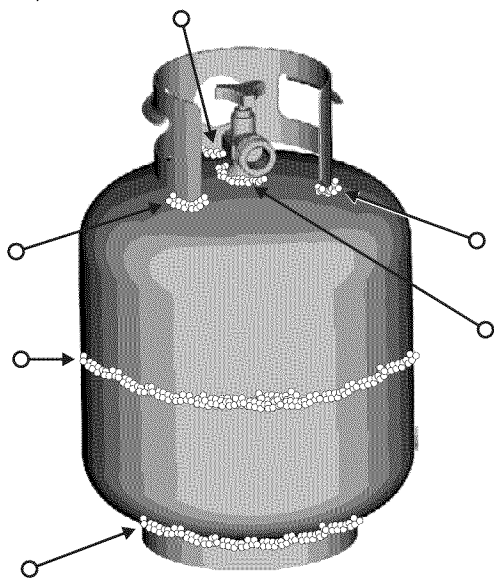

| | | |
|---|----------------|--|
| | WARNING | |
| If "growing" bubbles appear do not use or move the LP cylinder. Contact an LP gas supplier or your fire department! | | |

Connecting Regulator to the LP Cylinder

1. LP cylinder must be properly secured onto grill. (Refer to assembly section.)
2. Turn all control knobs to the OFF position.
3. Turn LP cylinder OFF by turning hand-wheel clockwise to a full stop.
4. Remove the protective cap from LP cylinder valve. Always use cap and strap supplied with valve.

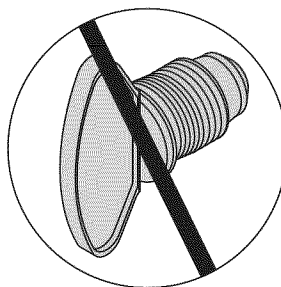
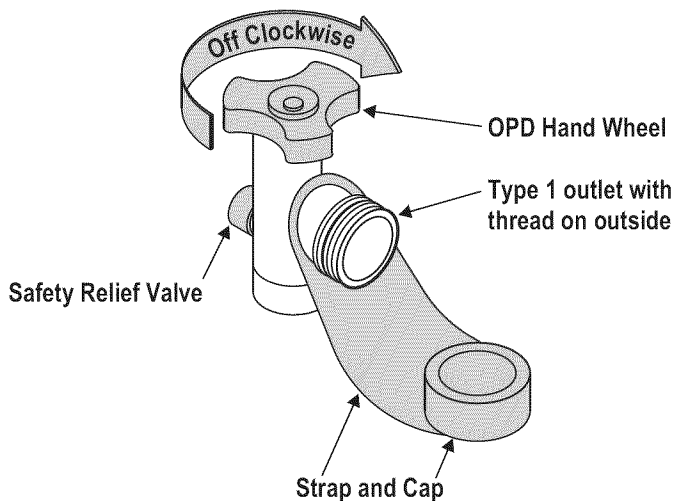

Do not use a POL transport plug (plastic part with external threads)! It will defeat the safety feature of the valve.

5. Hold regulator and insert nipple into LP cylinder valve. Hand-tighten the coupling nut, holding regulator in a straight line with LP cylinder valve so as not to cross-thread the connection.

Nipple has to be centered into the LP cylinder valve.

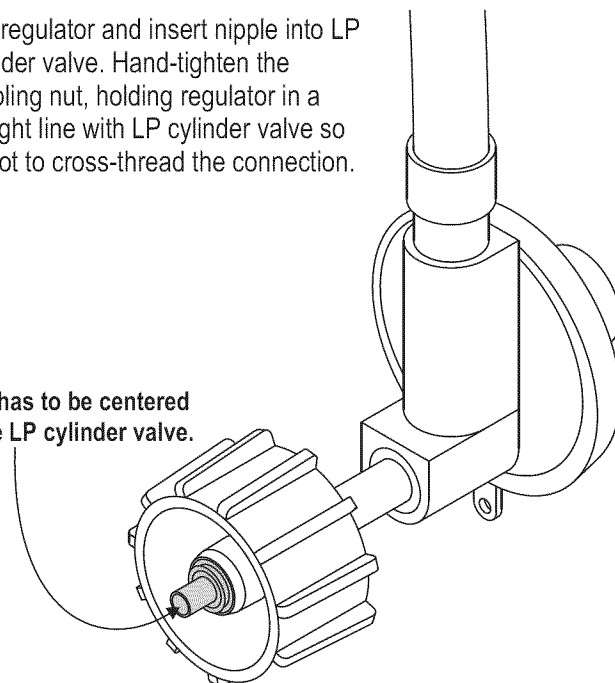

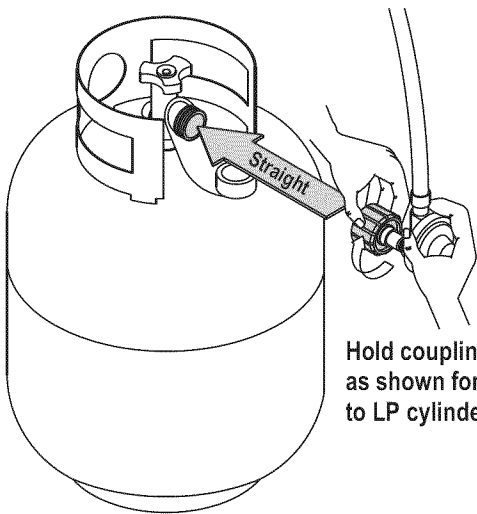

Hold coupling nut and regulator as shown for proper connection to LP cylinder valve.

6. Turn the coupling nut clockwise and tighten to a full stop. The regulator will seal on the back-check feature in the LP cylinder valve, resulting in some resistance. **An additional one-half to three-quarters turn is required to complete the connection. Tighten by hand only – do not use tools.**

NOTE:

If you cannot complete the connection, disconnect regulator and repeat steps 5 and 6. If you are still unable to complete the connection, **do not use this regulator!**

| | | |
|--|---------------|--|
| | DANGER | |
| <ul style="list-style-type: none"> Do not insert any tool or foreign object into the valve outlet or safety relief valve. You may damage the valve and cause a leak. Leaking propane may result in explosion, fire, severe personal injury, or death. | | |

| | | |
|---|----------------|--|
| | WARNING | |
| <ul style="list-style-type: none"> Outdoor gas appliance is not intended to be installed in or on a boat. Outdoor gas appliance is not intended to be installed in or on an RV. Never attempt to attach this grill to the self-contained LP gas system of a camper trailer or motor home. Do not use grill until leak-tested. If a leak is detected at any time, STOP and call the fire department. If you cannot stop a gas leak, <i>immediately</i> close LP cylinder valve and call LP gas supplier or your fire department! | | |

Leak Testing Valves, Hose and Regulator

1. Turn all grill control knobs to OFF.
2. Be sure regulator is tightly connected to LP cylinder.
3. Completely open LP cylinder valve by turning hand wheel counterclockwise. If you hear a *rushing sound*, turn gas off immediately. There is a major leak at the connection. **Correct before proceeding.**
4. Brush soapy solution onto areas circled below.

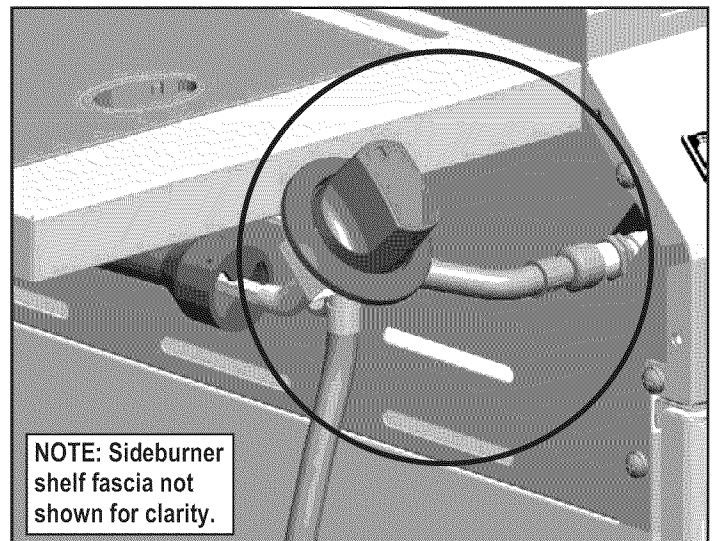
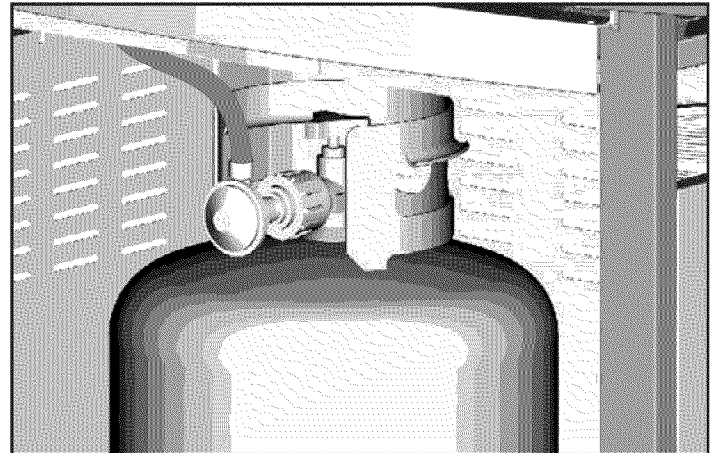

NOTE: Sideburner shelf fascia not shown for clarity.

5. If “growing” bubbles appear, there is a leak. Close LP cylinder valve immediately and retighten connections. **If leaks cannot be stopped do not try to repair.** Call for replacement parts.
6. Always close LP cylinder valve after performing leak test by turning hand wheel clockwise.





WARNING



For Safe Use of Your Grill and to Avoid Serious Injury:

- Do not let children operate or play near grill.
- Keep grill area clear and free from materials that burn.
- Do not block holes in sides or back of grill.
- Check burner flames regularly.
- Use grill only in well-ventilated space. NEVER use in enclosed space such as carport, garage, porch, covered patio, or under an overhead structure of any kind.
- Do not use charcoal or ceramic briquets in a gas grill. (*Unless briquets are supplied with your grill.*)
- **Use grill at least 3 ft. from any wall or surface.** Maintain 10 ft. clearance to objects that can catch fire or sources of ignition such as pilot lights on water heaters, live electrical appliances, etc.

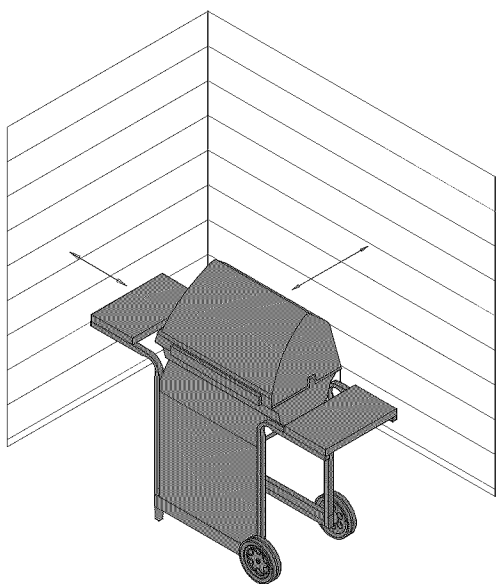

• Apartment Dwellers:

Check with management to learn the requirements and fire codes for using an LP gas grill in your apartment complex. If allowed, use outside on the ground floor with a three (3) foot clearance from walls or rails. Do not use on or under balconies.

- **NEVER attempt to light burner with lid closed. A buildup of non-ignited gas inside a closed grill is hazardous.**
- **Never operate grill with LP cylinder out of correct position specified in assembly instructions.**
- **Always close LP cylinder valve and remove coupling nut before moving LP cylinder from specified operation position.**

Safety Tips

- ▲ Before opening LP cylinder valve, check the coupling nut for tightness.
- ▲ When grill is not in use, turn off all control knobs and LP cylinder valve.
- ▲ Never move grill while in operation or still hot.
- ▲ Use long-handled barbecue utensils and oven mitts to avoid burns and splatters.
- ▲ Maximum load for sideburner and side shelf is 10 lbs.
- ▲ The grease tray **must** be inserted into grill and emptied after each use. Do not remove grease tray until grill has completely cooled.
- ▲ Clean grill often, preferably after each cookout. If a bristle brush is used to clean any of the grill cooking surfaces, ensure no loose bristles remain on cooking surfaces prior to grilling. It is not recommended to clean cooking surfaces while grill is hot.
- ▲ If you notice grease or other hot material dripping from grill onto valve, hose or regulator, turn off gas supply at once. Determine the cause, correct it, then clean and inspect valve, hose and regulator before continuing. Perform a leak test.
- ▲ Keep ventilation openings in cylinder enclosure (grill cart) free and clear of debris.
- ▲ Do not store objects or materials inside the grill cart enclosure that would block the flow of combustion air to the underside of either the control panel or the firebox bowl.
- ▲ The regulator may make a humming or whistling noise during operation. This will not affect safety or use of grill.
- ▲ If you have a grill problem see the "Troubleshooting Section".
- ▲ If the regulator frosts, turn off grill and LP cylinder valve immediately. This indicates a problem with the cylinder and it should not be used on any product. Return to supplier!





CAUTION



- **Putting out grease fires by closing the lid is not possible. Grills are well ventilated for safety reasons.**
- **Do not use water on a grease fire. Personal injury may result. If a grease fire develops, turn knobs and LP cylinder off.**
- **Do not leave grill unattended while preheating or burning off food residue on HI. If grill has not been regularly cleaned, a grease fire can occur that may damage the product.**

Ignitor Lighting

- ▲ **Do not lean over grill while lighting.**

1. Turn **OFF** gas burner control valves.
2. Turn **ON** gas source or tank.
3. **Open lid during lighting.**
4. To ignite, turn **IGNITION BURNER** knob to  **HIGH**.
5. Push and hold **ELECTRONIC IGNITION** button.
6. If ignition does NOT occur in 5 seconds, turn the burner controls **OFF**, wait 5 minutes and repeat the lighting procedure.
7. Ignite other burners by turning knob to .

If ignitor does not work, follow match lighting instructions. After Lighting: Turn knobs to HIGH position for warm-up.

Lighting instructions continued on next page.



WARNING



Turn controls and gas source or tank OFF when not in use.



CAUTION



If ignition does NOT occur in 5 seconds, turn the burner controls OFF, wait 5 minutes and repeat the lighting procedure. If the burner does not ignite with the valve open, gas will continue to flow out of the burner and could accidentally ignite with risk of injury.

Match-Lighting

▲ Do not lean over grill while lighting.

1. **Open lid.** Turn on gas at LP cylinder.
2. Place lit match into match holder (hanging from cart side panel), light burner on right or left side of grill.
3. Push in and turn far right or far left burner knob to HIGH. Be sure burner lights and stays lit.
4. Light adjacent burners in sequence by pushing knobs in and turning to HIGH.

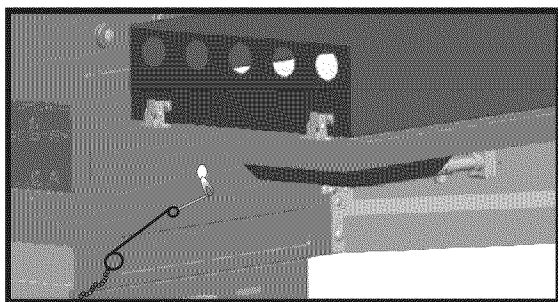

Sideburner Ignitor Lighting

▲ Do not lean over grill while lighting.

1. Turn OFF gas burner control valves.
2. Turn ON gas source or tank.
3. To ignite **SIDEBURNER**, open sideburner cover.
4. Turn side burner knob to 🔥. Push and hold ELECTRONIC IGNITION button.
5. If sideburner does NOT light, turn knob to OFF, wait 5 minutes, then repeat lighting procedure.

Sideburner Match Lighting

1. **Open sideburner lid.** Turn on gas at LP cylinder.
2. Place lit match near burner.
3. Turn sideburner knob to 🔥. Be sure burner lights and stays lit.

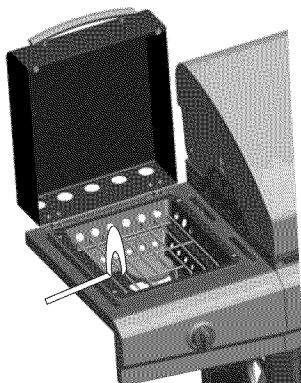

Burner Flame Check

- Remove cooking grates and flame tamers. Light burners, rotate knobs from HIGH to LOW. You should see a smaller flame in LOW position than seen on HIGH. Perform burner flame check on sideburner, also. Always check flame prior to each use. If only low flame is seen refer to "Sudden drop or low flame" in the *Troubleshooting Section*.

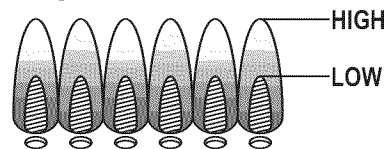

Turning Grill Off

- Turn all knobs to **OFF** position. Turn LP cylinder off by turning hand-wheel clockwise to a full stop.

Ignitor Check

- **Turn gas off at LP cylinder.** Press and hold electronic ignitor button. "Click" should be heard and spark seen each time between collector box or burner and electrode. See "*Troubleshooting*" if no click or spark.

Valve Check

- **Important: Make sure gas is off at LP cylinder before checking valves.** Knobs lock in **OFF** position. To check valves, first push in knobs and release, knobs should spring back. If knobs do not spring back, replace valve assembly before using grill. Turn knobs to **LOW** position then turn back to **OFF** position. Valves should turn smoothly.

Hose Check

- Before each use, check to see if hoses are cut or worn. Replace damaged hoses before using grill. Use only valve/hose/regulator specified by manufacturer.

General Grill Cleaning

- Do not mistake brown or black accumulation of grease and smoke for paint. Interiors of gas grills are not painted at the factory (**and should never be painted**). Apply a strong solution of detergent and water or use a grill cleaner with scrub brush on insides of grill lid and bottom. Rinse and allow to completely air dry. **Do not apply a caustic grill/oven cleaner to painted surfaces.**
- **Plastic parts:** Wash with warm soapy water and wipe dry.
 - ▲ Do not use citrisol, abrasive cleaners, degreasers or a concentrated grill cleaner on plastic parts. Damage to and failure of parts can result.
- **Porcelain surfaces:** Because of glass-like composition, most residue can be wiped away with baking soda/water solution or specially formulated cleaner. Use nonabrasive scouring powder for stubborn stains.
- **Painted surfaces:** Wash with mild detergent or nonabrasive cleaner and warm soapy water. Wipe dry with a soft nonabrasive cloth.
- **Stainless steel surfaces:** To maintain your grill's high quality appearance, wash with mild detergent and warm soapy water and wipe dry with a soft cloth after each use. Baked-on grease deposits may require the use of an abrasive plastic cleaning pad. Use only in direction of brushed finish to avoid damage. Do not use abrasive pad on areas with graphics.
- **Cooking surfaces:** If a bristle brush is used to clean any of the grill cooking surfaces, ensure no loose bristles remain on cooking surfaces prior to grilling. It is not recommended to clean cooking surfaces while grill is hot.



CAUTION



SPIDER ALERT!

SPIDER AND WEBS
INSIDE BURNER TUBE

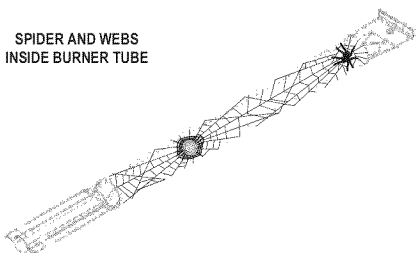

If you notice that your grill is getting hard to light or that the flame isn't as strong as it should be, take the time to check and clean the venturi's.

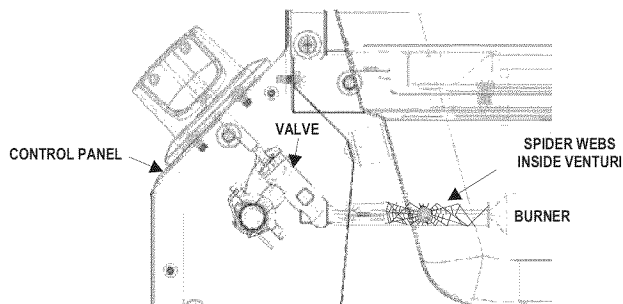

In some areas of the country, spiders or small insects have been known to create "flashback" problems. The spiders spin webs, build nests and lay eggs in the grill's venturi tube(s) obstructing the flow of gas to the burner. The backed-up gas can ignite in the venturi behind the control panel. This is known as a flashback and it can damage your grill and even cause injury.

To prevent flashbacks and ensure good performance the burner and venturi assembly should be removed from the grill and cleaned before use whenever the grill has been idle for an extended period.

Cleaning the Burner Assembly

Follow these instructions to clean and/or replace parts of burner assembly or if you have trouble igniting grill.

1. Turn gas off at control knobs and LP cylinder.
2. Remove cooking grates and flame tamers.
3. Remove screws and carryover tubes from rear of burners.
4. Remove screw and washers to disengage burner from bracket on firebox.
5. Remove screws to detach electrode from burner. Electrode should remain in firebox.
6. Carefully lift each burner up and away from valve openings.

We suggest three ways to clean the burner tubes. Use the one easiest for you.

- (A) Bend a stiff wire (a light weight coat hanger works well) into a small hook. Run the hook through each burner tube several times.



- (B) Use a narrow bottle brush with a flexible handle (do not use a brass wire brush), run the brush through each burner tube several times.

- (C) **Wear eye protection:** Use an air hose to force air into the burner tube and out the burner ports. Check each port to make sure air comes out each hole.

7. Wire brush entire outer surface of burner to remove food residue and dirt.
8. Clean any blocked ports with a stiff wire such as an open paper clip.
9. Check burner for damage, due to normal wear and corrosion some holes may become enlarged. If any large cracks or holes are found replace burner.

VERY IMPORTANT: Burner tubes must reengage valve openings. See illustrations at right.

10. Attach electrode to burner.
11. Carefully replace burners.
12. Attach burners to brackets on firebox.
13. Reposition carryover tubes and attach to burners. Replace flame tamers and cooking grates.

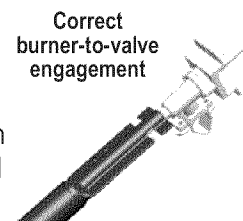

Storing Your Grill

- Clean cooking grates.
- Store in dry location.
- When LP cylinder is connected to grill, store outdoors in a well-ventilated space and out of reach of children.
- Cover grill if stored outdoors. Choose from a variety of grill covers offered by manufacturer.
- Store grill indoors ONLY if LP cylinder is turned off and disconnected, removed from grill and stored outdoors.
- When removing grill from storage, follow "Cleaning the Burner Assembly" instructions before starting grill.

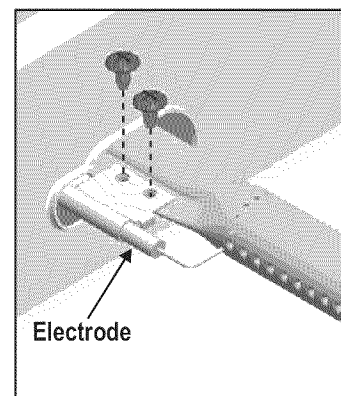
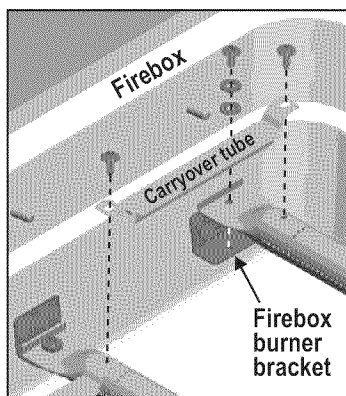

GRILLING GUIDE – Getting Started

First Time Use

Read your Assembly Manual and ensure the grill is put together properly. Remove all Point-of-Purchase advertising material from all grill surfaces before first use. We recommend operating your grill on its highest setting for 15-20 minutes prior to your first use. This aids in removing the oils used during manufacturing.

Lava Rock / Briquettes

This gas grill has been designed, engineered, and tested to be used with flame tamers or heat distribution plates to provide more even heating, improve the cleaning process, and reduce flare-ups. The addition of after market lava rocks, charcoal, or briquettes of any type will cause poor combustion and increase the likelihood of a grease fire, and is not recommended. Using briquettes, lava rock, or charcoal in this grill will void your warranty. For extra smoke flavor, we recommend using a smoker box with wood chips.



Temperature

The temperature gauge in the hood of your new grill measures air temperature. The air temperature inside your grill will never be as hot as the temperature at the cooking surface.

Note: Since 1995, all regulators (the part that attaches to the gas tank to regulate the flow of gas) have included a safety feature that restricts gas flow in the event of a gas leak. You can inadvertently activate this safety feature without having a gas leak. This typically occurs when you turn on the gas using the grill control knob before you turn on the LP tank valve. If the gas regulator safety feature activates, the grill will only reach temperatures between 250°F and 300°F even with all burners on the high setting.

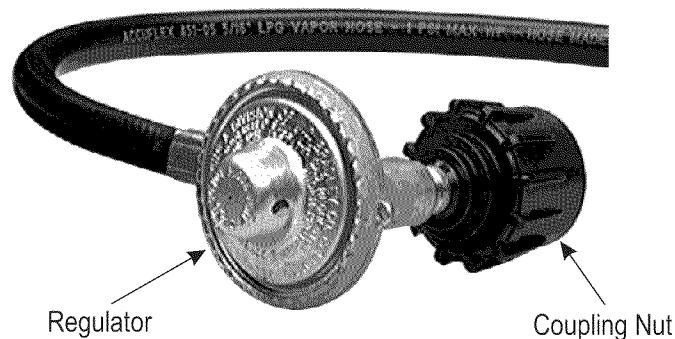

If your grill is not getting hotter than 250°F to 300°F these steps should be taken first to reset the gas regulator safety device:

1. Open the grill lid.
2. Turn off all knobs on the control panel in front.
3. Turn off the tank knob.
4. Disconnect the regulator from the LP tank.
5. Wait 30 seconds.
6. Reconnect the regulator to the LP tank.
7. Slowly open the LP tank knob all the way. Do not put excessive force on the valve at the full open position to avoid damaging the valve.
8. Turn on the appropriate control knob and light the grill per the instructions on the control panel.

An illustration of this process is included in this Product Guide. See Troubleshooting section for additional information.

Pre-Heating Your Grill

Just like your home oven, your grill should be pre-heated to provide optimum performance. Pre-heat the grill on high for 10-15 minutes – longer if weather conditions require. Please refer to the lighting instructions inside the Product Guide if you have questions about how to light your grill. A match-light chain and hole is provided for your convenience.

GRILLING GUIDE – Grilling 101

Outdoor grilling is really quite simple. You'll succeed with burgers, dogs, or steaks usually on your very first try. With experience, you will learn how to work with your grill, creating more imaginative meals all the time. This knowledge makes up the art of grilling. Before you start grilling, organize your food according to cooking technique and required cooking time, and optimize the use of your grilling area.

Direct Cooking

Direct cooking involves grilling your meat directly over high heat. It is perfect for searing steaks, chops, and other smaller pieces of meat and vegetables that quickly make their way to the table.

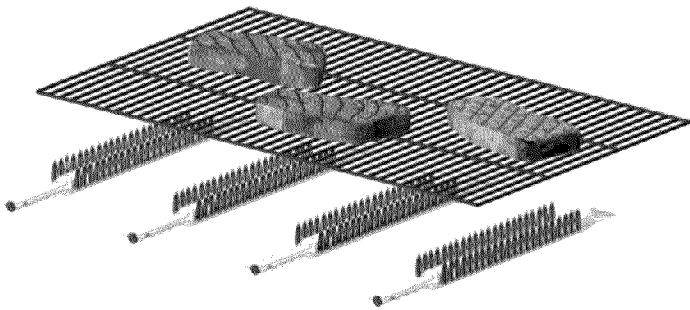

Indirect Cooking

Indirect cooking utilizes select burners to circulate heat throughout the grill, without direct contact between the meat and the flame. The meat is placed over the burner that is 'off'. This method is generally used to slow cook large cuts of meat and poultry. A pan can be placed underneath the meat to catch grease and food drippings, and helps minimize clean-up.

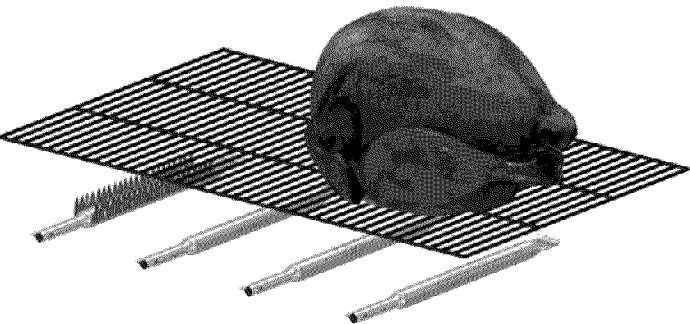
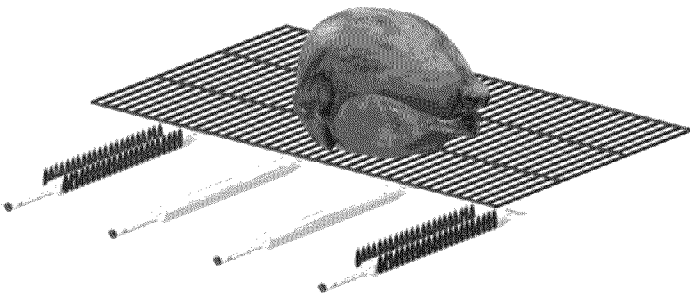

Rotisserie Cooking

Rotisserie cooking is best for 'round' meat, such as large roasts, whole poultry, and pork. It generally requires an accessory motor and spit rod that allows the meat to be turned at a constant speed. Rotisserie cooking is best done in front of a special rotisserie burner, or utilizing an indirect cooking burner arrangement. A pan can be placed underneath the meat to catch grease and food drippings, and helps minimize clean-up.

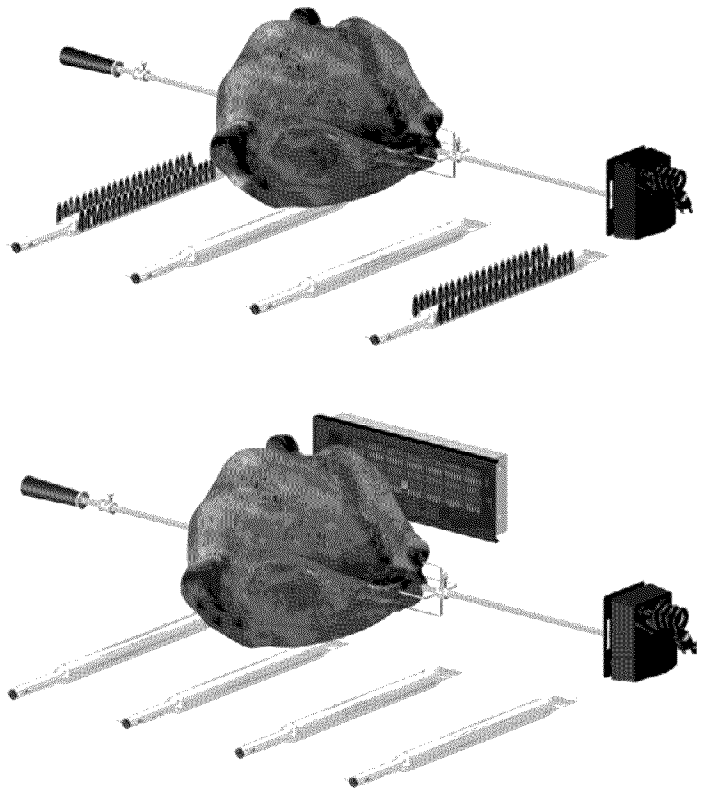

Food Safety

Food safety is a very important part of enjoying the outdoor cooking experience. To keep food safe from harmful bacteria, follow these four basic steps:

Clean: Wash hands, utensils, and surfaces with hot soapy water before and after handling raw meat.

Separate: Separate raw meats from ready-to-eat foods to avoid cross contamination. Use a clean platter and utensils when removing cooked foods.

Cook: Cook meat and poultry thoroughly to kill bacteria. Use a thermometer to ensure proper internal food temperatures.

Chill: Refrigerate prepared foods and leftovers promptly.

GRILLING GUIDE – Tips & Tricks

Cooking on your new grill is a hands-on experience, and it is recommended to remain outside with your grill while cooking. Grilling can be affected by many external conditions. In cold weather, you will need more heat to reach an ideal cooking temperature, and grilling may take longer. The meat's internal temperature and thickness can also affect cooking times. Cold and thicker meats will take longer to cook.

Internal Meat Temperatures

Meat cooked on a grill often browns very fast on the outside. Therefore, use a meat thermometer to ensure it has reached safe internal temperatures.

| USDA Recommended Safe Minimum Internal Temperatures | |
|---|--------|
| Beef, Veal, Lamb, Steaks, & Roasts | 145° F |
| Fish | 145° F |
| Pork | 160° F |
| Beef, Veal, Lamb Ground | 160° F |
| Egg Dishes | 160° F |
| Turkey, Chicken & Duck Whole, Pieces & Ground | 165° F |

Please refer to the USDA for complete, up-to-date information. Our internal temperature chart is based on USDA standards for meat doneness. Check it out at www.isitdoneyet.gov

Sauces

Sauces containing sugars and fats can cause flare-ups, and your food may burn. In general, apply these sauces during the final 10 minutes of cooking. Keep in mind, use of excessive sauces or glazes will also require extra cleaning afterwards.

Marinades and Rubs

To enhance the flavor of grilled foods, a liquid marinade or dry rub can be used prior to cooking. Meat can be either soaked or injected with liquid marinade up to 24 hours prior to grilling. Dry rubs can be applied directly to the meat immediately before grilling.



Wood Chips

For extra smoke flavor when grilling, try adding wood chips. Soak the chips in water for approximately 30 minutes before adding to a smoke box or pan. Place smoke box or pan on top of the cooking grate above the flame. Turn grill on high until the wood starts to smoke. Reduce heat to desired temperature for cooking, and place food on cooking grate as desired. Close lid to retain more smoke. Hardwood varieties that work particularly well with grilled foods include Alder, Apple, Cherry, Grapevines, Hickory, Mesquite, Oak, Rosemary and Sassafras.



Skewers

Metal skewers should be flat, with long handles. Round skewers allow food to roll when turned, so it may not cook as evenly. Use metal skewers when cooking meat kabobs. Wooden skewers should be soaked in water for an hour before use, and are best used for quick cooking foods such as vegetables and fruits.



Utensils

Use tongs or a spatula to handle the food instead of a fork, and don't turn the food too often. Piercing the food with a fork will release juices that you want in the meat, and may cause flare-ups.

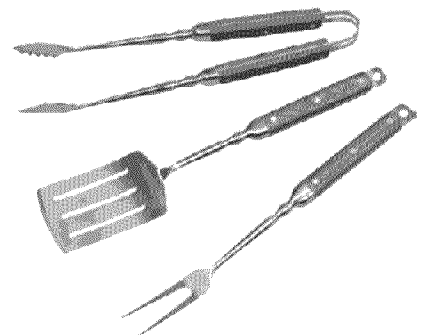

GRILLING GUIDE – Cleaning Your Grill

Why Clean?

We've all heard the saying, 'an ounce of prevention is worth a pound of cure.' This is great advice when it comes to keeping your grill clean.

Routine Care

Periodic cleaning of this grill is necessary, as grill fires can occur when grease and food debris collect in the bottom of the grill. After each use, remove any remaining food particles from the cooking grate and inside of the grill using a grill brush. Do this after the grill has cooled down, yet is still warm. It is much easier to clean food particles while warmth is still present, than after the food particles have completely cooled and hardened. This grill is not designed to be 'burned off' by closing the lid and turning the burners on High for an extended time. The excessive heat generated can cause leftover grease to catch fire, and can cause permanent damage to your grill.



General Cleaning

Plastic parts: Wash with warm soapy water and wipe dry. Do not use abrasive cleaners, degreasers or a concentrated grill cleaner on plastic parts. Damage to and failure of parts can result.

Porcelain surfaces: Because of glass-like composition, most residue can be wiped away with baking soda/water solution or glass cleaner. Use non-abrasive scouring powder for stubborn stains.

Painted surfaces: Wash with mild detergent or non-abrasive cleaner and warm water. Wipe dry with a soft non-abrasive cloth.

Stainless steel surfaces: Stainless steel can rust under certain conditions. This can be caused by environmental conditions such as chlorine or salt water, or improper cleaning tools such as wire or steel wool. It can also discolor due to heat, chemicals, or grease build-up. To maintain your grill's high quality appearance, wash with mild detergent and warm water, or use a stainless steel grill cleaner. Baked-on grease deposits may require the use of an abrasive plastic cleaning pad. Use only in direction of brushed finish to avoid damage. Do not use abrasive pad on areas with graphics.

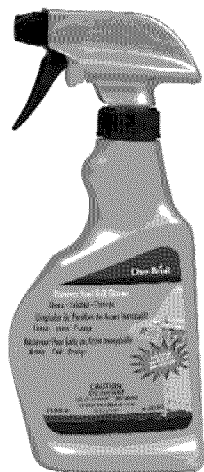

Cooking surfaces: If a bristle brush is used to clean any of the grill cooking surfaces, ensure no loose bristles remain on cooking surfaces prior to grilling. It is not recommended to clean cooking surfaces while grill is hot.

Storing Your Grill

- Clean cooking grates.
- Store grill in dry location.
- When LP cylinder is connected to grill, store outdoors in a well ventilated space and out of reach of children.
- Cover grill if stored outdoors. Choose from a variety of grill covers offered by manufacturer.
- Store grill indoors ONLY if LP cylinder is turned off, disconnected, and removed from grill. Never store LP cylinder indoors.
- When removing grill from storage, follow the 'Cleaning the Burner Assembly' instructions in the Use and Care section of the Product Guide.



Critters

Spiders like to make their homes in the venturi tubes of grills. These must be inspected and cleaned regularly to ensure there are no blockages. Refer to the Use and Care portion of this Product Guide for complete information.

LIMITED WARRANTY

This warranty only applies to units purchased from an authorized retailer. Manufacturer warrants to the **original consumer-purchaser** only that this product shall be free from defects in workmanship and materials after correct assembly and under normal and reasonable home use for the periods indicated below beginning on the date of purchase*. The manufacturer reserves the right to require that defective parts be returned, postage and or freight pre-paid by the consumer for review and examination.

| <u>SCOPE OF COVERAGE</u> | <u>PERIOD OF COVERAGE</u> | <u>TYPE OF FAILURE COVERAGE</u> |
|--------------------------|--------------------------------|--|
| Burner | 2 years from date of purchase* | PERFORATION, MANUFACTURING, AND MATERIAL DEFECTS ONLY |
| All Other Parts | 1 year from date of purchase* | |

*Note: A dated sales receipt WILL be required for warranty service.

The original consumer-purchaser will be responsible for all shipping charges for parts replaced under the terms of this limited warranty.

This limited warranty is applicable in the United States and Canada only, is only available to the original owner of the product and is not transferable. Manufacturer requires proof of your date of purchase. Therefore, you should retain your sales slip or invoice. Registering your product is not a substitute for proof of purchase and the manufacturer is not responsible for or required to retain proof of purchase records.

This limited warranty applies to the functionality of the product **ONLY** and does not cover cosmetic issues such as scratches, dents, corruptions or discoloring by heat, abrasive and chemical cleaners or any tools used in the assembly or installation of the appliance, surface rust, or the discoloration of stainless steel surfaces. **RUST is not considered a manufacturing or materials defect.**

This limited warranty will not reimburse you for the cost of any inconvenience, food, personal injury or property damage.

ITEMS MANUFACTURER WILL NOT PAY FOR:

1. Shipping cost, standard or expedited, for warranty and replacement parts
2. Service calls to your home.
3. Repairs when your product is used for other than normal, single-family household or residential use.
4. Damage, failures, or operating difficulties resulting from accident, alteration, careless handling, misuse, abuse, fire, flood, acts of God, improper installation or maintenance, installation not in accordance with electrical or plumbing codes, or use of products not approved by the manufacturer.
5. Any food loss due to product failures or operating difficulties.
6. Replacement parts or repair labor costs for units operated outside the United States or Canada.
7. Pickup and delivery of your product.
8. Repairs to parts or systems resulting from unauthorized modifications made to the product.
9. The removal and/or reinstallation of your product.

DISCLAIMER OF IMPLIED WARRANTIES and LIMITATION OF REMEDIES

Repair or replacement of defective parts is your exclusive remedy under the terms of this limited warranty. Manufacturer will not be responsible for any consequential or incidental damages arising from the breach of either this limited warranty or any applicable implied warranty, or for failure or damage resulting from acts of God, improper care and maintenance, grease fire, accident, alteration, replacement of parts by anyone other than Manufacturer, misuse, transportation, commercial use, abuse, hostile environments (inclement weather, acts of nature, animal tampering), improper installation or installation not in accordance with local codes or printed manufacturer instructions.

THIS LIMITED WARRANTY IS THE SOLE EXPRESS WARRANTY GIVEN BY THE MANUFACTURER. NO PRODUCT PERFORMANCE SPECIFICATION OR DESCRIPTION WHEREVER APPEARING IS WARRANTED BY MANUFACTURER EXCEPT TO THE EXTENT SET FORTH IN THIS LIMITED WARRANTY. ANY IMPLIED WARRANTY PROTECTION ARISING UNDER THE LAWS OF ANY STATE, INCLUDING IMPLIED WARRANTY OF MERCHANTABILITY OR FITNESS FOR A PARTICULAR PURPOSE OR USE, IS HEREBY LIMITED IN DURATION TO THE DURATION OF THIS LIMITED WARRANTY.

Neither dealers nor the retail establishment selling this product has any authority to make any additional warranties or to promise remedies in addition to or inconsistent with those stated above. Manufacturer's **maximum liability**, in any event, shall not exceed the purchase price of the product paid by the original consumer.

NOTE: Some states do not allow an exclusion or limitation of incidental or consequential damages, so some of the above limitations or exclusions may not apply to you. This limited warranty gives you specific legal rights as set forth herein. You may also have other rights which vary from state to state. In the state of California only, if refinishing or replacement of the product is not commercially practicable, the retailer selling this product or the Manufacturer will refund the purchase price paid for the product, less the amount directly attributable to use by the original consumer-purchaser prior to discovery of the nonconformity. In addition, in the state of California only, you may take the product to the retail establishment selling this product in order to obtain performance under this limited warranty.

If you wish to obtain performance of any obligation under this limited warranty, you should write to:

**Consumer Relations
P. O. Box 1240
Columbus, GA 31902-1240**

Consumer returns will not be accepted unless a valid Return Authorization is first acquired. Authorized returns are clearly marked on the outside of the package with an RA number and the package is shipped freight/postage pre-paid. Consumer returns that do not meet these standards will be refused.

PARTS LIST

| Key | Qty | Description |
|-----|-----|-----------------------------------|
| A | 1 | FIREBOX |
| B | 4 | TUBE BURNER |
| C | 1 | ELECTRODE, MAIN BURNER |
| D | 3 | CARRY OVER TUBE |
| E | 1 | CONTROL PANEL, MAIN |
| F | 1 | ELECTRONIC MODULE, W/BUTTON |
| G | 1 | BUTTON, F/ ELECTRONIC MODULE |
| H | 1 | VALVE/ HOSE/ REGULATOR |
| I | 5 | BEZEL F/ KNOB |
| J | 5 | CONTROL KNOB |
| K | 1 | GRILL LID |
| L | 1 | LOGO PLATE |
| M | 1 | TEMPERATURE GAUGE |
| N | 2 | LID BUMPER, RECTANGLE |
| O | 1 | GRILL LID HANDLE |
| P | 1 | TOP LID HARDWARE |
| Q | 4 | HEAT TENT |
| R | 3 | COOKING GRATE |
| S | 1 | SWING AWAY GRID |
| T | 1 | LEFT SIDE SHELF |
| U | 1 | DRIP PAN F/ SIDEBURNER |
| V | 1 | SIDEBURNER LID |
| W | 1 | CONTROL PANEL F/ LEFT SHELF |
| X | 1 | SIDEBURNER GRATE |
| Y | 1 | SIDEBURNER |
| Z | 1 | ELECTRODE, F/ SB |
| AA | 1 | RIGHT SIDE SHELF |
| BB | 1 | CONTROL PANEL F/ RIGHT SIDE SHELF |
| CC | 1 | CART, RIGHT SIDE |
| DD | 1 | MATCH HOLDER |
| EE | 1 | CART, LEFT SIDE |
| FF | 1 | FRONT PANEL |
| GG | 1 | BOTTOM SHELF |
| HH | 1 | AXLE ROD |
| II | 2 | WHEEL |

| Key | Qty | Description |
|-----|-----|--------------------------|
| JJ | 1 | GREASE CUP |
| KK | 1 | CLIP, F/ GREASE CUP |
| LL | 1 | TANK EXCLUSION |
| MM | 2 | LEG EXTENDER |
| NN | 1 | WING SCREW F/ TANK |
| OO | 2 | LID BUMPER, ROUND |
| PP | 1 | WIRE, F/ SIDEBURNER |
| QQ | 1 | HEAT SHIELD F/ EI MODULE |

NOT Pictured

| | | |
|-----|---|--------------------------|
| ... | 1 | VENTURI CLIP F/ SB |
| ... | 1 | HARDWARE PACK |
| ... | 1 | ASSEMBLY MANUAL, ENGLISH |
| ... | 1 | ASSEMBLY MANUAL, SPANISH |

NOTE: Some grill parts shown in the assembly steps may differ slightly in appearance from those on your particular grill model. However, the method of assembly remains the same.

PARTS DIAGRAM

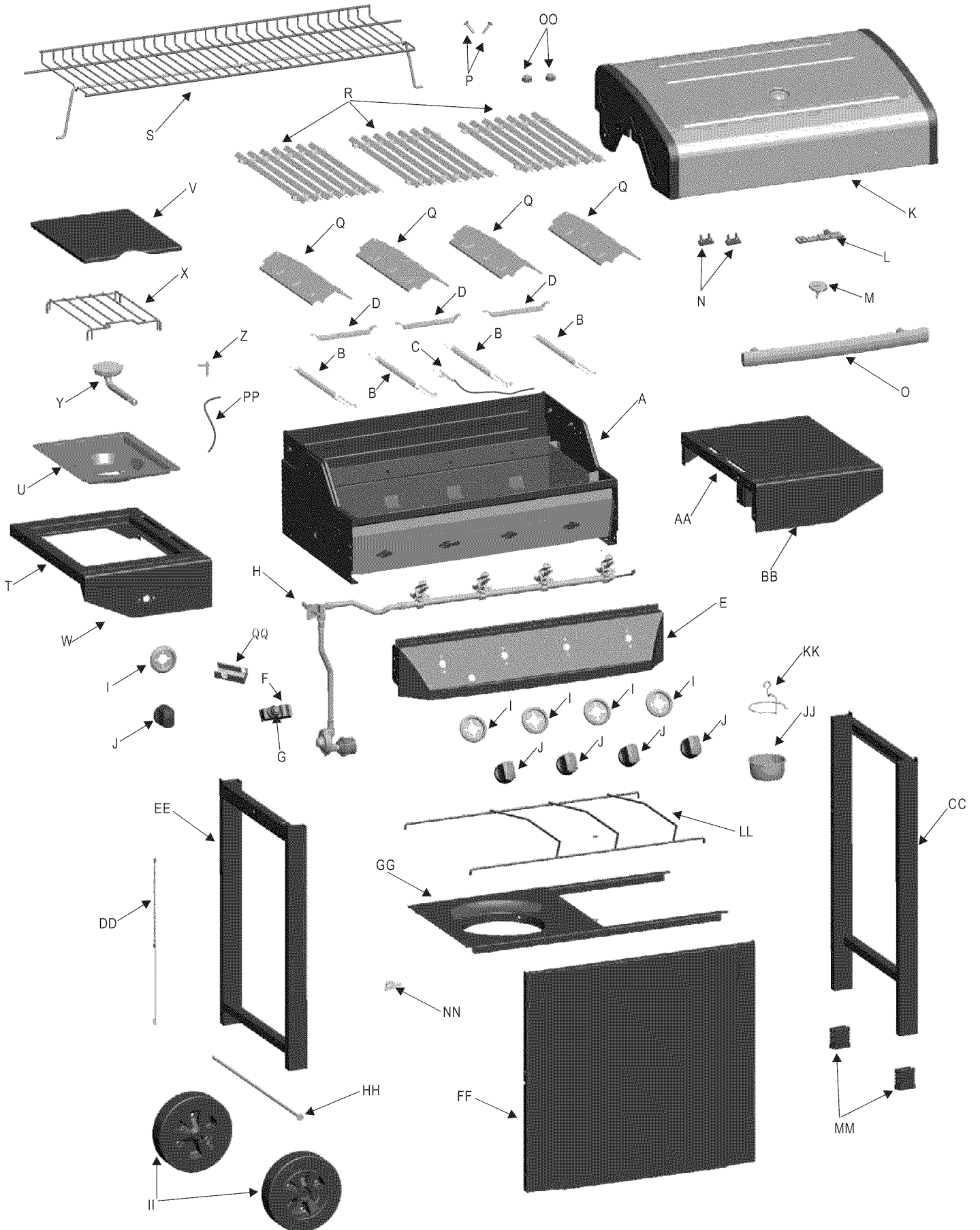

ASSEMBLY

1

- Place legs as shown . Left leg assembly has large holes on ends of legs. Hook tank exclusion wire into right and left leg assemblies

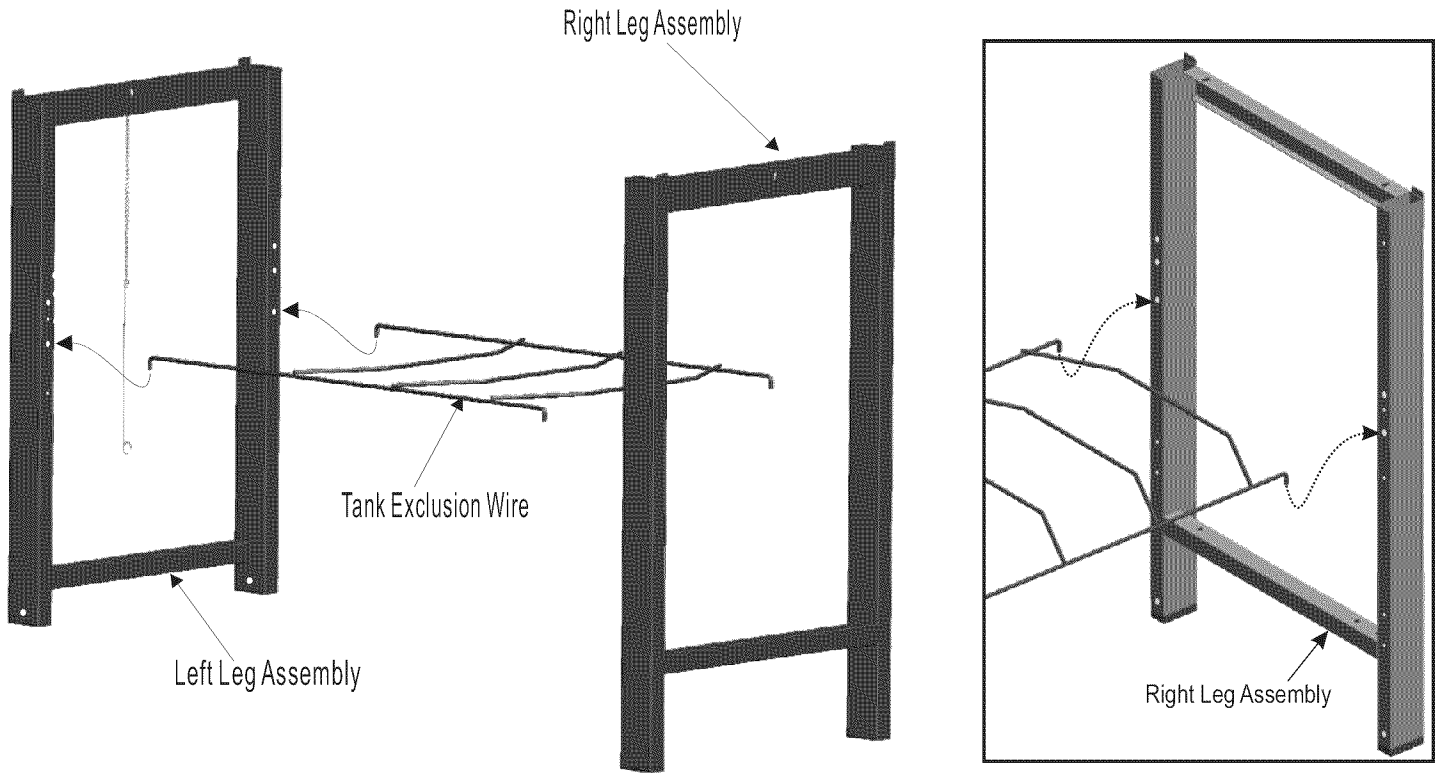

2

- Place bottom shelf with cut out hole for LP tank next to legs with axle holes.
- Attach to right and left leg assemblies with 1/4"-20x1-1/2" screws and 1/4"-20 flange nuts.

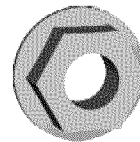
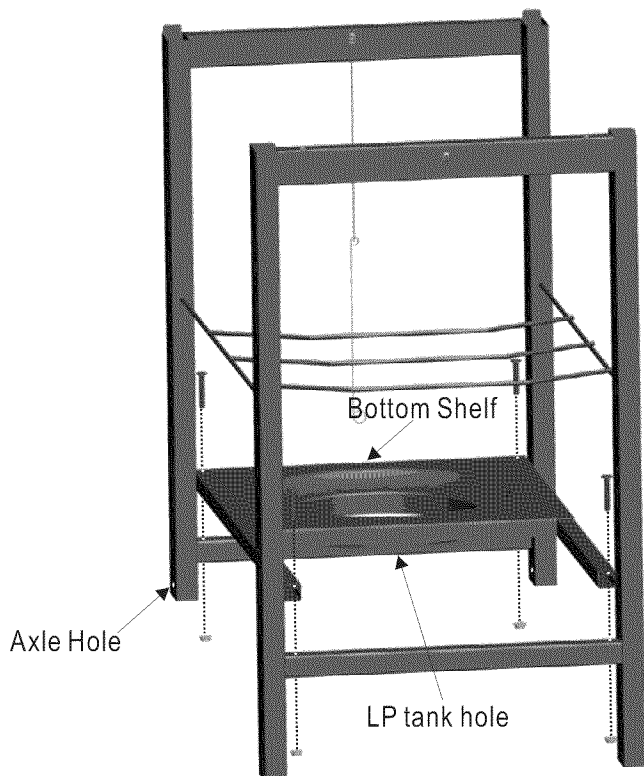

Qty: 4
1/4"-20
Flange Nut

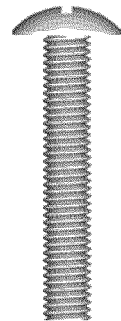

Qty: 4
1/4"-20x1-1/2"
Machine Screw

3

- Attach front panel to cart with #8-32x3/8" sheet metal screws.



Qty: 6
#8-32X3/8"
Sheet Metal Screw

4

- Turn assembly upside down.
- Insert axle rod into wheel, Axle Spacer, legs and other Axle Spacer and wheel. Attach with (1) 8mm flat washer and hitch pin.

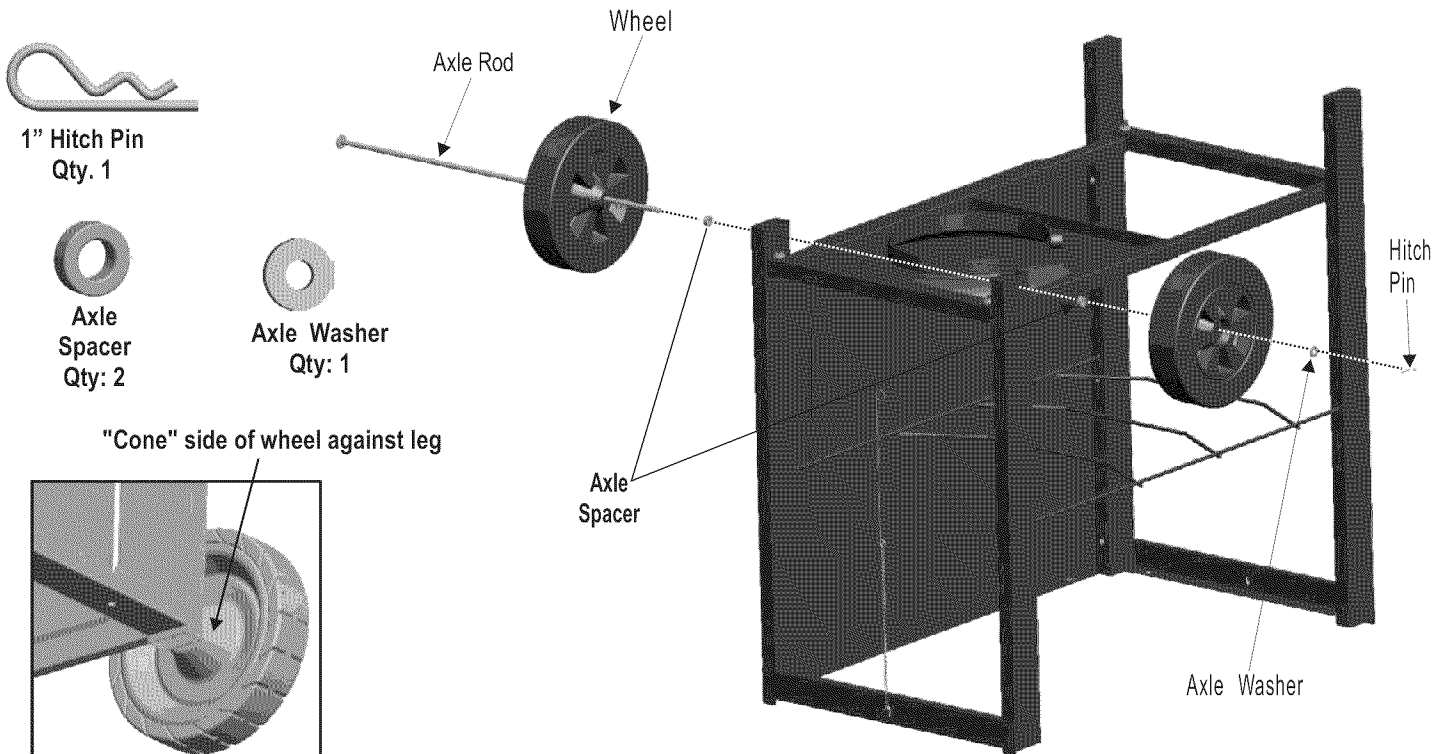

5

- Stand cart upright.
- This step requires two people to lift and position grill head onto cart.
- Carefully lower the grill head onto the cart. Make sure the regulator hose is hanging outside the cart. Attach with **1/4"-20x1/2" machine screws**.

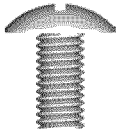

Qty: 4
1/4"-20x1/2"
Machine Screw

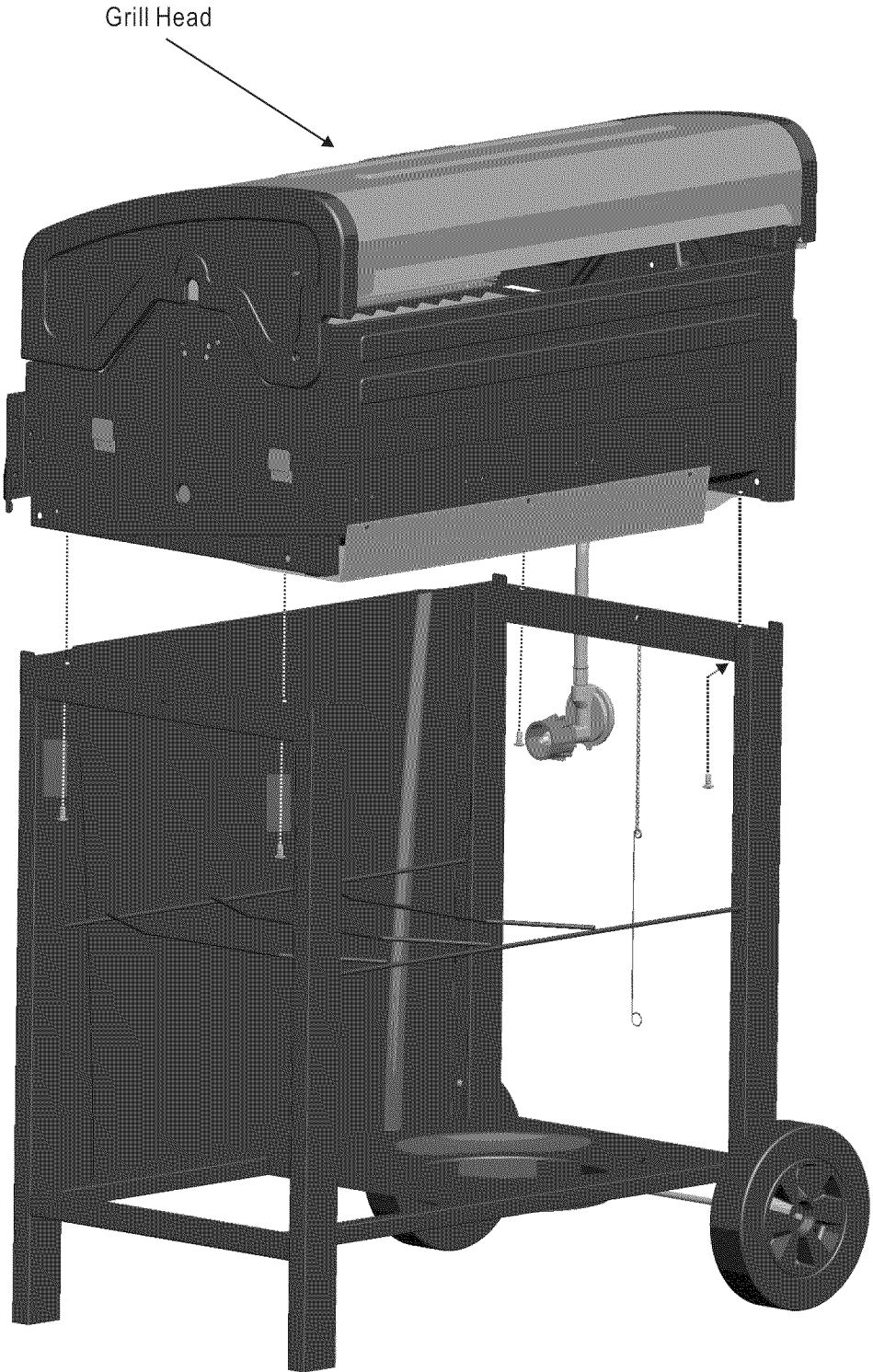

Grill Head

6

- Hook side wall of shelf over support brackets on side of firebox (A).
- Inside firebox insert 7x15 fiber washers and 1/4"-20x1/2" machine screws as shown (B).
- Attach shelf with flange nuts on each side. (C).

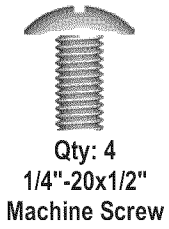
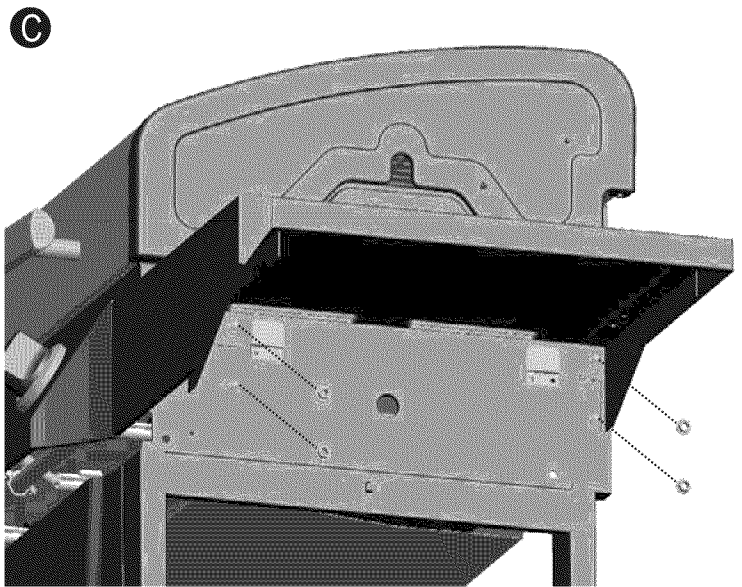
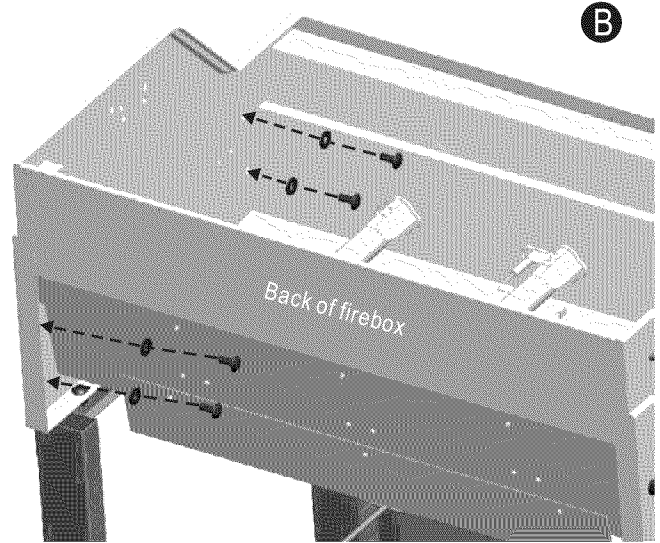
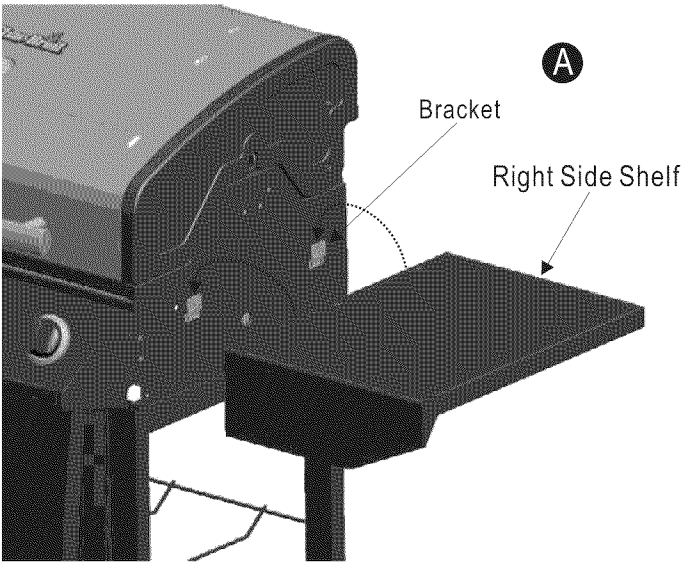

7

- Attach fascia to firebox with #8-32x3/8" sheet metal screws.

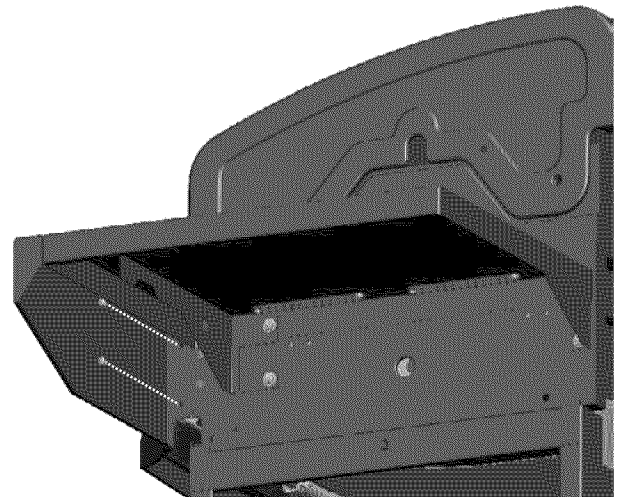

8

- Hook side wall of sideburner shelf over support brackets on side of firebox (A).
- Inside firebox insert 7x15 fiber washers and 1/4"-20x1/2" machine screws as shown (B).
- Attach sideburner shelf with flange nuts on each side. (C).

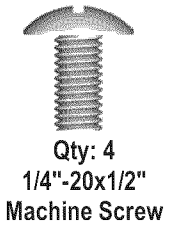
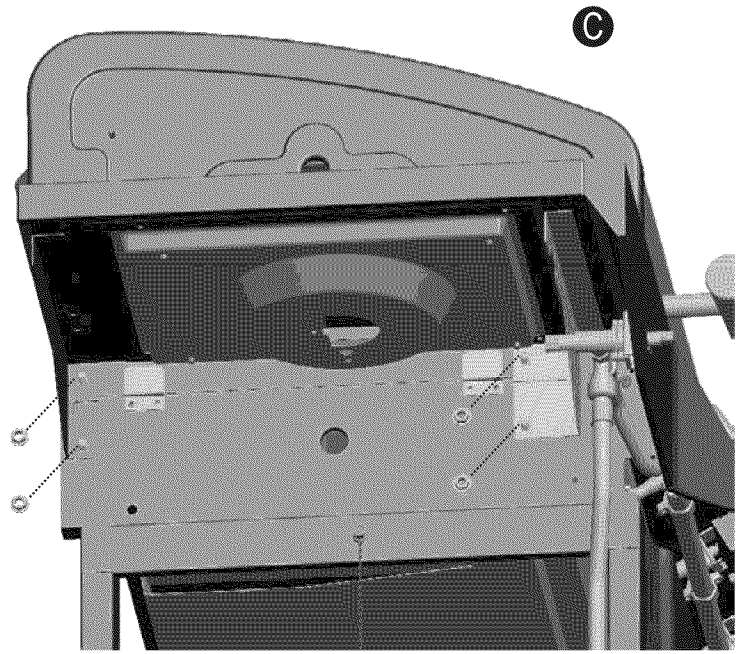
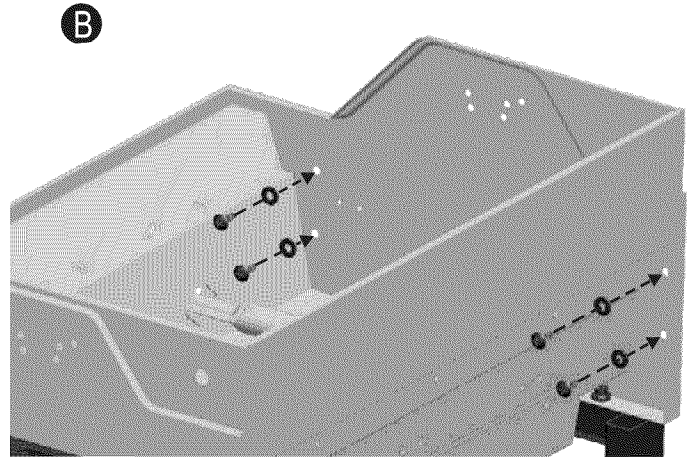
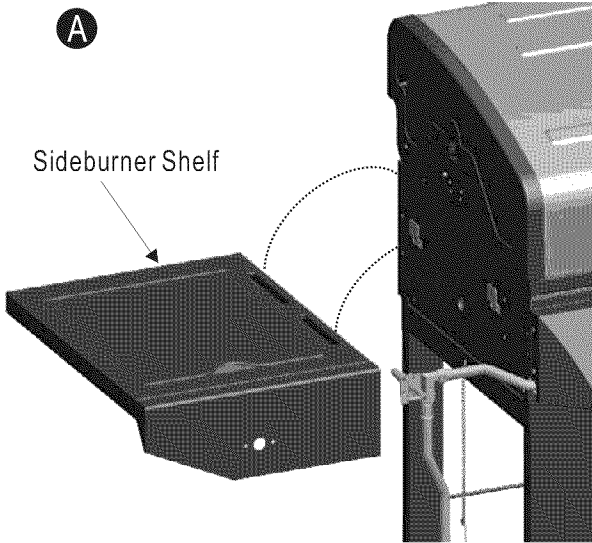

9

- Attach fascia to firebox with #8-32x3/8" sheet metal screws.

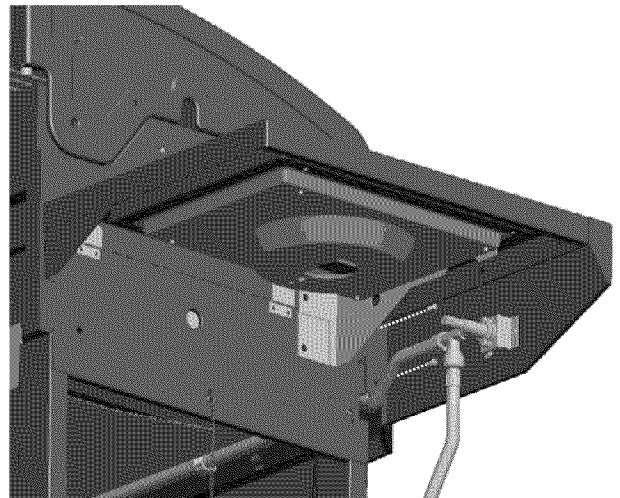

10

- Attach sideburner bezel and valve with #8-32x3/8" machine screws (A).
- Place sideburner into shelf. Make sure valve is inside sideburner tube. Attach sideburner with wing nut (B). Hook burner clip to sideburner tube and around manifold. Attach sideburner ignitor wire (C)
- Press sideburner control knob onto valve stem (D).
- Place grate onto sideburner shelf (E).

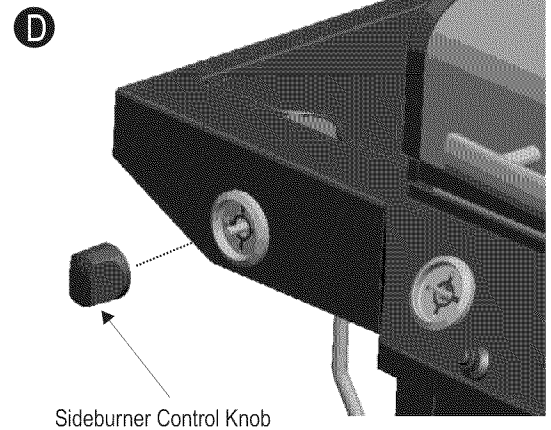
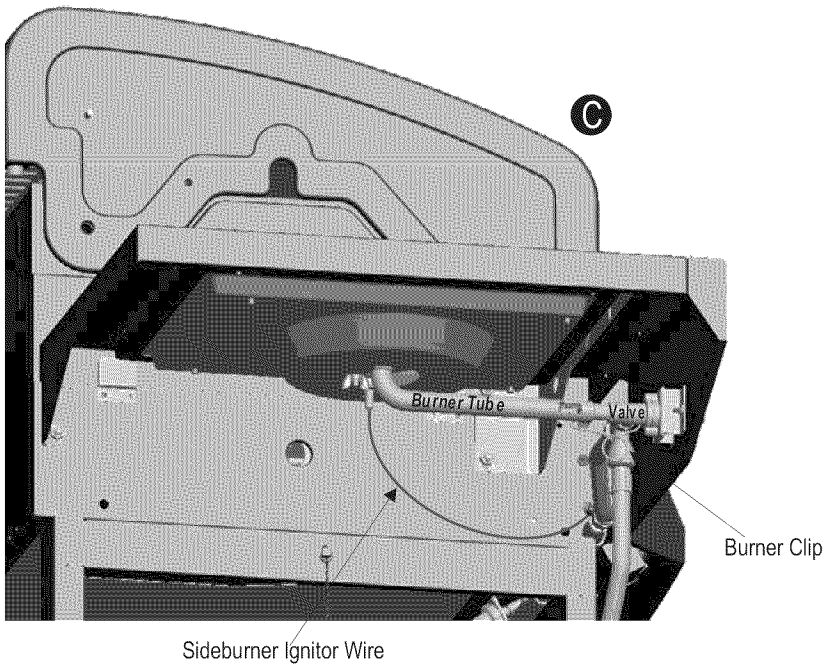
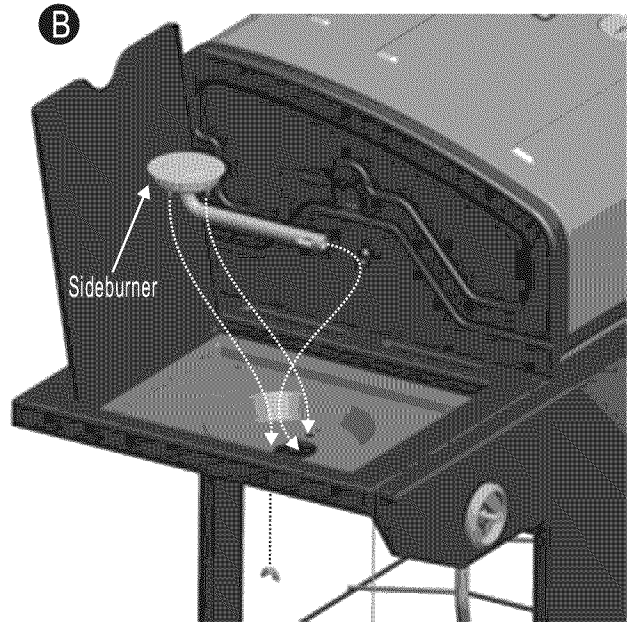
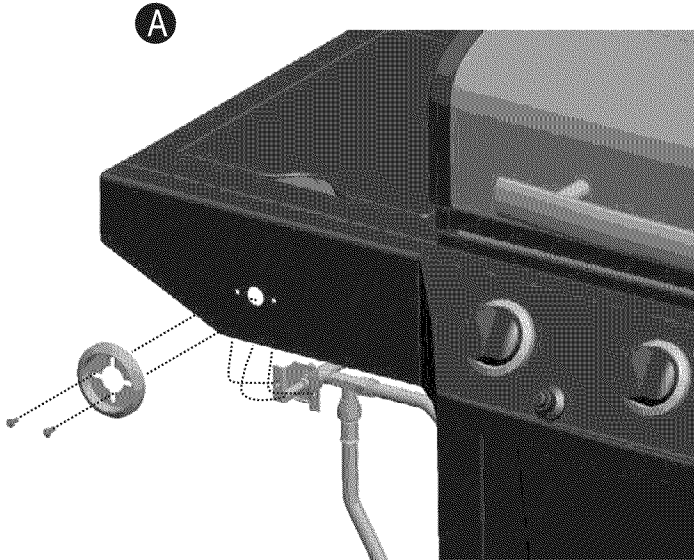

Correctly assembled burner-to-valve engagement

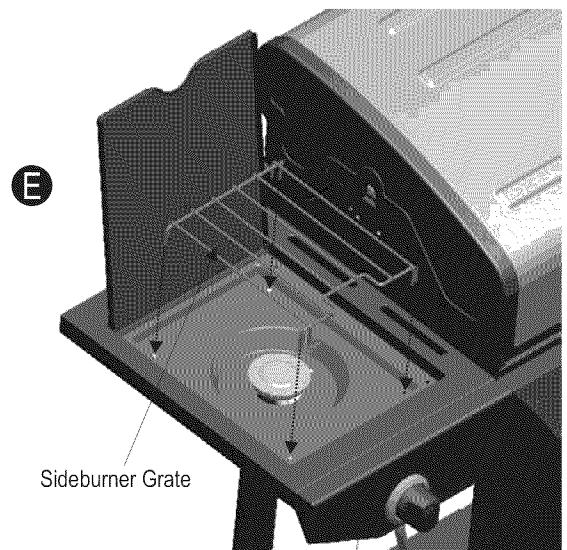

11

- Place heat tents over burners by inserting tabs into slots in front of firebox.
- Opposite ends of heat tents rest on pins in back of firebox.

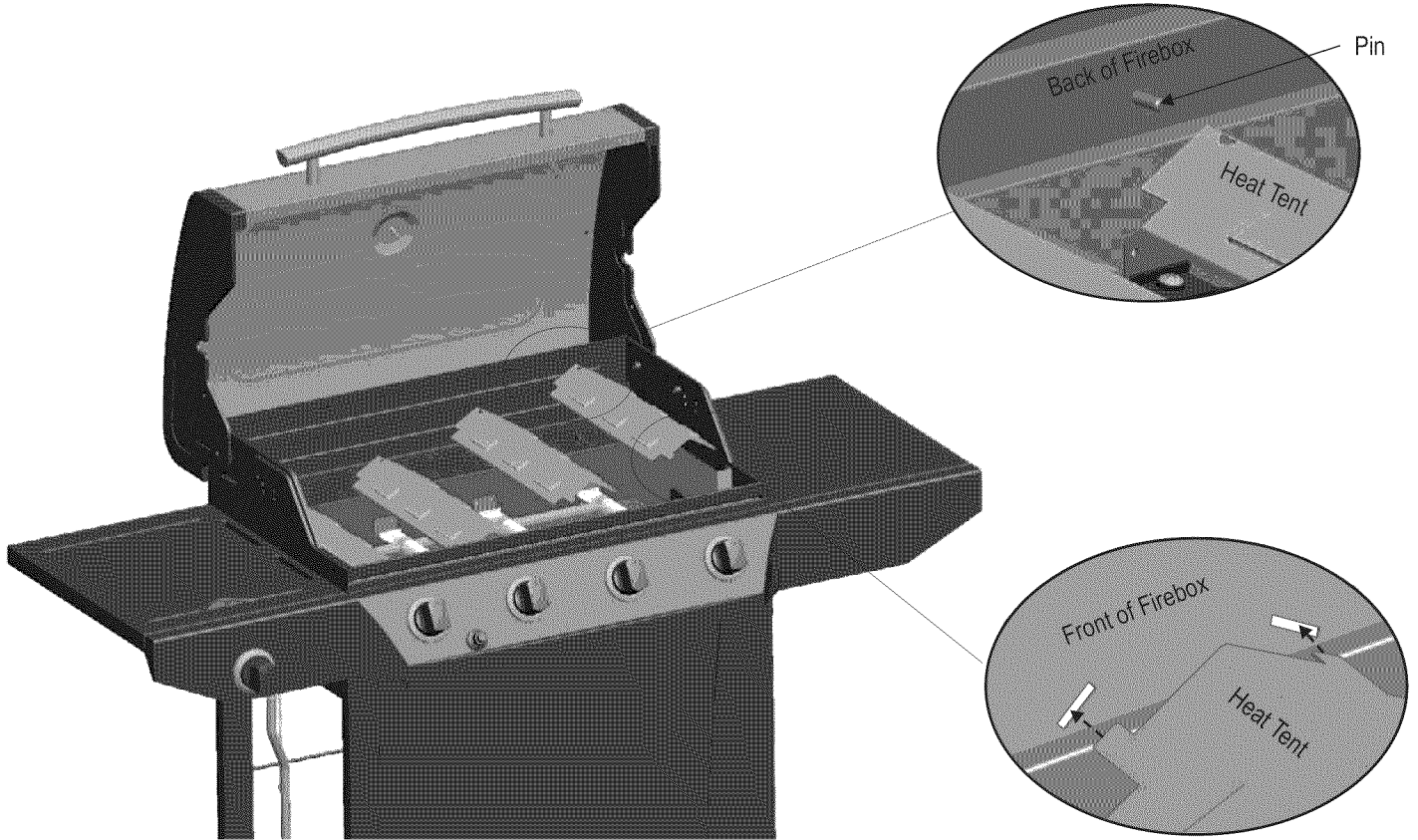

12

- Place cooking grates onto grate rests.
- Insert ends of Swing Away pivot wire into holes in sides of grill lid. Insert ends of Swing Away leg wire into holes in sides of firebox.
NOTE: Pivot and leg wires, running side-to-side, should be under wires running front-to-back. If pivot and leg wires are on top, Swing Away is installed upside-down.
- Unscrew ignitor cap and place AAA battery into ignitor slot with positive end (+) facing outward. Screw ignitor cap onto ignitor.

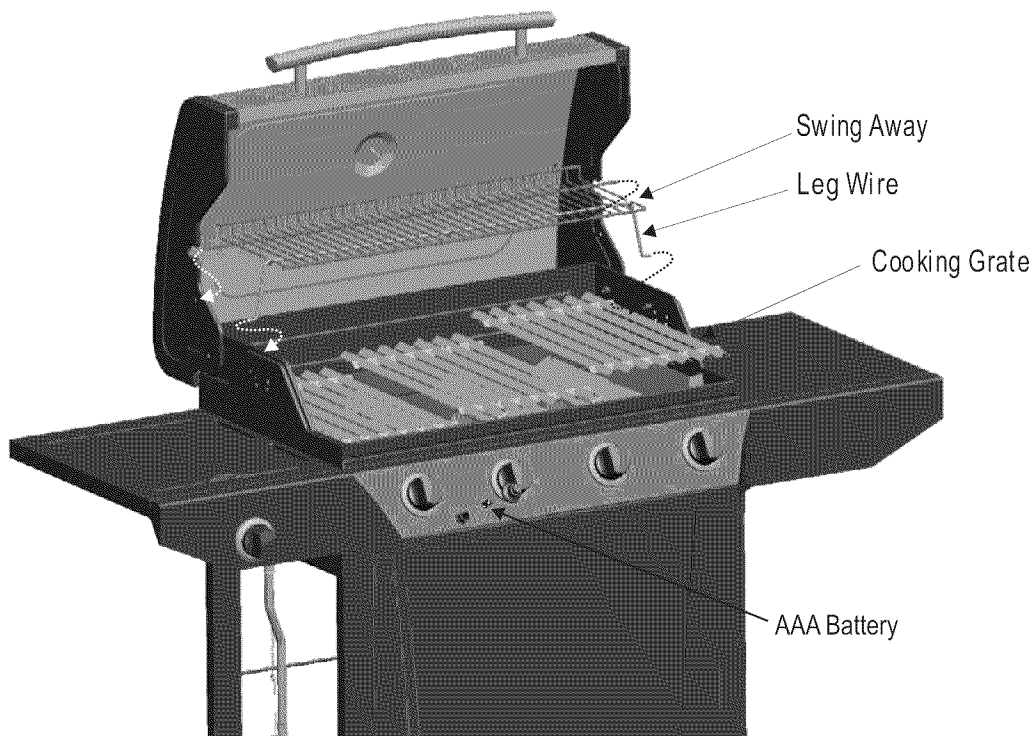

13

- Hang grease cup clip from bottom of firebox and place grease cup into grease clip.

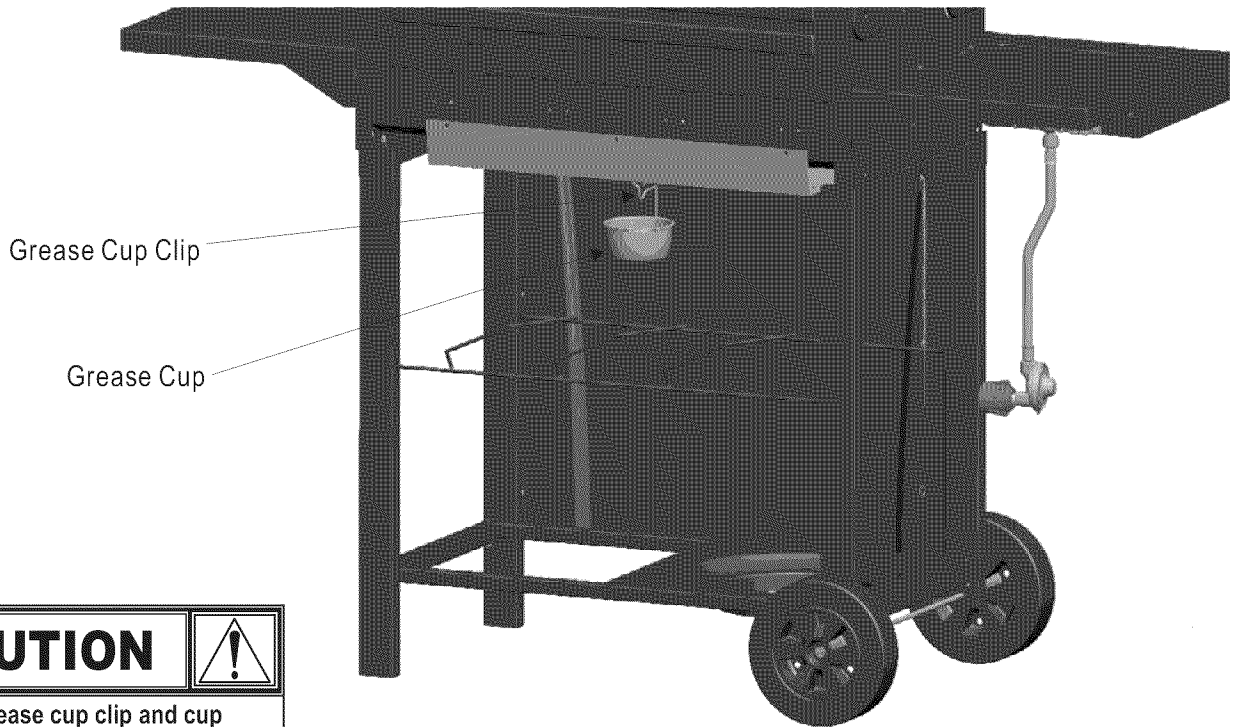

| | | |
|---|----------------|--|
| | CAUTION | |
| Failure to install grease cup clip and cup will cause hot grease to drip from bottom of grill with risk of fire or property damage. | | |

14

- LP tank is sold separately. Use only with an OPD (over-fill protection device) equipped LP tank. Fill and leak check before attaching to grill and regulator.
- Place LP tank into hole in bottom shelf with tank collar opening facing to side as shown. Finger tighten tank thumbscrew to hold LP tank securely in place.

See Use and Care section to correctly Leak Test and perform the Burner Flame Check

| | | |
|---|----------------|--|
| | CAUTION | |
| • Failure to install tank correctly may allow gas hose to be damaged in operation, resulting in the risk of fire. | | |

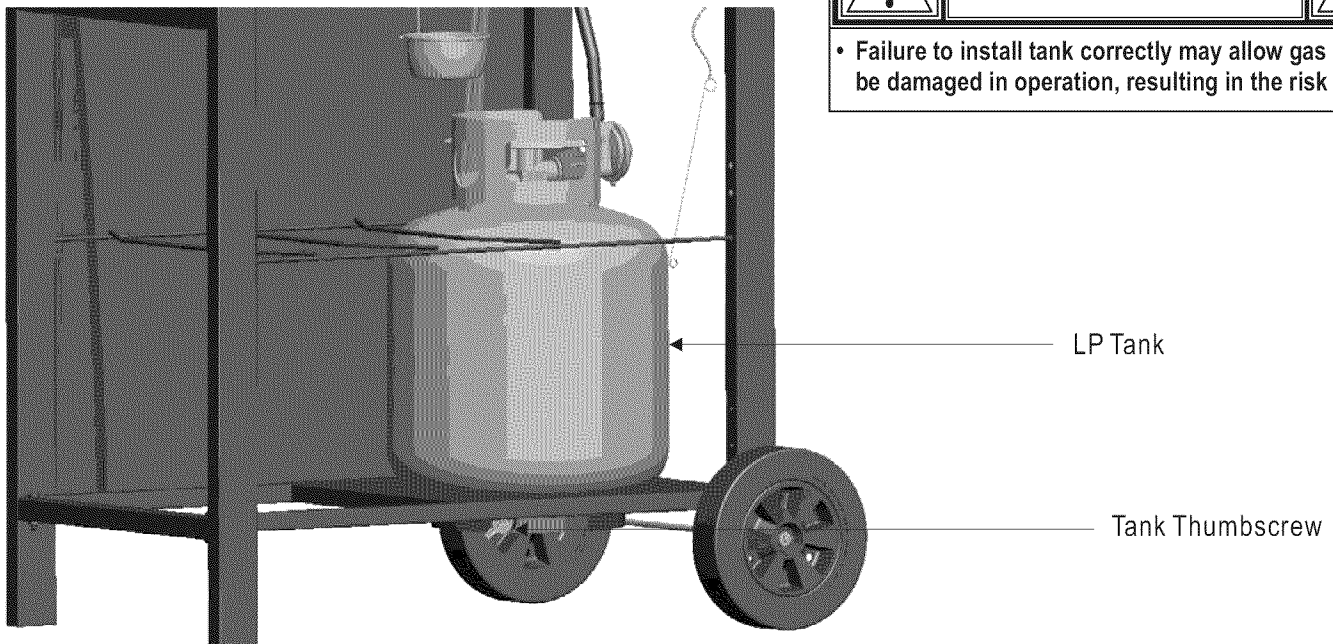

EMERGENCIES: If a gas leak cannot be stopped, or a fire occurs due to gas leakage, call the fire department.

| Emergencies | Possible Cause | Prevention/Solution |
|---|--|---|
| Gas leaking from cracked/cut/burned hose. | • Damaged hose. | • Turn off gas at LP cylinder or at source on natural gas systems. If anything but burned, replace valve/hose/regulator. If burned, discontinue use of product until a plumber has investigated cause and corrections are made. |
| Gas leaking from LP cylinder. | • Mechanical failure due to rusting or mishandling. | • Replace LP cylinder. |
| Gas leaking from LP cylinder valve. | • Failure of cylinder valve from mishandling or mechanical failure. | • Turn off LP cylinder valve. Return LP cylinder to gas supplier. |
| Gas leaking between LP cylinder and regulator connection. | • Improper installation, connection not tight, failure of rubber seal. | • Turn off LP cylinder valve. Remove regulator from cylinder and visually inspect rubber seal for damage. See LP Cylinder Leak Test and Connecting Regulator to the LP Cylinder. |
| Fire coming through control panel. | • Fire in burner tube section of burner due to blockage. | • Turn off control knobs and LP cylinder valve. Leave lid open to allow flames to die down. After fire is out and grill is cold, remove burner and inspect for spider nests or rust. See Natural Hazard and Cleaning the Burner Assembly pages. |
| Grease fire or continuous excessive flames above cooking surface. | • Too much grease buildup in burner area. | • Turn off control knobs and LP cylinder valve. Leave lid open to allow flames to die down. After cooling, clean food particles and excess grease from inside firebox area, grease tray, and other surfaces. |

Troubleshooting

| Problem | Possible Cause | Prevention/Solution |
|---|--|---|
| <p>Burner(s) will not light using ignitor. (See Electronic Ignition Troubleshooting also)</p> <p><i>Continued on next page.</i></p> | <p>GAS ISSUES:</p> <ul style="list-style-type: none"> • Trying to light wrong burner. • Burner not engaged with control valve. • Obstruction in burner. • No gas flow. • Vapor lock at coupling nut to LP cylinder. • Coupling nut and LP cylinder valve not fully connected. <p>ELECTRICAL ISSUES:</p> <ul style="list-style-type: none"> • Electrode cracked or broken; "sparks at crack." • Electrode tip not in proper position. • Wire and/or electrode covered with cooking residue. • Wires are loose or disconnected. • Wires are shorting (sparking) between ignitor and electrode. • Dead battery. | <ul style="list-style-type: none"> • See instructions on control panel and in Use and Care section. • Make sure valves are positioned inside of burner tubes. • Ensure burner tubes are not obstructed with spider webs or other matter. See cleaning section of Use and Care. • Make sure LP cylinder is not empty. If LP cylinder is not empty, refer to "Sudden drop in gas flow." • Turn off knobs and disconnect coupling nut from LP cylinder. Reconnect and retry. • Turn the coupling nut approximately one-half to three-quarters additional turn until solid stop. Tighten by hand only - do not use tools. • Replace electrode(s). <p>Main Burners:</p> <ul style="list-style-type: none"> • Tip of electrode should be pointing toward gas port opening on burner. The distance should be 1/8" to 1/4". Adjust if necessary. <p>Sideburner:</p> <ul style="list-style-type: none"> • Tip of electrode should be pointing toward gas port opening on burner. The distance should be 1/8" to 3/16". Adjust if necessary. <ul style="list-style-type: none"> • Clean wire and/or electrode with rubbing alcohol and clean swab. • Reconnect wires or replace electrode/wire assembly. • Replace ignitor wire/electrode assembly. • Replace with a new AA-size alkaline battery. |



REV00



Troubleshooting (continued)

| Problem | Possible Cause | Prevention/Solution |
|---|--|--|
| Burner(s) will not light using ignitor. (See Electronic Ignition Troubleshooting also) | ELECTRONIC IGNITION: •No spark, no ignition noise. •No spark, some ignition noise. •Sparks, but not at electrode or at full strength. | <ul style="list-style-type: none"> • See Section I of Electronic Ignition System. • See Section II of Electronic Ignition System. • See Section III of Electronic Ignition System. |
| Burner(s) will not match light. | <ul style="list-style-type: none"> •See “GAS ISSUES:” on previous page. •Match will not reach. •Improper method of match-lighting. | <ul style="list-style-type: none"> •Use long-stem match (fireplace match). •See “Match-Lighting” section of Use and Care. |
| Sudden drop in gas flow or low flame. | <ul style="list-style-type: none"> •Out of gas. •Excess flow valve tripped. •Vapor lock at coupling nut/LP cylinder connection. | <ul style="list-style-type: none"> •Check for gas in LP cylinder. •Turn off knobs, wait 30 seconds and light grill. If flames are still low, turn off knobs and LP cylinder valve. Disconnect regulator. Reconnect regulator and leak-test. Turn on LP cylinder valve, wait 30 seconds and then light grill. •Turn off knobs and LP cylinder valve. Disconnect coupling nut from cylinder. Reconnect and retry. |
| Flames blow out. | <ul style="list-style-type: none"> •High or gusting winds. •Low on LP gas. •Excess flow valve tripped. | <ul style="list-style-type: none"> •Turn front of grill to face wind or increase flame height. •Refill LP cylinder. •Refer to “Sudden drop in gas flow” above. |
| Flare-up. | <ul style="list-style-type: none"> •Grease buildup. •Excessive fat in meat. •Excessive cooking temperature. | <ul style="list-style-type: none"> •Clean burners and inside of grill/firebox. •Trim fat from meat before grilling. •Adjust (lower) temperature accordingly. |
| Persistent grease fire. | •Grease trapped by food buildup around burner system. | •Turn knobs to OFF. Turn gas off at LP cylinder. Leave lid in position and let fire burn out. After grill cools, remove and clean all parts. |
| Flashback... (fire in burner tube(s)). | •Burner and/or burner tubes are blocked. | •Turn knobs to OFF. Clean burner and/or burner tubes. See burner cleaning section of Use and Care. |
| Unable to fill LP cylinder. | •Some dealers have older fill nozzles with worn threads. | •The worn nozzles don’t have enough “bite” to engage the valve. Try a second LP dealer. |
| One burner does not light from other burner(s). | •Grease buildup or food particles in end(s) of carryover tube(s). | •Clean carry-over tube(s) with wire brush. |

Troubleshooting - Electronic Ignition

| Problem (Ignition) | Possible Cause | Check Procedure | Prevention/Solution |
|---|--|--|--|
| SECTION I No sparks appear at any electrodes when control knob turned to  ; no noise can be heard from spark module. | <ul style="list-style-type: none"> •Battery not installed properly. •Dead battery. •Button assembly not installed properly. •Faulty spark module. | <ul style="list-style-type: none"> •Check battery orientation. •Has battery been used previously? •Check to insure threads are properly engaged. Button should travel up and down without binding. •If no sparks are generated with new battery and good wire connections, module is faulty. | <ul style="list-style-type: none"> •Install battery (make sure that “+” and “-” connectors are oriented correctly, with “+” end up and “-” end down.) •Replace battery with new AA-size alkaline battery. •Unscrew button cap assembly and reinstall, making sure threads are aligned and engaged fully. •Replace spark module assembly. |
| SECTION II No sparks appear at any electrodes when control knob turned to  ; noise can be heard from spark module. | <ul style="list-style-type: none"> •Output lead connections not connected. | <ul style="list-style-type: none"> •Are output connections on and tight? | <ul style="list-style-type: none"> •Remove and reconnect all output connections at module and electrodes. |
| SECTION III Sparks are present but not at all electrodes and/or not at full strength | <ul style="list-style-type: none"> •Output lead connections not connected. •Arcing to grill away from burner(s). •Weak battery. •Electrodes are wet. •Electrodes cracked or broken “sparks at crack”. | <ul style="list-style-type: none"> •Are output connections on and tight? •If possible, observe grill in dark location. Operate ignition system and look for arcing between output wires and grill frame. •All sparks present but weak or at slow rate. •Has moisture accumulated on electrode and/or in burner ports? •Inspect electrodes for cracks. | <ul style="list-style-type: none"> •Remove and reconnect all output connections at module and electrodes. •If sparks are observed other than from burner(s), wire insulation may be damaged. Replace wires. •Replace battery with a new AA-size alkaline battery. •Use paper towel to remove moisture. •Replace cracked or broken electrodes. |

NOTES

NOTES

NOTES

Please register your product online at:

www.charbroil.com/register

(If you register online, you do not need to send in this registration card.)

PLEASE FILL OUT THIS CARD AND ATTACH A COPY OF YOUR SALES RECEIPT. RETURN IT WITHIN 10 DAYS OF PURCHASE. FAILURE TO RETURN MAY AFFECT YOUR WARRANTY COVERAGE. FOR WARRANTY SERVICE PROOF OF PURCHASE WILL BE REQUIRED. THIS WARRANTY IS NON-TRANSFERABLE.

LLENE ESTA TARJETA Y DEVUELVALA DENTRO DE LOS 10 DIAS DE LA COMPRA. SI NO LA DEVUELVE, PUEDE VERSE AFECTADA SU COBERTURA DE GARANTIA. PARA EL SERVICIO DE GARANTIA ES NECESARIO QUE PRESENTE SU COMPROBANTE DE COMPRA. CONSERVE LA FACTURA. ESTA GARANTIA ES INTRANSFERIBLE.

VEUILLEZ COMPLETER CETTE CARTE ET LA RETOURNER DANS LES 10 JOURS SUIVANT L'ACHAT. LA COUVERTURE DE VOTRE GARANTIE POURRAIT EN ETRE AFFECTEE SI VOUS NE LE FAITES PAS. POUR OBTENIR LE SERVICE SOUS GARANTIE, UNE PREUVE D'ACHAT DOIT ETRE PRESENTEE. VEUILLEZ CONSERVER VOTRE FACTURE. LA PRESENTE GARANTIE N'EST PAS TRANSFERABLE.

1 First Name/Nombre/Prénom Initial/Inicial/Initiale Last Name/Apellido/Nom de famille

Address (number and street)/Dirección (número y calle)/Adresse (numéro et rue) Apt Number/Nº de apart./Nº d'appt.

City/Ciudad/Ville State/Estado/Province Zip Code/Código Zip/Code postal

2 E-mail Address/Dirección de correo electrónico/Adresse électronique

If you voluntarily provide us with your email address, you give us permission to use your email address to send you offers that may interest you. Si nos informa voluntariamente su dirección de correo electrónico, nos da permiso para usarlo a fin de enviarle ofertas que pueden interesarle. Si vous choisissez de nous fournir votre adresse électronique, vous nous donnez la permission de l'utiliser pour vous faire part d'offres spéciales susceptibles de vous intéresser.

(Example: your name @ your host.com) (Ejemplo: su nombre@su host.com) (Exemple : votre nom@votre hôte.com)

10 Attach copy of your sales receipt here
Adjunte aquí la copia de su recibo de compra
Veillez attacher une copie de votre reçu ici.

3 Phone Number/Número telefónico/Numéro de téléphone

6 Date of Purchase/Fecha de compra/Date de l'achat

4 **IMPORTANT!;IMPORTANTE!;IMPORTANT!**
Write Serial Number and Model Number in spaces below.
Escriba en los espacios de abajo el número de serie y el número de modelo.
Inscrivez le numéro de série et le numéro de modèle dans les espaces ci-dessous.

7 Store Name/Nombre de la tienda/Nom du magasin

8 Purchase Price/Precio de compra/Prix d'achat

\$ _____ .00

5 Your Gender/Sexo/Sexe :

1. Male/Masculino/Masculin

2. Female/Femenino/Féminin

9 Which product are you registering?

¿Qué producto está registrando?

Quel produit enregistrez-vous?

1. Gas Grill/Parrilla a gas/Gril au gaz
2. Electric Grill/Parrilla eléctrica/Gril électrique
3. Smoker/Ahumador/Fumoir
4. Charcoal Grill/Parrilla a carbón/Barbecue au charbon
5. Charcoal Smoker/Ahumador a carbón/Fumoir au charbon
6. Outdoor Fireplace/Chimenea para exteriores/Foyer extérieur
7. Cooker/Fryer / Cocina/freidora / Cuisieur/Friteuse
8. Other/Otro/Autre

Mail to: / Envíelo a:
Consumer Warranty Service
P. O. Box 1240
Columbus, GA 31902-1240

Thank you for completing this questionnaire. Your answers will help us and other companies reach you with offers that may interest you. If you prefer not to receive these offers, please check here .

Gracias por completar este cuestionario. Sus respuestas nos ayudarán, a nosotros y a otras compañías, a llegar a usted con ofertas que puedan resultarle de interés. Si prefiere no recibir estas ofertas, por favor marque aquí .

Merci d'avoir bien voulu remplir ce questionnaire. Vos réponses nous aideront et aideront d'autres compagnies à vous communiquer des offres spéciales susceptibles de vous intéresser. Si vous préférez ne pas recevoir d'informations concernant ces offres spéciales, veuillez cocher ici .

REGTEMP REV00



Here's what you can find at
www.charbroil.com

- Register your Char-Broil® product
- Get information about our products
- Our replacement parts
- Reliable customer support
- Delicious recipes
- Char-Broil® on-line store
- *Sizzle On The Grill*™ E-newsletter
- And much more!



Please visit us at **www.charbroil.com** and click on the *Buy Online* link to find grilling tools and accessories, maintenance items, covers, grill parts, Char-Broil® grills and cookers, and of course, the famous Oklahoma Joe's® sauces, rubs, and marinades. We also have a *Special Offers* section, so be sure to check often for specials deals.

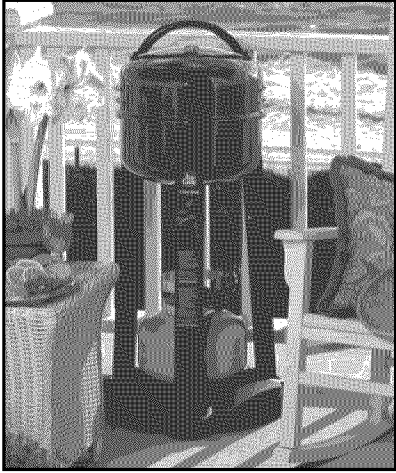

In addition to the online store, charbroil.com offers you a wealth of information regarding Char-Broil® gas, charcoal, electric, and new infrared grills and cookers.

Be sure to check out our many grilling recipes and don't forget to sign up for our exciting newsletter *Sizzle on the Grill*™ to stay updated on new recipes, contests, and the latest happenings here at Char-Broil®.

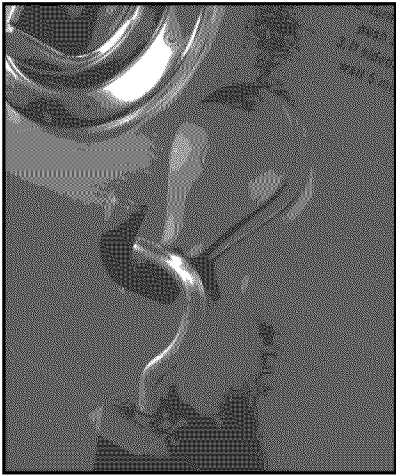

Charbroil.com also offers on-line customer support for Char-Broil® products.

Thank you for support, and HAPPY GRILLING!

www.charbroil.com
For all your grilling needs!