

W009152A

W009153A

# WORKPRO

## ORIGINAL OPERATING INSTRUCTIONS CORDLESS DRILL DRIVER

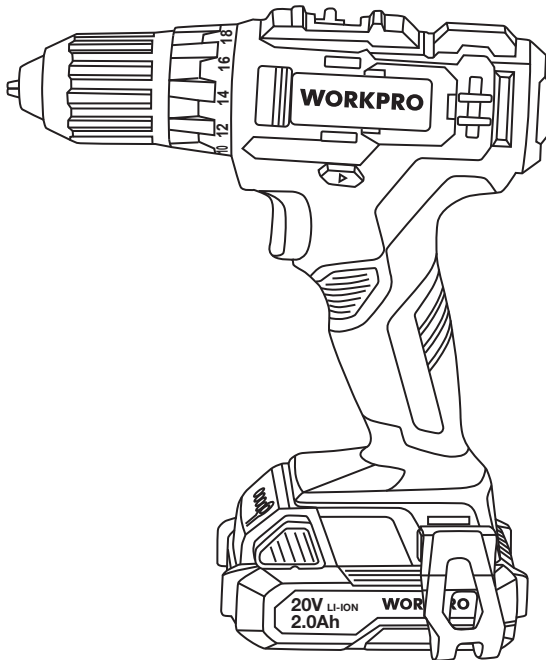

Thank you for buying a WORKPRO 20V cordless drill driver set. Your new cordless drill driver has been engineered and manufactured to WORKPRO's high standard for dependability, ease of operation, and operator safety. Properly cared for, it will give you years of rugged, trouble-free performance.



**WARNING:** To reduce the risk of injury, the user must read and understand the operator's manual.

**SAVE THIS MANUAL FOR FUTURE REFERENCE**



Distributed by  
Hangzhou GreatStar Industrial Co., Ltd.  
No.35 Jiujuan Road, Jiubao Town,  
Hangzhou 310019, China  
[www.greatstartools.com](http://www.greatstartools.com)

## TABLE OF CONTENTS

Caution .....	2
Environmental protection .....	2
Disposal of an exhausted battery pack .....	2
Description of symbols .....	2
General safety rules .....	3-4
Additional safety instructions .....	4
Additional safety instructions for the charger .....	4-5
Additional safety instructions related to the battery pack and battery safety .....	5-6
When to charge the battery .....	6
Component list and specifications .....	7
Operating instructions .....	8-10
Problem solution .....	10
Maintenance .....	11
Battery capacity indicator and charger indicator .....	11

**⚠ CAUTION!** Carefully read through this entire Instruction Manual before using your new Workpro Power Tool. Take special care to heed the Cautions and Warnings. Your Workpro power tool has many features that will make your job faster and easier. Safety, performance, and dependability have given top priority in the development of this tool, making it easy to maintain and operate.

## ENVIRONMENTAL PROTECTION



This product has been marked with a symbol relating to removing electric and electronic waste. This means that this product shall not be discarded with household waste but that it shall be returned to a collection system.

It will then be recycled or dismantled in order to reduce the impact on the environment. Electric and electronic equipment can be hazardous for the environment and for human health since they contain hazardous substances.

## DISPOSAL OF AN EXHAUSTED BATTERY PACK



To preserve natural resources, please recycle or dispose of the battery pack properly. This battery pack contains Li-ion batteries. Consult your local waste authority for information regarding available recycling and/or disposal options. Discharge your battery pack by operating your tool, then remove the battery pack from the tool housing and cover the battery pack connections with heavy-duty adhesive tape to prevent short circuit and energy discharge. Do not attempt to open or remove any of the components.

## DESCRIPTION OF SYMBOLS

The rating plate on your tool may show symbols. These represent important information about the product or instructions on its use.



Wear hearing protection.  
Wear eye protection.  
Wear breathing protection.



Double insulated for additional protection.



Do not expose to rain or water



Do not burn



Read these operating instructions well before you use the tool.



Risk of injury when instructions are not followed



Risk of electric shock



Do not throw the electronic waste products into the domestic waste refuse. Such products must be delivered to a recycling centre.

## GENERAL SAFETY RULES

**⚠️WARNING. Read all safety warnings and all instructions. Failure to follow the warnings and instructions may result in electric shock, fire and/or serious injury.**

**Save all warnings and instructions for future reference.**

### 1. Work area safety

- a. Keep work area clean and well lit. Cluttered or dark areas invite accidents.
- b. Do not operate power tools in explosive atmospheres, such as in the presence of flammable liquids, gases or dust. Power tools create sparks which may ignite the dust or fumes.
- c. Keep children and bystanders away while operating a power tool. Distractions can cause you to lose control.

### 2. Electrical safety

- a. Power tool plugs must match the outlet. Never modify the plug in any way. Do not use any adapter plugs with earthed (grounded) power tools. Unmodified plugs and matching outlets will reduce risk of electric shock.
- b. Avoid body contact with earthed or grounded surfaces, such as pipes, radiators, ranges and refrigerators. There is an increased risk of electric shock if your body is earthed or grounded.
- c. Do not expose power tools to rain or wet conditions. Water entering a power tool will increase the risk of electric shock.
- d. Do not abuse the cord. Never use the cord for carrying, pulling or unplugging the power tool. Keep cord away from heat, oil, sharp edges or moving parts. Damaged or entangled cords increase the risk of electric shock.
- e. When operating a power tool outdoors, use an extension cord suitable for outdoor use. Use of a cord suitable for outdoor use reduces the risk of electric shock.
- f) If operating a power tool in a damp location is unavoidable, use a residual current device (RCD) protected supply. Use of an RCD reduces the risk of electric shock.

### 3. Personal safety

- a. Stay alert, watch what you are doing and use common sense when operating a power tool. Do not use a power tool while you are tired or under the influence of drugs, alcohol or medication. A moment of inattention while operating power tools may result in serious personal injury.
- b. Use personal protective equipment. Always wear eye protection. Protective equipment such as dust mask, non-skid safety shoes, hard hat, or hearing protection used for appropriate conditions will

reduce personal injuries.

- c. Prevent unintentional starting. Ensure the switch is in the off-position before connecting to power source and/or battery pack, picking up or carrying the tool. Carrying power tools with your finger on the switch or energising power tools that have the switch on invites accidents.
- d. Remove any adjusting key or wrench before turning the power tool on. A wrench or a key left attached to a rotating part of the power tool may result in personal injury.
- e. Do not overreach. Keep proper footing and balance at all times. This enables better control of the power tool in unexpected situations.
- f. Dress properly. Do not wear loose clothing or jewellery. Keep your hair, clothing and gloves away from moving parts. Loose clothes, jewellery or long hair can be caught in moving parts.
- g. If devices are provided for the connection of dust extraction and collection facilities, ensure these are connected and properly used. Use of dust collection can reduce dust-related hazards.
- h) Do not let familiarity gained from frequent use of tools allow you to become complacent and ignore tool safety principles. A careless action can cause severe injury within a fraction of a second.

### 4. Power tool use and care

- a. Do not force the power tool. Use the correct power tool for your application. The correct power tool will do the job better and safer at the rate for which it was designed.
- b. Do not use the power tool if the switch does not turn it on and off. Any power tool that cannot be controlled with the switch is dangerous and must be repaired.
- c. Disconnect the plug from the power source and/or the battery pack from the power tool before making any adjustments, changing accessories, or storing power tools. Such preventive safety measures reduce the risk of starting the power tool accidentally.
- d. Store idle power tools out of the reach of children and do not allow persons unfamiliar with the power tool or these instructions to operate the power tool. Power tools are dangerous in the hands of untrained users.
- e. Maintain power tools. Check for misalignment or binding of moving parts, breakage of parts and any other condition that may affect the power tool's operation. If damaged, have the power tool repaired before use. Many accidents are caused by poorly maintained power tools.
- f. Keep cutting tools sharp and clean. Properly maintained cutting tools with sharp cutting edges are less likely to bind and are easier to control.

- g. Use the power tool, and accessories in accordance with these instructions, taking into account the working conditions and the work to be performed. Use of the power tool for operations different from those intended could result in a hazardous situation.
- h. Keep handles and grasping surfaces dry, clean and free from oil and grease. Slippery handles and grasping surfaces do not allow for safe handling and control of the tool in unexpected situations.

## 5. Battery tool use and care

- a. Ensure the switch is in the off position before inserting battery pack. Inserting the battery pack into power tools that have the switch on invites accidents.
- b. Recharge only with the charger specified by the manufacturer. A charger that is suitable for one type of battery pack may create a risk of fire when used with another battery pack.
- c. Use power tools only with specifically designated battery packs. Use of any other battery packs may create a risk of injury and fire.
- d. When battery pack is not in use, keep it away from other metal objects like paper clips, coins, keys, nails, screws, or other small metal objects that can make a connection from one terminal to another. Shorting the battery terminals together may cause burns or a fire.
- e. Under abusive conditions, liquid may be ejected from the battery; avoid contact. If contact accidentally occurs, flush with water. If liquid contacts eyes, additionally seek medical help. Liquid ejected from the battery may cause irritation or burns.

## 6. Service

- a. Have your power tool serviced by a qualified repair person using only identical replacement parts. This will ensure that the safety of the power tool is maintained.

## ADDITIONAL SAFETY INSTRUCTIONS

Wear ear protectors.

Exposure to noise can cause hearing loss.

Loss of control can cause personal injury.

- If possible, always use clamps or a vice to hold your work piece.
- Always switch off before you put the tool down.
- Ensure that the lighting is adequate.
- Do not put pressure on the tool, such that it slows the motor down.
- Keep the area free of tripping hazards.
- Do not let anyone under 18 years operate this tool.
- Only use accessories in good condition.
- Do not touch the blade after operation. It will be very hot.

- Keep your hands away from under the workpiece.
- Never use your hands to remove sawdust, chips or waste close by the blade.
- Rags, cloths, cord, string and the like should never be left around the work area.
- Support the work properly.
- If you are interrupted when operating the tool, complete the process and switch off before looking up.
- Periodically check that all nuts, bolts and other fixings are properly tightened.
- When using the tool, use safety equipment including safety glasses or shield, ear defenders, and protective clothing including safety gloves.  
Wear a dust mask if the cutting or sanding operation creates dust.

If in doubt, do not plug in the tool. Using a power source with a voltage less than the nameplate rating is harmful to the motor.

The tool must be used only for its prescribed purpose. Any use other than those mentioned in this Manual will be considered a case of misuse. The user and not the manufacturer shall be liable for any damage or injury resulting from such cases of misuse.

To use this tool properly, you must observe the safety regulations, the assembly instructions and the operating instructions to be found in this Manual. All persons who use and service the machine have to be acquainted with this Manual and must be informed about its potential hazards.

Children and frail people must not use this tool. Children should be supervised at all times if they are in the area in which the tool is being used. It is also imperative that you observe the accident prevention regulations in force in your area. The same applies for general rules of occupational health and safety.

The manufacturer shall not be liable for any changes made to the tool nor for any damage resulting from such changes. Even when the tool is used as prescribed it is not possible to eliminate all residual risk factors. The following hazards may arise in connection with the tool's construction and design:

Damage to the lungs if an effective dust mask is not worn.

Damage to hearing if effective ear defenders are not worn.

## ADDITIONAL SAFETY INSTRUCTIONS FOR THE CHARGER

- Your Workpro tool with Lithium Ion batteries may only be charged with the specific designed Workpro Lithium Ion battery charger purchased with the tool. **IT IS DANGEROUS TO USE ANY OTHER BATTERY CHARGER TO CHARGE YOUR TOOL.** Do not attempt to charge the battery pack with any other charger than the one supplied.
- Before using the charger, read all the instructions, labels and cautionary markings on the charger and battery pack as well as the instructions on using the

battery pack.

- Do not use the charger if it has been subjected to a heavy knock, dropped or otherwise damaged in anyway. Take the charger to an authorised service centre for a check or repair.
- Do not disassemble the charger. Opening or removing covers may expose you to dangerous voltages or other risks. Incorrect reassembly can cause electric shock when you use the tool or charger again. Take the charger to a power tool repair centre when service or repair is required. Incorrect re-assembly may result in the risk of fire, electric shock or electrocution. To reduce the risk of electric shock, do not disassemble any part of the product.

**⚠ DANGER.** If the battery pack is cracked or damaged in any other way, do not insert it in the charger

- Do not plug anything other than your Workpro tool into the charger, as other objects may touch dangerous voltage points or short out parts, which could result in fire or electric shock.
- Do not place the tool or charger on an uneven surface, as a fall may cause serious damage.
- Never place the tool or charger near or over a heat source such as a radiator or heater.
- Do not operate the charger in a cabinet or other enclosure unless proper ventilation is provided.
- Use the battery charger indoors only.

**⚠ WARNING.** Do not allow any liquid to come into contact with the charger. There is a danger of electric shock. Do not position the tool or battery charger near water; for example, near a sink, wash bowl or toilet. Do not spill liquid of any kind on the tool or charger. Doing so may short out parts, causing damage to the product and creating the risk of fire or electric shock.

- To reduce the risk of an electric shock, unplug the charger from the power supply before attempting to clean it. To clean tool or charger, wipe with a damp cloth. Use of any other cleaners is not recommended.
- Do not place any object on to, or allow anything to rest on the charger.
- Make sure that the charger cable is positioned where it will not be stepped on, tripped over or otherwise subjected to damage or stress. Keep the lead away from operating machinery.
- Do not pull on the lead of the charger to disconnect it from the mains power socket.
- Do not use an extension cord unless it is absolutely necessary. The use of an improper extension cord could cause the risk of fire, electric shock or electrocution.
- Never attempt to connect two chargers together.
- Do not charge batteries or use the tool and battery pack in locations where the temperature may be below 40°F or exceed 104°F such as alongside sheds or metal structures.
- The battery can be charged or operated at temperatures between 40° F and 104° F.

**Never charge your lithium ion battery below or above temperatures recommended otherwise fire or serious damage to the battery pack may occur.**

The most suitable temperatures to charge the battery pack are between 68° F -77° F.

- If you wish to charge a second battery pack, unplug the charger from the mains supply and leave it for at least 15 minutes. After this time you can charge a second battery pack.

## **ADDITIONAL SAFETY INSTRUCTIONS RELATED TO THE BATTERY PACK AND BATTERY SAFETY**

- Use only the WORKPRO batteries supplied with the WORKPRO Tool or WORKPRO-approved replacements.
- Do not use the battery to power any device other than the WORKPRO tool it was sold with.
- Charge the battery only with the WORKPRO charger supplied with the tool or WORKPRO-approved replacements and according to the instructions in the WORKPRO Instruction Manual.
- Do not charge the battery in a place where static electricity is generated nor let the battery touch something that is statically charged.
- The battery can be stored at temperatures between 40° F and 104° F.

**Never store or leave your lithium ion battery in temperatures over that recommended otherwise fire may occur.**

Do NOT store the Lithium Ion battery anywhere that the temperature can easily reach higher temperatures than recommended -this includes garden type sheds, and Vehicles where the inside temperature can climb to dangerous levels in the direct sunlight and on high temperature days. **THINK BEFORE LEAVING YOUR LITHIUM ION BATTERY PACK IN STORAGE.**

- The battery can be charged or operated at temperatures between 40° F and 104° F.  
**NEVER CHARGE YOUR LITHIUM ION BATTERY BELOW OR ABOVE TEMPERATURES RECOMMENDED OTHERWISE FIRE OR SERIOUS DAMAGE TO THE BATTERY PACK MAY OCCUR.**  
The most suitable temperatures to charge the battery pack are between 68 -77° F.
- Always allow the battery pack to cool down after charging, do not place it in a hot environment such as a metal shed or open trailer left in the sun.
- Take care where the tool is stored. Do not store in areas of corrosive fumes, or salt air or similar conditions. Try and store the tool in the packaging supplied with the tool.
- Do not dispose of the battery in a fire or put the battery into a microwave oven, conventional oven, dryer, or high-pressure container. Under these conditions, the battery may explode.
- Never attempt to open the battery pack, puncture the battery or subject the battery to strong physical shock.
- If the plastic housing of the battery pack breaks

open or cracks, immediately discontinue its use and do not recharge it. Ensure the battery pack clip is in good condition and will not allow the pack to fall free from the tool. If the clip is damaged or for any reason is not locking the pack in place Do Not continue to use.

- Stop using the battery if it exhibits abnormal heat, odour, colour, deformation, or is in an abnormal condition.
- If you detect leakage or a foul odour, it is especially important to keep the battery away from fire. If battery liquid leaks onto your skin or clothes, wash well with clean water immediately. If liquid leaking from the battery gets into your eyes, do not rub your eyes. Rinse your eyes well (for at least 10 minutes) with clean water, and consult a doctor immediately. Do not use a leaking battery.
- Handle batteries with care to avoid shorting the battery with conducting materials, such as nails, screws, metal watch bands, rings, bracelets, and keys. The battery may overheat and could burn you.
- After the battery has reached the end of its useful life, we recommend recycling the materials at your local municipal council recycling centre. DO NOT attempt to replace the battery cells in the battery

pack, repair or modify any part of the battery pack assembly.

- When recycling, make it nonconductive by applying insulating tape to the terminals located on the battery.

## **WHEN TO CHARGE THE BATTERY**

New batteries are shipped in a low charged condition and should be fully charged before Use. The battery pack can be recharged at any time during use, provided the pack is not overheated.

If the battery pack starts to cut out due to low voltage, or previous tasks undertaken can no longer be performed, it is suggested to stop using the tool and recharge the battery.

For storage, it is suggested to recharge the battery between 50% and 75% charge.

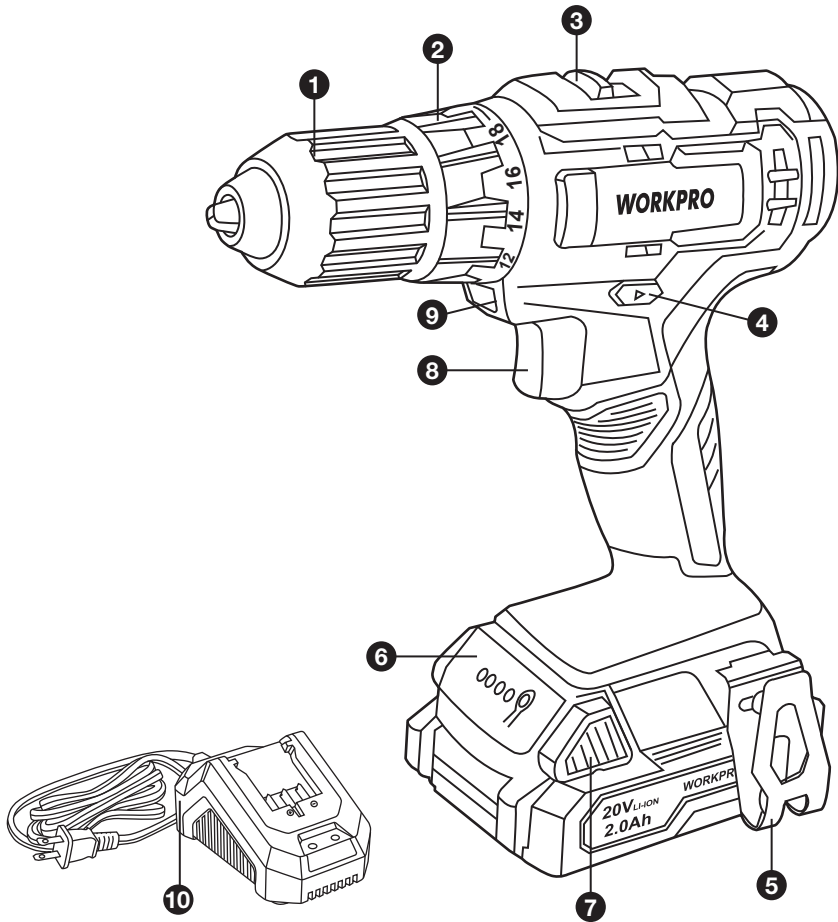

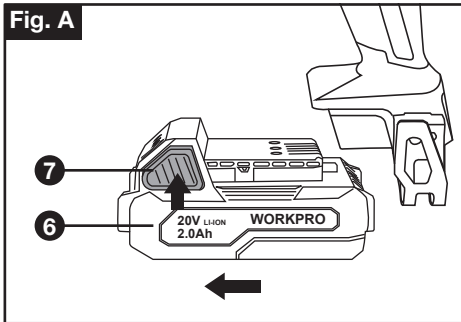
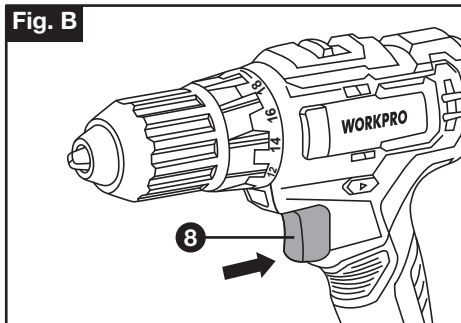
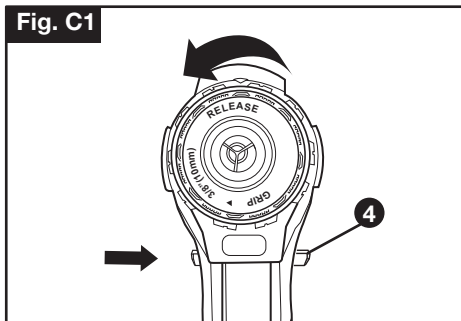
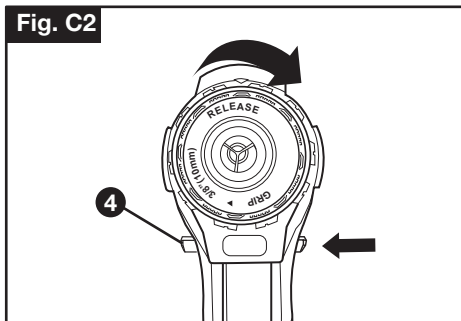
**Fig. A****Fig. B****Fig. C1****Fig. C2**

## OPERATING INSTRUCTIONS

### **⚠ WARNING!**

Drilling, sawing, sanding or machining wood products can expose you to wood dust, a substance known to the State of California to cause cancer. Avoid inhaling wood dust or use a dust mask or other safeguards for personal protection. For more information go to [www.P65Warnings.ca.gov](http://www.P65Warnings.ca.gov)



**NOTE:** Before using the tool, read the instruction book carefully.

### INTENDED USE

The machine is intended for driving in and loosening screws as well as for drilling in wood, metal and plastic.

### Before Putting Into Operation

#### A. Charging The Battery

The battery charger supplied is matched to the Li-ion battery installed in the machine. Do not use another battery charger.

The Li-ion battery is protected against deep discharging. When the battery is empty, the machine is switched off by means of a protective circuit: The tool holder no longer rotates.

In a warm environment or after heavy use, the battery pack may become too hot to permit charging. Allow time for the battery to cool down before recharging. When the battery pack is charged for the first time and after prolonged storage, the battery pack will accept a 100% charge after several charge and discharge cycles.

#### B. To Remove Or Install Battery Pack (Fig. A)

Depress the battery pack release button (7) to release and slide the battery pack out from your tool. After recharge, slide it back into your tool. A simple push with slight pressure will be sufficient.

## OPERATION

### 1. ON / OFF Switch (Fig. B)

Depress the ON/OFF switch(8) to start and release it to stop your drill. The on/off switch is fitted with a brake function which stops your chuck immediately when you quickly release the switch. It is also a variable speed switch that delivers higher speed and torque with increased trigger pressure. Speed is controlled by the amount of switch trigger pressure.



**Warning: Do not operate for long periods at low speed because excess heat will be produced internally.**

### 2. Switch Lock

The switch trigger can be locked in the OFF position. This helps to reduce the possibility of accidental starting when not in use. To lock the switch trigger, place the rotation control in the center position.

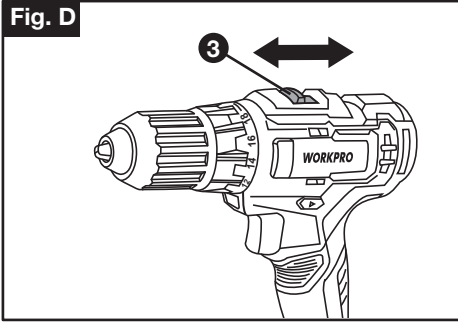
**Fig. D****3. Reversible (Fig. C1, C2)**

For drilling and screw driving use forward rotation (4) marked “◀” (lever is moved to the left). Only use reverse rotation marked “▶” (lever is moved to the right) to remove screws or release a jammed drill bit.

**⚠ WARNING: Never change the direction of rotation when the chuck is rotating, wait until it has stopped!**

**4. Two-speed Gear Control (Fig. D)**

The drill has a two-speed gear control designed for drilling or driving at LOW (mark is 1) or HIGH (mark is 2) speeds. A slide switch is located on top of the drill to select either LOW or HIGH speed. When using the drill in the LOW speed range, the speed will decrease and the drill will have greater power and torque. When using the drill in the HIGH speed range, the speed will increase and the drill will have less power and torque.

**Gear I**

Low speed range: for screw driving or working with large drilling diameter.

**Gear II**

High speed range: for working with small drilling diameter.

**⚠ WARNING: To prevent gear damage, always allow the chuck to come to a complete stop before changing the direction of rotation or the two-speed gear control.**

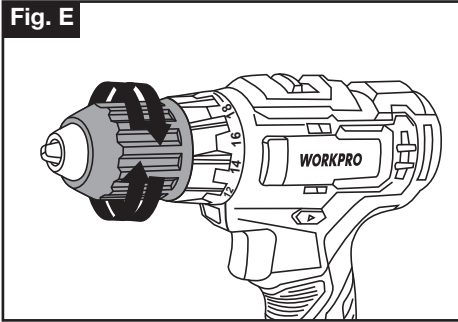
**Fig. E****5. Chuck Adjustment (Fig. E)**

To open the chuck jaws rotate the front section of the chuck. Insert the drill bit between the chuck jaws and rotate the front section in the opposite direction. Ensure the drill bit is in the center of the chuck jaws. Finally, firmly rotate the front chuck section in the opposite directions. Your drill bit is now clamped in the chuck.

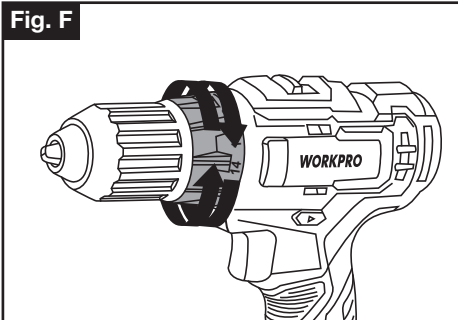
**Fig. F****6. Torque Adjustment (Fig. F)**

(Screw driving force of your drill driver)The torque is adjusted by rotating the torque adjustment ring. The torque is greater when the torque adjustment ring is set on a higher setting. The torque is less when the torque adjustment ring is set on a lower setting.

Make the setting as follows:

1-4	For driving small screws
5-9	For driving screws into soft material
10-13	For driving screws into soft and hard material
14-16	For driving screws into hard wood
17-18	For heavy drilling
	For driving larger screws

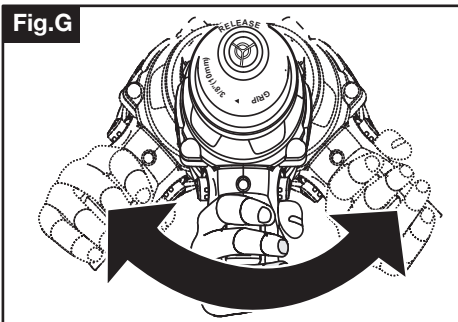
**Fig. G****7. Automatic Spindle Lock (Fig. G)**

The automatic spindle lock allows you to use it as a regular screwdriver. You can give an extra twist to firmly tighten a screw, loosen a very tight screw or continue working when the battery energy has expired. For manual screwdriver purposes, the chuck is automatically locked when the tool is off.

**Fig.H**

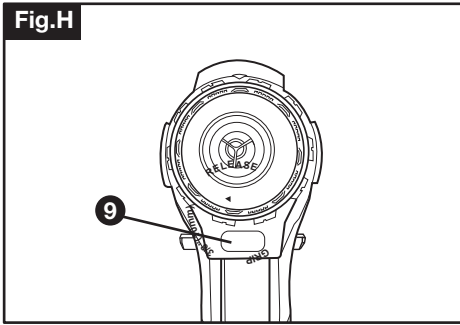

### 8. Using The LED Light (Fig. H)

The LED light allows you to keep a clear view under less illuminated circumstances. To turn on the light simply press the on/off switch. When you release the on/off switch, the light will go out.

### 9. Drilling

When drilling into a hard smooth surface, use a center punch to mark the desired hole location. This will prevent the drill bit from slipping off center as the hole is started. Hold the tool firmly and place the tip of the bit at the point to be drilled. Depress the switch trigger to start the tool. Move the drill bit into the workpiece, applying only enough pressure to keep the bit rotating. Do not force or apply side pressure to elongate a hole.

**⚠ Tungsten carbide drill bits should always be used for concrete and masonry. When drilling in metal, only use HSS drill bits in good condition. Always use a magnetic bit holder (not included) when using short screwdriver bits. When screw-driving, apply a small quantity of liquid soap or similar to the screw threads to ease insertion.**

### 10. Tool Protection System

The tool will automatically stop during operation if the tool and/or battery are placed under one of the following conditions:

- **Overloaded:** The tool is operated in a manner that causes it to draw an abnormally high current. In this situation, release the Trigger Switch on the tool and stop the application that caused the tool to become overloaded. Then pull the Trigger Switch again to restart.
- **Overheated:** Under the condition above, if the tool does not start, the Battery are overheated. In this situation, let the Tool and Battery cool before pulling the Trigger Switch again.
- **Low battery voltage:** The remaining Battery capacity is too low and the tool will not operate. In this situation, remove and recharge the Battery.

## PROBLEM SOLUTION

### 1. Why Does The Drill Not Turn On When You Press The Switch?

The forward/reverse rotation control, which is on top of the trigger, is positioned in the lock function. Unlock the forward/reverse rotation control by putting it into the required rotation position. Push the trigger and the drill will start to rotate. Or if the LED light flashes at the same time you press the Switch, please charge the battery.

### 2. The Drill Stops Before The Screw is Completely Tightened. Why?

Verify the torque position of the torque adjusting ring, you can find the torque-adjusting ring between the chuck and the drill body. Position 1 is the lowest torque (screw driving force) and position 18 is the highest torque (screw driving force). Position  is for drill operation. Regulate the torque adjusting ring to a higher position to reach the best result.

### 3. Reasons for Different Battery Pack Working Times

Charging time problems, as above, and having not used a battery pack for a prolonged time will reduce the battery pack working time. This can be corrected after several charge and discharge operations by charging & working with your drill. Heavy working conditions such as large screws into hard wood will use up the battery pack energy faster than lighter working conditions. Do not re-charge your battery pack below 40° F and above 104° F as this will affect performance.

## MAINTENANCE

- Clean the drill driver using a soft, damp cloth. Do not use detergents or flammable products which may damage the tool.
- Your cordless drill driver does not require regular mechanical maintenance such as greasing the bearings or the rollers.
- Check the state of the charger power cable before each use.

## BATTERY CAPACITY INDICATOR

### Battery capacity indicator

Press the battery capacity indicator switch. The battery capacity indicator shows the charge status of the battery using 4 LEDs.

#### All 4 LEDs are lit:

The battery is fully charged.

#### 3 or 2 or 1 LED(s) are lit:

The battery has an adequate remaining charge.

#### 1 LED blinks:

The battery is empty, recharge the battery.

#### All LEDs blink:

The battery pack is too hot (e.g. due to direct sunshine or prolonged use) or too cold (below 32°F/0°C). Do not use or charge the battery pack. Make sure the battery temperature is between 40°F(4°C) and 104°F(40°C).

## CHARGER INDICATOR

Indicator Status		Explanations and Actions
Red LED	Green LED	
ON	OFF	<b>Ready for use</b> The charger is connected to the mains and is ready for use; there is no battery pack in the charger
OFF	<b>Quick Blink (2Hz)</b>	<b>Low-current safety charging</b> As the battery pack voltage is under 15V, the charger is in gentle charging mode, the charging current is below 0.5A. This can maximize the life of the battery.
OFF	<b>Slow Blink (1Hz)</b>	<b>High-current charging</b> As the battery pack voltage is above 15V, the charger is in quick charge mode, the charging current is at 2.3-2.4A. <b>Important!</b> The actual charging times may vary slightly from the stated charging times depending on the existing battery charge.
OFF	ON	<b>The battery is charged and ready for use.</b> The battery is fully charged and ready to use.. <b>Action:</b> Take the battery pack out of the charger. Disconnect the charger from the mains supply.
<b>Quick Blink (2Hz)</b>	OFF	<b>Fault</b> Charging is no longer possible. The battery pack may be defective. <b>Action:</b> Never charge a defective battery pack. Take the battery pack out of the charger.
<b>Slow Blink (1Hz)</b>	OFF	<b>Temperature fault</b> The battery pack is too hot (e.g. due to direct sunshine/prolonged use) or too cold (below 32°F / 0°C). <b>Action:</b> Remove the battery pack and keep it at room temperature (approx. 68°F / 20°C) for 3 Hours.