

**GENERAL WARNINGS & CAUTIONS:**

The back module (part B.) must be protected from the weather.

**Tools Required (not included):**

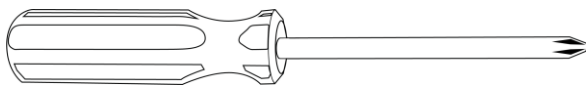

X1 Phillips Screwdriver

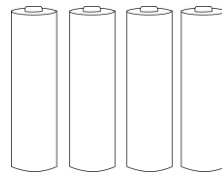

X4 AA Batteries

**Auto-Lock Switch on Part B.:**

On the back module (part B), there is a switch labeled “On-Off” which controls the auto-lock function.

**On** = Automatic lock after 10 seconds. (shortens battery life up to 50%)

**Off** = Does not automatically lock.



For assistance with assembly or installation, parts and customer service, call:  
1-800-355-0157 (English & Spanish)  
9am – 5pm PST Mon. – Fri.  
North America

**Battery Precautions**

- Do not mix old with new batteries.
- Do not use rechargeable batteries.
- Remove batteries from product when storing for extended periods of time.
- Do not dispose of batteries in fire as they may explode. Please follow your local battery disposal procedure.
- Do not puncture batteries. Electrolyte leakage from the batteries is corrosive and can cause serious harm to the eyes or skin. If swallowed, the electrolyte can be toxic.
- Do not allow conductive materials such as jewelry or metal tools to make contact with the batteries which may cause a short circuit. With a short circuit, the batteries and conductive material can become extremely hot and cause burns.

**Register Your Product**

- Although we hope you never have to deal with a warranty claim during the use of our product, you should submit a product registration to validate the warranty. This keeps it on record with us so you don't have to save a receipt or record of any kind. Just give us a call and we will take care of you.
- Register at [www.milocks.com](http://www.milocks.com)

# 1. Adjust Latch Backset

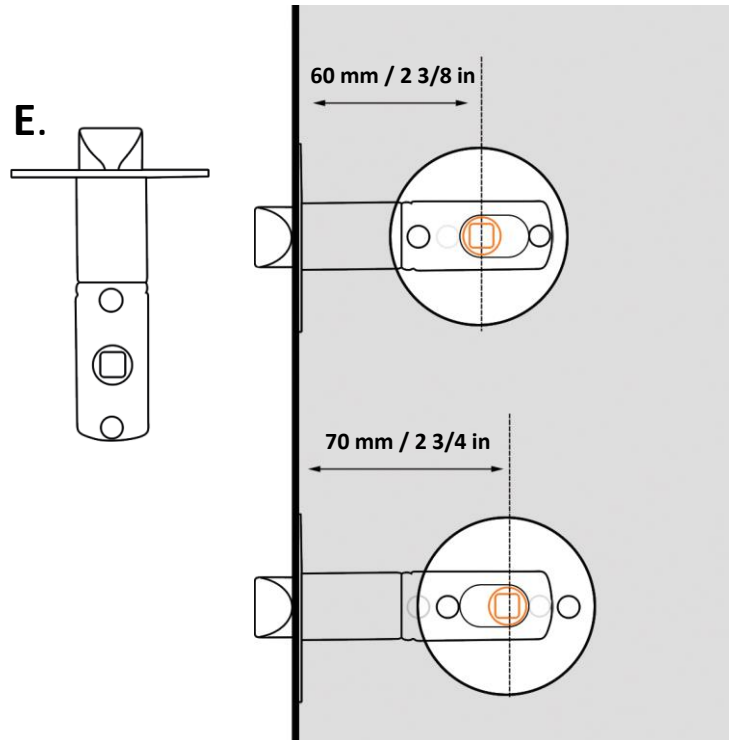

# 4. Fasten Back Mounting Plate

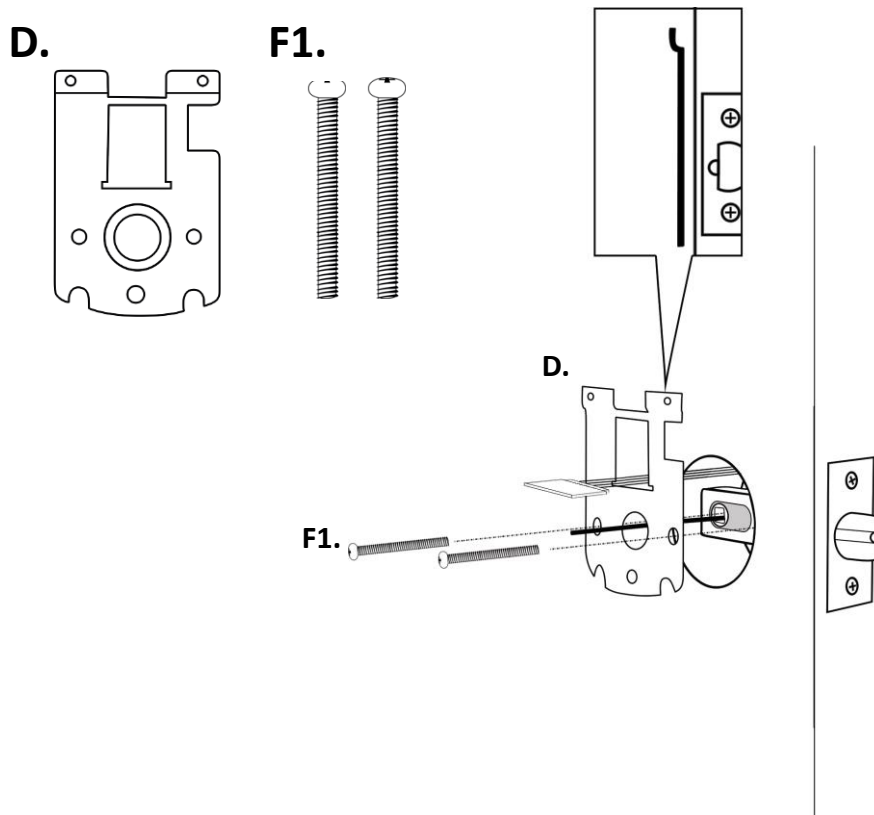

## 2. Install Door Latch

F3.

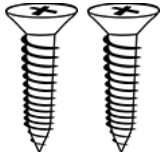

F3.

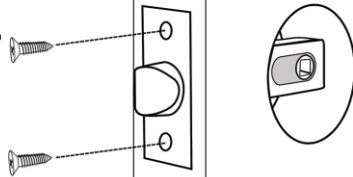

## 5. Mount & Fasten Back Module

B.

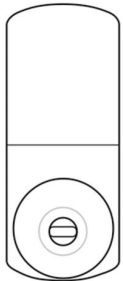

F2.



B.

4x  
AA

F2.

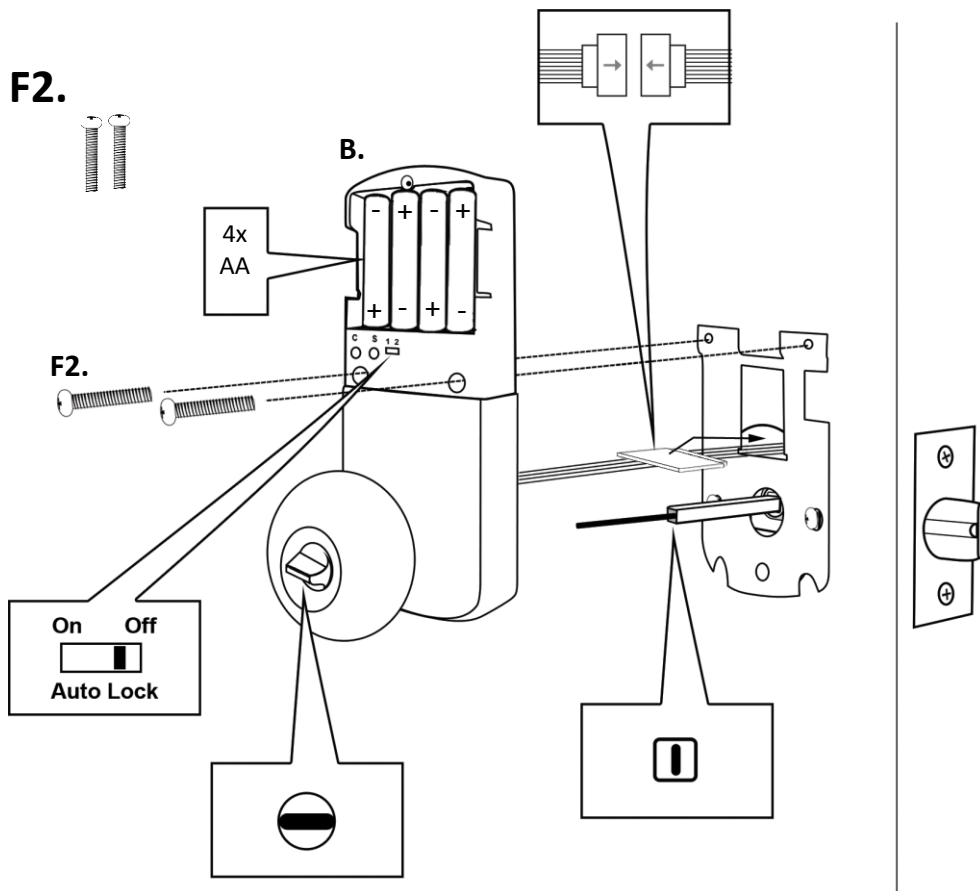

### 3. Mount Front Module

A.

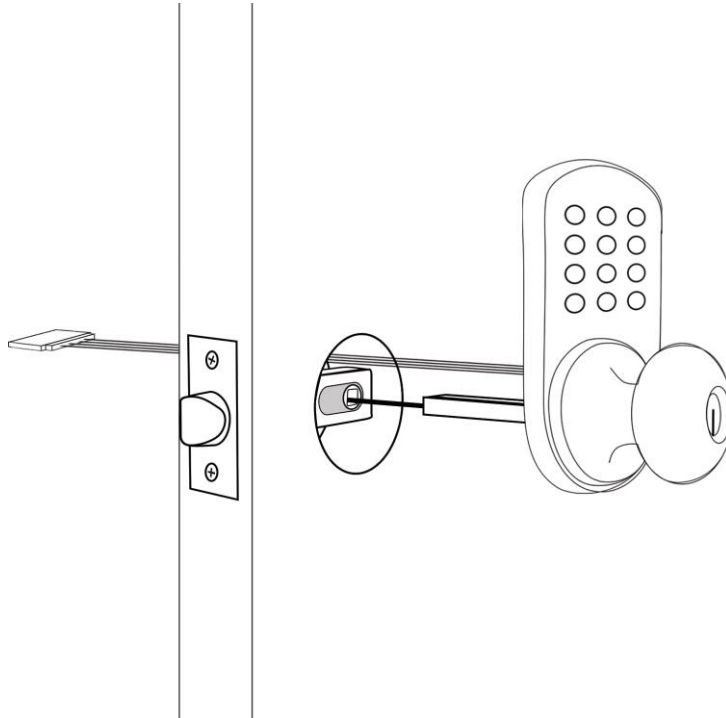
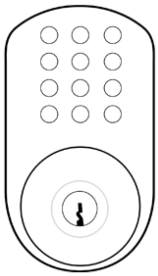

### 6. Install Battery Cover

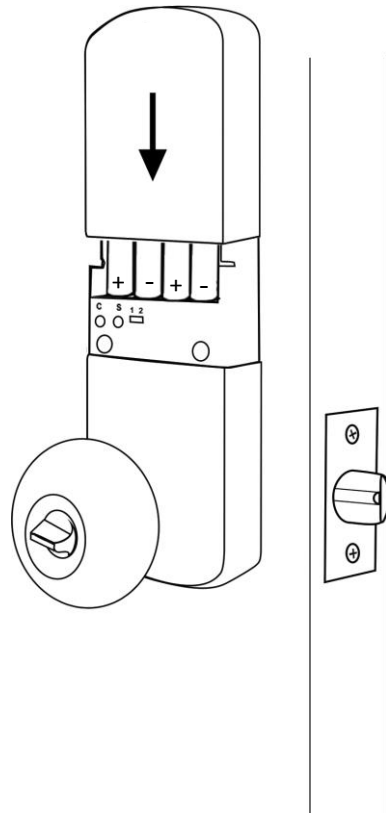

# KEYPAD PROGRAMMING

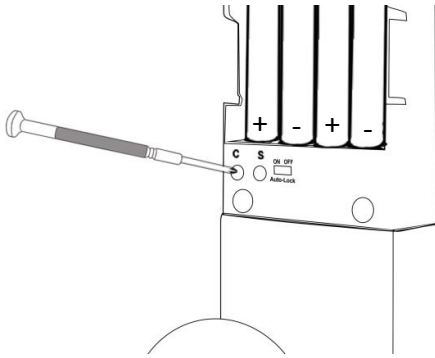

## Delete All Codes *(Recommended for initial set up):*

Press and hold C button and wait for a series of confirmation beeps (continuous beeping). You will have to hold the C button for about 10-15 seconds.

## Add a Code

Press the "S" button once

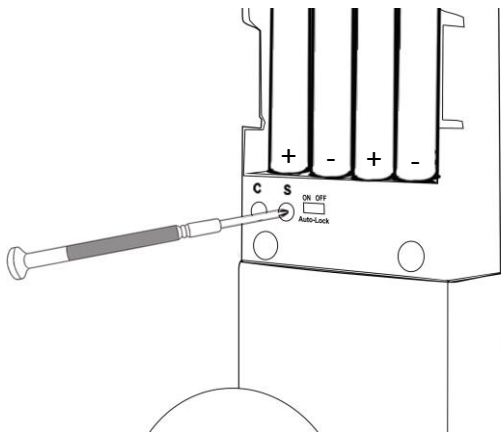

Within 5 sec.



Enter a 2-8 digit passcode followed by the unlock button

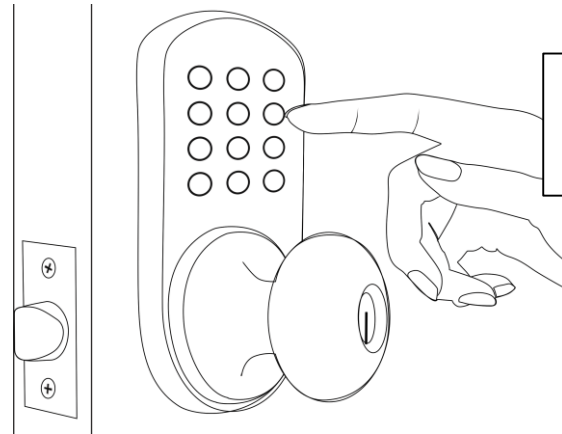

2 Beeps = Success  
3 Beeps = Try Again  
0 Beeps = Go to  
Troubleshooting

## Delete a Code

Press the "C" button once

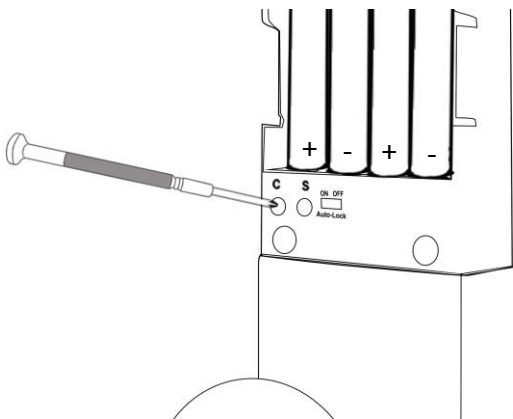

Within 5 sec.



Enter the code you wish to delete followed by the unlock button

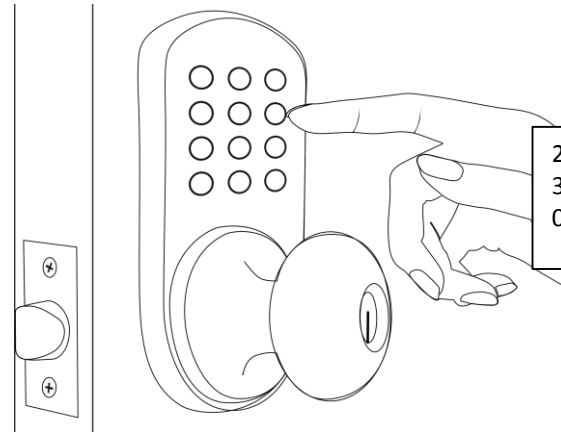

2 Beeps = Success  
3 Beeps = Try Again  
0 Beeps = Go to  
Troubleshooting

### OPERATING INSTRUCTIONS:

TO LOCK: Press the LOCK button once

TO UNLOCK: Enter code followed by the UNLOCK button

TO LIGHT KEYPAD: Press the "Mi" button once

AUTO-LOCK Switch: ON (Locks automatically after 10 sec.)



---

# TROUBLESHOOTING

---

## Low Batteries (Most Common Issue):

If the lock produces a longer set of rapid beeps and either locks or does not lock the door, you have low batteries. To avoid any difficulties during set up, make sure you are using brand new AA alkaline batteries. Using a battery tester is not recommended.

## Loose Keypad Connection:

If not connected securely, the keypad wire harness connection may come loose and cause some of the numbers to operate inconsistently. To confirm your door lock issue is not being caused by a loose keypad connection, press every number on the keypad and confirm every button beeps when pressed.

If some of the numbers are not beeping, remove the back module (*part B*) and inspect the wires for any pinches or tears. Make sure to check the wires coming from the keypad as well. Disconnect the wire harness and make sure the pins in the male connection are not bent out of alignment. Reconnect the wires and confirm every button on the keypad beeps when pressed.

If you are still having keypad issues after following our troubleshooting guide, call us for a replacement under warranty.

## Function Test:

If a passcode has not been successfully programmed, the lock will not operate using the keypad. Lets check if a passcode has been successfully programmed in the memory:

1. Unlock the knob and open the door. Make sure you keep the door open while troubleshooting.
2. Press the LOCK button on the keypad 1 time and listen to the beeps:
  - If the lock beeps 3 times and does not lock, it does not have a passcode set in its memory. Refer to the programming page for information on adding a passcode.
  - If the lock produces a longer set of rapid beeps and either locks or does not lock the door, you have low batteries. Replace the batteries with a set of 4 premium "AA" alkaline batteries.
  - If the lock beeps 2 times then locks, it has at least 1 passcode stored in its memory and is operating correctly.

**If you are unable to get your lock to work  
please give us a call during business hours.**

US Live Tech Support: 1-800-355-0157 M-F 9am - 5pm PST (English & Spanish)

Warranty shipments are always shipped promptly.

## WARRANTY

MiProducts Corporation warrants to the original residential user of this product that it will be free from defects in materials and workmanship, under normal use, for 1 year from the date of purchase. User must provide a copy of original purchase receipt. This warranty does not cover abuse or misused products or products used in commercial applications. All mechanical components carry a limited warranty, for a period of 25 years from the date of purchase. The finish of the exterior of this lock carries a limited warranty of the lifetime of the unit against deterioration due to normal weather conditions. This warranty does not apply to locks that have been improperly installed, modified, put to a use other than designed, or subjected to acts of God (such as floods, lightning, earthquakes, etc.) This warranty is limited to repairing or replacing of this lock only at MiProducts Corporation's sole discretion. MiProducts Corporation will NOT be liable for the cost of installing, removing, nor reinstalling this product, nor direct, indirect, or consequential damages to persons or property resulting from the use of this product. This warranty only covers the cost of replacement parts, it does not cover shipping & handling fees.

To implement this warranty please give us a call during business hours at 1-800-355-0157, or visit [www.milocks.com](http://www.milocks.com).