

# Vacuum Sealer

User's manual

EN



**SENCOR®**

SVS 2010WH

**Translation of the original manual**

Before first use, please read all instructions contained in this user manual carefully, even if you are already familiar with using similar products. Only use this product in accordance with the instructions described in the user manual. Keep the user's manual in a safe place where it can be easily retrieved for future use.

Save the original packaging, material, warranty card and proof of purchase receipt, at least for the duration of the warranty policy. If you need to ship this product, pack it in the original cardboard box to ensure maximum protection during shipping or transport (e.g., when moving or when you need to send this product for repair).

EN-1

**CONTENTS**

IMPORTANT SAFETY INSTRUCTIONS .....	3
USER'S MANUAL .....	6
DESCRIPTION OF THE APPLIANCE .....	6
DESCRIPTION OF THE CONTROL PANEL .....	6
WHAT IS THE PURPOSE OF A VACUUM SEALER .....	6
VACUUM SEALER BAGS AND ROLLS .....	7
USING THE VACUUM SEALER .....	7
ADVICE AND RECOMMENDATIONS .....	8
FOOD STORAGE TIME .....	9
CLEANING AND MAINTENANCE .....	9
TECHNICAL SPECIFICATIONS .....	10
INSTRUCTIONS AND INFORMATION REGARDING THE DISPOSAL OF USED PACKAGING MATERIALS .....	12
DISPOSAL OF USED ELECTRICAL AND ELECTRONIC EQUIPMENT .....	12

## **IMPORTANT SAFETY INSTRUCTIONS READ CAREFULLY AND STORE FOR FUTURE USE.**

### **General warnings**

- This appliance may be used by children 8 years of age and older and by persons with physical or mental impairments or by inexperienced persons, if they are properly supervised or have been informed about how to use the product in a safe manner and understand the potential dangers.
- Children must not play with the appliance. Cleaning and maintenance performed by the user must not be performed by unsupervised children.
- In the event that the power cord is damaged, have it repaired at a professional service centre to prevent causing a dangerous situation. It is forbidden to use the appliance if it has a damaged power cord.

### **Electrical safety**

- Before connecting this appliance to a power socket, make sure that the voltage stated on its rating label corresponds to the voltage in your power socket.
- Connect the appliance only to a properly grounded socket. Do not use an extension cord.
- Fully unwind the power cord before using it.
- Do not connect and disconnect the power cord to and from the power socket with wet hands.
- Ensure that the power plug contacts do not come into contact with water or any other liquid. If precisely this happens, carefully dry the power plug before using it again.
- Do not disconnect the appliance from the power socket by pulling on the power cord. This could damage the power cord or the power socket. Disconnect the power cord from the power socket by pulling on the plug.
- Do not place heavy items on the power cord. Make sure the power cord does not hang over the edge of a table or that it is not touching a hot surface or sharp objects.
- Do not wind the power cord around the appliance.
- Always turn off the appliance and disconnect it from the power socket when not using it, when leaving it without supervision and before cleaning, maintenance or storage.

- To avoid the danger of injury by electrical shock, do not repair the appliance yourself or make any adjustments to it. Have all repairs or adjustments of the appliance performed at an authorised service centre. Tampering with the appliance during the warranty period may void the warranty.
- To prevent the risk of injury by electrical shock, never submerge the appliance and its power cord in water or any other liquid, or wash these parts under running water.
- In the event that the appliance falls into water, under no condition reach for it, rather, immediately disconnect the power cord from the power socket. Never use an appliance that was submerged in water. Hand it over to an authorised service centre for inspection.
- Always turn off the appliance and disconnect it from the power socket when you have finished using it.

### Safety during use

- This appliance is intended for home use exclusively. Do not use this appliance for commercial purposes.
- Do not use the appliance in an industrial environment or outdoors. Do not use it for any other purposes than those intended.
- This appliance is not intended to be operated using an external timer switch or a remote control system that would enable this appliance to be turned on automatically.
- Use the appliance and its accessories in accordance with the instructions contained in this user's manual.
- Only use the appliance with the original accessories that came with it.
- Do not place the appliance on an electric or gas stove or in its vicinity, on a kitchen sink drainboard, on the edge of a table, on window sills or on unstable surfaces. Always place it on a stable, even and dry surface.
- Do not place the appliance in the vicinity of wash basins or sinks or near heaters, open fires or other sources of heat.
- Only use the appliance when installed in its working position and located at a sufficient distance from flammable surface such as curtains, drapes, etc.
- Do not expose the appliance and its accessories to the outdoor environment, extreme temperatures, direct sunlight, excessive humidity or excessively dusty environments.
- Do not use the appliance if it has fallen on the floor, if it was submerged in water, if it is not functioning correctly or if it is damaged in any other way. Before every use, check the appliance for damage.
- Only use quality vacuum sealer bags and rolls intended for vacuum sealers.
- Make sure that water or any other liquid does not enter into the air exhaust inlet.
- The appliance heats up during operation and remains hot after operation as a result of residual heat. Avoid contact with hot surfaces.
- The appliance is equipped with a thermal fuse that turns it off upon overheating. In the event that such a situation occurs, disconnect the appliance from the power socket and allow it to cool down. Then you may continue using it.
- Do not touch the seal immediately after it is created. There is risk of burns.
- Do not touch the gasket strip, rubber strips or the foam gasket as this could damage these parts. These parts heat up when the permanent seal is created. Do not touch these parts immediately after the seal is created.
- Do not turn on the appliance when it is empty. Incorrect use of the appliance may negatively affect its lifetime. Do not leave a running appliance without supervision.
- A rest period of at least 40 seconds should be implemented between the sealing cycles to allow the appliance to cool down. Leave the lid open during the rest period. The maximum operating time is 15 minutes. Then allow it to cool down for approximately 30 minutes.
- Do not perform any maintenance on the appliance apart from the cleaning procedure described in chapter Cleaning and maintenance.
- In order to prevent a hazardous situation arising, do not repair the appliance yourself or modify it in any way. Have all repairs performed at an authorised service centre. By tampering with the appliance, you risk voiding your legal rights arising from unsatisfactory performance or quality warranty.
- Store the appliance in a dry environment.

# Vacuum Sealer

SVS 2010WH

EN

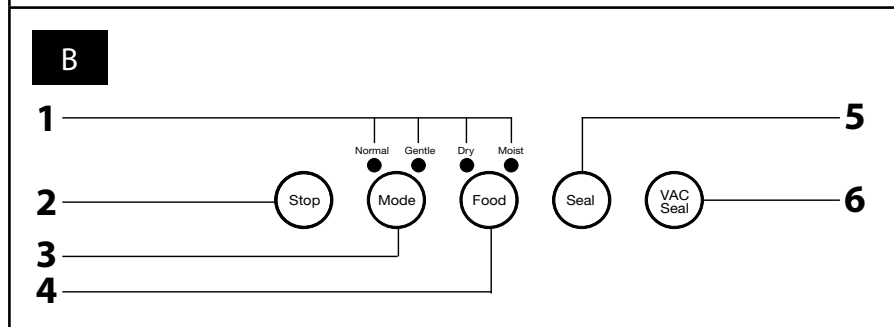
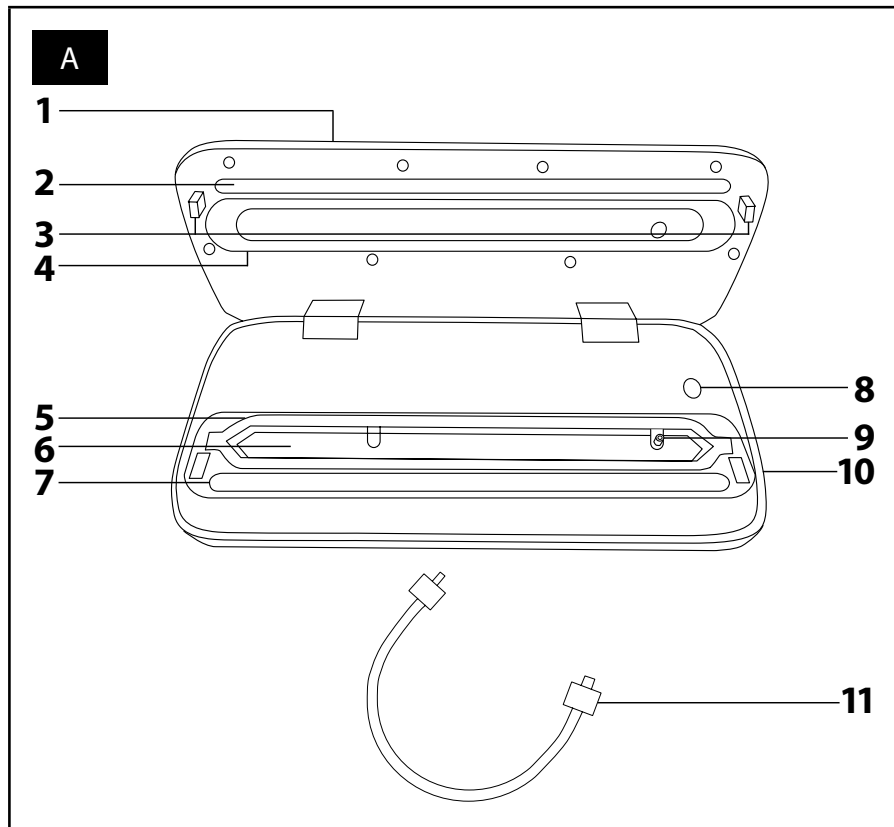

EN-5

## USER'S MANUAL

- Prior to using this appliance, please read the user's manual thoroughly, even in cases, when one has already familiarised themselves with previous use of similar types of appliances. Only use the appliance in the manner described in this user's manual. Keep this user's manual in a safe place where it can be easily retrieved for future reference.
- We recommend saving the original cardboard box, packaging material, purchase receipt and responsibility statement of the vendor or warranty card for at least the duration of the legal liability for unsatisfactory performance or quality. In the event of transportation, we recommend that you pack the appliance in the original box from the manufacturer.

## DESCRIPTION OF THE APPLIANCE

- A1** Tilt-out lid
- A2** Sealing strip  
Creates a strong seal by melting.
- A3** Latch  
serves to lock the lid in the closed position.
- A4** Top gasket
- A5** Bottom gasket
- A6** Vacuum chamber
- A7** Rubber strip
- A8** Button for turning air suction from an external vacuum container on and off.
- A9** Air suction inlet
- A10** Latch release button  
is located on both sides of the vacuum sealer.
- A11** Hose for sucking air out of external vacuum containers.



### Note:

The appliance is supplied together with 5 vacuum sealer bags from PA/PE material with dimensions of 20 × 30 cm and 1 vacuum sealer roll from PA/PE material with dimensions 20 × 200 cm.

## DESCRIPTION OF THE CONTROL PANEL

- B1** Operating mode setting LED indicators
- B2** STOP touch button  
for ending operation
- B3** MODE touch button  
for setting the operating mode:  
– NORMAL (standard) for standard vacuum sealing,  
– GENTLE for gentle vacuum sealing of loose foodstuffs.
- B4** FOOD touch button for setting the operating mode:
- DRY for vacuum sealing dry foodstuffs,
  - MOIST for vacuum sealing higher moisture foodstuffs.
- B5** SEAL touch button  
for making a strong seal  
with LED indicator signalling the sealing time
- B6** VAC/SEAL touch button for creating a vacuum and making a strong seal  
with LED indicator signalling the vacuum sealing time



### Note:

Certain models are equipped only with buttons **B2**, **B5** and **B6**. The appearance of touch buttons and indicators may differ depending on the model.

## WHAT IS THE PURPOSE OF A VACUUM SEALER

- When stored in the normal manner, foodstuffs lose their flavour, aroma and nutrients. Bacteria multiply, moulds form in these foodstuffs, which leads to their spoilage. The vacuum sealer enables one to create a vacuum package, and the freshness of foodstuffs can be extended by up to 5 times compared to standard storage methods without requiring any preservation or other chemicals. Likewise, vacuum sealing may also shorten marinating times, which usually take several hours, down to only 20 minutes.
- Vacuum sealing can also be used to protect various items against the entry of water or insects.

## VACUUM SEALER BAGS AND ROLLS

- The vacuum sealer bags and rolls supplied with this appliance consist of two layers that provide effective protection against the entry of air and moisture. This enables one to store foodstuffs fresher for longer. The inner layer is from PE material. The outer layer is made from PA material. In these vacuum sealer bags, it is possible to heat foodstuffs in a microwave oven or boil in water.
- Additional vacuum sealer rolls can be purchased under part number SVX 300CL.

## USING THE VACUUM SEALER

- Connect the power cord to a power socket and tilt open the lid **A1**. When the power cord is connected to a power socket, the indicators **B1** will be lit. The default operating mode setting is NORMAL and DRY.

### 1. SEALING FUNCTION

- 1.1 Fill the vacuum sealer bag with foodstuffs up to max.  $\frac{3}{4}$  of its volume. Insert the bag with the open side into the vacuum sealer so that its edges extend past the rubber strip **A7** by at least 1.5 cm. Check that the place where the seal will be made is clean, dry and free of creases. Push the lid **A1** down firmly until an audible click is heard.
- 1.2 Press the SEAL button **B5**. The LED indicator of button **B5** will be lit and a firm seal will be made under the sealing strip **A2**. The sealing process takes approximately 6 to 10 seconds. As soon as the sealing process is finished, the LED indicator of button **B5** will turn off. To release the lid **A1**, press buttons **A10**. Tilt open the lid **A1**, remove the bag and check the strength of the seal.



**Note:**

When using the vacuum sealer role, it is necessary to first make a seal that will form the bottom of the vacuum sealer bag.

The sealing process can be ended at any time by pressing the STOP button **B2**.

### 2. VACUUM WITH SEALING FUNCTION

- 2.1 Fill the vacuum sealer bag with foodstuffs up to max.  $\frac{3}{4}$  of its volume. Insert the bag with the open side into the vacuum sealer so that its edge is located inside the vacuum chamber **A6**. The bag must not cover the air suction inlet **A9**.
- 2.2 Check that the place where the seal will be made is clean, dry and free of creases. Push the lid **A1** down firmly until an audible click is heard.
- 2.3 Depending on the type of foodstuffs that are placed in the bag, set the operating mode using buttons **B3** and **B4**. Press the VAC/SEAL button **B6**. The LED indicator of button **B6** will be lit and the air suction process will start automatically. When a complete vacuum is achieved, the air suction process will stop automatically and the LED indicator of button **B6** will turn off. The vacuum sealer will switch to the sealing mode. This is indicated by the LED indicator of the SEAL button **B5** being lit. A strong seal will be made under the sealing strip **A2**. The whole process takes approximately 10 to 20 seconds. As soon as the sealing process is finished, the LED indicator of button **B5** will turn off. To release the lid **A1**, press buttons **A10**. Tilt open the lid **A1**, remove the bag and check the strength of the seal.



**Note:**

When using the vacuum sealer role, it is necessary to first make a seal that will form the bottom of the vacuum sealer bag.

In the event that an insufficient vacuum is being created, push down on the lid **A1** for a short time during the vacuuming process.

The air suction or sealing process can be ended at any time by pressing the STOP button **B2**.

In the event that you do not wish a complete vacuum to be created inside the bag, you may manually switch to the sealing mode by pressing the SEAL button **B5**.

**Attention:**

Allow hot foodstuffs to cool down before creating a vacuum package.



### 3. AIR SUCTION FROM AN EXTERNAL VACUUM CONTAINER FUNCTION

- 3.1 Place foodstuffs into the vacuum container (not included). Close the container with its lid. Connect the wider connector on hose **A11** to the air suction inlet **A9**. Connect the narrower connector to the hole in the lid of the container.
- 3.2 Press the button for turning on air suction from an external container **A8**. When the air suction process is complete, the appliance will turn off automatically.
- 3.3 First disconnect the connector from the hole in the lid and only then disconnect the connector from the air suction inlet **A9**.
- 3.4 To extend the storage life of the foodstuffs in the vacuum container, place this container into a refrigerator.
- 3.5 Before removing the foodstuffs from the container, first press the button on the lid to release the vacuum. Only then open the lid.
- 3.6 Remove the lid from the vacuum container before heating in a microwave.

**Note:**

The air suction process can be ended at any time by again pressing button **A8**.

- When a bag is melted, it is necessary to wait 5 minutes for the sealing strip **A2** to cool down.
- A rest period of at least 40 seconds should be maintained between the sealing cycles to allow the appliance to cool down. Leave the lid **A1** open during the rest period. The maximum operating time is 15 minutes. Then allow it to cool down for approximately 30 minutes.
- When you have finished, disconnect the power cord from the power socket and allow the appliance to cool down. Clean out the appliance after each use according to the instructions in chapter Cleaning and maintenance.

### ADVICE AND RECOMMENDATIONS

- Do not overfill the bags. Leave sufficient free space inside them so that you can insert the open side into the vacuum sealer and to easily close its lid **A1**. Fill the vacuum containers so that there is at least 2.5 cm of free space under the edge.
- Make sure that the open side of the bag that is inserted into the vacuum sealer is clean, dry and free of creases. Moisture or creases may result in a strong seal not being created or a seal not being created at all.
- Vacuum sealed packaging cannot substitute for storing foodstuffs in a refrigerator or freezer. Place foodstuffs contained in a vacuum package that spoil quickly into a refrigerator or freezer. This will extend their storage life.
- If you wish to vacuum seal items of larger dimensions, straighten the open side of the bag before inserting it into the vacuum sealer.
- We recommend wrapping items with sharp edges or dry pasta in paper tissue before placing them into a vacuum sealer bag. This will protect it against damage.
- If you are not certain that the seal is sufficiently strong, seal the bag once more to make sure.
- The sides of the original vacuum sealer bags are sealed along their entire length all the way to the edges. Do not attempt to adjust them, otherwise the vacuum may be compromised.
- Bag sealing problems may arise for foodstuffs with a higher moisture content. In the event that such a situation arises, remove a part of the foodstuffs, thoroughly clean the edge of the bag and attempt to seal it again.
- The tightness of the vacuum sealer bag can be verified by submerging it in water. Bubbles will come out of the bag from the unsealed location.
- Foodstuffs will spoil unless a complete vacuum is created in the bag. Spoiled foodstuffs must be disposed of.
- Do not use vacuum sealer bags repeatedly if they contained raw meat, fish, greasy foodstuffs, etc. or if you heated foodstuffs in them in a microwave oven or in boiling water.

## FOOD STORAGE TIME

### REFRIGERATOR, TEMPERATURE 5 °C (±2 °C)

Food type	Not vacuum sealed	Vacuum sealed
Red meat	3–4 days	8–9 days
White meat	2–3 days	6–8 days
Fish	1–3 days	4–5 days
Cooked meat	3–5 days	10–15 days
Soft cheese	5–7 days	20 days
Semi-hard and hard cheese	15–20 days	60 days
Fruit	5–7 days	14–20 days
Vegetables	1–3 days	7–10 days
Soups	2–3 days	8–10 days
Cooked pasta/rice	2–3 days	6–8 days
Cream desserts	2–3 days	8 days

### ROOM TEMPERATURE 25 °C (±2 °C)

Food type	Not vacuum sealed	Vacuum sealed
Fresh bread	1–2 days	8–10 days
Biscuits	4–6 months	12 months
Pasta/rice (in raw state)	5–6 months	12 months
Flour	4–6 months	12 months
Dried fruit	3–4 months	12 months
Ground coffee	2–3 months	12 months
Loose tea	5–6 months	12 months

### FREEZER, TEMPERATURE –18 °C (±2 °C)

Food type	Not vacuum sealed	Vacuum sealed
Meat	4–6 months	15–20 months
Fish	3–4 months	10–12 months
Vegetables	8–10 months	8–24 months

## CLEANING AND MAINTENANCE

- Before cleaning, disconnect the power cord from the power socket and allow the appliance to cool down.
- Remove any remains or liquids from the vacuum chamber **A6**. Then clean it with a lightly dampened cloth and thoroughly wipe dry.
- To clean the external surfaces, use a cloth lightly dipped in water with neutral kitchen detergent. Then wipe everything so that it is thoroughly dry.
- For cleaning, never use steel wool, abrasive cleaning products, solvents, etc.



### Attention:

Do not submerge the appliance or its power cord in water or any other liquids.

**TECHNICAL SPECIFICATIONS**

Rated voltage range	220–240 V
Rated frequency	50 Hz
Rated power input	110 W
Electrical shock protection class	II
Noise level	75 dB(A)
Maximum vacuum pressure	–0.8 bar
Compressor power	12l/min
Maximum roll and bag width	30 cm

The declared noise emission level of the appliance is 75 dB(A), which represents a level A of acoustic power with respect to a reference acoustic power of 1 pW.

Explanation of technical terminology

Safety class for electrical shock protection:

Class II – Electrical shock protection is provided by double or heavy-duty insulation.

We reserve the right to change text and technical specifications.

# Vacuum Sealer

SVS 2010WH

EN

EN-11

## INSTRUCTIONS AND INFORMATION REGARDING THE DISPOSAL OF USED PACKAGING MATERIALS

Dispose of used packaging material at a site designated for waste in your municipality.

## DISPOSAL OF USED ELECTRICAL AND ELECTRONIC EQUIPMENT



This symbol on products or original documents means that used electric or electronic products must not be added to ordinary municipal waste. For proper disposal, renewal and recycling hand over these appliances to determined collection points. Alternatively, in some European Union states or other European countries you may return your appliances to the local retailer when buying an equivalent new appliance.

Correct disposal of this product helps save valuable natural resources and prevents potential negative effects on the environment and human health, which could result from improper waste disposal. Ask your local authorities or collection facility for more details.

In accordance with national regulations penalties may be imposed for the incorrect disposal of this type of waste.

### **For business entities in European Union states**

If you want to dispose of electric or electronic appliances, ask your retailer or supplier for the necessary information.

### **Disposal in other countries outside the European Union.**

This symbol is valid in the European Union. If you wish to dispose of this product, request the necessary information about the correct disposal method from the local council or from your retailer.



This product meets all the basic requirements of EU directives related to it.