

Owner's Manual

UPS Systems

Models: SMART1524ET and SMART1548ET
(Series Number: AG-88E6, AG-88E5)

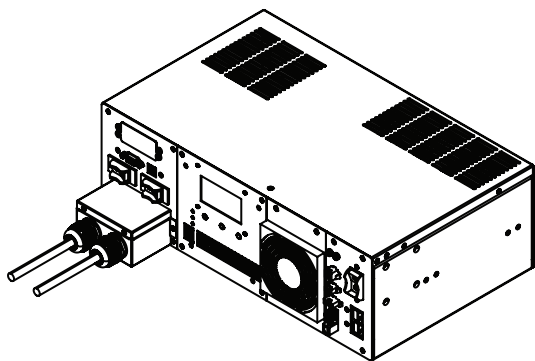

Este manual esta disponible en español en la página de Tripp Lite: tripplite.com

Ce manuel est disponible en français sur le site Web de Tripp Lite : tripplite.com

WARRANTY REGISTRATION

Register your product today and be automatically entered to win an ISOBAR® surge protector in our monthly drawing!

tripplite.com/warranty



Manufacturing
Excellence.

tripplite.com/support

Copyright © 2024 Tripp Lite. All rights reserved.

Table of Contents

Important Safety Instructions	3	Operation	15
UPS Location Warnings	3	Basic On/Off and Manual	15
UPS Connection Warnings	3	UPS Test Verification	
Equipment Connection Warnings	3	Operating the LCD / LED Control Panel	17
Battery Warnings	4	LCD Menu Tree	18
UPS and Battery Recycling	4	LCD Menu Overview	18
Introduction	5	LCD Menu Explanations	19
System Architecture	5	RS-232 / USB Communications Interface	26
Package Contents	6	HyperTerminal Set Up	26
Optional Accessories	6	RS-232 / USB Main Menu	30
User Supplied Items	6	RS-232 / USB Menu Tree	31
Features	7	Menu Overview	31
UPS Front Panel	7	Troubleshooting	45
Mounting	10	Alarm and Fault Messaging	45
2-Post Rack Mounting the UPS	10	UPS Alarm Messages	46
4-Post Rack Mounting the UPS	10	Battery Backup Time	49
Desktop Mounting the UPS	11	Internal Fan Relacement	51
Wiring the UPS	12	Fan Replacement	51
AC Input and Output Wiring	12	Fan Filter Replacement	53
External Battery Connections (Deep-Cycle Lead-Acid Batteries Only)	13	Storage and Service	54
Additional Wiring Connections (Optional)	14	Product Registration	54
		Regulatory Compliance	55

Important Safety Instructions

SAVE THESE INSTRUCTIONS

This manual contains instructions and warnings that should be followed during the installation, operation, maintenance and storage of the UPS and batteries. Failure to heed these warnings may affect the warranty.

UPS Location Warnings

- Install your UPS within an enclosure or location that protects against excessive moisture, conductive contaminants, dust or direct sunlight.
- For best UPS performance, maintain site temperature between -40°F and 176°F (-40°C and 80°C).
- Leave adequate space around all sides of the UPS for proper ventilation.
- Only set the UPS upright on a sturdy flat surface. Do not block fans or ventilation holes, as this will seriously inhibit the unit's internal cooling and cause product damage not covered under warranty.

UPS Connection Warnings

- Hardwire the UPS directly to a properly grounded power source.
- If the UPS receives power from a motor-powered AC generator, the generator must provide clean, filtered, computer-grade output.
- The mains power that supplies power to the UPS should be easily accessible and located near the UPS.

Equipment Connection Warnings



Install in accordance with National Electrical Code standards ANSI/NFPA 70 and Canadian Electrical Code, Part I, C22.1.

Short-circuit backup protection and overcurrent protection is provided by the building installation.

To reduce the risk of fire, connect only to a circuit provided with branch circuit overcurrent protection in accordance with the National Electrical Code, ANSI/NFPA 70 and the Canadian Electrical Code, Part I, C22.1. Be sure to provide a disconnect device in the end use installation.

- Use of this equipment in life support applications where failure of this equipment can reasonably be expected to cause the failure of the life support equipment or to significantly affect its safety or effectiveness is not recommended.
- Do not connect surge protectors or extension cords to the output of your UPS. This might damage the UPS and may affect the surge protector and UPS warranties.

Important Safety Instructions

- Connect the UPS to a power source that is adequately protected against excess currents, short circuits and earth faults as part of the building installation.

Battery Warnings

- Batteries can present a risk of electrical shock and burn from high short-circuit current. Observe proper precautions. There are no user-serviceable parts inside the UPS. Do not open the UPS. Do not open batteries. Do not short or bridge the battery terminals with any object. Do not dispose of batteries in a fire. The batteries may explode. Released material is harmful to the skin and eyes. It may be toxic. Unplug and turn off the UPS before performing battery replacement. Use tools with insulated handles. Battery replacement should be performed only by authorized service personnel using the same number and type of batteries (sealed lead-acid).



CAUTION: A battery can present a risk of electrical shock and high short-circuit current. Contact with any part of a grounded battery can result in electrical shock. The following precautions should be observed when working on batteries:

- Remove watches, rings or other metal objects.
- Use tools with insulated handles.
- Wear rubber gloves and boots.
- Do not lay tools or metal parts on top of batteries.
- Disconnect charging source and load prior to installing or maintaining the battery.
- Remove battery grounds during installation and maintenance to reduce likelihood of shock.
- Remove the connection from ground if any part of the battery is determined to be grounded.

UPS and Battery Recycling



Pb

Tripp Lite products use sealed lead-acid batteries, which are highly recyclable.

Call Tripp Lite at 773.869.1234 or visit tripplite.com/support/recycling-program for more information on recycling the batteries or any other Tripp Lite product. Please refer to local codes for disposal requirements.

Introduction

Tripp Lite's SMART1524ET and SMART1548ET line-interactive UPS Systems offer a wide operating temperature range and provide constant and reliable backup power to critical equipment in harsh environments, including outdoor equipment. The UPS systems distribute utility power to connected equipment when input power is available and is within valid UPS voltage limits. Automatic Voltage Regulation (AVR) is available to stabilize output voltage to protected equipment. The UPS will switch to battery backup power during utility power outages and extreme voltage fluctuations to keep connected equipment running without interruption.

The maximum output capacity of the UPS system is temperature-dependent:

1600W: -40°F to 131°F (-40°C to 55°C)

1200W: 131°F to 167°F (55°C to 75°C)

1000W: 167°F to 176°F (75°C to 80°C).

System Architecture

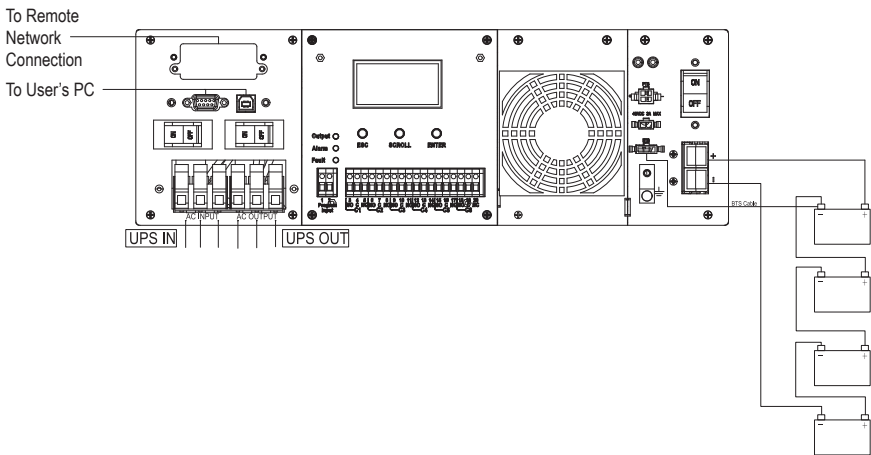

Note: The 48V configuration is shown for SMART1548ET.

Package Contents

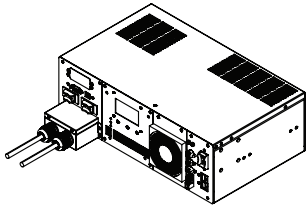

UPS System

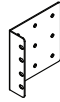

Rack-Mount Brackets (2)

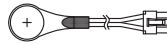

Battery Temperature Sensor Cable (1)



Owner's Manual



External Battery Connection Kit (1)



AC Hardwire Strain Reliefs (2)



USB Cable (1)

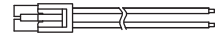

External Fan Power Adapter Cable (1)



M4 Screws (8)



M6 Screws (4)



External Battery DC Connector Cable Assembly Instruction Sheet

Note: If the listed parts on your package do not match the items you received, or if any items appear damaged, please immediately notify your carrier agent and the supplier who prepared your shipment.

Optional Accessories

- WEBCARDLXMINI: Network interface card for SNMP/Web control and monitoring

User Supplied Items

- Wide Temperature Range 48V DC (SMART1548ET) or 24 VDC (SMART1524ET) Lead-Acid Battery System with included ANDERSON PA75 DC Connection kit.
 - The UPS requires a user-supplied battery system that connects to the UPS via ANDERSON PA75 DC Connection Kit.
 - The batteries used must be rechargeable, deep-cycle lead-acid type.
 - Select batteries that meet your high- and low-temperature requirements for reliable operation.
 - The recommended battery cable gauges are 6 AWG for the SMART1524ET and 8 AWG for the SMART1548ET, with a maximum recommended length of 6.56 ft. / 2 m.
 - The recommended DC fusing should be installed 18 in. / 0.45 m from the battery system's positive connection wire to the UPS.

Features

The UPS includes built-in USB and DB9 monitoring ports, six sets of output dry-contacts and one set of input contacts. A slot for an optional SNMP/Web network interface is included. The interactive front-panel LCD screen and set of three function keys enable local monitoring of UPS and site power status, as well as allow for setting a variety of UPS setup and control options.

UPS Front Panel

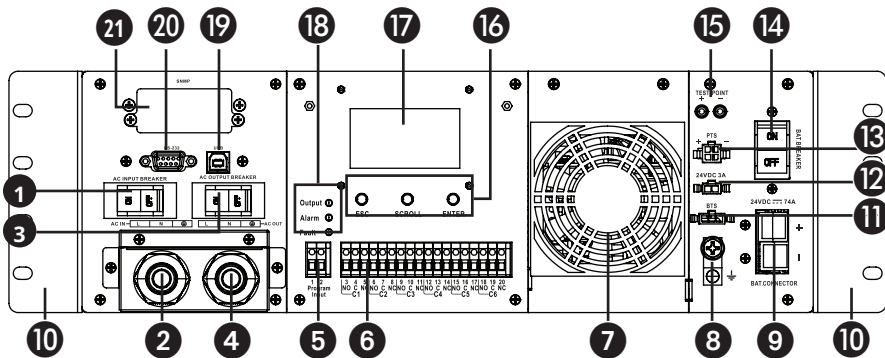

1 AC Input Breaker (30A)

The AC input breaker serves as both input overcurrent protection and an on/off switch to allow AC line power into the UPS. It must be switched ON for proper UPS operation.

2 AC Input Terminal Block (120V, 3 wires: L, N, G)

This terminal block is the UPS AC line power input.

- Wiring Gauge: 12 AWG recommended
- Torque Specifications: 13 in·lb (1.47 N·m)

3 AC Output Breaker (30A)

The AC output breaker serves as both output overcurrent protection and an on/off switch to allow UPS AC output to pass through to connected equipment. It must be switched ON for proper UPS operation.

4 AC Output Terminal Block (120V, 3 Wires: L, N, G)

This terminal block is the UPS AC line power output.

- Wiring Gauge: 12 AWG recommended
- Torque Specifications: 13 in·lb (1.47 N·m)

5 Input Contact (2 wires: Program Input 1 & 2)

To activate a programmable contact-closure input alarm to the UPS, short pins 1 & 2. Refer to LCD MENU TREE / SETTINGS / INPUT CONTACT section for more information.

- Wiring Gauge: Up to 12 AWG recommended
- Torque Specifications: 4.5 in·lb (.51 N·m)

Features

6 Dry Contacts: 6 Sets of Output Dry Contacts (C1, C2, C3, C4, C5, C6)

Each dry contact supports Normally-Open (NO) or Normally-Closed (NC) signaling. There are three wiring contact positions per channel (NO, C, NC). Refer to LCD MENU TREE / SETTINGS / DRY CONTACT section for more information.

- Wiring Gauge: Up to 12 AWG recommended
- Torque Specifications: 13 in•lb (1.47 N•m)

7 Internal Fan

The internal fan reduces operating temperature inside the UPS. The fan runs continuously when the UPS is running by pulling cool air from the front-side of the UPS and exhausting warmer air through the UPS rear vents. Do not block input or output ventilation. The fan can be replaced via the front panel by a trained electrical technician.

Note: If installing a replacement fan, make sure the fan is of equal size and rating.

8 Grounding Lug

This connector provides a permanent ground connection for the UPS.

- Wiring Gauge: 12 AWG recommended
- Torque Specifications: 13 in•lb (1.47 N•m)

9 Battery Connector

The external battery connector enables the connection of a 48V DC (SMART1548ET) or 24V DC (SMART1524ET) battery system to the UPS.

10 Rack-Mounting Brackets

The rack mounting brackets enable two-point mounting of the UPS into a 19-inch equipment rack enclosure. Screws are provided to attach the mounting brackets to the UPS power module. Rack-mount installation screws and hardware (if needed) are user-supplied.

11 Battery Temperature Connector

The battery temperature sensor is included with the UPS power module. The sensor reports temperature of the battery system to the UPS so that the most efficient charging profile can be used to keep batteries fully charged and increase battery lifespan. Connect the remote end of the temperature sensor to the negative terminal of the battery. Connect the other end of the sensor to the BTS connector on the UPS.



Installation and wiring requires a trained technician.

Features

12 External Fan Connector

This connector supplies 24V DC (SMART1524ET) or 48V DC (SMART1548ET) 3A maximum to power a user-supplied external fan to cool a UPS installed in an enclosure. The fan is powered ON via user-controllable temperature settings, as reported by the UPS system's built-in temperature sensor. An external fan power adapter cable is included with the UPS. Fan adapter wire gauge is 22 AWG.



Installation and wiring requires a trained technician.

13 PTS Control Connector

Connect the PTS / Power Transfer Switch option here.

14 External Battery Breaker (100A for 24V DC Systems, 60A for 48V DC Systems)

The External Battery Breaker serves as both DC input overcurrent protection and an on/off switch to allow DC battery power into the UPS. It must be switched on for proper UPS operation.

15 Battery Voltage Test Points

These test points allow you to measure battery voltage. They accept 2 mm diameter test probe tips. The battery circuit breaker must be ON to measure battery voltage. **CAUTION: The battery test points are for voltage sensing only and should NEVER be used as an output DC power source.**

16 Function keys (ESC, SCROLL, ENTER)

Located directly under the LCD panel, these buttons are used to operate and control the UPS via the LCD panel.

17 LCD Panel

The 2.5-inch LCD display enables control of UPS operation and settings.

18 Indicator LEDs

These LEDs with color-coded messaging report Output (green), Alarm (yellow) and Fault (red) status. Refer to the **Troubleshooting** section for alarm and fault messaging information.

19 USB Port

This optional USB port allows UPS management via local terminal console.

20 RS-232 Port

This optional RS-232 port allows UPS management via local console.

21 Network Interface Card Slot

This optional slot can be used with Tripp Lite's WEBCARDLXMINI accessory card and a limit of one optional "E2" environmental sensor for remote management and monitoring via secure web browser or SNMP protocols. See the documentation provided with the accessory card for installation and set-up configuration information.

Attention! - When the optional slot is in use, the RS-232/USB communications ports are disabled.

Mounting

It is recommended UPS equipment be mounted inside an enclosure to provide protection from weather conditions.

2-Post Rack Mounting the UPS

- 1 With the included screw set, attach the UPS mounting brackets.

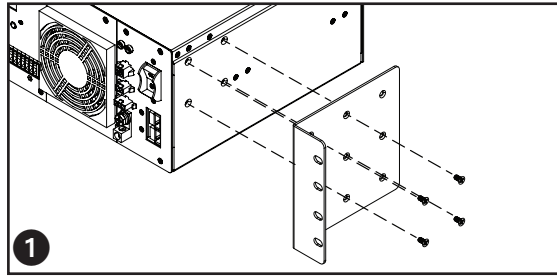

- 2 With user-supplied screws, attach the UPS to the forward mounting rails of the 2-post rack. Tighten all screws securely.

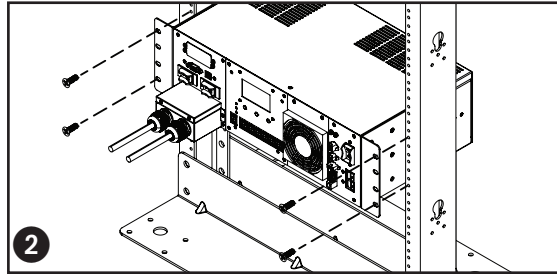

4-Post Rack Mounting the UPS

- 1 With the included screw set, attach the UPS mounting brackets.

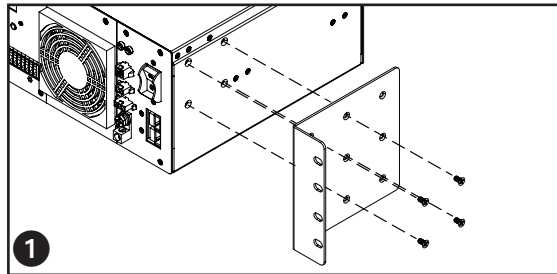

- 2 Attach the UPS mounting brackets to the forward mounting rails with user-supplied screws appropriate for the rack enclosure used. Tighten all screws securely.

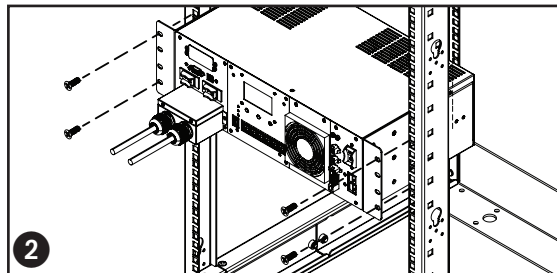

Mounting

Desktop Mounting the UPS

- 1 With the included screw set, attach the UPS mounting brackets.

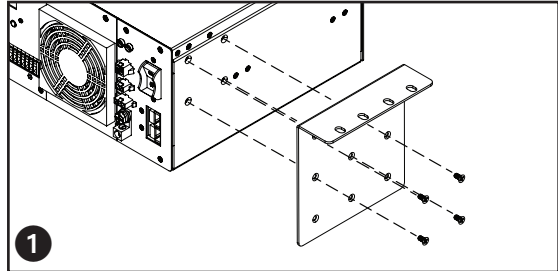

- 2 With user-supplied screws, attach the UPS to the desktop surface.

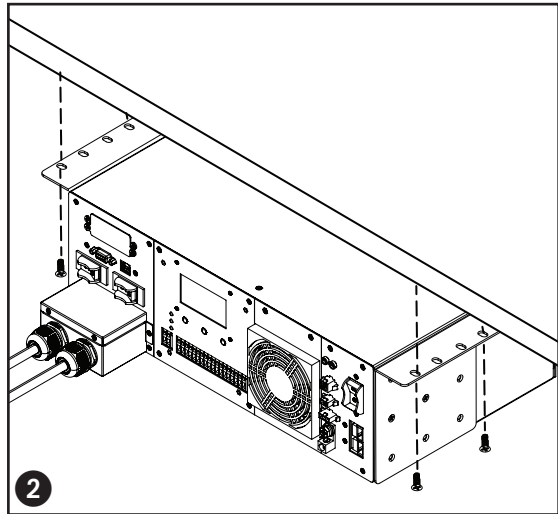

Models

SMART1524ET, SMART1548ET

UPS Dimensions (H x W x D)

5.24 x 15.75 x 9.45 in. / 133 x 400 x 240 mm

Wiring the UPS



WARNING! All electrical wiring must be performed by a qualified electrician or trained professional. Make sure line power is OFF. Switch OFF UPS input and output breakers before making any electrical connections. Adhere to all electrical codes when wiring the input connections.

AC Input and Output Wiring

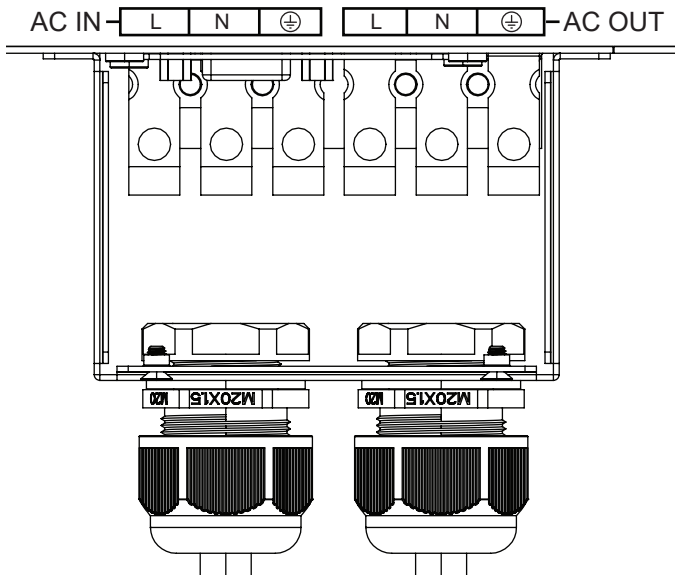

AC input and output wiring requires 12 AWG gauge wiring with a torque specification of 13 in·lb (1.47 N·m).

- Install the input and output hardwire terminal strain reliefs prior to securing AC wiring to the UPS.
- Connect 120V AC line power input to the L, N and G “AC IN” terminals of the UPS.
- Connect 120V AC UPS output from the L, N and G “AC OUT” terminals of the UPS to the connected equipment.

Wiring the UPS

External Battery Connections (Deep-Cycle Lead-Acid Batteries Only)

The UPS supports a user-supplied and assembled 24V DC (for SMART1524ET) or 48V DC (for SMART1548ET) battery system. The batteries used must be rechargeable, deep-cycle lead-acid type. Select batteries that meet your temperature requirements. Connect batteries into a 24V DC (SMART1524ET) or 48V DC (SMART1548ET) UPS system, as shown below. A battery bank of at least 100Ah, but not more than 200Ah, is recommended. For the battery set, the recommended battery cable gauges are 6 AWG for the SMART1524ET and 8 AWG for the SMART1548ET, with a maximum recommended length of 6.56 ft. / 2 m. The SMART1548ET requires a 48V 70A rated fuse bank. The SMART1524ET requires a 24V 150A rated fuse bank. The battery system attaches to the UPS via the included External Battery Connection Kit (refer to the External Battery DC Connector Cable Assembly instruction sheet for how to wire the external battery system to the UPS).

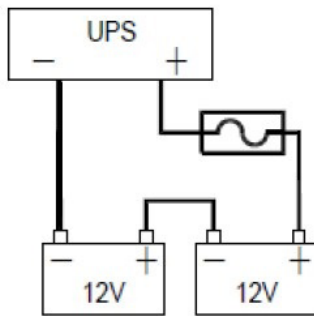

Battery Connection for 24V UPS System

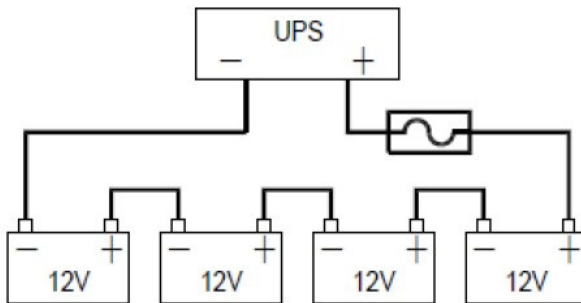

Battery Connection for 48V UPS System

Wiring the UPS

Additional Wiring Connections (Optional)

- USB connector
- DB9 RS-232 connector
- Output dry contacts
- Program input contacts
- WEBCARDLXMINI monitoring card and network cabling
- External fan connector adapter cable is included with the UPS. The recommended wire gauge for connection is 22 AWG.

Operation

Basic On/Off and Manual UPS Test Verification

Before powering on the UPS, make sure the batteries are fully charged and input line power is within the configured voltage limits of the UPS (factory default is 88 to 152V AC). The UPS will not turn on to provide AC output without a charged battery set connected. To verify proper operation and familiarize yourself with UPS operation, performing these three basic operations prior to putting the UPS into service is recommended.

1 Turn on the UPS in Line Power Mode

1.1 Switch "ON" the battery circuit breaker.

The fan and all LEDs will illuminate momentarily. The LCD display will report STARTUP, then the yellow ALARM LED will illuminate and a series of UPS status notification screens will be available to view.

1.2 Switch "ON" the AC Input circuit breaker.

For approximately 30 seconds, the UPS will monitor AC input line power and turn on if input is valid. The yellow ALARM LED will continue to illuminate. The LCD may report the initial turn-on sequence as recovery from a power failure. Press the ESC button to clear these notifications and view the main UPS status screen.

1.3 Switch "ON" the AC Output circuit breaker.

To power connected equipment, switch ON the AC output circuit breaker to enable UPS output. You may need to press the ESC button to clear any notifications and view the main UPS status screen.

2 Verify Battery Backup Operation

Note: Battery mode testing can be performed immediately after installation with a small test load. For testing at higher loads, it is recommended the battery bank be allowed to charge for 24 to 48 hours, or until the UPS reports 100% battery charge.

2.1 Switch the UPS from AC LINE POWER MODE to BATTERY MODE.

Switch OFF the AC input circuit breaker to simulate a power failure. The UPS will continue to provide AC output and the LCD screen will report BATTERY MODE, OUTPUT VOLTAGE and LOAD LEVEL PERCENTAGE.

Note: You may need to press the ESC BUTTON to clear any notifications resulting from the loss of AC input before viewing status and measurement values on the main UPS status screen.

2.2 Switch the UPS from BATTERY MODE to AC LINE POWER MODE.

Switch ON the AC input circuit breaker to return the UPS to AC line power mode. The UPS will maintain the output load and the LCD screen will report NORMAL MODE, OUTPUT VOLTAGE and LOAD LEVEL PERCENTAGE.

Notes:

- You may need to press the ESC BUTTON to clear any notifications resulting from restoring AC input before viewing status and measurement values on the main UPS status screen.
- If the UPS keeps switching between inverter and line mode, turn on the AVR buck and boost settings via LCD. If the UPS continues to switch between inverter and line mode with AVR engaged, change the UPS SENSE TYPE setting from UPS to GENERATOR.

Operation

3 Turn OFF the UPS

3.1 Switch OFF the OUTPUT circuit breaker.

Switch OFF the output circuit breaker to interrupt power to connected equipment.

3.2 Switch OFF the BATTERY circuit breaker.

Switch OFF the battery circuit breaker to interrupt battery power connected to the UPS.

3.3 Switch OFF the INPUT circuit breaker.

Switch OFF the input circuit breaker to interrupt AC line power connected to the UPS.

All LEDs and the LCD screen will immediately turn OFF.

Operation

Operating the LCD / LED Control Panel

The Control Panel includes a four-line LCD display, three indicator LEDs, three LCD function buttons, set of two program input contacts and six sets of dry contact outputs.

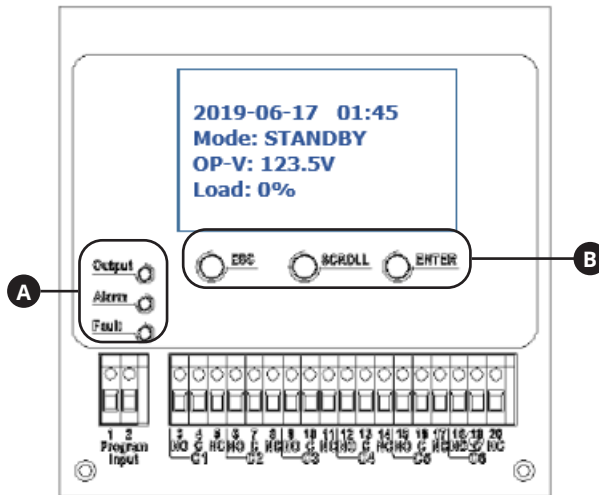

A LED Indicators

• Output LED (Green)

- Solid ON: AC output is on (UPS is operating in LINE POWER MODE).
- Flashing OFF and ON: AC output is on (UPS is operating in BATTERY MODE).
- OFF: AC output is off. The output LED will be off when a local or remote AC Output "OFF" control command is executed from the LCD, WEB or Terminal Console session.

• Alarm LED (Yellow)

- Solid ON: UPS output is on.
There is an active alarm indicating a condition not serious enough to keep the UPS from providing output power.

• Fault LED (Red)

- Solid ON: UPS output is off.
There is an active alarm indicating a serious condition that caused the UPS to stop providing output.

B LCD Function Buttons

- **ESC:** Moves the LCD back to the previous menu or page.
- **SCROLL:** Moves the LCD forward to the next selection or page.
- **ENTER:** Confirms selection of the scrolled value or sub-menu function.

Operation

LCD Menu Tree

The LCD MAIN MENU is viewable by pressing the ENTER button anytime you are viewing the Main UPS Status Screen. There are 5 MAIN MENU options:

1. STATUS
2. EVENT LOG
3. SETTINGS
4. CONTROL
5. HELP

LCD Menu Overview

Each of the menu options can be used to receive detailed UPS status information, enable user configuration options and perform operational testing. Use the LCD function buttons to scroll, view, select and enter on-screen information. Below is a detailed overview listing of the 5 MAIN MENU LCD items:

1.STATUS	2.EVENT LOG	3.SETTINGS	4.CONTROL	5. HELP
SERIAL NO.	ACTIVE LOG	DRY CONTACT	SELF TEST	UPS MODEL NUMBER
I/P-V (Input volts)	HISTORY LOG	INPUT CONTACT	DRY TEST	
I/P-F (Input Hz)		AVR FEATURE	EXT FAN TEST	
BAT V (Battery volts)		LINE QUALIFY	ON/OFF CTRL	
BAT T (Battery temp)		LINE DETECT	EVENT/TM RESET	
O/P-V (Output volts)		SENSE TYPE		
O/P-F (Output Hz)		BAT TEMP COMP		
O/P-P (Output VA)		EXT. FAN		
O/P-P (Output W)		BAT LOW VOLT		
LOAD (Load %)		CHARGER		
RunTM (Runtime remaining)		BATT CAP		
InvEV (Battery events)		BATT COEF		
InvTM (Battery time)		BATT GROUP		
BukEV (Buck events)		BACKUP TIMER		
BukTM (Buck time)		DEFAULT UPS		
BstEV (Boost events)		DEFAULT SNMP		
BstTM (Boost time)		BACKLIGHT		
C1 (C1 status)		TEST TIME		
C2 (C2 status)		SET DATE TIME		
C3 (C3 status)		PASSWORD		
C4 (C4 status)				
C5 (C5 status)				
C6 (C6 status)				
MainFW (Firmware)				
LCDFW (Firmware)				
HW (Version)				

Operation

LCD Menu Explanations

1. **STATUS:** There are six UPS STATUS information screens that report detailed information on UPS operating factors and current site power conditions.

First STATUS Screen (3 selections)

- **S/N** (UPS serial number)
- **I/P-V** (UPS input line voltage)
- **I/P-F** (UPS input line frequency, Hz)

Second STATUS Screen (4 selections)

- **BAT V** (UPS battery voltage)
- **BAT T** (UPS battery sensor temperature)
- **O/P-V** (UPS output voltage)
- **O/P-F** (UPS output frequency, Hz)

Third STATUS Screen (4 selections)

- **O/P-P...VA** (UPS output load in VA)
- **O/P-P...W** (UPS output load in watts)
- **LOAD** (UPS output load percentage)
- **RunTM** (Runtime remaining)

Fourth STATUS Screen (4 selections)

- **InvEV** (Number of battery events since last reset)
- **InvTM** (Total hours on battery mode since last reset)
- **BuKEV** (Number of times in BUCK mode since last reset)
- **BuKTM** (Total hours in BUCK mode since last reset)

Fifth STATUS Screen (6 selections)

- **BstEV** (Number of times in BOOST mode since last reset)
- **BstTM** (Total hours in BOOST mode since last reset)
- **C1** (Off-On status of C1 output contact)
- **C2** (Off-On status of C2 output contact)
- **C3** (Off-On status of C3 output contact)
- **C4** (Off-On status of C4 output contact)

Sixth STATUS Screen (5 selections)

- **C5** (Off-On status of C5 output contact)
- **C6** (Off-On status of C6 output contact)
- **MainFW** (UPS firmware version)
- **LCDFW** (UPS LCD firmware version)
- **HW** (UPS hardware version)

Operation

2. **EVENT LOG:** There are two UPS EVENT LOG information pages to report active and logged events.

First EVENT LOG Screen (1 selection)

- **ACTIVE LOG** (Displays all active UPS notifications)

Second EVENT LOG Screen (1 selection)

- **HISTORY LOG** (View or clear logged notifications)
 - Select INQUIRY to display past notifications (200 events maximum)
 - Select CLEAR to delete all past notifications

3. **SETTINGS:** There are four UPS SETTINGS pages that enable user configuration options. Each of these pages contain multiple sub-menu options.

Note: *PASSWORD REQUIRED. (Factory default password is 1111)*

Enter the default password by using the scroll button to select the numerical value. Press the Enter button after every value. The LCD message will confirm that it has accepted the password.

If the wrong password is used, the LCD screen will report "**ACCESS DENIED!**" Re-enter the correct password.

- Upon successful UPS setting change, the screen will report "**SETTING OK!**"
- If the setting is not accepted by the UPS, the screen will report "**SETTING FAILED!**"

First SETTINGS Screen (4 selections)

- **DRY CONTACT:** Enables configuration of UPS output dry contacts. Navigate via LCD panel to dry contacts C1/C2/C3/C4/C5/C6. Configure each contact to match the desired notification type. Disable any unused contacts. Selection options for each contact include:

ON BATTERY (Energizes when UPS is in battery mode)

BATTERY LOW (Energizes in battery mode when batteries are low)

TIMER TIME UP (Energizes in battery mode after the configured time threshold)

SUMMARY ALARM (Energizes when any UPS alarm occurs)

UPS FAULT (Energizes when any UPS fault occurs)

UPS SHUTDOWN (Energizes when UPS output is off)

DISABLE (Dry contact is not energized)

- **INPUT CONTACT:** Enables configuration of one user-supplied UPS input CONTACT-CLOSURE sensor. Navigate via LCD panel to select the closest naming option for the reported condition from the sub-menu list. Once configured, shorting the input sensor contacts will report the external condition by the selected name. Contact closure sensor naming options include:

USER PROGRAM (Use this naming option for other sensor types)

EXT. ALARM (External alarm)

EXT. BAT ALARM (External battery alarm)

EXT. FAN FAILED (External fan failure)

DOOR UNLOCK (Door unlock)

Note: *Select "User program" if your sensor type is not listed.*

Operation

- **AVR FEATURE:** Enables configuration of AVR / AUTO-VOLTAGE REGULATION to correct undervoltage and overvoltage conditions. Undervoltage Correction (BOOST) and Overvoltage Correction (BUCK) functions can be enabled and disabled independently of each other. To configure, navigate via LCD panel to the BUCK and BOOST screens and select ENABLE/DISABLE for each from the sub-menu list. Selection options include:
 - BOOST** (Select to ENABLE/DISABLE brownout boost protection)
 - BUCK** (Select to ENABLE/DISABLE overvoltage buck protection)
- **LINE QUALIFY:** Enables configuration of the amount of time the UPS monitors line power quality for stability before switching to LINE POWER MODE as AC power is restored. To configure, navigate via LCD panel to the LINE QUALIFY screen and select the desired time duration from the sub-menu list (default value = 30 SEC.). Selection options include:
 - 3 SEC.** (UPS returns to line-power mode after 3 seconds of valid AC input)
 - 10 SEC.** (UPS returns to line-power mode after 10 seconds of valid AC input)
 - 30 SEC.** (UPS returns to line-power mode after 30 seconds of valid AC input)

Second SETTINGS Screen (4 selections)

- **LINE DETECTION:** Enables configuration of the switchover voltages between AC and BATTERY modes, plus AVR activation voltages for AVR BOOST and AVR CUT operation. To configure, navigate via LCD to the LINE DETECT screen and select the desired transfer voltage points for each of the six conditions. Selection options include:
 - LINE HIGH** (Sets the high UPS transfer voltage from line-power mode to battery mode)
Note: Specify LINE HIGH switchover voltage via LCD (default = 152V AC).
 - LINE LOW** (Sets the low UPS transfer voltage from line-power mode to battery mode)
Note: Specify LINE LOW switchover voltage via LCD (default = 88V AC).
 - HIGH GAP** (Sets the threshold voltage used to calculate the transition from battery-power mode back to line-power mode. Default = 5V AC.)
 - LOW GAP** (Sets the threshold voltage used to calculate the transition from battery-power mode back to line-power mode. Default = 5V AC.)
 - BOOST VOLT** (Sets the low UPS boost-mode activation voltage for undervoltage correction)
Notes:
 - Specify BOOST VOLT activation setting for AVR boost mode operation (default = 102V AC).
 - Boost mode automatically deactivates as the input voltage recovers to the BOOST VOLT + LOW GAP value. (Default = 102V AC + 5V AC = 107V AC.)

Operation

BUCK VOLT (Sets the high UPS buck-mode activation voltage for overvoltage correction)

Notes:

- *Specify BUCK VOLT activation setting for AVR buck-mode operation (default = 128V AC).*
- *Buck mode automatically deactivates as the input voltage recovers to the BUCK VOLT - HIGH GAP value. (Default = 128V AC - 5V AC = 123V AC.)*
- **SENSE TYPE:** Enables configuration of UPS AC power sensing to maximize UPS operation for standard line power AC and generator power applications. To configure, navigate via LCD panel to the SENSE TYPE screen and select the desired input power configuration to the UPS or GENERATOR (default) setting. Selection options include:

UPS (UPS is configured for standard AC line power)

GENERATOR (UPS is configured for generator power applications)

- **BAT TEMP COMP:** Enables configuration of UPS BATTERY TEMPERATURE COMPENSATION-related float voltage reduction during high temperature conditions in mV/°C/Cell units. To configure, navigate via LCD panel to the BAT TEMP COMP screen and select the desired temperature compensation value. Selection options include:

REDUCE BY -2.5mV

REDUCE BY -3.0mV (default value)

REDUCE BY -3.5mV

REDUCE BY -4.0mV

- **EXT. FAN:** Enables configuration of EXTERNAL FAN activation temperature. To configure, navigate via LCD to the EXT. FAN screen and select the desired temperature for the external fan to turn on (default = 25C).

Third SETTINGS Screen (4 selections)

- **BAT LOW VOLT:** Enables configuration of BATTERY LOW VOLTAGE for notification that batteries are nearly depleted as the UPS is running in battery mode. To configure, navigate via LCD to the BAT LOW VOLT screen and select the desired low-battery voltage setting.
SMART1548ET selection options are 42.0 to 55.0V DC (default value is 46V DC)
SMART1524ET selection options are 21 TO 27.5V DC (default value is 23V DC)
- **CHARGER:** Enables configuration of CHARGER CURRENT. To configure, navigate via LCD to the CHARGER I screen and select the desired maximum charging current. Selection options are: 2 AMP, 4 AMP, 6 AMP, 8 AMP and 10 AMP (default = 2AMP).

Operation

- **BATTERY CAPACITY:** Enables configuration of external battery pack capacity. To configure, navigate via LCD to the BAT CAP setting screen and select the desired capacity.

7Ah

9Ah (default value)

10Ah

12Ah

17Ah

26Ah

40Ah

65Ah

100Ah

- **BATTERY COEFFICIENT:** Enables adjustment of battery coefficient as battery system ages to provide a better estimation of runtime remaining. To configure, navigate to the Bat Coef screen and enter a coefficient setting from 0.5-2.0 (default value = 1.0).

Fourth SETTINGS Screen (4 selections)

- **BAT GROUP:** Enables adjustment to the size of external battery system capacity by groups. If you are using a 200Ah battery system (2x 100Ah batteries), you would set battery group to 2. To configure, navigate to the Bat Group screen and enter the desired configuration. Settings range from 01-10 (01 is default value).
- **BACKUP TIMER:** Enables configuration of the BACKUP TIMER. This is the amount of runtime the UPS supports in battery mode before sending a configured dry contact notification. To configure, navigate to the BACKUP TIMER screen and select the desired duration. Selection options are between 0 and 480 minutes, in increments of 15 minutes (default = 120 min.).
- **DEFAULT UPS:** Returns the UPS back to the factory default configuration. To configure, navigate to the DEFAULT UPS screen and select the YES option.
- **DEFAULT SNMP:** Reserved for future use.

Fifth SETTINGS Screen (4 selections)

- **BACKLIGHT TIMER:** Selecting this option enables adjustment the amount of time the LCD BACKLIGHT will stay on. To configure, navigate to the BACKLIGHT screen and select the desired setting. Selection options are: 5 MIN. and ALWAYS (default = 5 MIN).
- **TEST TIMER:** Enables the configuration of the UPS TEST TIME, the maximum duration that the UPS will perform a battery mode self-test. To configure, navigate to the TEST TIME screen and enter the desired maximum test time duration from 1 to 255 minutes (factory default is 1 minute).
- **SET DATE TIME:** Enables the configuration of the UPS YEAR, DATE and TIME. To configure, navigate to the SET DATE TIME screen and enter the year, date and current time.

Operation

- **PASSWORD:** Enables the selection of a new, user-selected 4-digit password. To configure the UPS with a new password, navigate to the PASSWORD screen and select the SELECTING PASSWORD on-screen option. The UPS will request a new 4-digit password be entered. Once entered, the UPS will display SETTING AGAIN and request the same 4-digit password be entered again for confirmation.

***Note:** Factory default password is 1111; please keep track of the new password to enable future settings and control changes.*

4. **CONTROL:** There are two pages of UPS CONTROL settings that are available to perform testing, display output power status and reset UPS events. Each of these pages contain sub-menu UPS control options.

***Note:** PASSWORD REQUIRED. (Factory default password is 1111)*

First CONTROL Screen (4 items)

- **SELF TEST:** Selecting the SELF TEST option will cause the UPS to switch to battery mode for the duration selected in the SETTINGS/TEST TIME field (factory default is one minute). The UPS must be in Normal, Boost or Buck mode before a self-test will successfully initiate. To initiate a SELF TEST, navigate to the SELF TEST screen and select the START option. Once entered, the UPS will switch to battery mode to test the battery, inverter and battery transfer circuits for proper operation. To interrupt a self-test, select the STOP option from the SELF-TEST screen.
- **DRY TEST:** Selecting the DRY CONTACT TEST option will simultaneously test all output dry contacts for 1 minute. To initiate a DRY CONTACT TEST, navigate to the DRY TEST screen and select ON or OFF for the desired testing configuration. Selection options include:
 - Select **ON** to energize all 6 dry contacts for 1 minute
 - Select **OFF** to de-energize all 6 dry contacts for 1 minute
 - Select **CANCEL** to cancel the test immediately
- **EXT FAN TEST:** Selecting the EXTERNAL FAN TEST option will test the external fan for a period of 1 minute. To initiate an EXTERNAL FAN TEST, navigate to the EXT FAN TEST screen and select ON or OFF for the desired testing configuration. Selection options include:
 - Select **ON** to energize the external fan for a period of 1 minute
 - Select **OFF** to de-energize the external fan for a period of 1 minute
 - Select **CANCEL** to cancel the test immediately
- **ON/OFF CONTROL:** Selecting the UPS OUTPUT option enables the setting of UPS output power to be OFF or ON in Inverter, Boost, Buck and Normal modes. To turn UPS OUTPUT OFF or ON in these operating modes, navigate to the UPS OUTPUT screen and select the ON or OFF setting.
 - Select **ON** to enable UPS output in Inverter, Boost, Buck and Normal modes
 - Select **OFF** to disable UPS output in Inverter, Boost, Buck and Normal modes

Operation

Second CONTROL Screen (1 item)

- **EVENT/TM RESET:** Selecting the EVENT/TM RESET option resets all EVENTS and TIME DURATIONS stored in the UPS. To reset all events and times, navigate to the RESET EVENT/TM screen and select YES or NO from the sub-menu options.

Select **YES** to reset all Events and Time Durations

Select **NO** to keep all stored Events and Time Durations

5. **HELP:** The HELP menu item displays UPS MODEL NUMBER information. To display the UPS model number, navigate to the HELP screen and press the Enter button. Then press the Esc button to return to previous menu.

6. COMMUNICATIONS

Your UPS can be configured, managed and monitored via one of the available communication ports listed below. Choose the connection type most suitable for your application environment.

- **ACCESSORY CARD SLOT:** This optional slot can be used with Tripp Lite's WEBCARDLXMINI accessory card and a limit of one optional "E2" environmental sensor for remote management and monitoring via secure web browser or SNMP protocols. See the documentation provided with the accessory card for installation and set-up configuration information.

Attention! When the optional slot is in use, the RS-232/USB communications ports are disabled.

- **RS-232 / USB CONSOLE:** The front-panel RS-232 and USB monitoring ports enable local monitoring of UPS status, viewing event logs, setting parameters and controlling the UPS using a terminal emulation program, such as Windows HyperTerminal. To use this feature, connect a computer to either the RS-232 or USB port and open your terminal emulation program. Setup and operation using Windows HyperTerminal is included here and will vary by the VT-100 terminal emulation program used.

Operation

RS-232 / USB Communications Interface

UPS settings, control and status functions can be accessed using Windows HyperTerminal. The RS-232 / USB menus are hierarchical. Press ENTER to access the main menu. Type in the sub-menu number and press ENTER to access a particular sub-menu. Press the ESC key to return to the prior menu. Press ENTER to refresh the screen or the Status, Faults and Alarms readouts. The main menu displays the sub-menu line numbers, line status, output status and any faults or alarms that may be present.

The MAIN MENU screen with complete status information is shown below the console setup instructions.

HyperTerminal Set Up

- 1 Open the Windows HyperTerminal program.



- 2 The CONNECTION DESCRIPTION screen will display. Enter a name and select an icon for your UPS, then click OK.



Operation

- 3 The CONNECT TO screen will display. Select the COM port from the drop-down menu, then click OK.

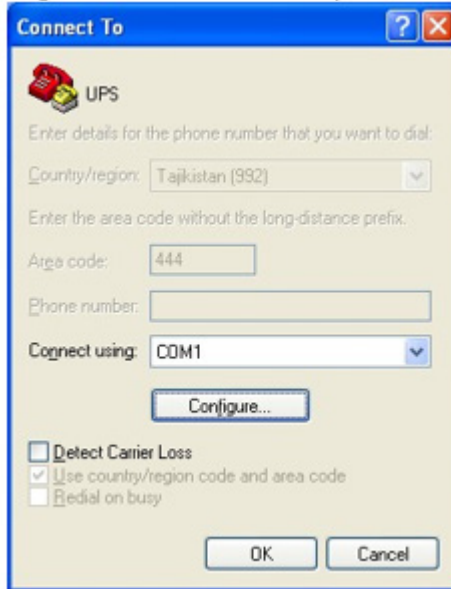

- 4 The COM PROPERTIES screen will display. Select the port setting as shown, then click OK.

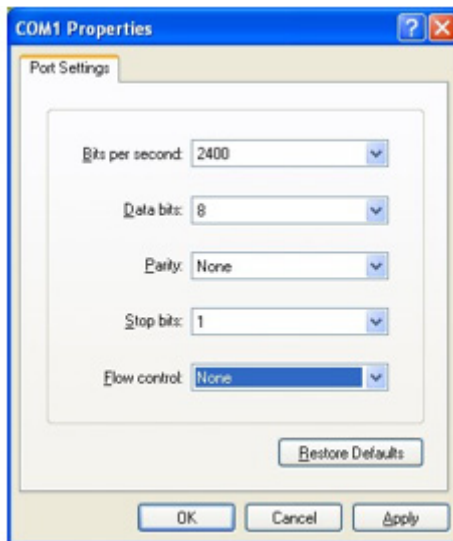

Operation

- 5 A blank window with the entered device name will display. Select PROPERTIES from the FILE MENU and click on it.

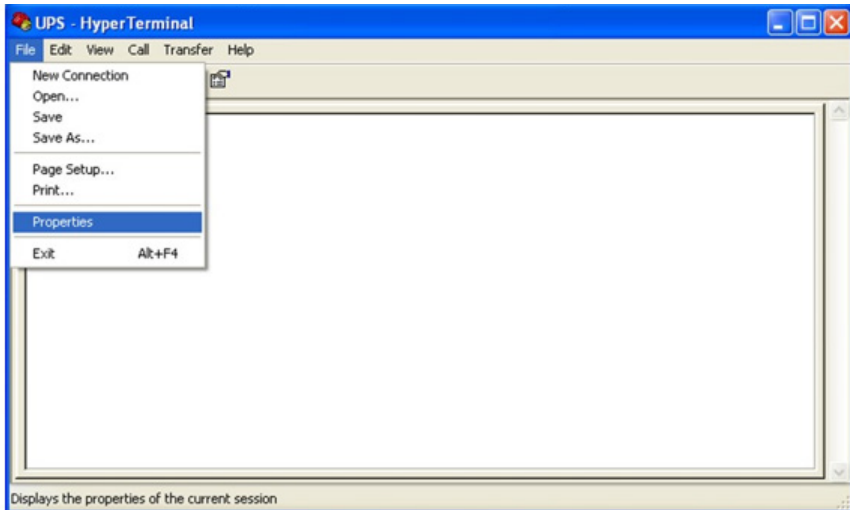

- 6 The PROPERTIES screen will display. Click to open the SETTINGS tab and select options as displayed here, then click to open the on-screen ASCII SETUP option.

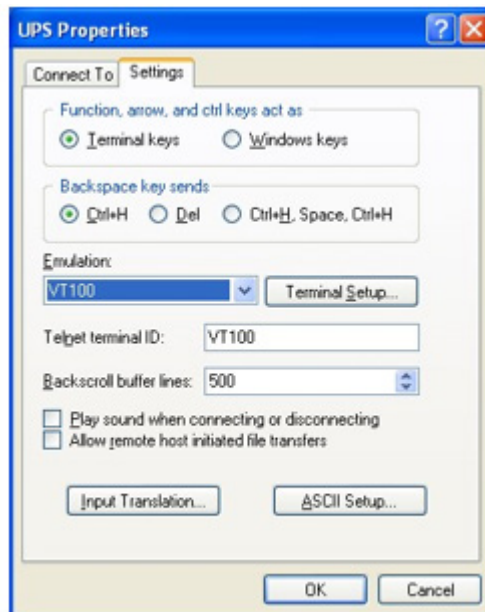

Operation

- 7 The ASCII SETUP window will open. Select the options as shown here, then press OK to complete your HyperTerminal setup.

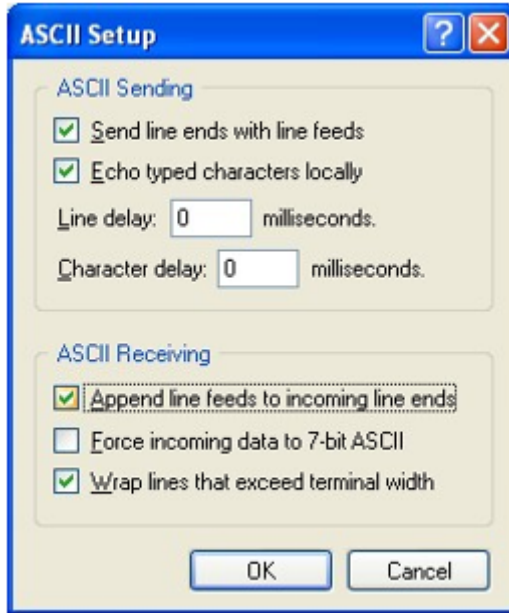

Operation

RS-232 / USB Main Menu

UPS settings, control and status functions can be accessed using Windows HyperTerminal. The RS-232 / USB menus are hierarchical. Press ENTER to access main menu. Type in the sub-menu number and press ENTER to access a particular sub-menu. Press ENTER to refresh the screen, the Status, Faults, and Alarms readouts. The main menu displays the sub-menu line numbers, line status, output status and any faults or alarms that may be present. The MAIN MENU with complete status information is shown here:

```
UPS Model: SMART1548ET / SMART1524ET
ID: ####
[0-MAIN MENU]
 1 Unit Specification
 2 Input / Output Values
 3 Control
 4 System Setting
 5 Line Conditioning Setup
 6 Programmable Contacts Setup
 7 Event Log View
 8 Login Administrator

Date & Time      : YEAR/MONTH/DAY, HOUR/MIN./SEC.
Sense Type      : [UPS/Generator]
Line Status     : [Normal]
Output Status   : [Normal]
Contact Status  :
  Contact C1 ==> [DISABLED]/NOT ACTIVATED]
  Contact C2 ==> [DISABLED]/NOT ACTIVATED]
  Contact C3 ==> [DISABLED]/NOT ACTIVATED]
  Contact C4 ==> [DISABLED]/NOT ACTIVATED]
  Contact C5 ==> [DISABLED]/NOT ACTIVATED]
  Contact C6 ==> [DISABLED]/NOT ACTIVATED]
Ext.Fan Status  : [Activated/Not Activated]
Faults         : [None]*
Alarms        : [None]*
```

*Default values shown. The full set of available display values for SENSE TYPE, LINE STATUS, OUTPUT STATUS, FAULTS and ALARMS fields are listed here.

- **SENSE TYPE:** UPS, Generator
- **LINE STATUS:** Normal, Not Good
- **OUTPUT STATUS:** Self Test, Inverter, Buck, Boost, Normal, Off
- **FAULTS:** Bus Voltage Over, Bus Voltage Under, Bus Soft Fail, Output Short, INV Output Voltage Low, INV Output Voltage High, Over Temperature, Fan Fault, Battery Voltage High, Overload

Operation

- **ALARMS:** Bus Voltage Over, Bus Voltage Under, Bus Soft Fail, Line Fail, Output Short, INV Output Voltage Low, INV Output Voltage High, Over Temperature, Fan Fault, Battery Voltage High, Battery Voltage Low, Overcharge, Battery Voltage Under, Temp Derating, Overload, Eeprom Fault, Battery Temperature Low, Battery Temperature High, BTS Disconnect, Battery Disconnect

RS-232/USB Menu Tree

Note: It is recommended to enter passwords in 8 LOGIN ADMINISTRATOR first for access to sub-menu 3~7. The factory default password is **1111**.

The UPS menu tree is shown below:

```
UPS Model: SMART1548ET / SMART1524ET
ID: ####
[0-MAIN MENU]
 1 Unit Specification
 2 Input / Output Values
 3 Control
 4 System Setting
 5 Line Conditioning Setup
 6 Programmable Contacts Setup
 7 Event Log View
 8 Login Administrator
```

Menu Overview

These menu options can be used to receive detailed UPS status information, enable user configuration options and perform operational testing. Use your terminal emulation software to view, select and enter on-screen information. A detailed overview listing each of the 8 MAIN MENU LCD item is listed below:

1. Unit Specifications - This screen reports basic specifications for the UPS.

```
[0-MAIN MENU]
[1-Unit Specifications]
Unit Model           SMART1548ET / SMART1524ET
Unit Frequency      60 Hertz
Output Voltage      120 Volts
Output VA           1500VA
Battery Voltage ## Volts
Max Chgr Current    ##.#A
Panel Firmware Ver  ##.##
Main Firmware Ver   ##.##
Hardware            Ver  ##.##
```

Operation

2. Input / Output Values - This screen reports UPS input and output values.

```
[0-MAIN MENU]
[2-INPUT/OUTPUT VALUES]
Input:-
Voltage          ###.# Vac
Frequency        ##.# Hz
Output:-
Voltage          ###.# Vac
Frequency        ##.# Hz
Power            ##### Watt
VA              ##### VA
Load Percent     ### %
Battery:-
Temperature      ## Deg C
Voltage          ##.## Vdc
Event-Timer
INVERTER EVENTS #####
INVERTER TIMER  ###.# Hours
Boost EVENTS     #####
Boost TIMER     ###.# Hours
Buck EVENTS     #####
Buck TIMER      ###.# Hours
```

3. UPS Control Actions - This screen offers control of UPS operation.

```
[0-MAIN MENU]
[3-Control]
30) Self Test
31) Dry Contact Test
32) External Fan Test
33) Ups Output
34) Event/Timer Reset
```

UPS Control Sub-Menu Options

Self Test (#30) - Selecting the SELF TEST option will cause the UPS to switch to battery mode for the duration selected in the SETTINGS/TEST TIME field (factory default is one minute). The UPS must be in Normal, Boost or Buck mode before a self-test will successfully be initiated. To initiate a SELF TEST, navigate to the SELF TEST screen and select the START option. Once entered, the UPS will switch to battery mode to test the battery, inverter and battery transfer circuits for proper operation.

```
Self Test
0) Stop
1) Start
>
```

Operation

Dry Contact Test (#31) - Selecting the DRY CONTACT TEST option will simultaneously test all output dry contacts for 1 minute. To initiate a DRY CONTACT TEST, navigate to the DRY TEST screen and select ON or OFF for the desired testing configuration.

```
Dry Contact Test
0) Off
1) On
2) Cancel
>
```

External Fan Test (#32) - Selecting the EXTERNAL FAN TEST option will test the external fan for a period of 1 minute. To initiate an EXTERNAL FAN TEST, navigate to the EXT FAN TEST screen and select ON or OFF for the desired testing configuration.

```
External Fan Test
0) Off
1) On
2) Cancel
>
```

UPS Output (#33) - Selecting the UPS OUTPUT option enables the setting of UPS output power to be OFF or ON in Inverter, Boost, Buck and Normal Modes. To turn UPS OUTPUT OFF or ON in these operating modes, navigate to the UPS OUTPUT screen and select the ON or OFF setting.

Select **ON** to enable UPS output in Inverter, Boost, Buck and Normal modes. Select **OFF** to disable UPS output in Inverter, Boost, Buck and Normal modes.

```
UPS Output
0) off
1) On
>
```

Reset Event (#34) - Selecting the RESET EVENT/TM option resets all EVENTS and TIME DURATIONS stored in the UPS. To reset all events and times, navigate to the RESET EVENT/TM screen and select YES or NO from the sub-menu options.

```
Reset Event/TM
0) No
1) Yes
>
```

Operation

4. UPS System Setting - This screen offers control of UPS operating settings.

```
[0-MAIN MENU]
[4-SYSTEM SETTING]
 40) Ext Fan On By Temperature
 41) Battery Low Voltage
 42) Charging Current
 43) Bat cap
 44) Bat coef
 45) Bat group
 46) Battery Temperature Compensation
 47) Test Timer
 48) Backup Timer
 49) LCD BackLight Timer
 50) Set To Default UPS
 51) Set Date
 52) Set Time
 53) Change Password
 54) Reset Password
```

System Setting Control Sub-Menu Options

External Fan On By Temperature (#40) - Selecting the EXTERNAL FAN ON BY TEMPERATURE option enables configuration of the EXTERNAL FAN activation temperature. To configure, navigate to the EXT. FAN screen and select the desired temperature for the external fan to turn on (default = 25C).

```
[0-MAIN MENU]
[4-SYSTEM SETTING]
  [40-EXT FAN ON BY TEMPERATURE]
  Current setting is [## Deg C]
  Enter new value. (20->50)
  >
```

Battery Low Voltage (#41) - Selecting the BATTERY LOW VOLTAGE option enables configuration of the low-voltage notification that batteries are nearly depleted as the UPS is running in battery mode. To configure, navigate via LCD to the BATTERY LOW VOLTAGE screen and select the desired low-battery voltage setting (SMART1548ET default is 46VDC / SMART1524ET default value is 20V DC).

```
[0-MAIN MENU]
[4-SYSTEM SETTING]
 [41-BATTERY LOW VOLTAGE]
  Current setting is [##.# Volts]
  Enter new value. [42.0->55.0]
  >
```

Operation

Charging Current (#42) - Selecting this option enables configuration of CHARGER CURRENT. To configure, navigate to the CHARGER screen and select the desired maximum charging current. Selection options are: 2 AMP, 4 AMP, 6 AMP, 8 AMP and 10 AMP (default = 2A).

```
[0-MAIN MENU]
[4-SYSTEM SETTING]
[42-Charging Current]
Current setting is [## amps]
0) Set to 2 amps
1) Set to 4 amps
2) Set to 6 amps
3) Set to 8 amps
4) Set to 10 amps
>
```

Battery Capacity (#43) - Selecting this option enables configuration of UPS BATTERY Capacity to match the AH of the individual batteries used in the user-supplied external battery bank. To configure, navigate to the BAT CAP screen and select the desired AH rating value to match the ratings of the individual batteries used.

```
[0-MAIN MENU]
[4-SYSTEM SETTING]
[43-BATCAP]
Current setting is [009 AH]
0) Set to 7 AH
1) Set to 9 AH
2) Set to 10 AH
3) Set to 12 AH
4) Set to 17 AH
5) Set to 26 AH
6) Set to 40 AH
7) Set to 65 AH
8) Set to 100 AH
>
```

Battery Coefficient (#44) - Selecting this option enables adjustment of battery coefficient as battery system ages to provide a better estimation of runtime remaining. To configure, navigate to the Battery Coef screen and select a coefficient value from 0.5->2.0 (default value = 1.0).

```
[0-MAIN MENU]
[4-SYSTEM SETTING]
[44-Battery Coef]
Current setting is [1.0]
Enter new value. (0.5->2.0)
>
```

Operation

Battery Group (#45) - Selecting this option enables adjustment to the size of external battery banks' capacity by groups. If you are using a 200Ah battery system (2x 100Ah batteries), you would set the battery group to 2. To configure, navigate to the Battery group screen and select the desired configuration. Settings range from 01->10 (default value = 01).

```
[0-MAIN MENU]
[4-SYSTEM SETTING]
[45-Battery group]
Current setting is [01 ]
Enter new value (01->10)
>
```

Battery Temperature Compensation (#46) - Selecting this option enables configuration of UPS BATTERY TEMPERATURE COMPENSATION related float voltage reduction during high-temperature conditions in mV/°C/Cell units. To configure, navigate to the BAT TEMP COMP screen and select the desired temperature compensation value.

```
[0-MAIN MENU]
[4-SYSTEM SETTING]
[46-Battery Temperature Compensation]
Current setting is [-03mv/Deg C/Cell]
0) Set to -2.5mv/Deg C/Cell
1) Set to -3.0mv/Deg C/Cell
2) Set to -3.5mv/Deg C/Cell
3) Set to -4.0mv/Deg C/Cell
>
```

Test Timer (#47) - Selecting this option enables the configuration of the UPS TEST TIME, the maximum duration that the UPS will perform a battery mode self-test. To configure, navigate to the TEST TIME screen and enter the desired maximum test time duration from 1 to 255 minutes (factory default is 1 minute).

```
[0-MAIN MENU]
[4-SYSTEM SETTING]
[47-Test Timer]
Current setting is [001min)
Enter New Value
>
```

Operation

Backup Timer (#48) - Selecting this option enables configuration of the BACKUP TIMER. This is the amount of runtime the UPS supports in battery mode before sending a configured dry contact notification. To configure, navigate to the BACKUP TIMER screen and select the desired duration multiplier. Selection options between 1 and 32 increments. One increment is equal to 0.25 hours for a maximum of 8 hours (default = [08]* 0.25 hours = 2.0 hours).

```
[0-MAIN MENU]
[4-SYSTEM SETTING]
[48-Backup Timer]
Current setting is [08] (Unit=0.25Hour)
Enter new value
>
```

LCD Backlight Timer (#49) - Selecting this option enables adjustment of the LCD BACKLIGHT. To configure, navigate to the LCD BACKLIGHT screen and select the desired setting. Selection options are: 5 MIN. and ALWAYS (default = 5 MIN).

```
[0-MAIN MENU]
[4-SYSTEM SETTING]
[49-LCD BackLight Timer]
0) 5 min
1) Always
>
```

Set to Default UPS (#50) - Selecting this option enables factory default configuration of the UPS. To configure, navigate to the DEFAULT UPS screen and select the YES option.

```
[0-MAIN MENU]
[4-SYSTEM SETTING]
[50-Set to Default UPS]
0) No
1) Yes
>
```

Set Date (#51) - Selecting this option enables the setting of the UPS date. To configure, navigate to the SET DATE screen and enter the new YEAR / MONTH / DAY information.

```
[0-MAIN MENU]
[4-SYSTEM SETTING]
[51-Set Date]
Current Date is [YEAR-MONTH-DAY]
Enter new value [##-##-##]
>
```

Operation

Set Time (#52) - Selecting this option enables setting of the UPS time. To configure, navigate to the SET TIME screen and enter the new time. Time displays in 24-hour format (18:00 = 6PM).

```
[0-MAIN MENU]
[4-SYSTEM SETTING]
[52-Set Time]
Current Time is [HOUR:MINUTE:SECOND]
Enter new value [##:##:##]
>
```

Change Password (#53) - Selecting this option enables the selection of a new, user-selected 4-digit password. To configure the UPS with a new password, navigate to the PASSWORD screen. The UPS will request a new 4-digit password be entered. Once entered, the UPS will display SETTING AGAIN and request the same 4-digit password be entered again for confirmation. The factory default password is **1111**. Make sure to keep track of the new password to enable future settings and control changes.

```
[0-MAIN MENU]
[4-SYSTEM SETTING]
[53-Change Password]
Please Enter New Password:0000-9999
>
```

Reset Password (#54) - Select this option to reset the UPS back to the factory default administrator password of **1111**.

```
[0-MAIN MENU]
[4-SYSTEM SETTING]
[54-Reset Password]
0) No
1) Yes
>
```

Operation

- 5. Line Conditioning Setup** - This option allows customization of the UPS system's line-interactive voltage regulation capabilities. **CAUTION: Improperly parameter value setting can cause permanent damage to the unit. Changes should only be made by qualified and trained personnel.**

```
[0-MAIN MENU]
[5-LINE CONDITIONING SETUP]
55) Buck Function
56) Boost Function
57) Sense Type
58) Line Qualify Time
59) High Limit [152] Vac
60) Low Limit [088] Vac
61) Boost Low [102] Vac
62) Buck High [128] Vac
63) High Gap [005] Vac
64) Low Gap [005] Vac
*) High back [147] Vac
*) Low back [093] Vac
*) Boost back [107] Vac
*) Buck back [123] Vac
>
```

Line Conditioning Sub-Menu Options

Buck Function (#55) - Selecting this option allows users to enable or disable line interactive UPS overvoltage (BUCK) correction. Select ENABLE to turn on overvoltage regulation. Select DISABLE to turn off overvoltage regulation (default = Enabled).

```
[0-MAIN MENU]
[5-LINE CONDITIONING SETUP]
[55-Buck Function]
Current setting is [Enable]
0) Disable
1) Enable
>
```

Boost Function (#56) - Selecting this option allows users to enable or disable line interactive UPS undervoltage (BOOST) correction. Select ENABLE to turn on undervoltage regulation. Select DISABLE to turn off undervoltage regulation (default = Enabled).

```
[0-MAIN MENU]
[5-LINE CONDITIONING SETUP]
[56-Boost Function]
Current setting is [Enable]
0) Disable
1) Enable
>
```

Operation

Sense Type (#57) - Selecting this option enables configuration of UPS AC power sensing to maximize UPS operation for standard line power AC and generator power applications. To configure, navigate to the SENSE TYPE screen and select the desired input power configuration to the UPS or GENERATOR setting (default= GENERATOR).

```
[0-MAIN MENU]
[5-LINE CONDITIONING SETUP]
[57-SENSE TYPE]
Current setting is [Generator]
1) Generator
2) UPS
>
```

Line Qualify Time (#58) - Selecting this option enables configuration of the amount of time the UPS monitors line power quality for stability before switching to LINE POWER MODE as AC power is restored. To configure, navigate to the LINE QUALIFY screen and select the desired time duration from the sub-menu list (default = 30).

```
[0-MAIN MENU]
[5-LINE CONDITIONING SETUP]
[58-Line Qualify Time]
Current setting is [## Seconds]
0) Set to 3 seconds
1) Set to 10 seconds
2) Set to 30 seconds
>
```

High Limit (#59) - Selecting this option enables setting the high UPS transfer voltage from line-power mode to battery mode. To configure, navigate to the HIGH LIMIT screen and enter the desired voltage value (default = 152V).

```
HIGH LIMIT [###] Enter new value. [120->152]
>
```

Low Limit (#60) - Selecting this option enables setting the low UPS transfer voltage from line-power mode to battery mode. To configure, navigate to the LOW LIMIT screen and enter the desired voltage value (default = 88V).

```
LOW LIMIT [###] Enter new value. [088->120]
>
```

Boost Low (#61) - Selecting this option enables setting the boost-mode activation voltage for undervoltage (BOOST) correction. To configure, navigate to the BOOST LOW screen and enter the desired activation voltage (default = 102V).

```
BOOST LOW [###] Enter new value. [096->120]
>
```

Operation

Buck High (#62) - Selecting this option enable setting the buck-mode activation voltage for overvoltage (BUCK) correction. To configure, navigate to the BUCK HIGH screen and enter the desired activation voltage (default = 128V).

```
BUCK HIGH [###]   Enter new value. [120->144]
>
```

High Gap (#63) - Selecting this option adjusts the high UPS transfer voltage from Battery Mode to Line Power Mode OR AVR Buck mode to AVR Normal mode, relative to the configured HIGH LIMIT and BUCK HIGH transfer points (default = 5V).

- If (#59) HIGH LIMIT is set to 152V and the UPS switches to battery mode due to input voltage being greater than 152V, a setting of 5V in the HIGH GAP field would result in the UPS switching to AC mode when input voltage is reduced to 147V or lower. In this sample configuration, the HIGH BACK voltage value will automatically be set to 147V.
- If (#62) BUCK HIGH is set to 128V and the UPS switches to AVR Buck mode due to input voltage being greater than 128V, a setting of 5V in the HIGH GAP field would result in the UPS switching to Normal AVR mode when input voltage is reduced to 123V or lower. In this sample configuration, the BUCK BACK voltage value will be automatically set to 123V.

```
High Gap [005]   Enter New Value. (003->007)
>
```

Low Gap (#64) - Selecting this option adjusts the low UPS transfer voltage from Battery Mode to Line Power Mode OR AVR Boost Mode to AVR Normal mode, relative to the configured LOW LIMIT and BOOST LOW transfer points (default = 5V).

- If (#60) LOW LIMIT is set to 88V and the UPS switches to battery mode due to input voltage being less than 88V, a setting of 5V in the LOW GAP field would result in the UPS switching to AC mode when input voltage increases to 93V or higher. In this sample configuration, the LOW BACK voltage value will automatically be set to 93V.
- If (#61) BOOST LOW is set to 102V and the UPS switches to battery mode due to input voltage being less than 102V, as setting of 5V in the LOW GAP field would result in the UPS switching back to AC mode when input voltage increases to 107V or higher. In this sample configuration, the BOOST BACK voltage value will automatically be set to 107V.

```
Low Gap [005]   Enter New Value. (003->007)
>
```

Operation

High Back / Buck Back - The High Back view-only value displayed is based on the High Limit and High Gap settings. The Buck Back view-only value displayed is based on the Boost High and High Gap settings. See HIGH GAP (#63) for more information.

Low Back / Boost Back - The Low Back view-only value displayed is based on the Low Limit and Low Gap settings. The Boost Back view-only value displayed is based on the Boost High and Low Gap settings. See LOW GAP (#64) for more information.

```
*) High back [### Vac]
*) Low back [### Vac]
*) Boost back [### Vac]
*) Buck back [### Vac]
```

- 6. Programmable Contacts Setup** - This option allows customization of the notification configuration for the UPS six output dry contacts and one input contact.

```
[0-MAIN MENU]
[6-PROGRAMMABLE CONTACTS SETUP]
70) Contact C1 = [Disabled]
71) Contact C2 = [Disabled]
72) Contact C3 = [Disabled]
73) Contact C4 = [Disabled]
74) Contact C5 = [Disabled]
75) Contact C6 = [Disabled]
76) PROGRAM I/P Contact = [EXT FAN FAILED]
>
```

Programmable Contacts Sub-Menu Options

Contacts C1, C2, C3, C4, C5, C6 - Selecting any of these six output dry contacts enables setting the appropriate notification type for each set of dry contacts. To configure reporting configurations for contacts C1 through C6, navigate to each contact individually and select the desired configuration from the list of seven available options (default configuration: C1 - C6 = DISABLED).

```
[0-MAIN MENU]
[6-PROGRAMMABLE CONTACTS SETUP]
[70-CONTACT C1]
Current Setting is [Disabled]
0) Set to [On Battery]
1) Set to [Battery Low]
2) Set to [Timer Time Up]
3) Set to [Summary Alarm]
4) Set to [UPS Fault]
5) Set to [UPS Shutdown]
6) Set to [DISABLED]
>
```

Operation

Program Input Contact - Selecting the PROGRAM I/P CONTACT option enables configuration of one user-supplied UPS input CONTACT-CLOSURE sensor. Navigate to select the closest naming option for the reported condition from the sub-menu list. Once configured, shorting the input sensor contacts will report the external condition by the selected name (contact closure sensor naming options are shown below). Select "User program" if your sensor type is not listed. Default setting is EXT FAN FAILED.

```
[0-MAIN MENU]
[6-PROGRAMMABLE CONTACTS SETUP]
  [76-PROGRAM I/P CONTACT]
    Current Setting is [EXT FAN FAILED]
    0) Set to [USER PROGRAM IN]
    1) Set to [EXT ALARM]
    2) Set to [EXT BATT ALARM]
    3) Set to [EXT FAN FAILED]
    4) Set to [DOOR UNLOCK]
    >
```

7. **Event Log** - This option enables viewing and resetting event log entries.

```
[0-MAIN MENU]
[7-EVENT LOG VIEW]
  77)Display Event Records
  78)Reset Event Log
  >
```

Event Log Sub-Menu Options

Display Event Records - Selecting this option enables viewing of up to 200 logged events. To view events, select the DISPLAY EVENT RECORDS option and pick from the four available ranges of numbered events. Once a range of events is selected, they will be available for viewing in a continuous list, each referenced by the corresponding Event Number, Date, Time and Event Type. Up to 200 records are stored. The oldest values will be automatically cleared once the maximum number of records is reached.

```
[0-MAIN MENU]
[7-EVENT LOG VIEW]
  77)Display Event Records
    0) Event #001-#050
    1) Event #051-#100
    2) Event #101-#150
    3) Event #151-#200
    >
```

Operation

Reset Event Log - To delete all logged events, select the RESET EVENT LOG option and confirm the choice by selecting the YES option. This option will delete all stored event records.

```
[0-MAIN MENU]
[7-EVENT LOG VIEW]
78)Reset Event Log
  0) No
  1) Yes
  >
```

- 8. Login Administrator** - This option enables password login with administrator status for access to all available console monitoring options, including setting and control sub-menus 3 through 7. Once the password is successfully entered, the interface will report SUCCESS TO ACCESS! (default password is **1111**).

```
[0-MAIN MENU]
[8-Login Administrator]
Please Enter Password
>1111
>
```

Troubleshooting

Alarm and Fault Messaging

The UPS displays a combination of LED and LCD messaging to alert you of potential UPS, Utility, and Battery mode issues.

Fault LED Conditions	LCD Fault Displays		
DC Bus Voltage > 300VDC	Bus Voltage Over	2020-03-05 12:00 Bus Over 1/4 ▼	Output ○ Alarm ● Fault ●
When unit starts, internal DC Bus voltage is < target voltage for 15sec+.	Bus Soft Fail	2020-03-05 12:00 BusSoft Fail 1/4 ▼	Output ○ Alarm ● Fault ●
Battery mode inverter output voltage is greater than 150VAC	INV Opv High	2020-03-05 12:00 INV Opv High 2/3 ▼	Output ○ Alarm ● Fault ●
Battery mode inverter output voltage is less than 96VAC	INV Opv Low	2020-03-05 12:00 INV Opv Low 2/3 ▼	Output ○ Alarm ● Fault ●
Internal UPS temperature is greater than 120C (248F)	Over Temp	2020-03-05 12:00 Over Temp 2/4 ▼	Output ○ Alarm ● Fault ●
Output Short Circuit	Output short	2020-03-05 12:00 Output Short 2/3 ▼	Output ○ Alarm ● Fault ●
Battery voltage higher than 60V for SMART1548ET and higher than 30V for SMART1524ET in Battery Mode	Bat High	2020-03-05 12:00 Bat High 3/3 ▲	Output ○ Alarm ● Fault ●
Output Overload	Over Load	2020-03-05 12:00 Over Load 2/3 ▼	Output ○ Alarm ● Fault ●

Troubleshooting

UPS Alarm Messages

The UPS Alarm LED is activated during Alarm and Fault Conditions.

Alarm LED Conditions	LCD Alarm Displays		
Environment temperature > 55C	Temp Derat	<div style="border: 1px solid black; padding: 2px;"> 2020-03-05 12:00 Temp Derat 2/3 ▼ </div>	Output <input type="radio"/> Alarm <input checked="" type="radio"/> Fault <input type="radio"/>
BTS temperature reading is below -20C	Bat Temperature Low	<div style="border: 1px solid black; padding: 2px;"> 2020-03-05 12:00 BatTemp Low 2/3 ▼ </div>	Output <input type="radio"/> Alarm <input checked="" type="radio"/> Fault <input type="radio"/>
BTS temperature reading is greater than 49C	BattTemp High	<div style="border: 1px solid black; padding: 2px;"> 2020-03-05 12:00 BatTemp High 2/3 ▼ </div>	Output <input checked="" type="radio"/> Alarm <input checked="" type="radio"/> Fault <input type="radio"/>
Battery voltage lower than 42.5V for SMART1548ET and lower than 21.3V for SMART1524ET	Battery Voltage Under	There is no special alarm window POP at this condition	

Troubleshooting

Are there LED/LCD messages for the following conditions?			
AC Line Power has failed or dropped below set transfer voltage	AC Fail	2020-03-05 12:00 AC Fail 1/3 ▼	Output <input type="radio"/> Alarm <input checked="" type="radio"/> Fault <input type="radio"/>
Fan is not working	Fan Fault	2020-03-05 12:00 Fan Fault 3/3 ▲	Output <input type="radio"/> Alarm <input checked="" type="radio"/> Fault <input type="radio"/>
Battery voltage higher than 62V for SMART1548ET and higher than 31V for SMART1524ET when charge on.	Overcharge	2020-03-05 12:00 Over Charge 3/3 ▲	Output <input type="radio"/> Alarm <input checked="" type="radio"/> Fault <input type="radio"/>
The UPS detects an output overload in line or battery modes and the overload countdown timer starts. If an overload is still present at the end of the countdown, the UPS will turn output off.	Overload	2020-03-05 12:00 Over Load 2/3 ▼	Output <input type="radio"/> Alarm <input checked="" type="radio"/> Fault <input type="radio"/>
EEPROM Check fail	EEPROM fault	2020-03-05 12:00 Eeprom Fault 2/3 ▼	Output <input type="radio"/> Alarm <input checked="" type="radio"/> Fault <input type="radio"/>
Battery Temp Sensor disconnected from UPS interface	BTS Disconnect	2020-03-05 12:00 BTS Disc 2/3 ▼	Output <input type="radio"/> Alarm <input checked="" type="radio"/> Fault <input type="radio"/>
	Battery Disconnect	2020-03-05 12:00 Bat Disc 3/3 ▲	Output <input checked="" type="radio"/> Alarm <input checked="" type="radio"/> Fault <input type="radio"/>

Troubleshooting

Problem	Possible Cause	Solution
No output	AC input and output circuit breakers are off	Turn on input and output circuit breakers
	No line power input	Turn on AC input breaker
	Red LED illuminates solid on front panel, indicating fault	Read fault event under Event Log in LCD display. Manually restart UPS. Contact Tripp Lite if fault persists.
Output LED is off	Line power or battery power is not available	Apply qualified input power and make sure battery and input breakers are turned on
	UPS fault	Contact Tripp Lite for repair information
UPS does not transfer to battery mode during a power failure or backup time is shorter than expected	Battery is not connected	Connect batteries (48V or 24V DC nominal)
	Battery circuit breaker is off	Turn on battery breaker
	Battery is not fully charged	Recharge the battery and then test discharge time
	Dead battery	Replace with new batteries
	UPS fault	Return to repair center
Alarm LED is lit	Abnormal conditions are detected	Solve the problem according to alarm information
Batteries will not charge	Battery circuit is open	<ol style="list-style-type: none"> 1. Check if the battery cable is connected firmly and make sure battery connection is correct. If there is any connection error, loosening or opening the connection will cause the circuit to open. 2. Check if proper battery voltage is detected on the UPS battery connector. 3. Check if the battery breaker is closed. 4. If the battery is bad, replace it.
	Wrong or bad temperature probe connected	Only use a factory-supplied temperature probe reading approximately 15,000 Ohms @ 25°C (77°F)
LCD text is not readable	UPS fault	Return to repair center
Password access is not available	Password is lost or forgotten	Contact Tripp Lite for resetting the new password

Battery Backup Time

Model SMART1524ET

Operating Temp Max Wattage Output	Load (Watt)	Configuration: 2x RBC12V100ET wired in a series configuration for a 24V 100Ah battery system	Configuration: 4x RBC12V100ET wired in a series-parallel configuration for a 24V 200Ah battery system
		Backup Time @ 24V DC 100Ah (min.)	Backup Time @ 24V DC 200Ah (min.)
75°C to 80°C	150	692	1402
	300	352	742
	400	258	520
	600	154	341
	800	113	259
	900	89	203
	1000	80	184
55°C to 75°C	1050	76	176
	1200	69	163
-40°C to 55°C	1350	59	138
	1400	57	133
	1450	54	128
	1500	52	123
	1600	43	115

Operating Temp Max Wattage Output	Load (Watt)	Configuration: 2x RBC12V55ET wired in series configuration for a 24V 55Ah battery system	Configuration: 4x RBC12V55ET wired in series-parallel configuration for a 24V 110Ah battery system
		Backup Time @ 24V DC 55Ah (min.)	Backup Time @ 24V DC 110Ah (min.)
75°C to 80°C	150	364	1540
	300	196	393
	400	126	292
	600	88	176
	800	54	128
	900	49	113
	1000	47	98
55°C to 75°C	1050	35	93
	1200	30	74
-40°C to 55°C	1350	31	62
	1500	28	55
	1600	18	47

Battery Backup Time

Model SMART1548ET

Operating Temp Max Wattage Output	Load (Watt)	Configuration: 4x RBC12V100ET wired in a series configuration for a 48V 100Ah battery system.	Configuration: 8x RBC12V100ET wired in a series-parallel configuration for a 48V 200Ah battery system.
		Backup Time @ 48 V DC 100Ah (min.)	Backup Time @ 48V DC 200Ah (min.)
75°C to 80°C	160	1174	2348
	320	751	1581
	400	431	862
	640	331	760
	800	269	538
	960	221	508
	1000	212	487
55°C to 75°C	1120	189	435
	1200	122	355
-40°C to 55°C	1280	161	335
	1440	139	295
	1600	117	257

Operating Temp Max Wattage Output	Load (Watt)	Configuration: 4x RBC12V55ET wired in series configuration for a 48V 55Ah battery system	Configuration: 8x RBC12V55ET wired in series-parallel configuration for a 48V 110Ah battery system
		Backup Time @ 48V DC 55Ah (min.)	Backup Time @ 48V DC 110Ah (min.)
75°C to 80°C	160	882	1765
	320	421	842
	400	273	552
	640	188	377
	800	125	263
	960	117	234
	1000	95	221
55°C to 75°C	1120	84	184
	1200	75	161
-40°C to 55°C	1280	71	149
	1440	63	132
	1600	54	105

Internal Fan Replacement

Fan Replacement

Under normal conditions, the original fan installation will last several years. However, the internal fan assembly is replaceable.



CAUTION: The fan circuitry is not isolated from AC mains. Turn off power to the UPS prior to fan replacement. Fan replacement must be performed by qualified electrical service personnel.



ATTENTION: Before removing the fan assembly, note the fan orientation. For proper installation and connectivity, the replacement fan must remain in its original orientation.

- 6 Power UPS off. Remove the two screws that secure the fan panel to the UPS.

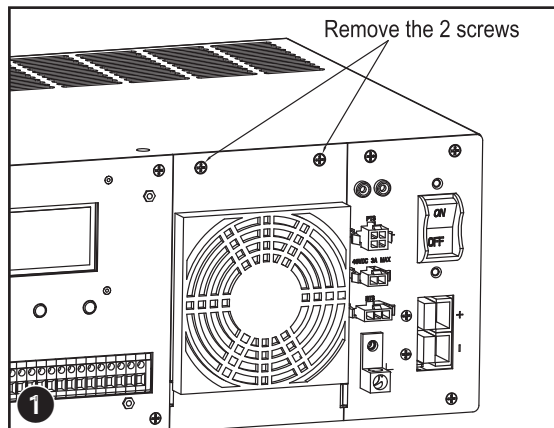

- 2 Remove the fan cover and fan filter, then slide the fan panel out and up carefully to remove it from the UPS, as the internal fan power cable is still attached to the UPS main board.

- 3 Disconnect the fan cable from the main board fan connector.

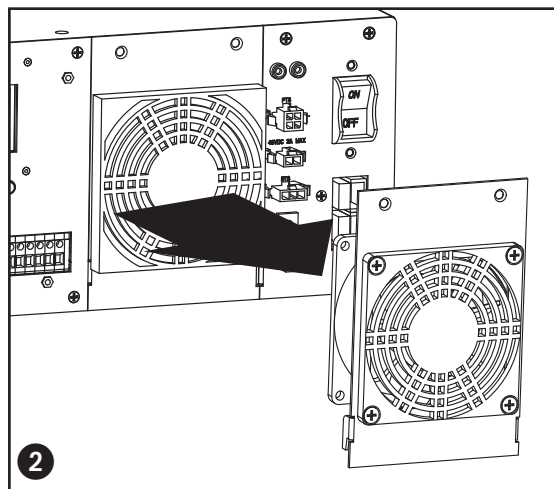

Internal Fan Replacement

- 4 Remove screws that secure the fan to the fan panel.
- 5 Install the replacement fan and secure it to the fan panel. Make sure to pay attention to its original orientation.
- 6 Attach the fan cable to the main board fan connector.
- 7 Reattach the fan panel back to the UPS.
- 8 Check operation of fan by powering ON the UPS system.

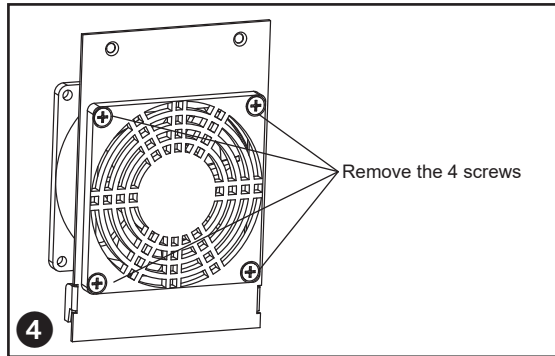

- 9 Secure fan panel back to the UPS with the screws removed in step 1.

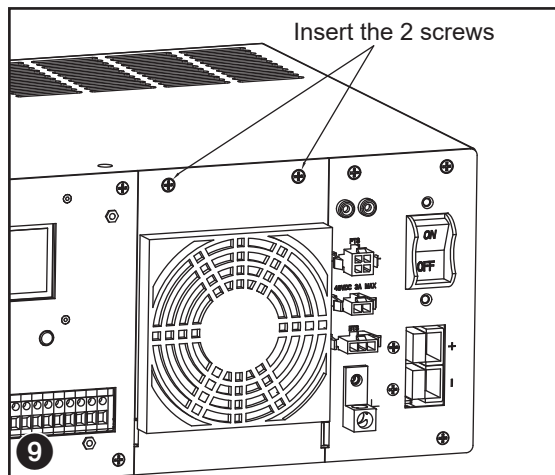
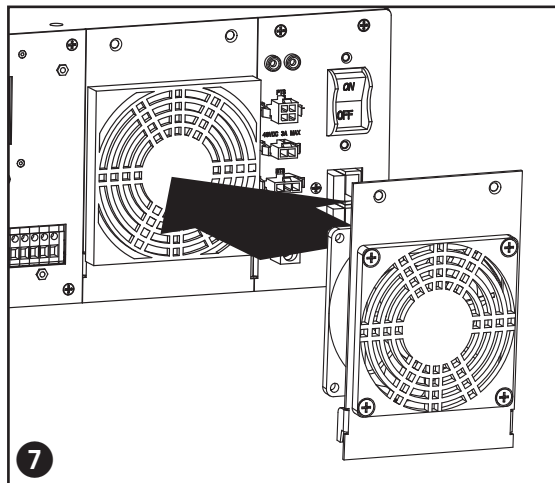

Internal Fan Replacement

Fan Filter Replacement

The internal fan is equipped with an air filter. To ensure proper operation, the filter should be checked periodically for debris or contaminants that would reduce the fan performance.

- 1 Use a small flat-head screwdriver to remove fan filter cover from front of UPS fan panel.
- 2 Clean filter cover.
- 3 Clean or replace fan filter with one of equivalent size and material type.

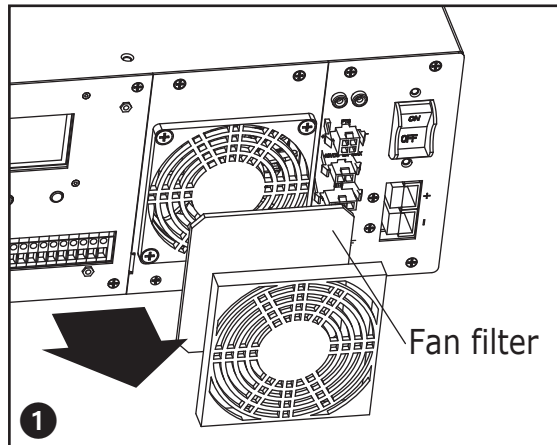

- 4 Reinstall filter cover.

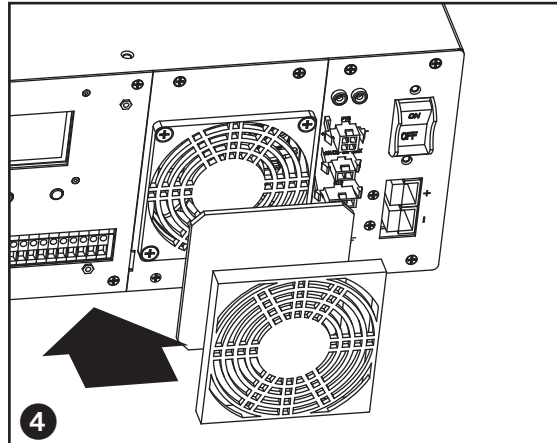

Storage and Service

Storage

To avoid battery drain, all connected equipment should be turned off and disconnected from the UPS. Press the power button and disconnect the unit from AC power. Your UPS will be completely turned off (deactivated) and will be ready for storage. If you plan on storing your UPS for an extended period, fully recharge the UPS batteries every 3 months. Plug the UPS into a live AC outlet, and allow the batteries to recharge for 4 to 6 hours. If you leave your UPS batteries discharged for a long period of time, they will suffer a permanent loss of capacity.

Service

A variety of Extended Warranty and On-Site Service Programs are available from Tripp Lite. For more information on service, visit tripplite.com/support.

Before returning your product for service, follow these steps:

1. Review the installation and operation procedures in this manual to ensure that the service problem does not originate from a misreading of the instructions.
2. If the problem continues, do not contact or return the product to the dealer. Instead, visit tripplite.com/support.
3. If the problem requires service, visit tripplite.com/support and click the Product Returns link. From here you can request a Returned Material Authorization (RMA) number, which is required for service. This simple on-line form will ask for your unit's model and serial numbers, along with other general purchaser information. The RMA number, along with shipping instructions, will be emailed to you. Any damages (direct, indirect, special or consequential) to the product incurred during shipment to Tripp Lite or an authorized Tripp Lite service center is not covered under warranty. Products shipped to Tripp Lite or an authorized Tripp Lite service center must have transportation charges prepaid. Mark the RMA number on the outside of the package. If the product is within its warranty period, enclose a copy of your sales receipt. Return the product for service using an insured carrier to the address given to you when you request the RMA.

Product Registration

Visit tripplite.com/warranty today to register your new Tripp Lite product. You'll be automatically entered into a drawing for a chance to win a FREE Tripp Lite product! *

* No purchase necessary. Void where prohibited. Some restrictions apply. See website for details.

Regulatory Compliance

FCC Part 68 Notice (United States Only)

If your Modem/Fax Protection causes harm to the telephone network, the telephone company may temporarily discontinue your service. If possible, they will notify you in advance. If advance notice isn't practical, you will be notified as soon as possible. You will be advised of your right to file a complaint with the FCC. Your telephone company may make changes in its facilities, equipment, operations or procedures that could affect the proper operation of your equipment. If it does, you will be given advance notice to give you an opportunity to maintain uninterrupted service. If you experience trouble with this equipment's Modem/Fax Protection, please visit triplite.com/support for repair/warranty information. The telephone company may ask you to disconnect this equipment from the network until the problem has been corrected or you are sure the equipment is not malfunctioning. There are no repairs that can be made by the customer to the Modem/Fax Protection. This equipment may not be used on coin service provided by the telephone company. Connection to party lines is subject to state tariffs. (Contact your state public utility commission or corporation commission for information.)

FCC Notice, Class A

This device complies with part 15 of the FCC Rules. Operation is subject to the following two conditions: (1) This device may not cause harmful interference, and (2) this device must accept any interference received, including interference that may cause undesired operation.

Note: This equipment has been tested and found to comply with the limits for a Class A digital device, pursuant to part 15 of the FCC Rules. These limits are designed to provide reasonable protection against harmful interference when the equipment is operated in a commercial environment. This equipment generates, uses, and can radiate radio frequency energy and, if not installed and used in accordance with the instruction manual, may cause harmful interference to radio communications. Operation of this equipment in a residential area is likely to cause harmful interference in which case the user will be required to correct the interference at his own expense.

WARNING: Changes or modifications not expressly approved by the party responsible for compliance could void the user's authority to operate the equipment.

Equipment Attachment Limitations (models with the Industry Canada label in Canada only)

NOTICE: The Industry Canada label identifies certified equipment. This certification means that the equipment meets the telecommunications network protective, operational and safety requirements as prescribed in the appropriate Terminal Equipment Technical Requirements Document(s). The Department does not guarantee the equipment will operate to the user's satisfaction. Before installing this equipment, users should ensure that it is permissible to be connected to the facilities of the local telecommunications company. The equipment must also be installed using an acceptable method of connection. The customer should be aware that the compliance with the above conditions might not prevent degradation of service in some situations.

Repairs to certified equipment should be coordinated by a representative designated by the supplier. Any repairs or alterations made by the user to this equipment, or equipment malfunctions, may give the telecommunications company cause to request the user to disconnect the equipment.

Users should ensure for their own protection that the electrical ground connections of the power utility, telephone lines and internal metallic water pipe system, if present, are connected together. This precaution may be particularly important in rural areas. Caution: Users should not attempt to make connections themselves, but should contact the appropriate electric inspection authority, or electrician, as appropriate.

Regulatory Compliance

Regulatory Compliance Identification Numbers

For the purpose of regulatory compliance certifications and identification, your Tripp Lite product has been assigned a unique series number. The series number can be found on the product nameplate label, along with all required approval markings and information. When requesting compliance information for this product, always refer to the series number. The series number should not be confused with the marking name or model number of the product.

Tripp Lite has a policy of continuous improvement. Product specifications are subject to change without notice. Photos and illustrations may differ slightly from actual products.



tripplite.com/support



23-05-123 93-397B_RevF