

Cuisinart®

Outdoor Grilling Products

OUTDOOR PREP TABLE

Model NO: CGWM-094

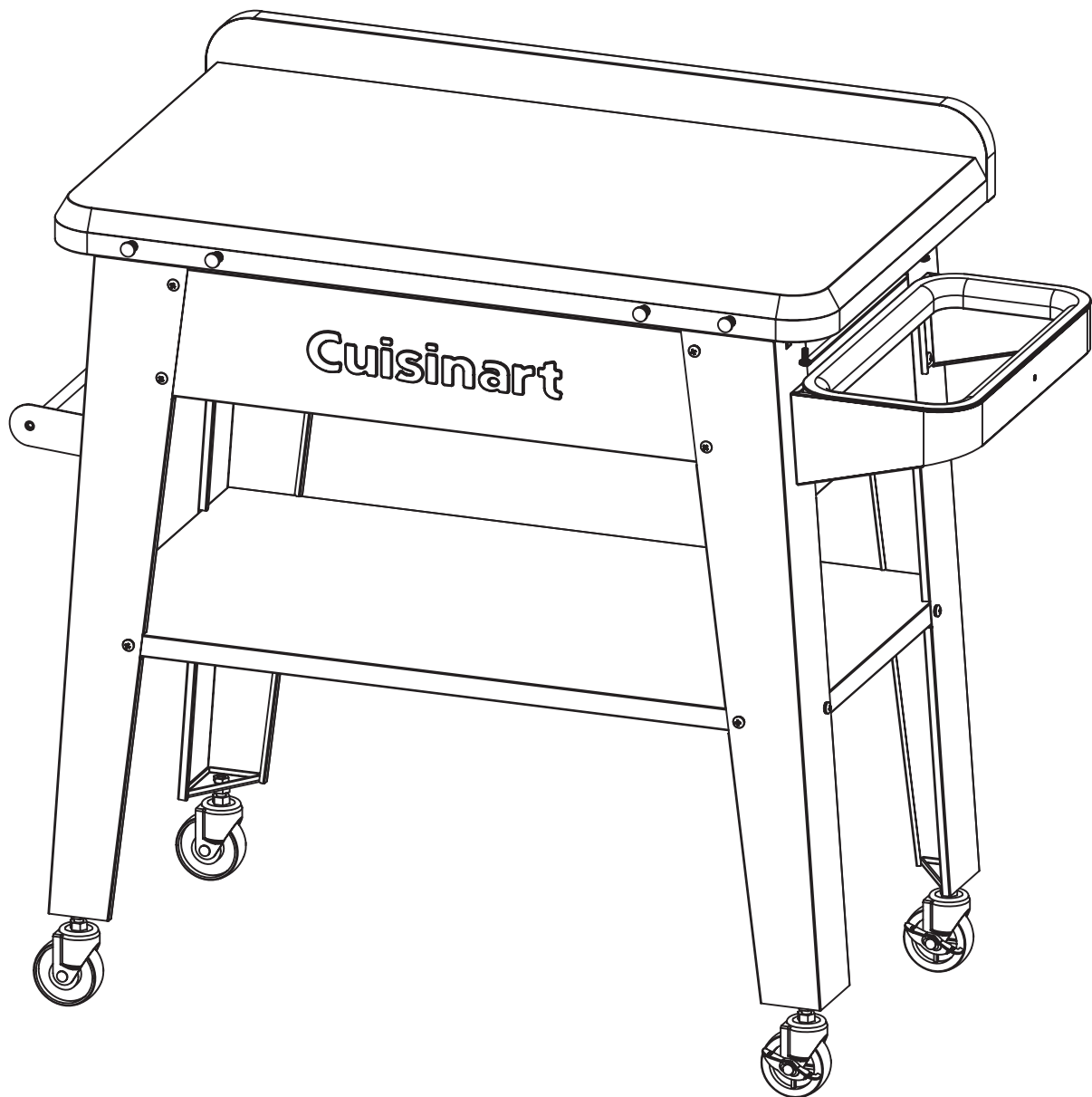

Customer Service Hotline

1-866-994-6390

DO NOT RETURN YOUR TABLE TO THE STORE

Before visiting your local retailer, call our customer service department at 1-866-994-6390 from 9:00 am to 5:00 pm Eastern time, Monday through Friday.

SAFETY INFORMATION

WARNINGS AND USAGE

IMPORTANT: ALL INSTRUCTIONS AND SAFEGUARDS IN THIS SECTION MUST BE FOLLOWED TO PREVENT DAMAGE AND/OR INJURY.



- Not for permanent installation.
- For outdoor use only
- Use caution with all electric appliances, tools, extension cords and lights on and around table.
- Surface can become hot in direct sun or high temperatures.
- Maximum top weight load of 50 LBS
- Maximum shelf weight load of 30 LBS
- Use only on level surfaces.
- Before use ensure wheels are height adjusted so that the table does not rock when in use.
- Lock wheels when in use.
- Do not allow children to climb the product.

CALIFORNIA PROPOSITION 65 WARNING:

- **WARNING: This product can expose you to lead, which is known to the State of California to cause cancer and birth defects or other reproductive harm. For more information go to www.P65Warnings.ca.gov**

CARE AND MAINTENANCE

CLEANING

Painted and Plastic surfaces

Wash with mild detergent or non-abrasive cleaner and warm water.













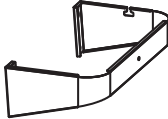
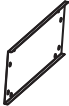

Stainless steel surfaces

Wash with mild detergent and warm soapy water or use a stainless steel cleaner. Wipe dry with a soft cloth after each use. Wash only in the direction of the stainless brushed finish to avoid damage.

Stainless steel can rust under certain conditions. This can be caused by acidic marinades, chlorine, saltwater, exposure to coastal climates, other natural elements, or improper cleaning tools such as wire or steel wool.

WHAT'S IN THE BOX

COMPONENTS

PART		DESCRIPTION	QTY	PART		DESCRIPTION	QTY
1		Counter Top Assembly	(x1)	9		Garbage Bag Ring	(x1)
2		Tool Hook	(x4)	10		Garbage Bag Support	(x1)
3		Side Panel	(x2)	11		Rear Support	(x1)
4		Left Back Leg (LB)	(x1)	12		Name Plate	(x1)
5		Left Front Leg (LF)	(x1)	13		Shelf	(x1)
6		Paper Towel Bar	(x1)	14		Right Back Leg (RB)	(x1)
7		Towel Bar End	(x2)	15		Right Front Leg (RF)	(x1)
8		Non-Locking Caster	(x2)	16		Locking Caster	(x2)

HARDWARE AND TOOLS

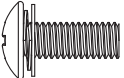
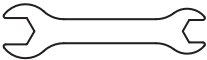
AA		Screw	(x32)	BB		Wrench	(x1)
----	---	-------	-------	----	--	--------	------

EXPLODED VIEW

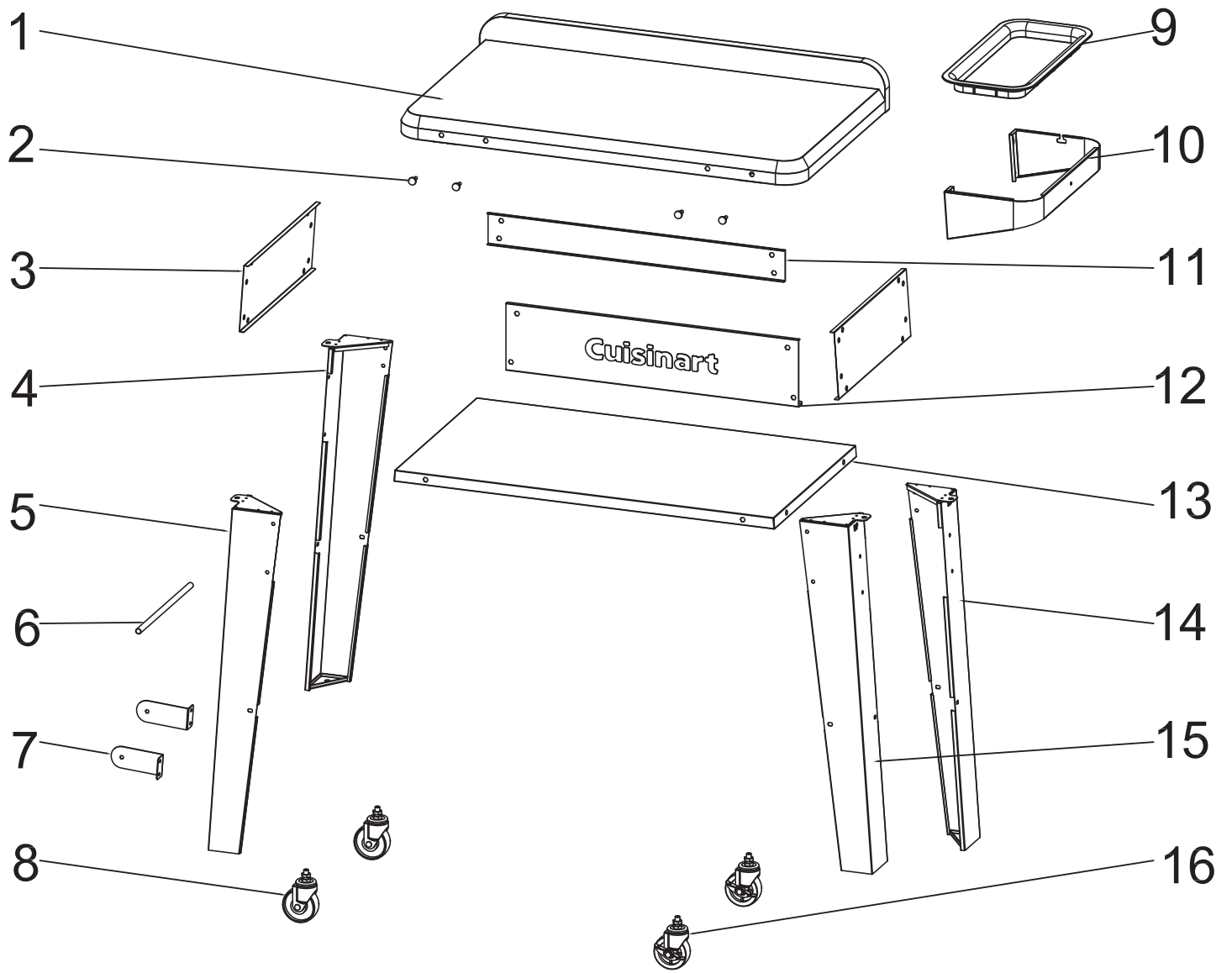

ASSEMBLY PREPARATION

Please be careful when handling components. Always wear work gloves during assembly and set up. Read and follow all safety statements, warnings, assembly instructions and use and care instructions before attempting to assemble and use. Before beginning assembly of product, make sure all parts are present. Compare parts with package contents list and hardware contents list. If any part is missing or damaged, DO NOT attempt to assemble the product.

Estimated Assembly Time: 1 hour

Tools required for assembly: (included) Wrench, (not included) Phillips Head Screwdriver (magnetic tip will be helpful), Gloves

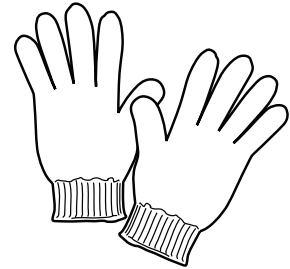
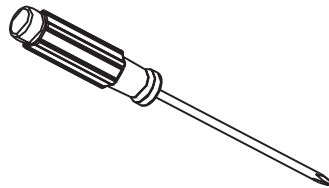
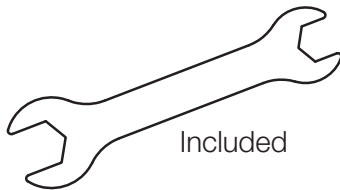

ASSEMBLY INSTRUCTIONS

Assembly Tip: To avoid scratching prep table and to protect floor/patio surfaces, reuse cardboard packaging and lay parts on top while assembling.

STEP 1

To create "screw assemblies" for future steps, install all 40 of the lock washers (BB) onto all 40 screws (AA).

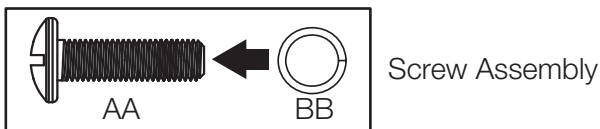

Install locking casters (16) and non locking casters (8) on opposing ends as shown. Use the double-ended open wrench (BB) to attach the 4 casters (16, 8) onto the bottom of each leg.

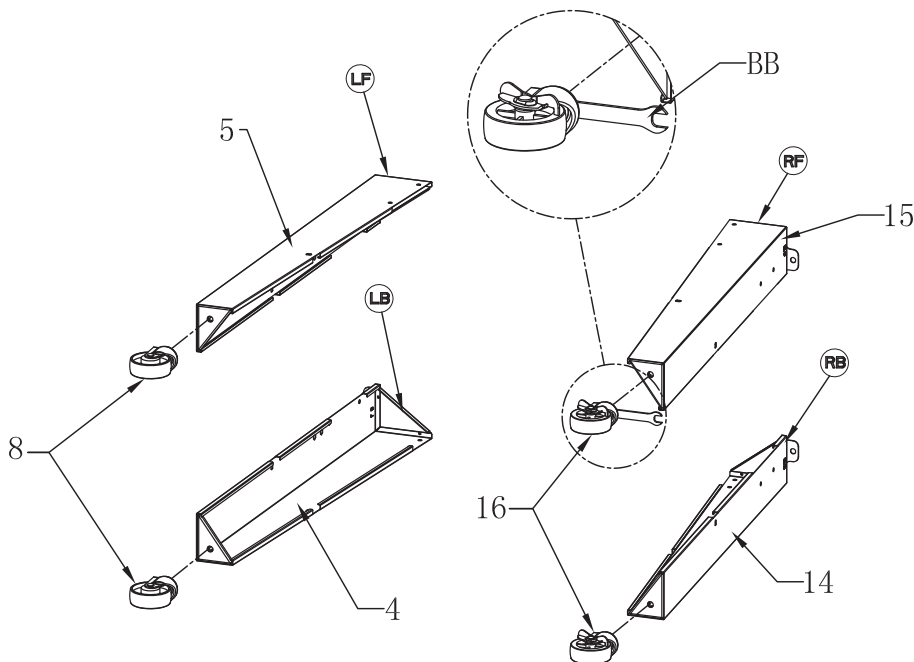

ASSEMBLY INSTRUCTIONS

STEP 2

Use screw assemblies to attach the middle portion of left back leg (4) (LB) and the right back leg (14) (RB) to the shelf (13) as shown below.

- **Note: it is important to not fully tighten the screws during initial assembly of the parts. Wait until the counter top assembly is installed before fully tightening all screws on the cart.**
- **Note: Legs are punched with markings to indicate position for assembly, (LB, RB, LF, RF).**

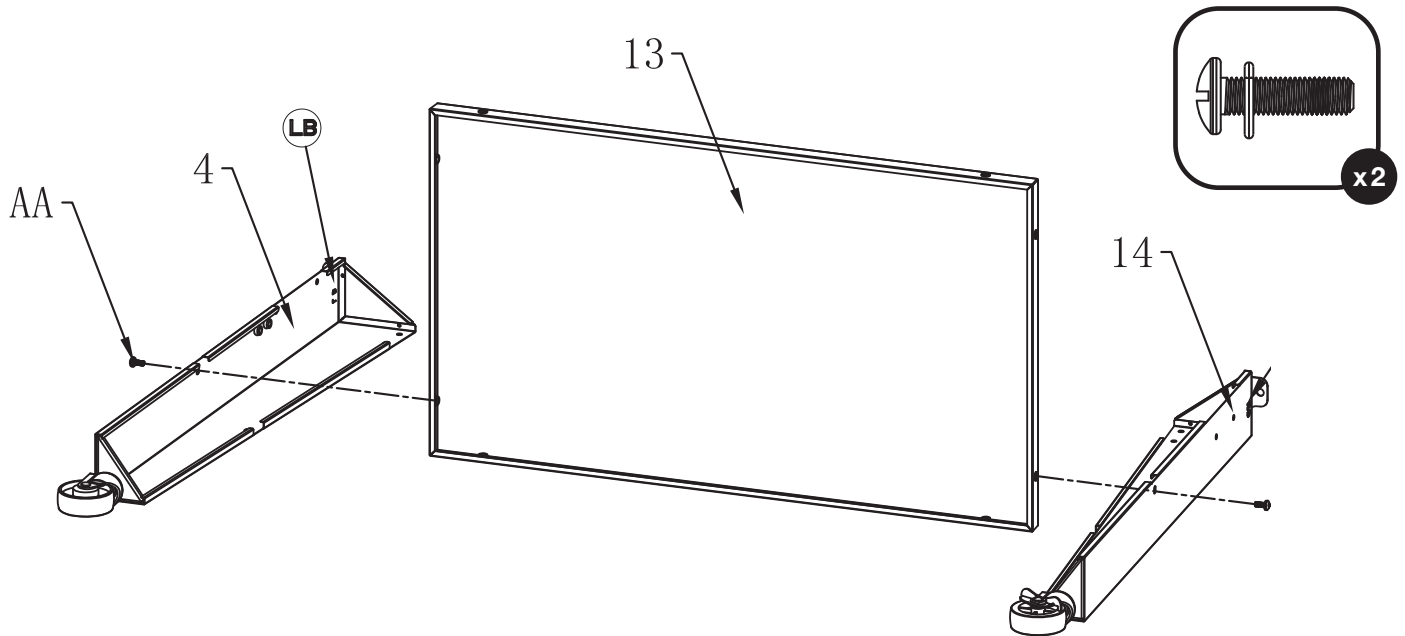

STEP 3

Use screw assemblies to attach the left front leg (5) (LF) and the right front leg (15) (RF) to the shelf (13).

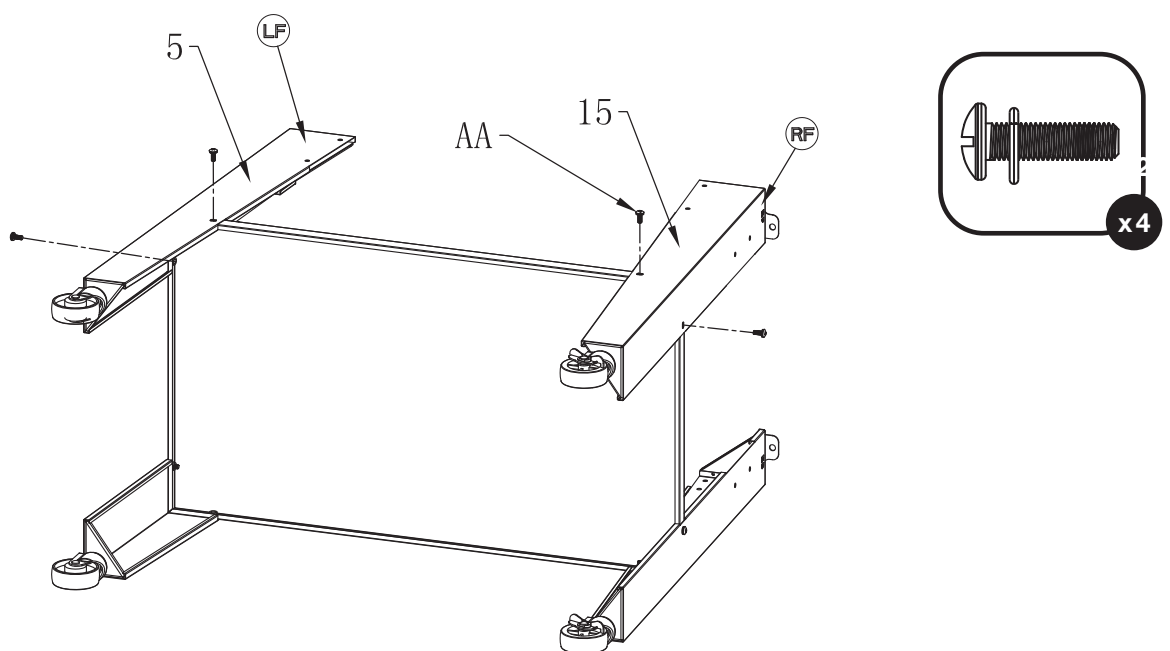

ASSEMBLY INSTRUCTIONS

STEP 4

Use screw assemblies to attach side panels (3) to the left and right leg assemblies using four screws for each).

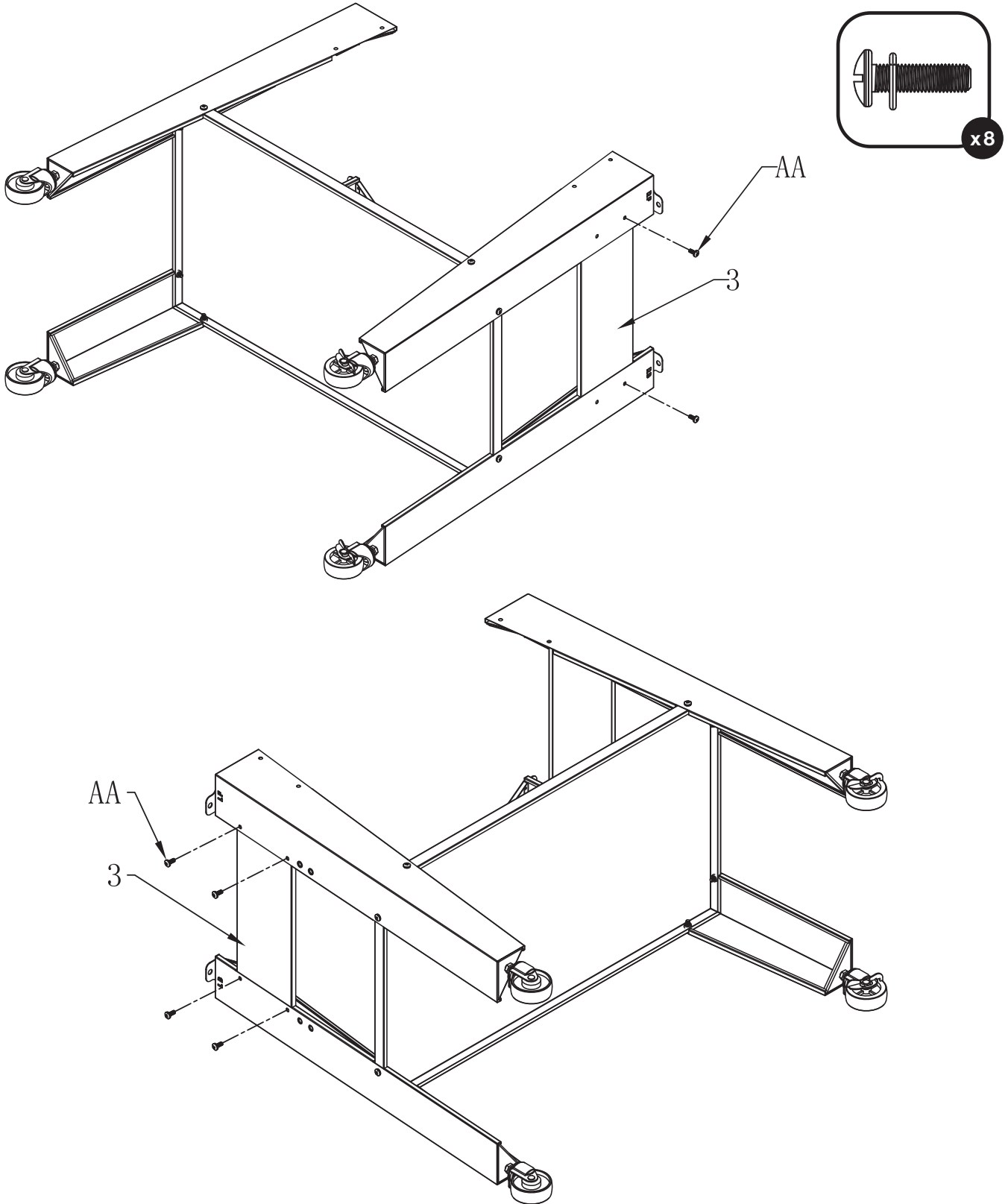

ASSEMBLY INSTRUCTIONS

STEP 5

Use screw assemblies to attach name plate (12) to the left front leg (5) (LF) and the right front leg (15) (RF). Next use screw assemblies to attach the rear support (11) to the left back leg (4) (LB) and the right back leg (14) (RB).

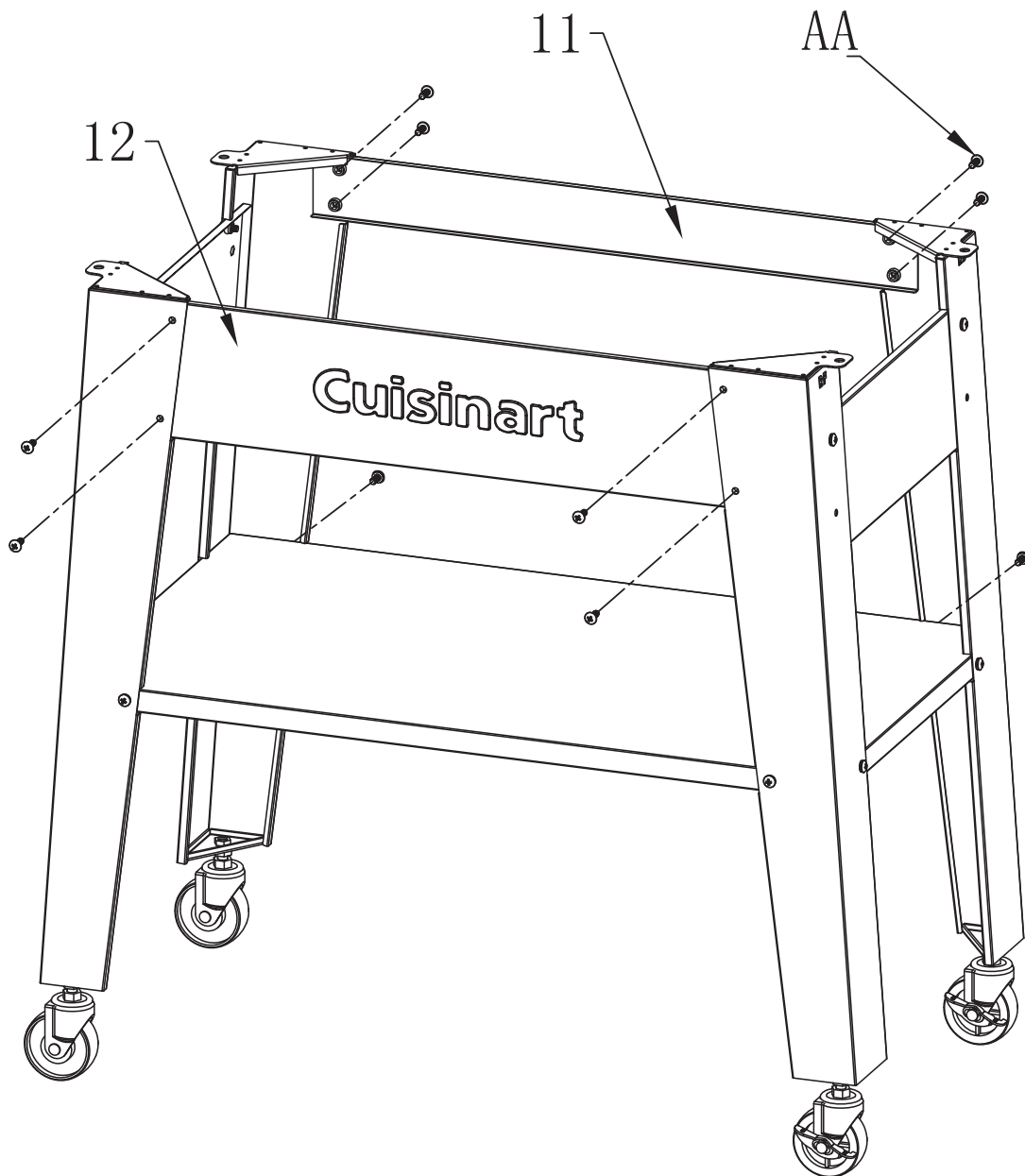
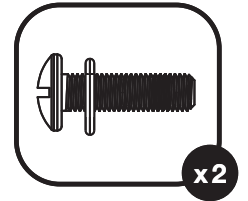

ASSEMBLY INSTRUCTIONS

STEP 6

Use screw assemblies to attach the garbage bag support (10) to the right leg assembly using the two previously installed screws and the slotted upper holes. Then install two screws in the lower holes to secure in place.

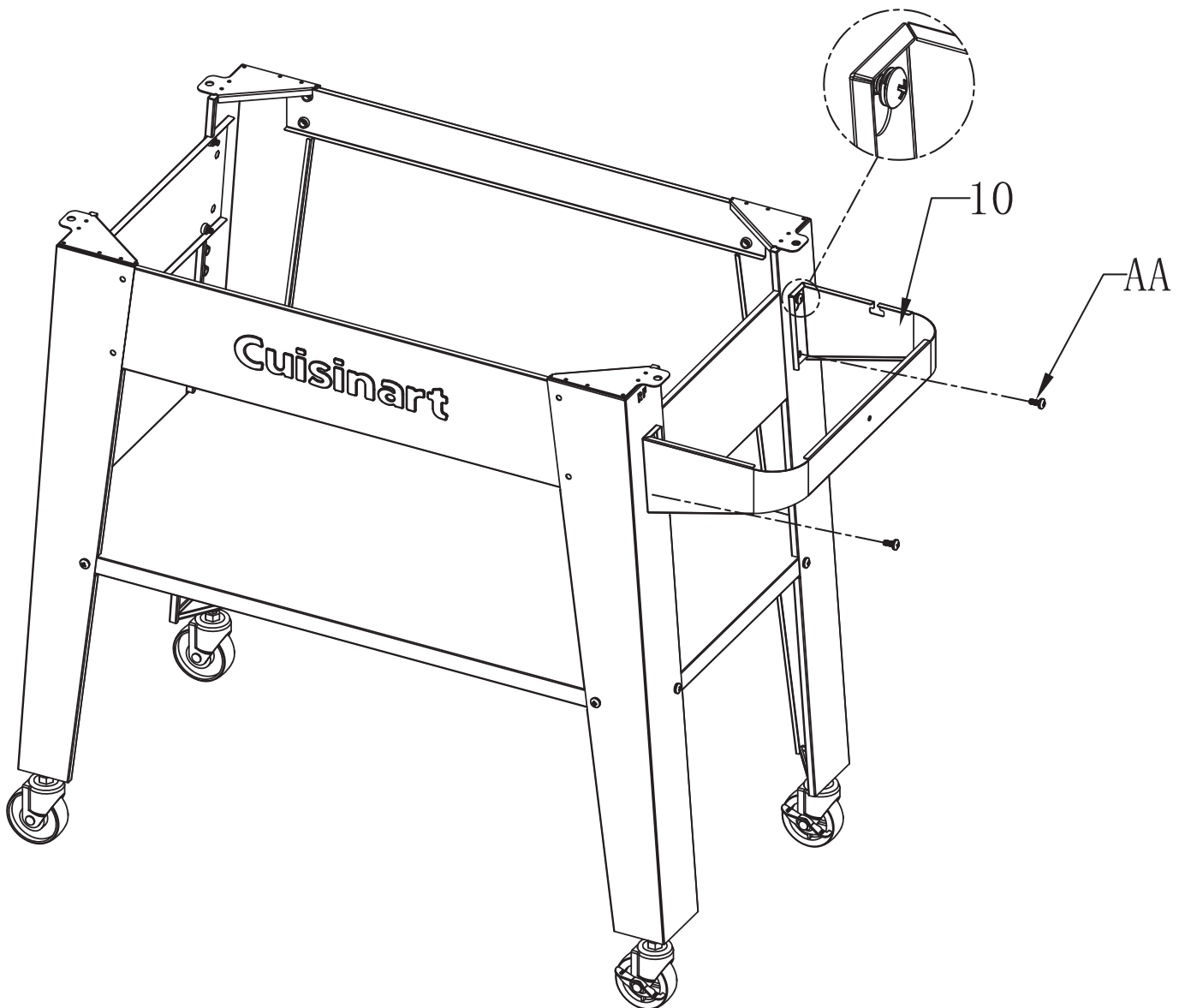
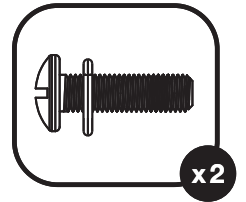

ASSEMBLY INSTRUCTIONS

STEP 7

Use screw assemblies to attach both of the towel bar ends (7) to the left leg assembly.

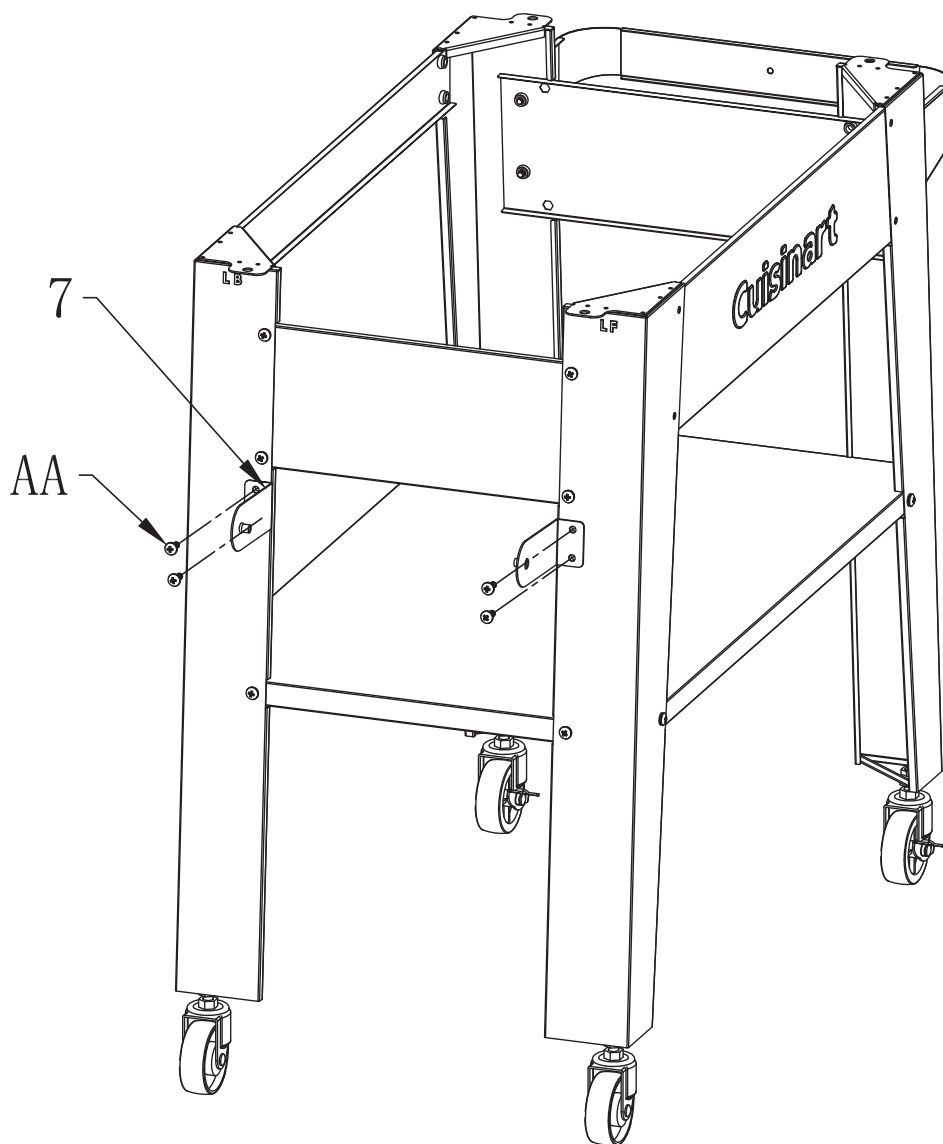
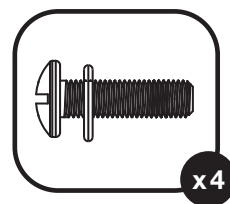

STEP 8

Install the paper towel bar (6) between the two towel bar ends (7) by flexing them slightly outward inserting bar and releasing.

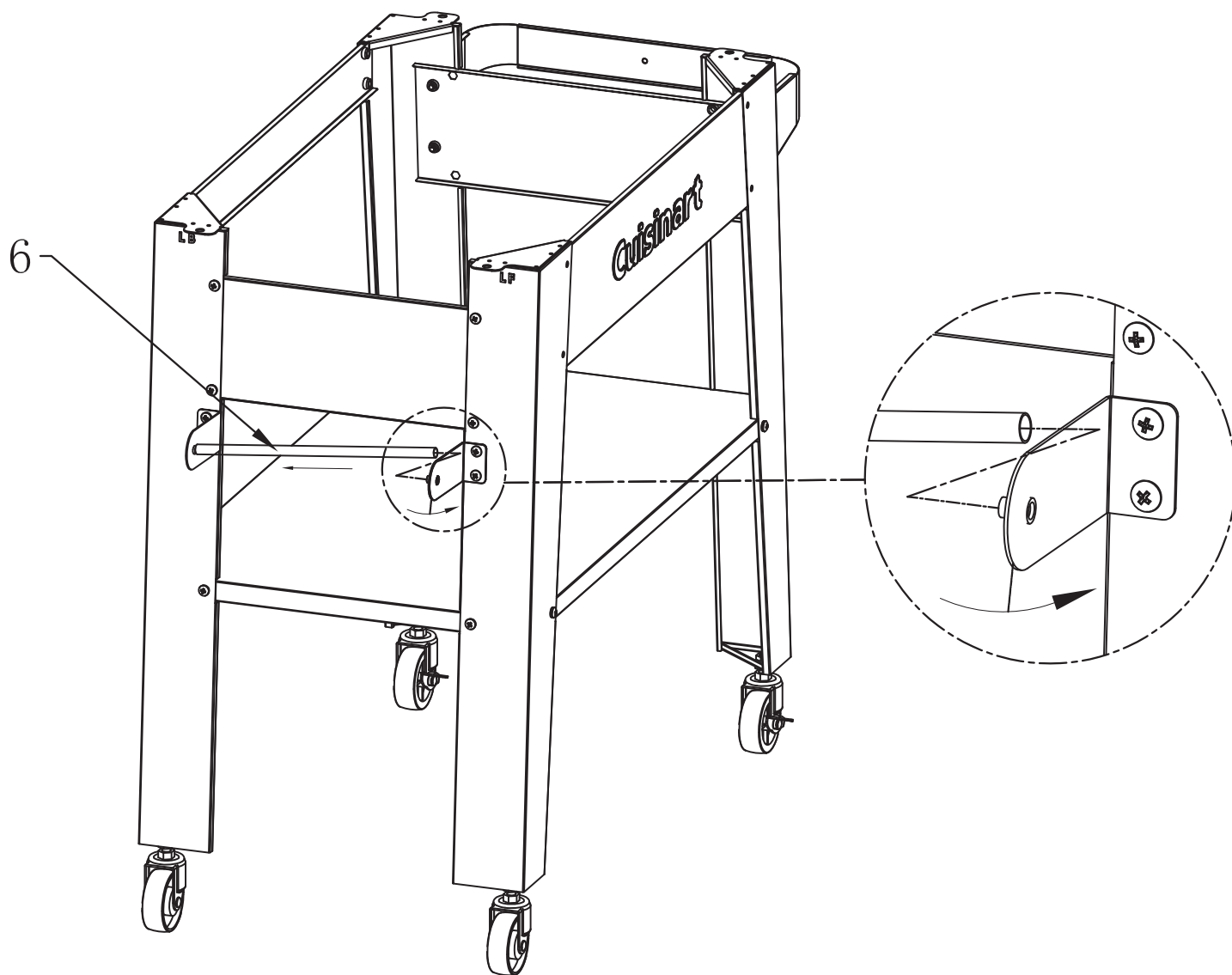

ASSEMBLY INSTRUCTIONS

STEP 9

Use screw assemblies to attach the counter top assembly (1) to the prep station base. **Now tighten all screw assemblies that have been installed throughout the unit.**

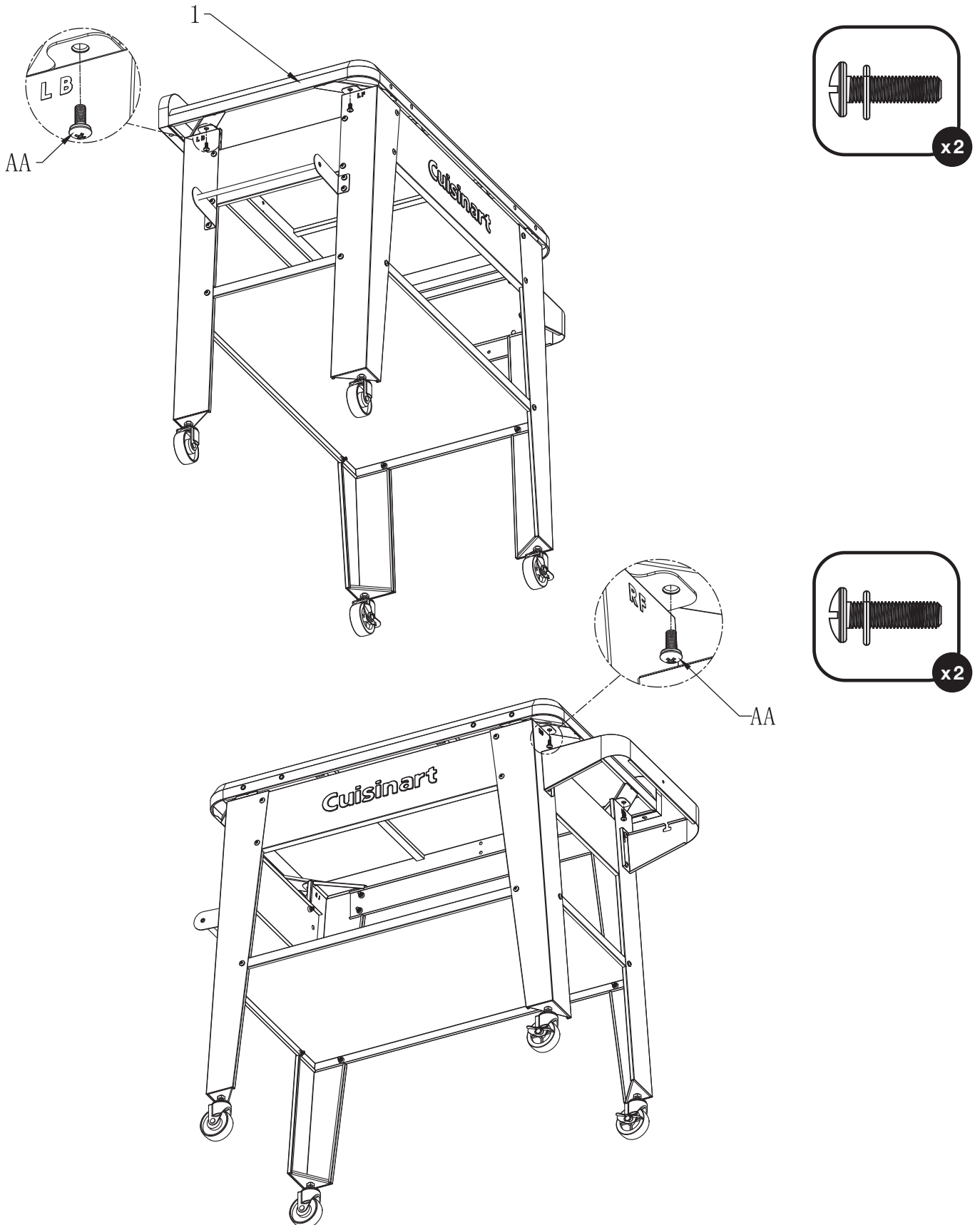

STEP 10

Install the tool hooks (2) by screwing them into the front edge of the counter top assembly (1). Place the garbage bag ring (9) into the garbage bag support (10).

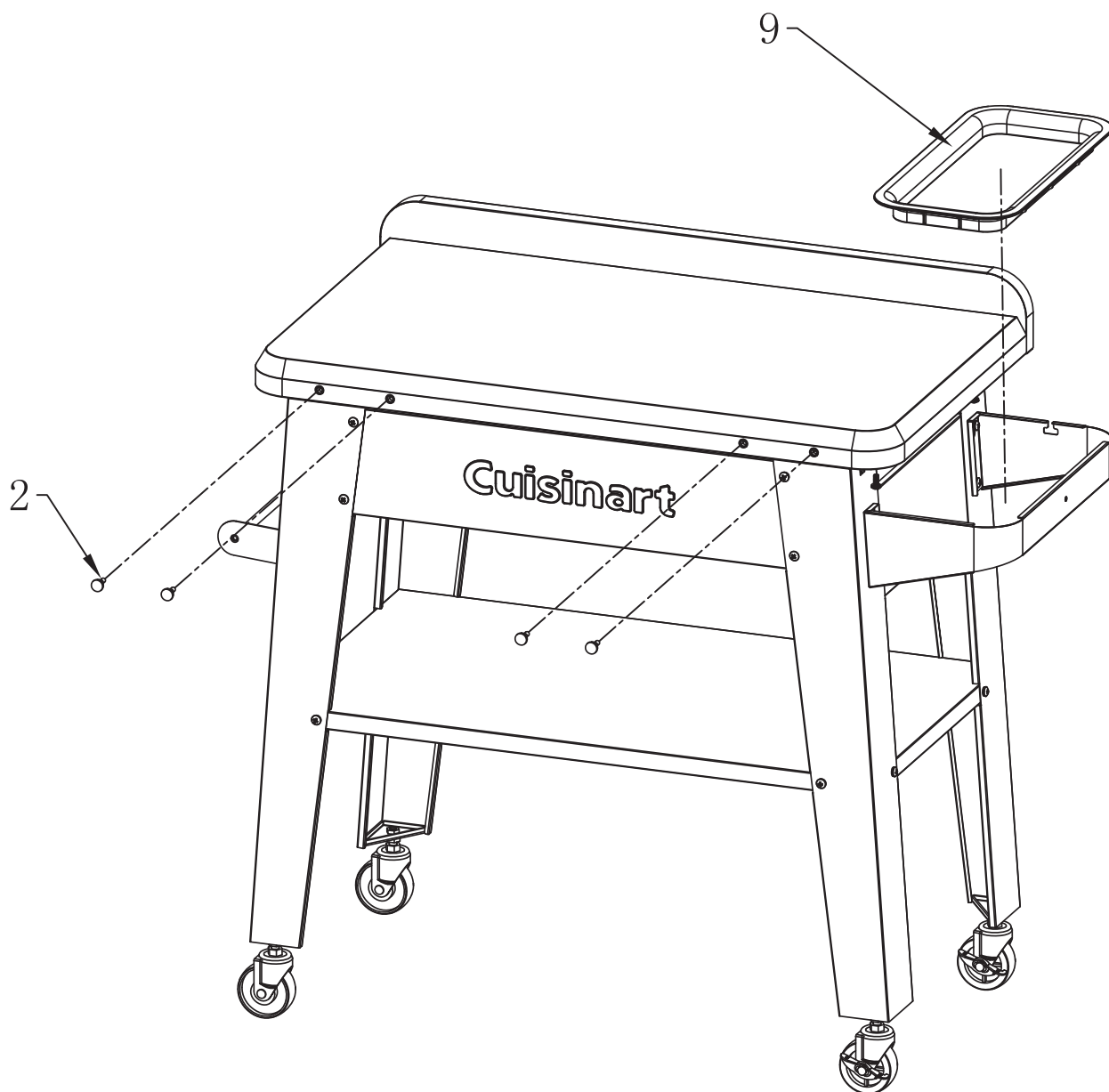

STEP 11

Once the completed prep table is in its' desired location use the threaded posts of the casters (8, 16) to level the table and lock nuts with the double-ended open wrench (BB) to hold the adjusted position.

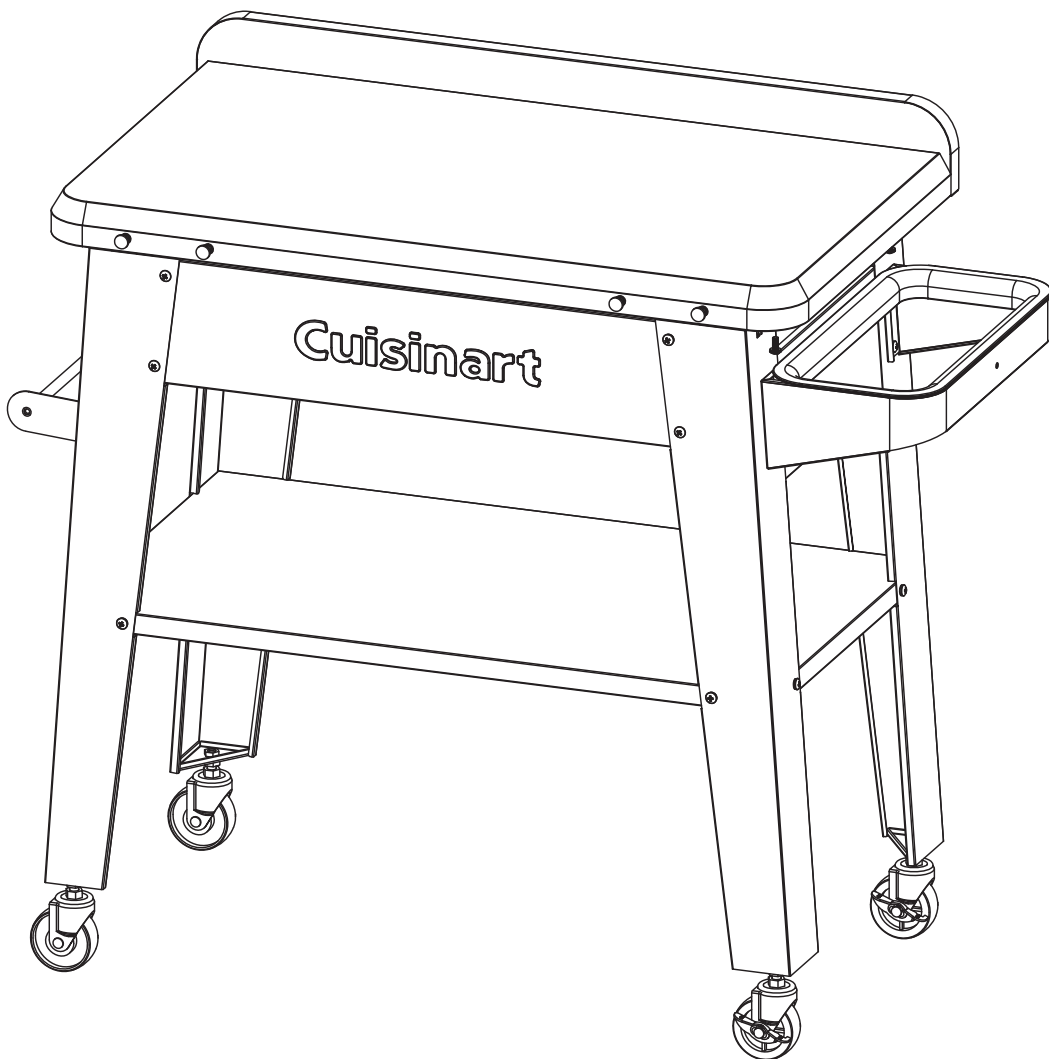

GARBAGE BAG INSTRUCTIONS

STEP 18

Install a garbage bag by inserting the bag through the garbage bag ring (9) and then wrapping the open end of the bag around the ring. Feed the bottom of the bag through the garbage bag support (10) and then place the garbage bag ring (9), with the opening of the bag wrapped around it, into the garbage bag support (10).

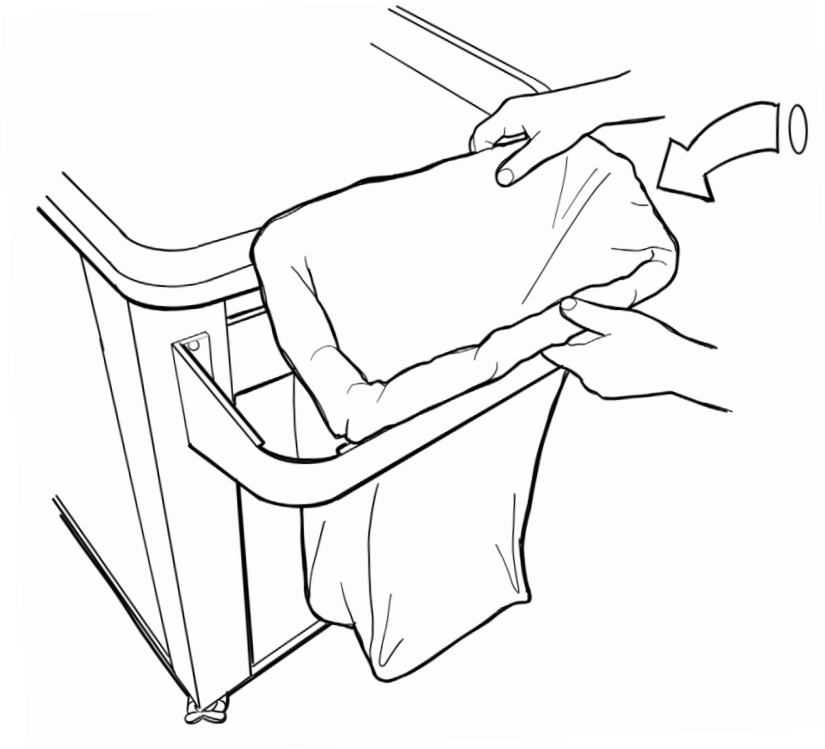

STEP 19

Pull the bag from its' bottom to ensure it is fully secured by the garbage bag ring (9) and garbage bag support (10).

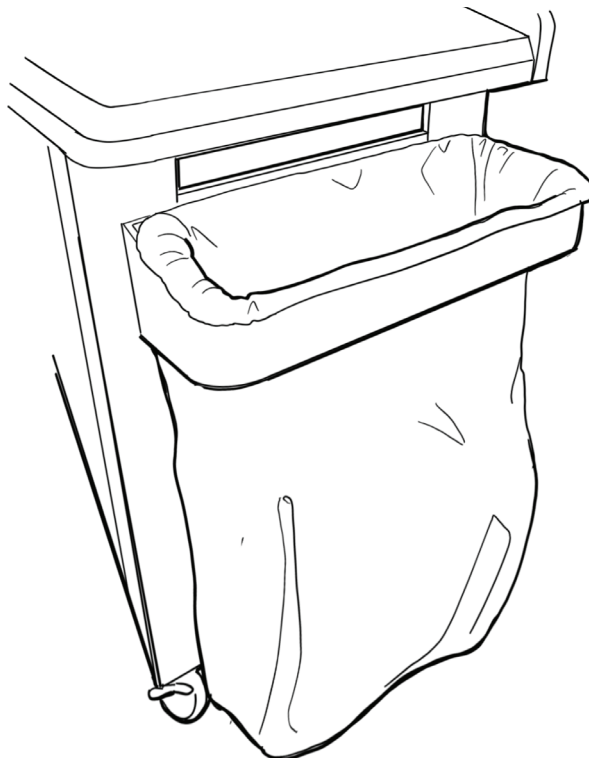

WARRANTY AND REPLACEMENT PARTS

1 Year Limited Warranty

PROOF OF PURCHASE is required to access this warranty program, which is in effect from the date of purchase. Customers will be subject to parts, and shipping and handling fees if unable to provide proof of the purchase or after the warranty has expired.

If you have any questions or problems, you can call our customer service department at 1-866-994-6390 from 9:00am to 5:00pm EST, Monday through Friday for assistance.

This limited warranty applies to the functionality of the product ONLY. It does not cover cosmetic issues such as scratches and dents, damage from abrasive or chemical cleaners or any tools used in the assembly or installation of the table, surface rust, or the discoloration of stainless steel surfaces. Paint is not warranted and will require touch up. RUST is not considered a manufacturing or materials defect.

This limited warranty will not reimburse you for the cost of any inconvenience, food, personal injury or property damage.

WARRANTY PROVISIONS

This warranty is non-transferable and does not cover failures due to misuse, improper installation or maintenance.

This warranty is for replacement of defective parts only. We are not responsible for incidental or consequential damages or labor costs.

This warranty does not cover corrosion or discoloration after the prep table is used, or lack of maintenance, hostile environment, accidents, alterations, abuse or neglect.

This warranty does not cover damage caused by abrasive or chemical cleaners, or any damage to other components used in the installation or operation of the prep table.

Paint is not warranted and may require touch-up.

DISCLAIMER OF IMPLIED WARRANTIES; LIMITATION OF REMEDIES

Repair or replacement of defective parts is your exclusive remedy under the terms of this limited warranty. Manufacturer will not be responsible for any consequential or incidental damages arising from the breach of either this limited warranty or any applicable implied warranty, or for failure or damage resulting from acts of God, improper care and maintenance, accident, alteration, replacement of parts by anyone other than manufacturer, misuse, transportation, commercial use, abuse, hostile environments (inclement weather, acts of nature, animal tampering), improper installation or installation not in accordance with printed manufacturer instructions.

For replacement parts, call our customer service department at 1-866-994-6390 from 9:00am to 5:00pm EST, Monday through Friday for assistance.

To register your Cuisinart product, please visit <https://cuisinart.registria.com>.

For FAQ's and replacement parts, please contact us at grilling@thefulhamgroup.com.

For our consumer care department, please contact us at grilling@thefulhamgroup.com or call 1-866-994-6390.

Model # CGWM-094
North American Distributor:
The Fulham Group
Newton, MA 02466