



# COMMERCIAL ELECTRIC POPCORN POPPERS

## Operating Instruction Manual



POP-8B



POP-8R

### Optional Accessories



POP-8RC



POP-8RC-D



POP-8RC	Popcorn Cart for POP-8R
POP-8RC-D	Golden "POPCORN" Decal

Model	Voltage	Frequency	Power	Amperage	Plug Type	Overall Dimensions			Weight
						Length	Depth	Height	
POP-8B	120V	60Hz	1130W	9.5A	NEMA 5-15P	17-3/4" (450mm)	14-3/4" (375mm)	23-1/2" (597mm)	30.86 lbs 14 kgs
POP-8R			1350W	12A	NEMA 5-15P	22" (559mm)	16-1/2" (420mm)	30" (762mm)	48.5 lbs 22 kgs

### BEFORE OPERATING ANY EQUIPMENT, READ AND FAMILIARIZE YOURSELF WITH THESE USE AND SAFETY INSTRUCTIONS

*Congratulations on your purchase of this WINCO® commercial equipment. WINCO takes pride in the quality of its products. When used as intended and with proper care and maintenance, you will experience years of reliable operation from this equipment. To ensure best results, it is important that you read and follow the instructions in this manual carefully. It's important to save these instructions for future reference.*

## Commercial Popcorn Popper

### Important For Future Reference

Please complete this information and retain this manual for the life of the product. For Warranty Service and/or parts, this information is required. Please see Page 8 for More information on your Warranty and how to register.

Model Number

Serial Number

Date Purchased



**WARNING: IMPROPER INSTALLATION, ADJUSTMENT, ALTERATION, SERVICE OR MAINTENANCE CAN CAUSE PROPERTY DAMAGE, INJURY, OR DEATH. READ THE INSTALLATION, OPERATION, AND MAINTENANCE INSTRUCTIONS THOROUGHLY BEFORE INSTALLING OR SERVICING THIS EQUIPMENT.**

**AVERTISSEMENT: TOUTE INSTALLATION, RÉGLAGE, MODIFICATION, RÉPARATION OU ENTRETIEN INCORRECT PEUT OCCASIONNER DES DOMMAGES MATÉRIELS, DES BLESSURES GRAVES OU LA MORT. LIRE LES INTRUCTIONS D'INSTALLATION, D'UTILISATION ET D'ENTRETIEN ATTENTIVEMENT AVANT D'INSTALLER OU DE RÉPARER CET APPAREIL.**



**CAUTION: THESE MODELS ARE DESIGNED, BUILT, AND SOLD FOR COMMERCIAL USE ONLY. IF THESE MODELS ARE POSITIONED SO THE GENERAL PUBLIC CAN USE THE EQUIPMENT, MAKE SURE THAT CAUTION SIGNS, WARNINGS, AND OPERATING INSTRUCTIONS ARE CLEARLY POSTED NEAR EACH UNIT SO THAT ANYONE USING THE EQUIPMENT WILL USE IT CORRECTLY AND NOT INJURE THEMSELVES OR HARM THE EQUIPMENT.**

**ATTENTION: CES MODÈLES SONT CONÇUS, FABRIQUÉS, ET VENDUS POUR UN USAGE COMMERCIAL SEULEMENT. SI CES MODÈLES SONT PLACÉS POUR QUE LE GRAND PUBLIC PUISSE LES UTILISER, ASSUREZ-VOUS QUE LES CONSIGNES D'ATTENTION, D'AVERTISSEMENT, ET LES INSTRUCTIONS D'UTILISATION SOIENT CLAIEMENT AFFICHÉES PRÈS DE CHAQUE UNITÉ DE SORTE QUE N'IMPORTE QUEL UTILISATEUR DE L'APPAREIL L'EMPLOIE CORRECTEMENT ET NE SE BLESSE PAS OU N'ENDOMMAGE PAS L'APPAREIL.**



**WARNING: A FACTORY AUTHORIZED SERVICE PROVIDER SHOULD HANDLE ALL MAINTENANCE AND REPAIR. BEFORE DOING ANY MAINTENANCE OR REPAIR, FOLLOW SERVICE SET UP ARRANGEMENT ON PAGE 8.**

**AVERTISSEMENT: UN TECHNICIEN AUTORISÉ PAR L'USINE DEVRA EFFECTUER TOUT L'ENTRETIEN ET LES RÉPARATIONS. AVANT DE FAIRE TOUT ENTRETIEN OU RÉPARATION, VEUILLEZ CONTACTER WINCO.**



## Introduction

Congratulations on the purchase of your WINCO® machine. Please take the time to carefully read through this manual to ensure the machine is operated and maintained properly, to ensure the best possible performance from this product for many years.

WINCO will not accept liability if:

- The instructions in this manual have not been followed correctly.
- Non-authorized personnel have tampered with the machine.
- Non-original spare parts are used.
- The machine has not been handled and cleaned correctly.
- There is any use damage to the unit.

## Commercial Popcorn Popper

### Table of Contents

Specifications .....	1
Warnings .....	2
Introduction .....	2
Packaging .....	3
Important Safeguards.....	4
Operation .....	5
Cleaning, Care & Maintenance .....	6
Safety .....	6
Assembly Instructions for Popcorn Cart .....	7
Exploded Diagram .....	8
Parts List.....	9
Electrical Diagram .....	9
Troubleshooting .....	10
Service & Repair .....	10
Limited Warranty .....	11

### Package Contents

All units come with an Operating Instruction Manual and the following:

- POP-8B or POP-8R

WINCO prides itself on quality and service, ensuring that at the time of packing, all products are supplied fully functional and free of damage. Should you find any damage as result of freight, please contact your WINCO dealer immediately.

### Function and Purpose

This unit is intended to be used in commercial food-service operations only. It is not intended for household, industrial or laboratory use.

### NOTE

***Please remember that this manual and the warning labels do not replace the need to be alert, to properly train and supervise operators, and to use common sense when using this equipment.***

### Unpacking the Equipment

#### **DISPOSE OF ALL PACKAGING MATERIALS IN AN ENVIRONMENTALLY RESPONSIBLE MANNER.**

1. Remove all packing materials and tape, as well as any protective plastic and cardboard, from the unit.
2. Clean any glue residue left over from the plastic or tape.
3. Place the unit in the desired position and height.

**SAVE THE ORIGINAL BOX AND PACKAGING FOR USE IN PACKAGING AND SHIPPING THE EQUIPMENT IF SERVICES ARE NEEDED.**

## Important Safeguards

These instructions should be followed at all times. Failure to follow these instructions could result in injury to yourself and others.

### WHEN USING ELECTRICAL APPLIANCES, BASIC SAFETY PRECAUTIONS AND COMMON SENSE SHOULD BE FOLLOWED, INCLUDING BUT NOT LIMITED TO THE FOLLOWING:

1. Read all instructions carefully. Do not use this appliance for anything other than its intended use.
2. DO NOT touch any surfaces that may be hot.
3. Unplug from outlet when not in use prior to installing or removing parts and before cleaning. Allow for the device to cool first before handling.
4. To protect against the risk of electrical shock, do not immerse the appliance, cord or plug in water, or other liquids.

<b>WARNING ⚠️ AVERTISSEMENT</b>		
	<b>Electrical Shock Hazard</b> Keep water and other liquids from entering the inside of the unit. Liquid inside the unit could cause an electrical shock.	<b>Risque de choc électrique</b> Conserver l'eau et d'autres liquides de pénétrer à l'intérieur de l'appareil. Liquide à l'intérieur de l'appareil pourrait provoquer un choc électrique.
	Do not spray water or cleaning products. Liquid could contact the electrical components and cause a short circuit or an electrical shock. Do not use unit if power cord is damaged or has been modified.	Ne pas pulvériser de l'eau ou des produits de nettoyage. Le liquide pourrait contacter avec les composants électriques et causer un court-circuit ou un choc électrique. Ne pas utiliser l'appareil si le cordon d'alimentation est endommagé ou a été modifié.

5. DO NOT operate this device or any other electrical equipment with a damaged cord or plug, or after the unit malfunctions, is dropped or damaged in any manner. Return to the nearest WINCO Authorized Service Center for examination, repair and/or adjustment.
6. The use of accessory attachments not recommended by WINCO may cause fire, electric shock or injury.

<b>WARNING ⚠️ AVERTISSEMENT</b>		
	<b>Fire Hazard.</b> Correct installation precautions, procedures and regulations must be followed. Operation and safety training is necessary for all users of this equipment.	<b>Risque d'incendie</b> La surchauffe des vapeurs d'huile ou de l'huile peut s'enflammer et provoquer un incendie. Surveillez la température, la qualité et le niveau d'huile. Utilisez et entretenez le système d'élimination des vapeurs d'huile.

7. Not intended for outdoor installation.
8. DO NOT let the cord hang over the edge of a table or counter, or touch hot surfaces.
9. DO NOT place on or near a hot gas or electric burner, or in a heated oven.

10. This appliance should always be on a stable and steady countertop or table. Allow sufficient space around the cooking area. Never use the unit on/near low-heat-resistant materials (carpet, vinyl).
11. This appliance is not intended for use by individuals (including children) with reduced or impaired physical, sensory or mental capabilities, or lack of experience or knowledge, unless they have been given proper supervision or instruction concerning the use of this appliance by a person responsible for their safety.
12. Clean the heated popping kettle with caution – if a wet sponge or cloth is used to wipe spills on a hot cooking surface, exercise caution to avoid steam burns. NOTE: some cleaners may produce noxious flames when applied to a hot surface.
13. Do not place metal objects such as knives, forks or spoons, in the heated popcorn kettle as they can break the motor, get hot and/or cause injury.
14. Do not store any item on top of this unit when in operation.
15. Never place materials such as paper, cardboard, plastic, etc. on or under this unit.
16. If an extension cord power-supply is used,
  - a. The marked electrical rating of the extension cord should be rated the same or greater than the electrical rating of the unit.
  - b. The cord should be located so that it will not drape over the countertop or tabletop where it can not be damaged or moved unintentionally.

### Proper Grounding · Mise à la terre correcte

This machine is provided with a three-pronged grounding plug. The outlet to which this plug is connected must be properly grounded. If the receptacle is not the proper grounding type, contact an electrician. DO NOT, under any circumstances, cut or remove the third ground prong from the power cord or use any adapter plug.

*Cette machine est équipée d'une fiche à trois broches. La prise sur laquelle cette fiche est branchée doit être correctement mise à la terre. Si la prise n'est pas le type de mise à la terre, contactez avec un électricien. NE PAS, en aucun cas couper ou enlever la troisième broche de terre à partir du cordon d'alimentation ou utiliser un adaptateur.*

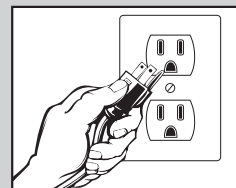

**USE A GROUNDED OUTLET  
DO NOT ADD AN ADAPTOR  
TO THE PLUG**

**UTILISER UNE PRISE AVEC MISE  
À LA TERRE NE PAS AJOUTER UN  
ADAPTEUR SUR LA FICHE**

## Operation

---

1. Plug in the power cord.
2. Make sure the kettle is installed in its upright and locked position, and there are no obstructions in the kettle.
3. Turn on the power, stirring motor and heater switch.
4. Allow kettle to preheat for 5 to 6 minutes.
5. Open the lid and pour in oil and seasonings.

### **WARNING**

**DO NOT add butter in kettle at any time while heating or when popcorn is popping.**

**If using butter, it should only be applied AFTER all kernels have popped and popcorn is removed from kettle.**

6. Add popcorn kernels and close lid.

**NOTE: Close the lid to prevent uncooked kernels and hot oil from ejecting out of the kettle.**

7. Popcorn will start popping, overflowing out of the kettle into the tray below.
8. Once popping has stopped, open the lid and turn kettle to dump out remaining popcorn (there may be some un-popped kernels).
9. Repeat steps 5 through 8 to make more as needed.

**NOTE: Power to the kettle must be turned off when it is not in use in order to maintain efficiency.**

## Cleaning & Maintenance

**Before using this equipment it must be cleaned and dried thoroughly. Clean all surfaces before use. Failure to clean surfaces before using the unit could cause food contamination.**

Always unplug the unit after every use and before cleaning. Unplug the unit when not in operation.

Start by removing any excess kernels and debris by wiping toward the crumb tray openings. After the inside has been wiped clean, remove the crumb tray and discard any debris. *It is recommended to clean the crumb tray prior to reinserting it into the unit.*

The interior popcorn maker should be cleaned after each use with a cloth and warm, soapy water. The exterior of the unit may be cleaned by carefully wiping with a damp cloth.

**Warning: The cooking surface of the kettle and the bottom floor of the unit will be hot after use. Exercise caution when handling cooking utensils and cookware.**

The kettle is removable from this unit, but it is not intended to be washed in the dishwasher or immersed in water. Please allow kettle to cool before attempting to clean. After completely cooled, remove the kettle from unit by disconnecting the plug, then unhinging from its support. Use a cloth with warm, soapy water to clean.

Do not immerse the device completely in water for any reason. DO NOT use a pressure washer to clean.

After cleaning, ensure that the kettle is plugged in correctly when reinstalling for proper operation.

**NOTE: Proper cleaning instructions must be followed; otherwise, operation of the unit may be seriously impaired. Do not wash parts in an automatic dishwasher.**

WINCO® authorized service personnel must perform any other servicing.

## Safety

### SAFETY PRECAUTIONS

**Before installing and operating this equipment be sure everyone involved in its operation are fully trained and aware of all precautions. Accidents and problems can result from a failure to follow fundamental rules and precautions.**

- A WINCO® Approved Recommended Qualified Service Technician should carry out repairs if necessary. Do not remove any components or service panels on this product.
- Allow the unit to cool down after use before dismantling for cleaning; **the unit will be too hot to handle immediately after use.**
- Before cleaning, switch power OFF and disconnect power cord from the outlet.
- **Do not immerse unit in water or use hose to clean.**

**Ne jamais immerger l'appareil dans l'eau ni utiliser un jet d'eau pour le nettoyer.**

- If the power cord is damaged, it must be replaced by a WINCO® Approved Recommended Qualified Service Technician in order to avoid a hazard.

## Fuse Replacement:

1. Make sure the unit is off, unplugged, and cooled down.
2. Open doors and remove metal drop door.
3. Remove the screws metal tray.

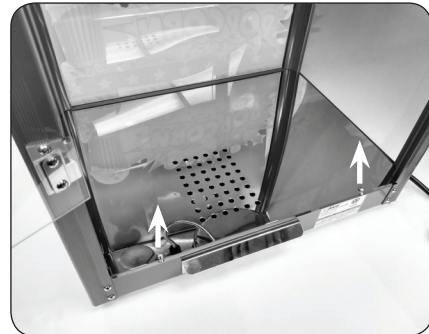

4. Remove screw and fuse box cover.



5. Untwist the ties holding the fuse holder and slide fuse holder up.

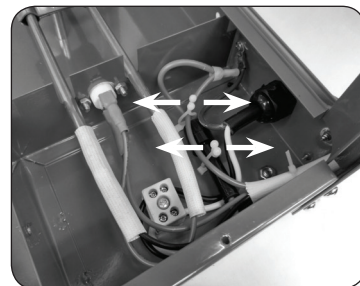

6. Open fuse holder. Remove old fuse and place in new fuse. Note: Use 15 amp buss fuse



7. Reassemble the unit.

## Assembly Instructions - Popcorn Cart (optional)

**MODEL: POP-8RC**

### CONTENTS

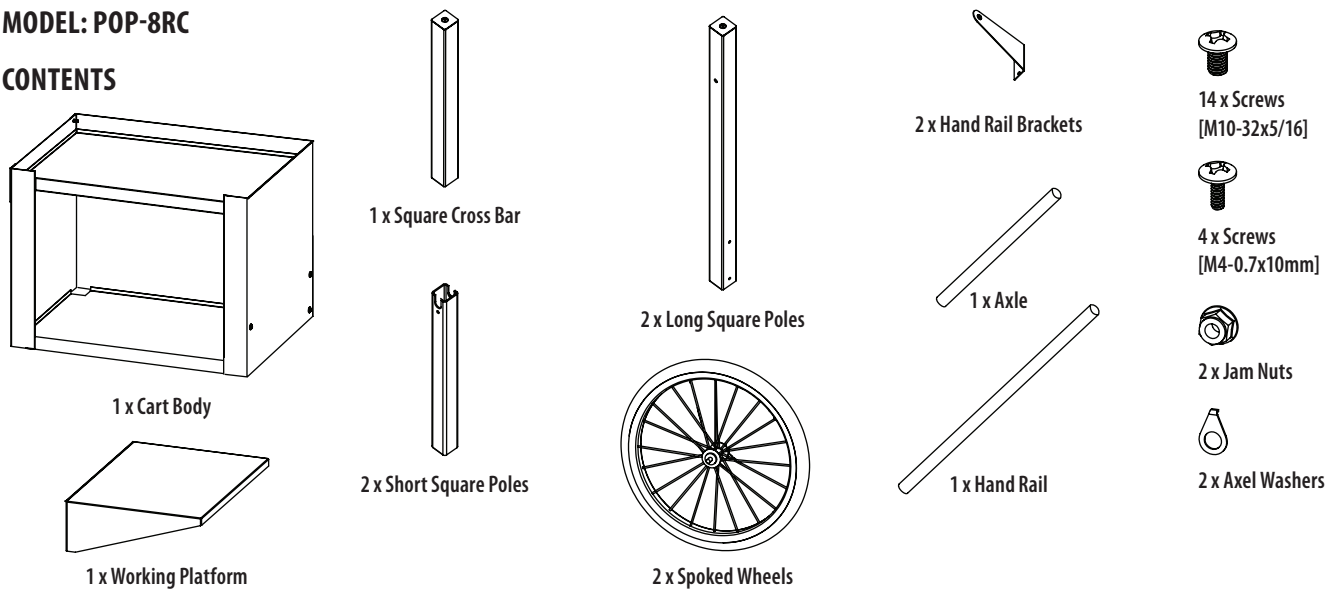

1. Attach cross bar to the long square poles with the longer screws.
2. Attach long and short square poles to the cart body with the shorter screws.
3. Slide the axle shaft onto the short square poles.
4. Attach the wheels on each side of the axle.  
Note: Check tire pressure before installing.  
Tire pressure should be 350kpa/ 50psi.
5. Attach the working platform to the cart body (on the same side as the wheels) and secure with the shorter screws.
6. Attach the hand rail to the hand rail brackets with longer screws.
7. Attach the assembled hand rail to the cart body with the shorter screws.
8. With the cart assembled, the cart can now be stood up right. Make sure everything is secure and leveled.

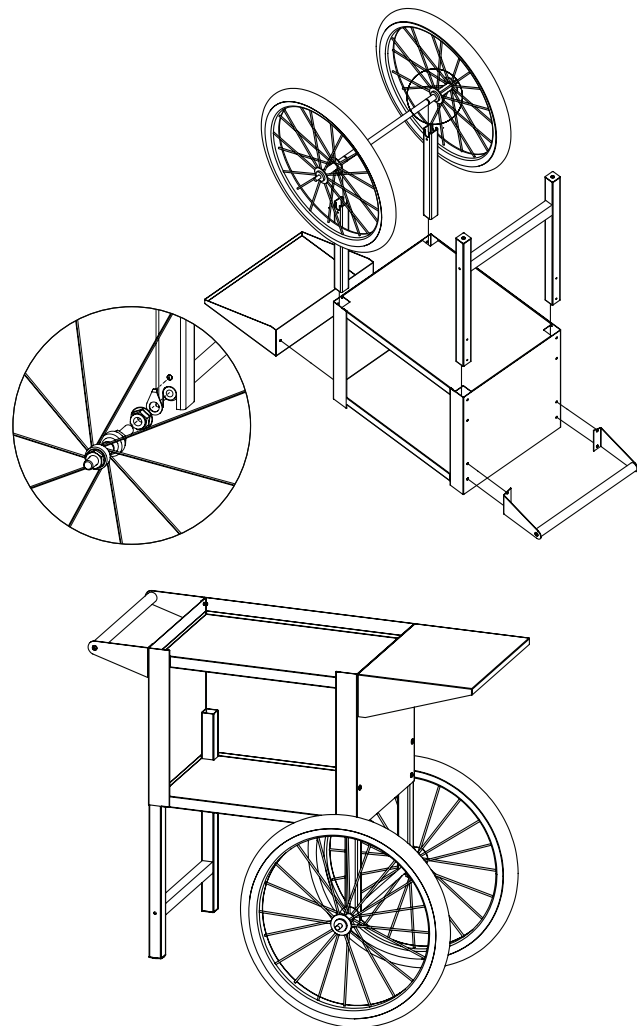

## Exploded View

MODEL SHOWN: POP-8R

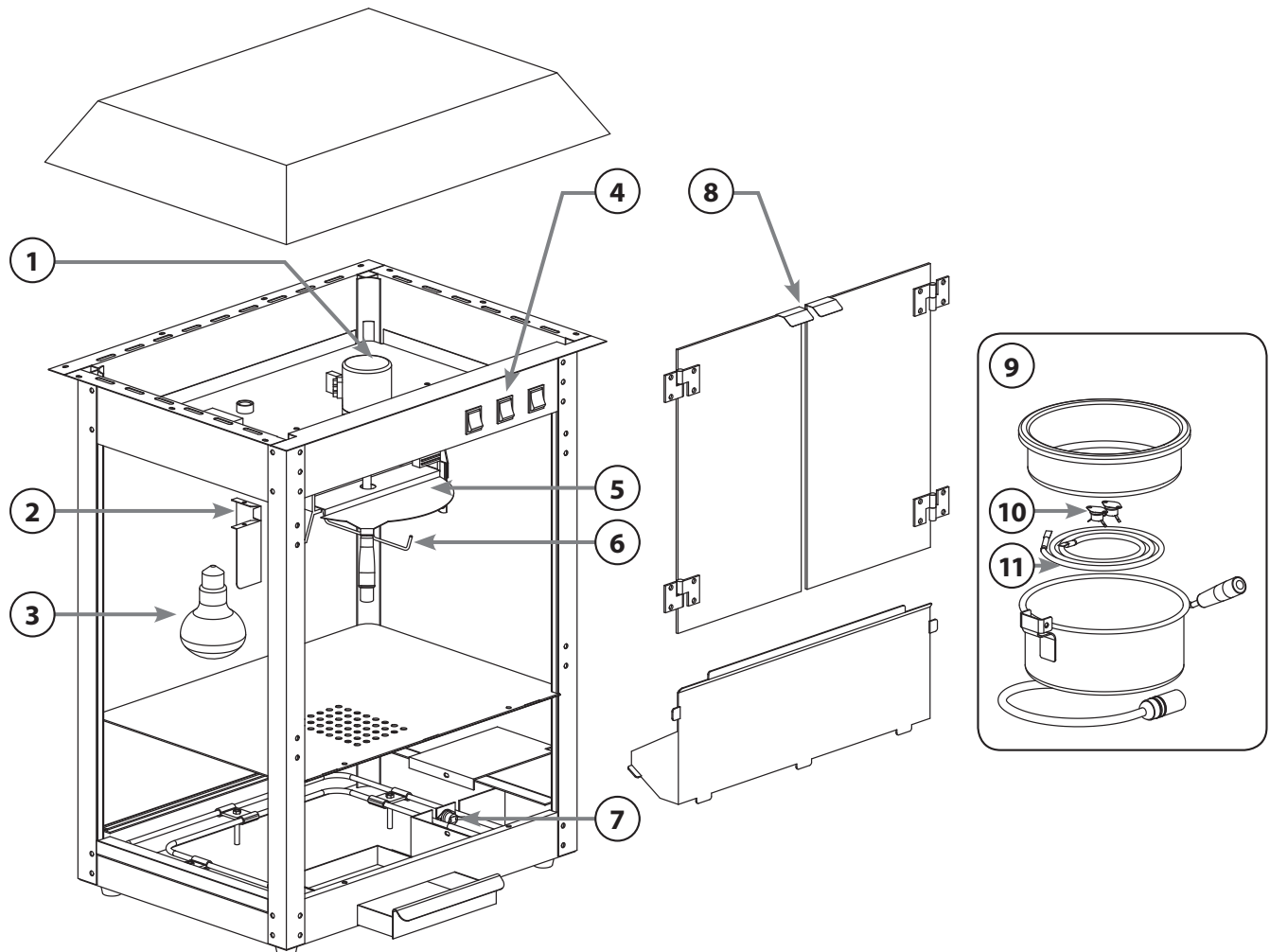

POP8-P2  
Kettle for POP-8B  
(includes stirrer assembly and kettle lid)



POP8-P1  
Kettle for POP-8R

## Parts List

MODELS: POP-8B / POP-8R

#	Description	POP-8B	POP-8R
1	Motor	POP8-P16	POP8-P6
2	Bulb Cover	POP8-P8	POP8-P8
3	Bulb	POP8-P7	POP8-P7
4	Switch	POP8-P4	POP8-P4
5	Kettle Lid	n/a	POP8-P13
6	Stirrer Assembly	n/a	POP8-P14
7	High Limit	POP8-P3	POP8-P3
8	Door Set	POP8-P12	POP8-P11
9	Kettle	POP8-P2	POP8-P1
10	Kettle Heater High Limit	POP8-P18	POP8-P17
11	Kettle Heater	n/a	POP8-P5
12	Gear	POP8-P9	n/a

*Please contact factory for special order parts not listed.*

## Electrical Circuit Diagram

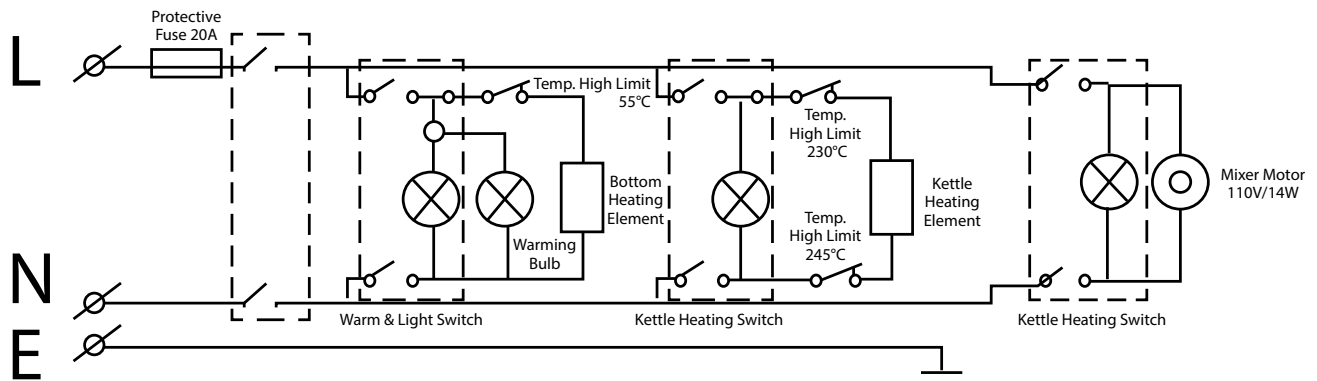

This circuit diagram has been provided to assist qualified electricians; only WINCO service agents or qualified electricians should carry out repairs if required.

Do not remove any components or service panels on this product.

## Troubleshooting

If your WINCO® Equipment does not operate properly, please check for the following problems/solutions prior to placing a service call.

PROBLEM	POSSIBLE CAUSE	RECOMMENDED SOLUTION
The unit is not turning on	Power supply	Check power supply cord is correctly plugged in and outlet is working
	Power switch is off	Check that the unit is plugged in and turned on
	Blown fuse	Change the fuse located under holding tray (see page 5)
	Plug/cord or external wiring damage	Remove and replace - <i>Replacement must be done by an authorized service provider.</i>
	Internal wiring fault	
The switch light is on, mixer is running, but kettle is not heating up	Kettle may not be plugged in internally	Check that the flexible conduit from the kettle is plugged into the receptacle on ceiling of internal cabinet
	Internal wiring fault	Check connections going from the power switch to the kettle outlet - <i>Replacement must be done by an authorized service provider.</i>
Kettle mixer not turning	Motor/power switch not on	Check the turn switch is in the "ON" position and light on the switch is on.
	Mixing shaft is locked or bent, causing the motor to stop spinning	Check that there is nothing obstructing the kettle mixer from rotating
	Internal wiring fault	Check connections between the motor and turn switch - <i>Replacement must be done by an authorized service provider.</i>
Internal light is not on	Light switch is in off position	Make sure the light switch is turned on
	Light bulb has burnt out	Replace bulb with same style light bulb
	Internal wiring fault	Call WINCO to make service arrangements through their service provider network

## Service and Repair

THIS EQUIPMENT MUST ONLY BE SERVICED BY AN AUTHORIZED AGENT.

### NOTE

Parts protected by the manufacturer or its agent are not to be adjusted by the installer unless the installer is an authorized service agent.

If you have any questions or problems DO NOT send unit to WINCO® without first contacting our customer service department.

See "Limited Warranty" section on page 11 for details.

## Limited Warranty

WINCO® warrants to the original purchaser of new equipment that said equipment, when installed in accordance with our instructions within North America and subjected to normal use, is free from defects in material or workmanship for a period of 1 year. The labor warranty is one year from original installation or 18 months from actual factory shipment date, whichever date occurs first.

**THIS WARRANTY IS IN LIEU OF ALL OTHER WARRANTIES, WHETHER EXPRESSED OR IMPLIED. WINCO EXPRESSLY DISCLAIMS ANY IMPLIED WARRANTY OF MERCHANTABILITY OR EXPRESSED OR IMPLIED WARRANTY OF FITNESS FOR A PARTICULAR PURPOSE.**

**WINCO'S OBLIGATION AND LIABILITY UNDER THIS WARRANTY IS EXPRESSLY LIMITED TO REPAIRING AND REPLACING EQUIPMENT THAT PROVES TO BE DEFECTIVE IN MATERIAL OR WORKMANSHIP WITHIN THE APPLICABLE WARRANTY PERIOD.**

**IN NO EVENT SHALL WINCO BE LIABLE FOR INCIDENTAL OR CONSEQUENTIAL DAMAGES TO BUYER OR ANY THIRD PARTY, INCLUDING, WITHOUT LIMITATION, LOSS OF PROPERTY, PERSONAL INJURY, LOSS OF BUSINESS OR PROFITS OR OTHER ECONOMIC LOSSES, OR STATUTORY OR EXEMPLARY DAMAGES, WHETHER IN NEGLIGENCE, WARRANTY, STRICT LIABILITY, OR OTHERWISE.**

This warranty is given only to the first purchaser from a retail dealer. No warranty is given to subsequent transferees.

Warranty does not cover product failures caused by: failure to maintain, neglect, abuse, damage due to excess water, fire, normal wear, improper set up and use. Periodic maintenance is not covered.

This warranty is not in force until such time as a properly completed and digitally signed Installation/Warranty Registration has been received by WINCO within 30 days from the date of installation.

### WARRANTY SERVICE

To initiate warranty service contact: [EquipService@winco.com](mailto:EquipService@winco.com) or call: 973-295-3996

DO NOT send unit to WINCO® without first contacting our customer service department.

### REGISTER ONLINE AT:

<http://support.winco.com>

Proof of purchase is required to extend warranty more than 1 year from date of shipment from the factory.

**THE FOREGOING WARRANTY PROVISIONS ARE A COMPLETE AND EXCLUSIVE STATEMENT BETWEEN THE BUYER AND SELLER. WINCO® NEITHER ASSUMES NOR AUTHORIZES ANY PERSONS TO ASSUME FOR IT ANY OTHER OBLIGATION OR LIABILITY IN CONNECTION WITH SAID EQUIPMENT.**

Examples of items not covered under warranty, but not limited to just these items:

1. Natural disasters (ie: earthquakes, tornadoes, hurricanes, etc.), fire, water damage, burglary, accident, theft.
2. Freight damage.
3. Improper installation or alteration of equipment.
4. Use of generic or after-market parts.
5. Repairs made by anyone other than a WINCO® designated service provider.
6. Lubrication.
7. Expendable wear parts, adjustable feet, blown fuses, lamps, etc.
8. Cleaning of equipment.
9. Misuse or abuse.

***Please keep this manual in a safe place for future use!***



Models: POP-8B / POP-8R

[www.wincous.com](http://www.wincous.com)