

Operating and installation instructions Built-in coffee machine



To avoid the risk of accidents or damage to the appliance it is **essential** to read these instructions before it is installed and used for the first time.

Caring for the environment

Disposal of the packing material

The packaging is designed to protect the appliance from damage during transportation. The packaging materials used are selected from materials which are environmentally friendly for disposal and should be recycled.

Recycling the packaging reduces the use of raw materials in the manufacturing process and also reduces the amount of waste in landfill sites.

Disposing of your old appliance

Electrical and electronic appliances often contain valuable materials. They also contain specific materials, compounds and components, which were essential for their correct function and safety. These could be hazardous to human health and to the environment if disposed of with your domestic waste or if handled incorrectly. Please do not, therefore, dispose of your old appliance with your household waste.



Please dispose of it at your local community waste collection / recycling centre for electrical and electronic appliances, or contact your dealer or Miele for advice. You are also responsible for deleting any personal data that may be stored on the appliance being disposed of. Please ensure that your old appliance poses no risk to children while being stored prior to disposal.

Caring for the environment	2
Warning and Safety instructions	6
Guide to the machine	15
Controls and indicators	17
Operation	19
Symbols in the display	21
Miele@home	22
Before using for the first time	23
Before using for the first time	23
Switching on for the first time	23
Filling the coffee bean container	25
Filling the water container	26
Switching on and off	27
Spout adjustment	28
Making drinks	29
Making coffee with and without milk.....	29
Milk preparation.....	30
Making a coffee.....	31
Cancelling a drink.....	31
DoubleShot.....	31
Making 2 portions (☑ sensor control).....	32
Coffee pot.....	32
Tea.....	33
TeaTimer.....	34
Making tea.....	34
Teapot.....	35
Dispensing warm or hot water	35
Expert mode	36
Grinder setting	37
Parameters	38
Displaying and changing parameters.....	38
Portion size.....	38
Quantity of coffee.....	39

Contents

Brewing temperature	39
Pre-brewing the ground coffee.....	39
Profiles	40
Creating a profile	40
Changing drinks within a profile	40
Making drinks stored in a profile	40
Editing profiles.....	40
Setting when the profile should change	40
Changing the name	41
Deleting a profile	41
MobileStart	42
Settings	43
Displaying and changing Settings.....	43
Language.....	43
Time.....	43
Date	43
Timer	43
Switch on at	43
Switch off at	44
Switch off after	44
TeaTimer.....	44
Volume.....	44
Display brightness.....	44
Lighting.....	44
Info (display information)	44
Fresh water.....	44
Altitude	44
Performance mode.....	45
Eco mode	45
Barista mode	45
Latte mode	45
Party mode	45
Water hardness	45
System lock 	46
Miele@home	47
Remote control.....	47
RemoteUpdate	47
Software version.....	48
Showroom programme (Demo mode).....	48
Factory defaults.....	48

Cleaning and care	49
Overview of cleaning intervals.....	49
Cleaning by hand or in the dishwasher	50
Unsuitable cleaning agents	51
Cleaning the drip tray and waste container.....	52
Cleaning the drip tray cover	54
Water container	54
Cleaning the central spout	54
Cleaning the cup rim sensor	56
Cleaning the milk flask with lid.....	57
Cleaning the milk valve (daily)	57
Removing and cleaning the milk valve (once a month).....	58
Cleaning the bean containers.....	61
Removing the brew unit and cleaning it by hand.....	62
Cleaning the interior, inside of the machine door and drip tray	63
Cleaning the front of the machine	64
Maintenance programmes.....	65
Rinse the appliance.....	65
Rinse the milk pipework	65
Degreasing the brew unit and cleaning the interior.....	66
Descaling the machine	69
Problem solving guide	71
Messages in the display	71
Unusual performance of the coffee machine	74
Unsatisfactory results.....	77
After sales service and warranty	79
Contact in the event of a fault	79
Warranty	79
Accessories	80
Installation	81
Mains water connection	81
Electrical connection	83
Building-in dimensions	84
Building in the coffee machine.....	86
Door opening limiters	87
Technical data	88
EU Conformity declaration	89
UK Conformity declaration	90

Warning and Safety instructions

This coffee machine complies with all the stipulated safety requirements. Inappropriate use can, however, lead to personal injury and material damage.

Read the operating instructions carefully before using the coffee machine. They contain important information on safety, installation, use and maintenance. This prevents both personal injury and damage to the coffee machine.

In accordance with standard IEC 60335-1, Miele expressly and strongly advises you to read and follow the instructions in the chapter on installing the coffee machine as well as the safety instructions and warnings.

Miele cannot be held liable for injury or damage caused by non-compliance with these instructions.

Keep these operating instructions in a safe place and pass them on to any future owner.

Correct application

- ▶ This coffee machine is intended for home use.
- ▶ This coffee machine is not intended for outdoor use.
- ▶ This coffee machine must not be used at altitudes above 2000 m.
- ▶ It must only be used as a domestic appliance to make espresso, cappuccino, latte macchiato, tea etc. Any other use is not permitted.
- ▶ This coffee machine can only be used by people with reduced physical, sensory or mental capabilities, or lack of experience and knowledge, if they are supervised whilst using it, or have been shown how to use it in a safe way and recognise and understand the consequences of incorrect operation.

Warning and Safety instructions

Safety with children



Danger of burning and scalding on the dispensing spouts.

Children's skin is far more sensitive to high temperatures than that of adults.

Ensure children do not touch hot surfaces of the coffee machine or place parts of their body under the dispensing spouts.

- ▶ Install the coffee machine where it is out of the reach of children.
- ▶ Children under 8 years of age must be kept away from the coffee machine unless they are constantly supervised.
- ▶ Children aged 8 and older may only use the coffee machine without supervision if they have been shown how to use it in a safe manner.
Children aged 8 and older must be aware of the potential dangers caused by incorrect operation.
- ▶ Please supervise children in the vicinity of the coffee machine and do not allow them to play with it.
- ▶ Young children must not be allowed to clean the coffee machine at all. Cleaning may only be carried out by children 8 years of age or older under the supervision of an adult.
- ▶ Remember that coffee and espresso are not suitable drinks for children.
- ▶ Danger of suffocation! Whilst playing, children may become entangled in packaging material (such as plastic wrapping) or pull the packaging material over their head, presenting the risk of suffocation. Keep packaging material away from children.

Technical safety

- ▶ Installation work or repairs should only be carried out by a Miele authorised technician. Unauthorised or incorrect installation work or repairs can pose considerable danger to users.
- ▶ A damaged coffee machine could be dangerous. Before building in the machine, check it for any externally visible damage. Do not use a damaged machine.
- ▶ To avoid the risk of damage to the machine, make sure the connection data (voltage and frequency) on the data plate corresponds to the household supply, before connecting the machine to the mains supply. Consult a qualified electrician if in any doubt.
- ▶ The electrical safety of this coffee machine can only be guaranteed when correctly earthed. It is essential that this standard safety requirement is met. If in any doubt please have the electrical installation tested by a qualified electrician.
- ▶ Reliable and safe operation of the coffee machine can only be guaranteed if it is connected to the mains electrical supply.
- ▶ Do not connect the machine to the mains electricity supply by a multi-socket adapter or an extension lead. These are a fire hazard and do not guarantee the required safety of the appliance.
- ▶ The coffee machine must not be used in a non-stationary location (e.g. on a ship).
- ▶ For safety reasons, this machine may only be used when it has been built in.
- ▶ If the coffee machine is to be built in above another appliance, there must be a full-width, closed shelf between them (except when it is combined with a suitable built-in plate/food warming drawer).
- ▶ Only use the coffee machine in rooms where the ambient temperature is between +16 °C and +38 °C.

Warning and Safety instructions

- ▶ A minimum installation height of 850 mm must be observed.
- ▶ This coffee machine must not be installed behind a closed cabinet door because heat and moisture can build up behind it. This can result in damage to the machine and/or furniture unit.
- ▶ The coffee machine must be disconnected from the electricity supply during repair work.
- ▶ While the machine is under warranty, repairs should only be undertaken by a Miele authorised service technician. Otherwise the warranty is invalidated.
- ▶ Never open the outer casing of the machine. Tampering with electrical connections or components and mechanical parts is highly dangerous to the user and can cause operational faults or electric shock.

Mains water connection

- ▶ Do not connect the coffee machine to a hot water supply.
- ▶ The stopcock must be easily accessible after the coffee machine has been built in.
- ▶ The protective sleeve of the water inlet hose must not be damaged or become kinked.
- ▶ The integrated water protection system offers protection from water damage, provided the following conditions are met:
 - The coffee machine is correctly installed, connected to the electricity supply and plumbed in.
 - If a fault is identified, the coffee machine must be repaired immediately.
 - The stopcock is turned off when the machine is not in use for an extended period (e.g. during holidays).

Correct use

 Danger of burning and scalding on the dispensing spouts. The liquids and steam dispensed are very hot.

Keep well away from the area underneath the spouts when hot liquids and steam are being dispensed.

Do not touch hot components.

Hot liquid or steam could spatter from the nozzles. Ensure that the central spout is clean and fitted correctly.

Before opening the door, remove any containers from the drip tray in the machine door.

Water in the drip tray can also be very hot. Take care when emptying it.

 Danger of injury to the eyes.

Never look directly at the lighting or use optical instruments to look at it.

► Please note the following regarding water:

- The water quality must conform to the requirements for drinking water in the country in which the coffee machine is being used.
- If the water container is filled manually: only use cold, fresh tap water to fill the water container. Hot or warm water or other liquids can damage the coffee machine.
- Change the water every day to prevent a build-up of bacteria. If the machine is plumbed into the mains water supply: empty the water container once a day.
- Do not use carbonated water.

► Only put roasted coffee beans in the bean containers. Do not place coffee beans which have been treated with additives or ground coffee inside the bean containers.

► Do not fill the bean containers with any type of liquid.

Warning and Safety instructions

- ▶ Do not use green (unroasted) coffee beans or mixtures of coffee beans which contain green coffee beans. Green coffee beans are very hard and still contain residual moisture. These can damage the coffee machine grinder as soon as grinding begins.
- ▶ Do not use coffee beans which have been treated with caramel, sugar or other substances including sugary liquids. Sugar will damage the coffee machine.
- ▶ Only use milk without additives. Additives in milk usually contain sugar and this will stick to the milk pipework.
- ▶ If using dairy milk make sure that it has been pasteurised.
- ▶ When making tea, please follow the instructions on the packaging.
- ▶ Do not place flaming alcohol mixtures underneath the central spout. The flames could ignite plastic components and cause them to melt.
- ▶ Do not swing from or hang anything on the machine front when it is open as this could damage the hinges on the coffee machine.
- ▶ The machine must not be used for cleaning objects.

Accessories and spare parts

- ▶ Miele can only guarantee the safety of the machine when original Miele spare parts are used. Faulty components must only be replaced by genuine Miele original spare parts.
- ▶ Only use original Miele accessories. If other parts are used, warranty, performance and/or product liability claims will be invalidated.
- ▶ Miele will guarantee to supply functional spare parts for a minimum of 10 years and up to 15 years following the discontinuation of your coffee machine.

Cleaning and care

- ▶ Clean the coffee machine and the milk flask daily, particularly before using them for the first time.
- ▶ All parts of the milk system need to be cleaned thoroughly and regularly. Milk contains bacteria which proliferate rapidly with inadequate cleaning.
- ▶ Descale the coffee machine regularly depending on the water hardness level in your area. Descale the machine more frequently in areas with very hard water. Miele cannot be held liable for damage arising from insufficient descaling, the use of incorrect descaling agent or the use of descaling agent which is not of the appropriate concentration.
- ▶ Degrease the brew unit regularly with Miele cleaning tablets. Depending on the natural oil content of the coffee used, the brew unit can become blocked quite quickly.
- ▶ Do not use a steam cleaner to clean this machine. Steam could reach electrical components and cause a short circuit.
- ▶ Used coffee grounds should be disposed of with the organic rubbish or on the compost heap. Do not empty them down the sink, as they could block it.

Warning and Safety instructions

For machines with stainless steel surfaces:

- ▶ Do not use sticky notes, transparent adhesive tape, masking tape or other types of adhesive on the stainless steel surfaces. These will damage the stainless steel surfaces, causing them to lose their dirt-repellent protective coating.
- ▶ The finish on stainless steel surfaces is susceptible to scratching. Even magnets can cause scratching.

Exterior view

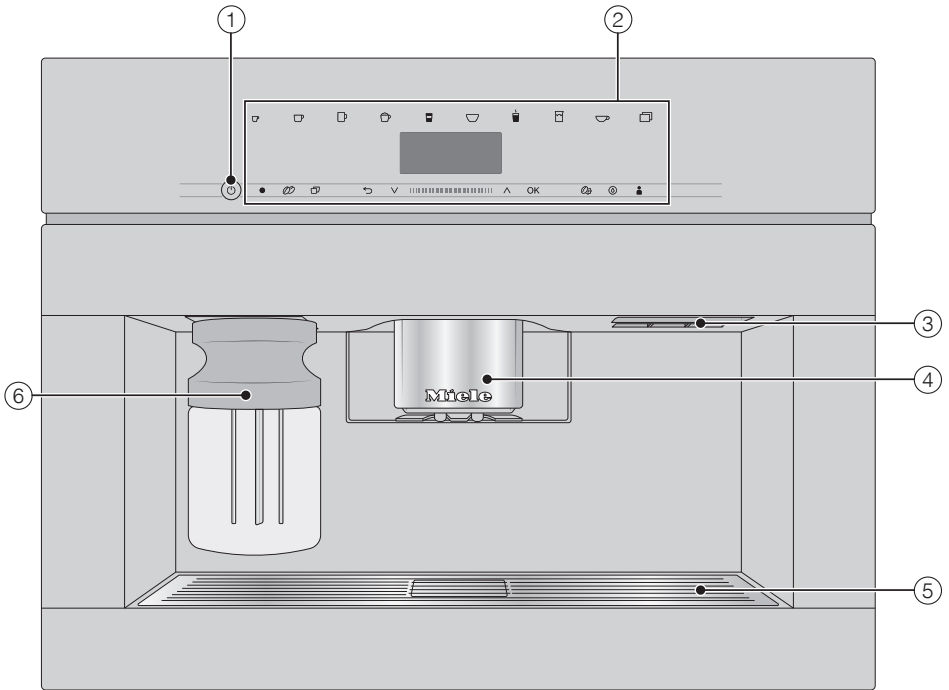

- ① On/Off button ①
- ② Control panel
- ③ Door handle
- ④ Height-adjustable central spout with lighting
- ⑤ Drip tray cover
- ⑥ Milk flask

Guide to the machine

Interior view

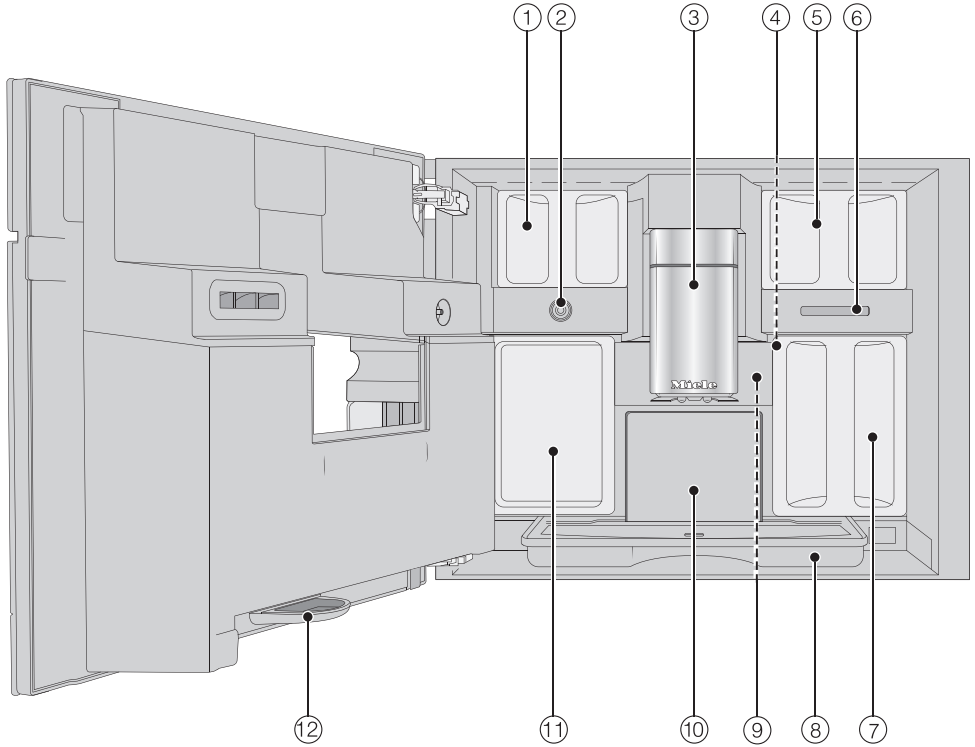



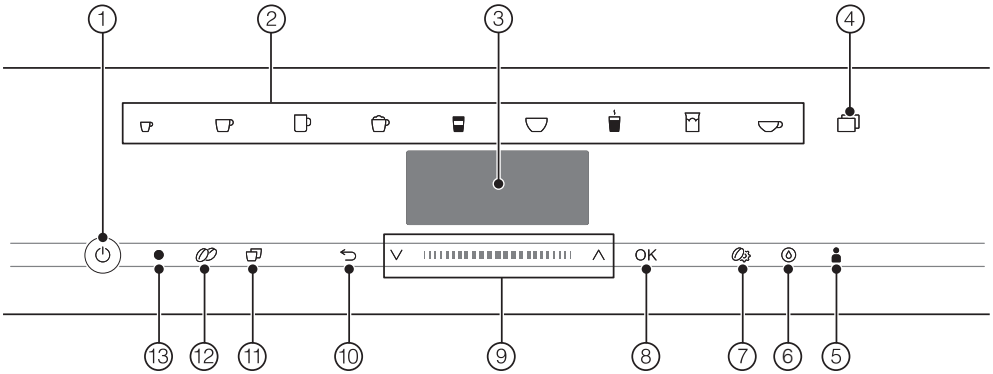





- ① Bean container
- ② Milk valve
- ③ Height-adjustable central spout with lighting
- ④ Grinder setting
- ⑤ Bean container
- ⑥ Fan outlet
- ⑦ Water container
- ⑧ Drip tray with lid
- ⑨ Brew unit
- ⑩ Waste container
- ⑪ Maintenance container
- ⑫ Drip tray



- ① **On/Off button** ①
For switching coffee machine on and off
- ② **Drink buttons**
For making drinks
- ③ **Display**
For showing information about the current action or status
- ④ **☑ sensor**
 - For making other drinks, e.g. Ristretto, Cappuccino italiano
 - For making a pot of tea or coffee
 - Menu: Settings 🚩
- ⑤ Profiles 👤 **sensor**
For creating and managing profiles
- ⑥ Maintenance ⌚ **sensor**
Maintenance programmes, e.g. Descale
- ⑦ Parameters ⚙️ **sensor**
For displaying or changing drink settings
- ⑧ **OK sensor**
For confirming display messages and saving settings
- ⑨ **Navigation area with arrow buttons** ^ v
For scrolling through lists, selecting entries or changing values
- ⑩ **“Back”** ⬅️ **sensor**
For returning to the previous menu and cancelling unwanted actions
- ⑪ **“2 portions”** ☑ **sensor**
For dispensing 2 portions of a drink at once
- ⑫ **“DoubleShot”** ☕ **sensor**
For making a particularly strong and aromatic coffee by using twice as much ground coffee but the same amount of water
- ⑬ **Optical interface**
(For Miele Customer Service Department only)

Controls and indicators

Drink button symbols

-  Espresso
-  Coffee
-  Long coffee
-  Cappuccino
-  Latte macchiato
-  Caffè latte
-  Hot milk
-  Milk froth
-  Tea water

Sensors

To operate the coffee machine, touch the sensors with your finger.

An audible signal is generated each time a sensor is touched. You can adjust the volume of the signal tones or switch the tones off (see “Settings – Volume”).

Drinks menu

When the following appears in the display, you are in the drinks menu: Select drink.

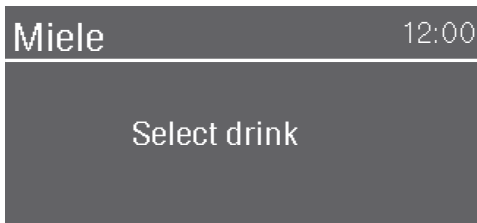

You can find more drinks in the Further menu (☐ sensor control).

Navigation area

To select a menu option, keep pressing the arrow buttons ^ and v until the option you want is highlighted.

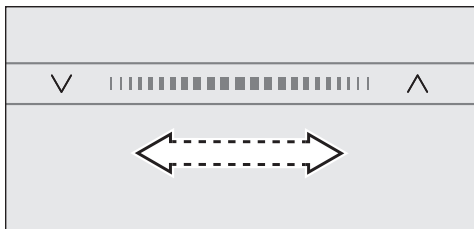

To scroll more quickly through the options, swipe your finger right or left in the area between the arrows.

As soon as you reach a confirmable value, message or setting, the OK sensor will light up orange.

Touch OK to confirm your selection.

Selecting a menu and navigating within a menu

To select a menu, touch the relevant sensor, e.g. the ☐ sensor.



You will then be able to start an action or change settings in the menu. A bar on the right-hand side of the display indicates that further options or text are available.

The setting which is currently selected in a list will have a tick ✓ beside it.

Exiting a menu or cancelling an action

To exit the current menu, touch the ↩ sensor.

Alternatively, touch the lit orange sensor again to return to the drinks menu.

Entering a name

Letters and numbers are entered via the navigation area. You can choose between upper and lower case letters.

Tip: It is best to select short names.



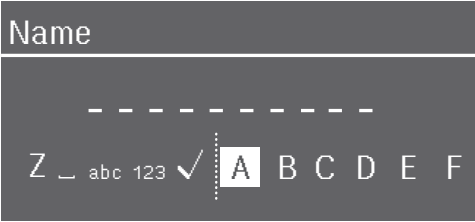





Operation



- To enter a character, highlight the one you want and confirm your choice with *OK*.
- To delete a character, touch the ↶ sensor control.
- To save the name, select the tick ✓ and confirm with *OK*.

Symbols in the display

The following symbols may also appear in the display in addition to the text:

Symbol	Explanation
	This symbol indicates the “Settings” menu and the “Language” menu option.
	This symbol indicates that there is additional information and advice about using the coffee machine. Select OK to confirm the information.
	This symbol appears if the system lock is activated. Operation is locked.
	The symbol and the desired switching-on time appear in the display 23:59 hours before the coffee machine is due to switch on if the Switch on at timer and setting for displaying the time are activated (see “Settings – Timer”).
	The TeaTimer minute minder has been started (see “Tea – TeaTimer”). The remaining brewing time is shown next to the symbol.
	This symbol appears while the appliance is being descaled. (This symbol can also be found on the water container: fill up to this mark).
	This symbol appears during the Clean the milk pipework maintenance programme. (This symbol is also found on the water container: fill up to this mark with water).
	If Miele@home has been activated for the coffee machine, these symbols represent the quality/status of the WiFi connection, indicating the strength in increments from strong to not connected.

Miele@home

Your coffee machine is equipped with an integrated WiFi module.

To use this feature, you will need:

- A WiFi network
- The Miele app
- A Miele user account. You can create a user account via the Miele app.

The Miele app will guide you through the process of connecting your coffee machine to your home WiFi network.

Once your coffee machine is connected to your WiFi network, you can use the app to carry out activities such as the following:

- Calling up information on the operating status of your coffee machine
- Changing settings on your coffee machine
- Controlling your coffee machine remotely

Connecting your coffee machine to your WiFi network will increase energy consumption, even when the machine is switched off.

Before installing the coffee machine in its final location, ensure that the signal from your WiFi network is strong enough.

Availability of the WiFi connection

The WiFi connection shares a frequency range with other appliances (including microwave ovens and remote control toys). This can give rise to sporadic or

even complete connection failures. Therefore, the availability of featured functions cannot be guaranteed.

Miele@home availability

The ability to use the Miele app depends on the availability of the Miele@home service in your country.

The Miele@home service is not available in every country.

For information about availability, please visit www.miele.com.

Miele App

The Miele App is available to download free of charge from the Apple App Store® or from the Google Play Store™.



Before using for the first time

Before using for the first time

- Connect the coffee machine to the water and electricity supplies.
- Install the coffee machine by building it in.
- Remove any notices from the machine.
- Remove the protective foil from the drip tray cover.
- Clean the water container, the bean containers and the central spout.
- Remove the bean containers and fill them with roasted coffee beans.

Switching on for the first time

- Touch the On/Off button (⏻).

Selecting the display language

- Select the desired display language.

You might also be asked for your location.

The choice of location determines how the time of day is displayed, e.g. in the 12 or 24-hour format, as well as how units are displayed and so on.

Setting up the network (Miele@home)

You can connect your coffee machine to your home WiFi network.

The following appears in the display during set-up: Set up "Miele@home"

Tip: You can also choose to set up Miele@home for your coffee machine at a later point. In this case, select Skip.

- Make sure that your WiFi network signal is sufficiently strong in the place where you want to set up your coffee machine.
- Touch Continue.
- Select the connection method you wish to use.
- Follow the instructions provided in the coffee machine display and in the Miele app.

Connection successfully established. will appear in the display.

- Touch Continue to proceed with the set-up.

Setting the date

- Set the current date and touch OK.

Setting the time of day

- Set the current time of day and touch OK.

If the coffee machine has been connected to a WiFi network and is signed into the Miele app, the time will be synchronised based on the location setting in the Miele app.

Setting the water hardness level

Contact your local water supplier to find out your local water hardness range if necessary.

More information can be found under "Settings – Water hardness".

- Enter your local water hardness (in °dH) and confirm with OK.

Before using for the first time

Selecting the water supply (Mains water)

The coffee machine is intended to be plumbed into the mains water supply. You can select one of the following options:

- **On:** The water container will be filled automatically via the mains water connection.
 - **Off:** You must fill the water container manually. A message appears in the display to inform you of this.
- Select the water supply and confirm with *OK*.

The setting is now saved.

Selecting the Performance mode

You can select the appropriate mode to suit your personal preferences (see “Settings – Performance mode”).

- **Eco mode:** This is an energy-saving mode.
 - **Barista mode:** This mode has been optimised for unadulterated coffee enjoyment.
 - **Latte mode:** In this mode, milk-based drinks can be prepared within a much shorter space of time.
- Select the desired mode and confirm with *OK*.

Your machine has been successfully set up and is ready for use.

To ensure that any coffee residues from the factory testing process are removed from the brewing system, please throw away the first 2 cups of coffee when using the coffee machine for the first time.

Filling the coffee bean container

Coffee or espresso can be made from whole roasted coffee beans which are freshly ground for each portion. This requires the bean containers to be filled with coffee beans.

 Risk of damage to the grinder due to incorrect operation.

The coffee machine will be damaged if the bean container is filled with unsuitable substances such as liquids, ground coffee or coffee beans treated with sugar, caramel or similar.

In addition, green (unroasted) coffee beans or mixtures of coffee beans which contain green coffee beans can damage the grinder. Green coffee beans are very hard and still contain residual moisture. These can damage the coffee machine grinder as soon as grinding begins.

Only put roasted coffee beans in the bean containers.

The coffee machine has 2 bean container drawers on the top left and right. Coffee beans from all 3 bean containers are mixed together during grinding.



- Open the appliance door.

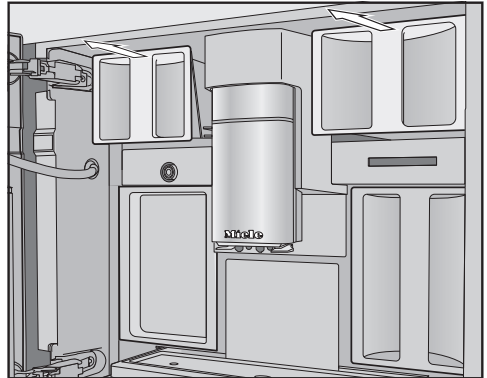

- Pull out the bean containers.
- Take the lids off the bean containers and fill them with coffee beans.
- Put the lids back on the bean containers to seal them.
- Slide the bean container drawers all the way into the coffee machine. Close the appliance door.

Filling the water container

⚠ Risk to health due to contaminated water.

Bacteria can develop in water which has been sitting in the water container for too long and is a risk to your health. Water that gets left in the inlet hose can also impair the flavour if you do not make any drinks for a long time.

Change the water in the water container **every day**.

Discard the first full container of water if you have not made any drinks for a while.

If the coffee machine is plumbed into the mains drinking water supply, the water container will fill automatically as soon as the coffee machine is switched on.

You can fill the water container manually at any time.

⚠ Risk of damage due to incorrect operation.

Unsuitable liquids such as hot or warm water or other liquids can damage the coffee machine. Carbonated water leaves too much limescale in the coffee machine.

If filling the water container manually: Only use fresh, cold tap water.



- Open the appliance door.

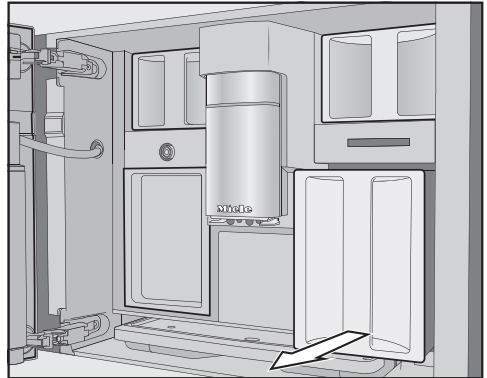

- Pull the water container forwards to remove it.
- Fill the water container with fresh, cold drinking water up to the *max.* mark.
- Push the water container into the machine and close the door.

Switching the coffee machine on

- Touch the On/Off button ①.

The coffee machine heats up and rinses the pipework. Hot water will run out of the central spout.

You can now make drinks.

If the coffee machine is already at operating temperature, rinsing will not take place.

Switching the coffee machine off

- Touch the On/Off button ①.

If coffee has been dispensed, the coffee machine will rinse the coffee pipework automatically before switching off.

While dispensing a drink or during maintenance processes, moisture builds up in the coffee machine. Once a drink has been dispensed or the appliance has been switched off, the internal fan will continue to run until the interior is sufficiently dehumidified. You will hear an accompanying noise.

Switching off for longer periods of time

If the coffee machine is not going to be used for a while, e.g. if you are going on holiday, remember to do the following:

- Empty the drip tray, the waste container and the water container.
- Clean all parts thoroughly, including the brew unit and interior of the machine.
- Switch the coffee machine off.

Spout adjustment

The central spout **cannot** be manually adjusted.

Before making the drink, the central spout moves down and the cup sensor stops it at the optimum height for the cups or glasses being used.

When the coffee machine is switched off, the central spout will be in the middle position.

When a maintenance programme is being carried out, the central spout will move to the height of the maintenance container or into a low maintenance position.

Make sure that the central spout is in the top or middle position before you open the door.

 Danger of burning and scalding on the dispensing spouts.

The liquids and steam dispensed are very hot and can cause scalding.

Keep well away from the area underneath the spouts when hot liquids and steam are being dispensed.

Do not touch hot components.

Making coffee with and without milk

The following drinks can be made:

- **Ristretto** is a strong, concentrated espresso. It is prepared with the same amount of coffee as for an espresso but with a lot less water.
- **Espresso** is a strong aromatic coffee with a thick hazelnut brown coloured froth – known as the crema – on top. We recommend using espresso-roasted coffee beans to make an espresso.
- **Coffee** differs from espresso by the increased amount of water and the roast of the beans. We recommend using coffee beans of the correct roast to make the coffee.
- **Long coffee** is a coffee with considerably more water.
- **Long black.** This is made with hot water and two shots of espresso.
- **Caffè Americano** consists of espresso and hot water. The espresso is made first, then the hot water is dispensed into the cup.

- **Cappuccino** consists of approx. 2 thirds milk froth and 1 third espresso.
- **Latte macchiato** consists of 1 third each of hot milk, milk froth and espresso.
- **Caffè latte** consists of espresso and hot milk.
- **Cappuccino italiano** has the same proportions of milk froth and espresso as a cappuccino. The difference is that the espresso is added first and then the milk froth.
- **Espresso macchiato** is an espresso with a small amount of milk froth on top.
- **Flat white** is a special variety of cappuccino that contains significantly more espresso than milk froth for an intensive coffee aroma.
- **Café au lait** is a French style of coffee consisting of coffee and milk froth. Café au lait is usually served in a bowl.

Hot milk or milk froth can also be made.

Making drinks

Milk preparation

Milk or milk alternatives (e.g. soya milk) containing added sugar can clog up the milk pipe and the rest of the milk pipework. Residues from unsuitable liquids can interfere with milk preparation.

The milk used must not contain any additives.

Only use pasteurised cow's milk.

Tip: Using cold cow's milk ($< 10\text{ }^{\circ}\text{C}$) with a protein content of at least 3 % will produce the perfect milk froth. You can select milk with a fat content according to preference. With whole milk (at least 3.5 % fat), the milk froth will be slightly creamier than with low-fat milk.

The milk flask

Milk is **not** cooled in the milk flask. For high-quality milk froth, always use cold milk ($< 10\text{ }^{\circ}\text{C}$).

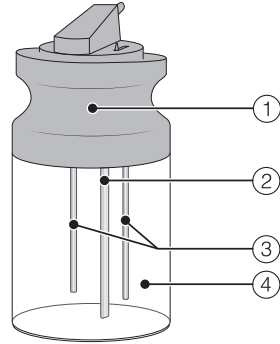

- ① Lid
- ② Milk suction tube
- ③ Sensor
- ④ Glass flask

Filling and inserting the milk flask

- Fill the milk flask with milk up to a maximum of 2 cm below the rim. Seal the milk flask with the lid.

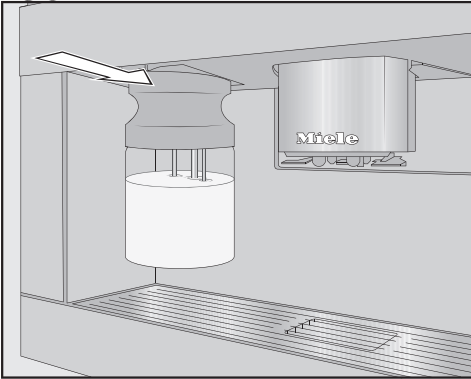

- Push the milk flask back into the coffee machine until it clicks into place.

Tip: It is easier to remove the milk flask with both hands.

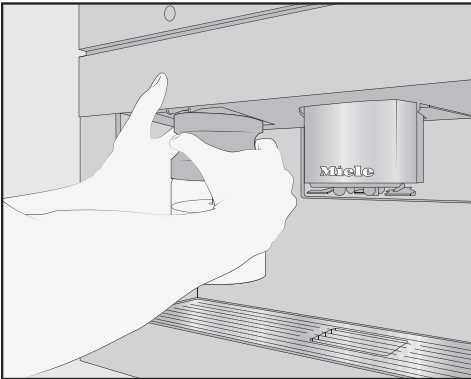

Making a coffee

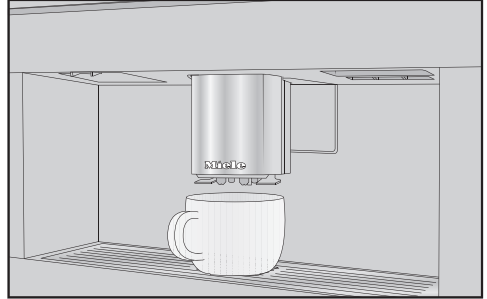

- Place a cup under the central spout.
- Touch the sensor for the drink you want.

The drink will be dispensed from the central spout into the cup.

Cancelling a drink

- Touch the lit orange symbol on the control panel again.

When preparing drinks with several ingredients (e.g. latte macchiato) you can cancel each of the individual components prematurely.

- Touch OK when Stop appears in the display.

DoubleShot

Select the DoubleShot  function if you would like a particularly strong and aromatic coffee. In this case, more coffee beans will be ground and brewed halfway through the brewing process. The shorter extraction time means that fewer unwanted aromas and bitter compounds will be released.

DoubleShot can be activated for all drinks apart from “Ristretto” and “Long black”.

Making drinks

Making a DoubleShot ☉ of coffee

- Press the ☉ sensor control immediately before or after you start making a drink.

Dispensing starts and the ☉ sensor control lights up. 2 portions of coffee beans will be ground and brewed.

Making 2 portions (☐ sensor control)

You can dispense 2 portions of a drink into 1 large cup or into 2 cups at the same time.

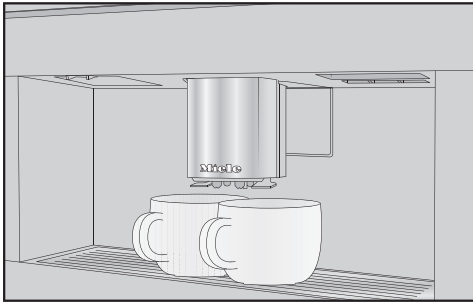

- Place a cup under each of the coffee dispensers in the central spout.
- Press the ☐ sensor control immediately before or after you start making a drink.

The ☐ sensor control lights up.

The dispensing starts and 2 portions of the desired drink will be dispensed.

Coffee pot

You can make several cups of coffee one after the other automatically with the Coffee pot function (maximum of 1 litre).

The drinks menu is displayed.

Tip: Make sure that the bean and water containers have enough beans and water inside them before starting the Coffee pot function.

- Place a sufficiently large container under the central spout.
- Touch the ☐ sensor control.
- Select Coffee pot and confirm with OK.
- Select the number of cups you want (3 to 8).

Each portion of coffee will be brewed and dispensed individually. You can follow the process in the display.

Cancelling a drink

- Touch the ☐ sensor control.

Tea

The coffee machine is not intended for commercial or scientific purposes. Temperatures given are approximate and can vary according to ambient conditions.

To make tea, you can select from the following options:

- **Japanese tea** is a high-quality green tea which boasts a fine, fresh, “green” taste.
Dispensed temperature:
approx. 65 °C, brewing time:
approx. 1.5 minutes
- **White tea** is a green tea where only the young buds of the tea plant are used and processed very gently. White tea has a particularly mild taste.
Dispensed temperature:
approx. 70 °C, brewing time:
approx. 2 minutes
- **Green tea** gets its green colour from the leaves of the tea plant. The tea leaves are either roasted or steamed depending on the region. Green tea can be infused multiple times.
Dispensed temperature:
approx. 80 °C, brewing time:
approx. 2.5 minutes
- **Black tea** gets its dark colour and characteristic taste from the fermentation of tea leaves. Black tea can be enjoyed with a little lemon or milk.
Dispensed temperature:
approx. 97 °C, brewing time:
approx. 3 minutes

- **Chai latte** has its origins in traditional Ayurveda medicine as a black tea with typically Indian spices and milk. The milk mellows the spices and tops off the flavour experience.
Dispensed temperature:
approx. 97 °C, brewing time:
approx. 3 minutes
- **Herbal tea** is an aromatic infusion drink made up of dried leaves or fresh parts of plants.
Dispensed temperature:
approx. 97 °C, brewing time:
approx. 8 minutes
- **Fruit tea** is made from dried pieces of fruit and/or parts of plants, e.g. rose hip. The taste of the drink varies according to which plants are used and how they are blended. Lots of fruit teas are also flavoured.
Dispensed temperature:
approx. 97 °C, brewing time:
approx. 8 minutes

The type of tea determines the preset temperature.
The respective dispensing temperatures are the ones that Miele recommends for making the types of tea concerned.

You can adjust the dispensing temperatures used for the individual teas by customising the brewing temperature (see “Parameters – Brewing temperature”). A temperature increment of approximately 2 °C makes a noticeable difference.

Whether you use loose tea leaves, blended tea or tea bags depends on your own personal preference.

Making drinks

Follow the instructions for making tea on the tea packaging.

The amount of tea required varies from one type of tea to another. Always follow the recommendations of the manufacturer on the packaging or of the retailer. You can adjust the amount of water according to the type of tea and the size of the cup (see “Portion size”).

TeaTimer

You can use the **TeaTimer** function to start a minute minder when making tea. There is a preset brewing time for the type of tea selected. You can adjust the preset brewing time (up to a maximum of 14:59 minutes). The changed brewing time is saved.



While the brewing time is counting down, you can continue to use the coffee machine as normal. After the brewing time has elapsed, a buzzer will sound and the  symbol will flash.

Setting the TeaTimer

You can choose between the following options:

- **Automatic:** The **TeaTimer** starts automatically once the water has been dispensed.
- **Manual:** Once the water has been dispensed, you have the option of starting the **TeaTimer**.

The drinks menu is displayed.

- Touch the  sensor.
- Select **Settings**  | **TeaTimer**.

- Select the setting you want and confirm with **OK**.

Making tea

Touch the  sensor to access the menu containing the various types of tea.

The drinks menu is displayed.

- Pour loose tea into a tea filter or similar, or take a tea bag from the packet.
- Place the tea filter or the tea bag in the tea cup.
- Place the tea cup under the central spout.
- Touch .
- Select the type of tea you want and confirm your choice with **OK**.

Hot water will be dispensed into the cup.

If the **TeaTimer | Automatic** setting has been selected, the minute minder for the brewing time will start running once the water has been dispensed.

Starting the TeaTimer manually

TeaTimer appears in the display as soon as the water has been dispensed.

- Touch **OK**.

The editor will open with a suggested time.

- Change the brewing time if required and confirm with **OK**.

After the brewing time has elapsed, a buzzer will sound and the  symbol will flash.

- Remove the tea filter or tea bag when the desired brewing time has elapsed.

Teapot

The **Teapot** function allows you to make a large quantity of tea (maximum of 1 litre). The type of tea selected determines the preset temperature.

The drinks menu is displayed.

Tip: Make sure that the water container has enough water inside it before starting the **Teapot** function.

- Place a sufficiently large container under the central spout.
- Touch the ☞ drinks sensor.
- Select **Teapot**.
- Select the type of tea and number of cups you want (3 to 8).

Cancelling a drink

- Touch the ☞ sensor.

Dispensing warm or hot water

You can choose between the following options:

- Hot water at approx. 90 °C
- Warm water at approx. 65 °C

The drinks menu is displayed.

- Place a suitable container underneath the central spout.
- Touch the ☐ sensor.
- Choose between warm or hot water.
- Confirm with **OK**.



Dispensing will start.

Expert mode

The Expert mode function allows you to change the portion size while the drink is being made. The setting will **not** be saved and will only apply for the current drink.

Switching Expert mode on and off

The drinks menu is displayed.



- Touch the  sensor.
- Select Settings  | Expert mode.
- Select the option you want.
- Confirm with *OK*.

The setting is now saved.

Expert mode: changing the portion size

The drinks menu is displayed.

The portion size can only be changed when the respective ingredient is being processed while the drink is being made.

If you select DoubleShot  or 2 portions , Expert mode cannot be used to change the portion size.

- Select a drink.

Dispensing will start. You can adjust the portion size while it is being dispensed, e.g. individually change the amount of hot milk, milk froth and espresso for a latte macchiato.

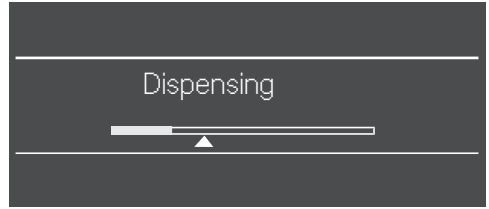

- Move the indicator (small triangle) across the navigation area according to the portion size you want.

The grinder setting determines the contact time between the ground coffee and the water, known as the extraction time. When the ideal grinder setting is selected, the machine dispenses a perfect cup of coffee with a fine, hazelnut-brown crema.

The grinder setting you select will be used for all coffee drinks.

There are various ways to tell whether the coffee grinder is set correctly.

The grinder setting is **too coarse** if the coffee or espresso is watery and tastes acidic. The crema is very pale.

Set a finer grinder setting.

The grinder setting is **too fine** if the coffee or espresso tastes too bitter and the crema is dark brown.

Set a coarser grinder setting.

Only adjust the grinder one setting at a time.

Start making a new drink to grind beans again. Adjust the grinder setting one setting at a time again.

Adjusting the fineness of grind

The slide control for adjusting the fineness is located on the top left behind the water container.

- Open the machine door.
- Remove the water container.

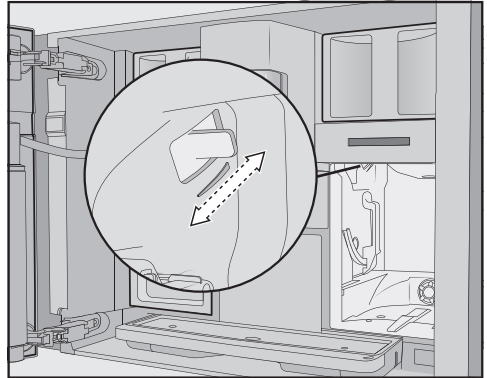

- Push the slide control a maximum of one setting forwards (for finer grinding) or one setting backwards (for coarser grinding).
- Replace the water container.
- Close the machine door.
- Make one cup of coffee.

Adjust the grinder setting again, if required.

Parameters

Displaying and changing parameters

You can change the portion size for all drinks.

In addition, you can set the “Amount of coffee”, “Brew temperature” and “Pre-brewing” parameters for each coffee drink individually.

- Touch the  sensor.
- Select a drink and confirm with *OK*.

The parameters that can be changed for this drink are displayed.

Once you have selected a drink, the current settings for the following appear: Amount of coffee, Brew temperature and Pre-brewing.

The Portion size menu option is displayed in the first line. If you select Portion size and confirm with *OK*, the drink will be dispensed immediately.

- Select the parameter you want.
- Change the setting as required and confirm with *OK*.

The setting is now saved.

Portion size

The flavour of the coffee produced depends not only on the type of coffee, but also on the amount of water used.

You can programme the amount of water for all drinks (apart from the Coffee pot function) to suit the size of your cups and/or the type of coffee you are using.

For coffee drinks that use milk, you can not only set the amount of espresso or coffee but also the amount of milk or milk froth to be dispensed with these drinks.

A maximum portion size can be programmed for each type of drink. Dispensing stops once this has been reached. The maximum possible portion size is then saved by the machine for this type of drink.

If the water container becomes empty whilst making a drink, the coffee machine will stop programming the portion size. The portion size will **not** be saved.

Changing the portion size

- Place a cup under the central spout.
- Select Portion size and confirm with *OK*.

The desired drink will be made and *Save* will appear in the display.

- When the cup is filled up to the level you want, touch *OK*.

If you want to change the portion size for coffee made with milk, the ingredients which make up the drink will be saved one after the other while the drink is being made.

- When the quantity for each ingredient reaches the level you want, touch *OK*.

The programmed portion size will now be dispensed every time that particular drink is selected.

Tip: For the drinks pictured on the control panel, you can change the portion size by pressing and holding the button down while the drink is being dispensed. To do this, keep the drinks sensor pressed until the machine starts dispensing. During dispensing, *Save* appears in the display.

Quantity of coffee

The coffee machine can grind and brew 7.5–12.5 g of coffee beans per cup. The greater the quantity, the stronger the coffee.

The quantity of coffee is **too low** if the espresso or coffee lacks body.

Increase the quantity of coffee so that more ground coffee is brewed.

The quantity of coffee is **too high** if the espresso or coffee tastes bitter.

Decrease the quantity of coffee so that less ground coffee is brewed.

Brewing temperature

The brewing temperature must be adapted to the beans you are using and how they are roasted. It also varies depending on whether you are making espresso or coffee.

Some bean types are sensitive to high brewing temperatures, resulting in an impaired taste. If your coffee tastes bitter, the brewing temperature you have selected might be too high.

Espresso is usually brewed at higher temperatures.

You can also adjust the brewing temperature for making tea and dispensing warm and hot water.

Pre-brewing the ground coffee

When the pre-brewing function is turned on, the ground coffee is first moistened with a little hot water. The ground coffee swells a little. The remaining amount of water is then pressed through the moistened coffee grounds shortly after. If your coffee tastes too bland and you want to add some spice and richness, try the “Pre-brewing” function. Depending on the type of coffee used, pre-brewing can intensify the taste.

You can set a short or long duration for pre-brewing or turn the “Pre-brewing” function off completely.

Tip: We particularly recommend using the “Pre-brewing” function to make coffee.

Profiles

In addition to the Miele drinks menu (Miele profile), you can create individual profiles to cater for different tastes and preferences.

Within the profile, you can adjust the portion sizes and parameters individually for all drinks.

The name of the current profile is shown in the top left of the display.



Creating a profile

- Touch the  sensor.

The Profiles menu opens.

- Select **Create profile** and confirm with **OK**.

The editor will open in the display.

- Enter the profile name:
 - To enter a character, highlight the one you want and confirm your choice with **OK**.
 - To delete a character, touch the  sensor.
 - To save the name, select the tick  and confirm with **OK**.

The profile has been created.

Changing drinks within a profile

When you change the parameters of a drink within a profile, these settings only apply to the active profile. The settings for drinks contained within other profiles remain unaffected.

- Select the profile you want.

The name of the selected profile is shown in the top left of the display.

You can now change the drinks individually.

Making drinks stored in a profile

- Touch the  sensor.
- Select the profile you want.
- Select the drink you want.

The machine starts dispensing the drink.

Editing profiles

Once you have created at least one profile, you can rename, delete or set when the profile should change in the Profiles menu.

- Select **Edit** and confirm with **OK**.

You can now edit the selected profile.

Setting when the profile should change

You can choose between the following options:

- **Manual:** The selected profile will remain active until you select another one.
 - **After each use:** The machine will revert to the Miele profile whenever a drink is dispensed.
 - **When switched on:** The Miele profile will be displayed whenever the coffee machine is switched on, regardless of which profile was selected before the machine was last switched off.
- Select **Change profile** and confirm with **OK**.

- Select the option you want and confirm with *OK*.

Changing the name

This option can only be selected if a profile has been allocated in addition to the Miele standard profile.

- Select *Change name* and confirm with *OK*.
- Change the name as required:
 - To delete a character, touch the ↵ sensor.
 - To enter a new character, highlight the one you want and confirm your choice with *OK*.
 - To save the modified name, select the tick ✓ and confirm with *OK*.

Deleting a profile

This option can only be selected if a profile has been allocated in addition to the Miele standard profile.

- Select *Delete profile* and confirm with *OK*.
- Select the profile you wish to delete.
- Select *Yes* and confirm with *OK*.

The profile will be deleted.

MobileStart

With MobileStart you can, for example, start making a drink via the Miele app.

You will only be able to use MobileStart if Miele@home has been set up for your coffee machine.

 Danger of burning and scalding on the dispensing spouts.

If liquids or steam are dispensed while the machine is unsupervised, persons may burn themselves if they place body parts under the central spout or touch hot components.

Ensure that no one, especially children, can be harmed if the machine is operated without supervision.

The pipework is not pre-warmed when the machine is switched on, meaning that the cup under the central spout is not filled with rinse water.

Milk is not cooled in the milk container. If you want to start making a drink with milk using the app, make sure that the milk is sufficiently cold ($< 10\text{ }^{\circ}\text{C}$).

If the coffee machine is being operated manually, it cannot be operated via the app. Operation on the appliance takes precedence.

To start making drinks remotely, MobileStart must be activated. Make sure that the coffee machine is ready to use, for example check that the water container is sufficiently filled. Place a sufficiently large, empty cup under the central spout.

MobileStart will be deactivated after 24 hours.

If you are making a drink with MobileStart, you will be notified of drink dispensing with acoustic and optical signals. These signals cannot be changed or switched off.

Switching MobileStart on and off

If you want to use Mobile Start, the Remote control option must be switched on.

The drinks menu is displayed.



- Touch the  sensor.
- Select Mobile Start.
- Select the option you want and confirm with *OK*.

Once you have switched on Mobile Start, you can now start making a drink via the app. Follow the prompts for doing this.

You can use the “Settings” menu to customise the coffee machine to suit your requirements.

Displaying and changing Settings

The drinks menu is displayed.

- Touch the  sensor control.
- Select Settings  and touch **OK**.
- Select the menu option that you want to display or change.
- Confirm with **OK**.
- Change the setting as required and confirm with **OK**.

Some settings which can be found in the Settings menu are described in their separate sections in the operating instructions.

Language

You can select the language (and location variant of that language) for all display text.

Tip: If you select the wrong language by mistake, you can find the “Language” option again via the  symbol.

Time

Display (Clock display)

Select how you want the time of day to show in the display when the coffee machine is switched off:

- **On:** The time is always visible in the display.
- **Off:** The time is not visible in the display.

- **Night dimming:** To save energy, the time is only displayed between 5 am and 11 pm.

Clock format

- 24-hour display (24 h)
- 12-hour display (12 h)

Setting

Set the hours and the minutes.

If the coffee machine has been connected to a WiFi network and is signed into the Miele app, the time will be synchronised based on the location setting in the Miele app.

Date

Set the date.

Timer

The coffee machine has 2 timers offering the **Switch on at** and **Switch off at** timer functions.

You can allocate the individual timer functions to different days of the week.

Switch on at

The coffee machine switches on at a particular time, e.g. in the morning for breakfast.

The coffee machine will **not** switch on at the required time if you have activated the system lock. The timer settings are deactivated.

Once the coffee machine has come on automatically **three times** at the set time without any drinks being dispensed, it will stop switching on automatically. This prevents the coffee

Settings

machine from switching itself on unnecessarily, for example, whilst you are away on holiday.

The programmed times will, however, remain in the memory and will be reactivated when the machine is next switched back on manually.

If you have set the time to be displayed while the machine is switched off (Show | On or Night dimming), the  symbol and the desired switching-on time will appear in the display 23:59 hours beforehand.

Switch off at

The coffee machine switches off at a particular time.

In the event of a longer absence, the programmed times will remain in the memory and will be reactivated when the machine is next switched back on manually.

Switch off after

The coffee machine switches off after a particular length of time if no sensors have been pressed.

By default, the coffee machine switches off after 20 minutes.

You can change this to another time of between 20 minutes and 9 hours.

TeaTimer

You can use the TeaTimer to start a minute minder when making tea (see “Making drinks – TeaTimer”).

Volume

You can set the volume of the buzzer and keypad tones (segment bar).

The welcome melody that plays when you touch the On/Off button  can be switched on or off.

Display brightness

You can set the display brightness (segment bar).

Lighting

You can change the brightness of the lighting while the coffee machine is switched on or off.

You can also specify how long the lighting should stay on for when the machine is switched off (adjustable between 15 minutes and 9 hours).

Info (display information)

You can display the number of drinks dispensed so far and how many more can be dispensed until the maintenance programmes have to be run.

Fresh water

The machine is intended to be plumbed into the mains water supply. Fresh water is automatically taken into the water container when the mains water connection is on. If it is switched off, you must fill the water container manually.

Altitude

If the coffee machine is installed at high altitudes, the lower air pressure will cause the water to boil at a lower temperature. You can set the local altitude of the machine to ensure that the correct temperatures are achieved.

Performance mode

You can select the appropriate performance mode for how you use your machine. Eco mode is set by default.

Eco mode

Eco mode is an energy-saving mode. The system does not heat up until someone starts making a drink.

Barista mode

This performance mode has been optimised for unadulterated coffee enjoyment. Users can enjoy coffee-based drinks without any delay as the coffee machine remains heated to the brewing temperature. This mode consumes more energy than Eco mode.

Latte mode

This performance mode has been optimised for preparing milk. Milk-based drinks can be prepared within a much shorter space of time. This mode consumes more energy than Eco mode and Barista mode.

Party mode

This performance mode has been configured for the **occasional** intensive use of the coffee machine, e.g. for family get-togethers.

Clean the coffee machine thoroughly after intensive use, particularly the milk pipework. It may be necessary to descale the coffee machine and degrease the brew unit.

Please note the following information about Party mode:

- The general pipework is rinsed much less frequently or not at all. The milk pipework is not rinsed until around 1 hour after milk was last dispensed.
- Cleaning status messages or cleaning prompts are suppressed and delayed until the machine is next switched on.
- The Switch off at and Switch off after timers are deactivated. The coffee machine switches off 6 hours after the last sensor was pressed.
- The cup light remains permanently switched on at the maximum brightness level for as long as the coffee machine stays switched on.

Water hardness

Programme the coffee machine to the water hardness level of your area so that it functions correctly and does not get damaged.

Contact your local water supplier to find out your local water hardness range if necessary.

If you are using bottled drinking water, e.g. mineral water, select settings according to the calcium content. The calcium content is specified on the label of the bottle in mg/l Ca²⁺ or ppm (mg Ca²⁺/l).

Do not use carbonated water.

The hardness level is set to 21 °dH by default.

Settings

Water hardness		Calcium content mg/l Ca ²⁺ or ppm (mg Ca ²⁺ /l)	Setting s
°dH	mmol/l		
1	0.2	7	1
2	0.4	14	2
3	0.5	21	3
4	0.7	29	4
5	0.9	36	5
6	1.1	43	6
7	1.3	50	7
8	1.4	57	8
9	1.6	64	9
10	1.8	71	10
11	2.0	79	11
12	2.1	86	12
13	2.3	93	13
14	2.5	100	14
15	2.7	107	15
16	2.9	114	16
17	3.0	121	17
18	3.2	129	18
19	3.4	136	19
20	3.6	143	20
21	3.8	150	21
22	3.9	157	22
23	4.1	164	23
24	4.3	171	24
25	4.5	179	25
26	4.6	186	26
27	4.8	193	27
28	5.0	200	28
29	5.2	207	29

Water hardness		Calcium content mg/l Ca ²⁺ or ppm (mg Ca ²⁺ /l)	Setting s
°dH	mmol/l		
30	5.4	214	30
31	5.5	221	31
32	5.7	229	32
33	5.9	236	33
34	6.1	243	34
35	6.3	250	35
36	6.4	257	36
37–45	6.6–8.0	258–321	37–45
46–60	8.2–10.7	322–429	46–60
61–70	10.9–12.5	430–500	61–70

Tip: If your water hardness is >21 °dH (3.8 mmol/l), we recommend using bottled drinking water instead (< 150 mg/l Ca²⁺). This will mean your coffee machine will need to be descaled less often and there will be less impact on the environment because less descaler will be used.

System lock

You can lock the coffee machine to prevent it being used without your knowledge, by children, for example.

When the system lock is activated, the settings for the Switch off after timer are deactivated. The coffee machine will **not** switch on at the time set.

Temporarily deactivating the system lock

- Press and hold OK for 6 seconds.

The system lock is reactivated when the coffee machine is next switched off.

Miele@home

The following options may appear under Miele@home:

- **Set up**: This option only appears if the coffee machine has never been connected to a WiFi network or if the network configuration has been reset.
- **Deactivate*/Activate***: The settings for the WiFi network are retained, but the network is switched on or off.
- **Connection status***: Information about the WiFi connection is displayed. The symbols indicate the strength of the connection.
- **Set up again***: The settings for the current WiFi network will be reset. The WiFi connection will be set up from scratch.
- **Reset***: The WiFi is switched off and the settings for the current WiFi network will be reset.

The network configuration should be reset whenever the coffee machine is being disposed of or sold, or if a used coffee machine is being put into operation. This is the only way to ensure that all personal data has been removed and the previous owner will no longer be able to access the coffee machine.

* This menu option appears if Miele@home has been set up and the coffee machine has – where applicable – been connected to a WiFi network.

Remote control

The remote control option appears when the coffee machine is connected to a WiFi network.

You can change the coffee machine settings, for example, in the Miele app when remote control is switched on. To start making a drink via the app, MobileStart must be activated as well.

The remote control function is switched on by default.

RemoteUpdate

The RemoteUpdate menu option is only displayed and can only be selected if the requirements for using Miele@home have been met.

The RemoteUpdate function allows the software on your coffee machine to be updated. If an update is available for your coffee machine, it will automatically download it. Updates will not be installed automatically. They must be initiated manually.

If you do not install an update, you can continue to use your coffee machine in the usual way. However, Miele recommends installing updates.

Activating/deactivating

The RemoteUpdate function is activated by default. Available updates will be downloaded automatically but will only be installed if you initiate installation manually.

Deactivate RemoteUpdate if you do not want any updates to be downloaded automatically.

Settings

Running a RemoteUpdate

Information about the content and scope of an update is provided in the Miele app.

A message will appear in your coffee machine display if a software update is available.

You can install the update immediately or postpone this until later. When the coffee machine is switched on again, you will be reminded about the update.

Deactivate RemoteUpdate if you do not want to install the update.

The update may take several minutes.

Please note the following information about the RemoteUpdate function:

- You will only receive a message when an update is available.
- Once an update has been installed, it cannot be undone.
- Do not switch the coffee machine off during the update. Otherwise, the update will be aborted and will not be installed.
- Some software updates can only be carried out by the Miele Customer Service Department.

Software version

The “Software version” menu option is intended for the Miele Customer Service Department. You do not need this information for domestic use.

Showroom programme (Demo mode)

Do not activate this function for domestic use.

The Showroom programme | Demo mode function enables the coffee machine to be demonstrated in shops or showrooms. In this mode, the appliance lights up but no drinks can be prepared and no maintenance programmes can be run.

You can activate demo mode without commissioning the appliance for the first time. Switch the coffee machine on and off again. Press the ↵ control for 5 seconds straight away. Demo mode is activated.

Factory defaults

You can reset the coffee machine to its factory default settings.

The following will **not** be reset:

- The number of drinks dispensed and the machine status (No. of portions until machine needs descaling, ... brew unit needs degreasing)
- Language
- Time and date
- Profiles and the associated drinks
- Miele@home



Risk to health due to inadequate cleaning

Heat and moisture inside the coffee machine can cause coffee residues to become mouldy and/or milk residues to go off and pose a risk to health.

Carefully clean the coffee machine regularly.

Overview of cleaning intervals

Recommended frequency	What do I have to clean/maintain?
Daily (at the end of the day)	Milk flask and lid
	Milk valve
	Water container
	Drip tray cover
	Drip tray and waste container
Once a week (more often if heavily soiled)	Central spout
	Cup rim sensor
	Interior cabinet
	Brew unit
	Drip tray
	Appliance front
Once a month	Remove and clean the milk valve
	Bean container
As and when required / after prompt appears in display	Milk pipework (using the cleaning agent for milk pipework)
	Degrease the brew unit (using cleaning tablets)
	Descale the appliance

Cleaning and care

Cleaning by hand or in the dishwasher

The brew unit is **not** dishwasher safe.

Clean the brew unit by hand only under warm running water. **Do not use washing-up liquid or any other cleaning agent.**

The following components must be cleaned **by hand only**:

- Central spout stainless steel cover
- Brew unit
- Bean containers and lids

 Risk of damage as a result of excessively high dishwasher temperatures.

Components may be ruined (e.g. may become warped) if washed in a dishwasher at temperatures higher than 55 °C.

For dishwasher-safe components, always select dishwasher programmes with a maximum temperature of 55 °C.

Contact with natural dyes such as those found in carrots, tomatoes and ketchup may discolour the plastic parts in the dishwasher. This discolouration does not affect the stability of the parts.

The following components are **dishwasher safe**:

- Drip tray, lid and waste container
- Drip tray cover
- Central spout (without stainless steel cover)
- Milk flask and lid
- Cup sensor
- Drip tray
- Maintenance container
- Water container

 Danger of burning and scalding on hot components or by hot liquids. Components can become very hot during operation. Touching hot components can cause burning. The liquids and steam dispensed are very hot and can cause scalding. Keep well away from the area underneath the spouts when hot liquids and steam are being dispensed. Always allow the coffee machine to cool down before cleaning it. Please be aware that water in the drip tray can also be very hot.

 Risk of damage due to moisture ingress. The steam from a steam cleaning appliance could reach live electrical components and cause a short circuit. Do not use a steam cleaner to clean the coffee machine.

It is important to clean the machine regularly, as the used coffee grounds will soon go mouldy. Milk residues can go off and can block the milk pipework.

Unsuitable cleaning agents

Contact with unsuitable cleaning agents can alter or discolour the external surfaces. All surfaces are susceptible to scratching. Scratches on glass can in some circumstances lead to breakage.

Remove all cleaning agent residues immediately. To protect the machine and surrounding surfaces from damage, make sure you remove any spillages or splashes of descaling agent immediately.

To avoid damaging the surfaces, do not use:

- Cleaning agents containing soda, ammonia, acids or chlorides
- Solvent-based cleaning agents
- Cleaning agents containing descaling agents (unsuitable for cleaning the front of the machine)
- Stainless steel cleaning agents
- Dishwasher cleaners (unsuitable for cleaning the front of the machine)
- Glass cleaning agents
- Cleaning agents for ceramic hobs
- Oven cleaners
- Abrasive cleaning agents, e.g. powder cleaners and cream cleaners
- Hard, abrasive brushes or sponges, e.g. pot scourers, brushes or sponges which have been previously used with abrasive cleaning agents
- Melamine eraser blocks
- Sharp metal scrapers

Cleaning and care

- Steel wool or stainless steel wire scourers

Cleaning the drip tray and waste container

 Danger of burning and scalding on hot components or by hot liquids. Components can become very hot during operation. Touching hot components can cause burning. The liquids and steam dispensed are very hot and can cause scalding.

If the pipework has just been rinsed, wait a while before removing the drip tray.

Please be aware that water in the drip tray can also be very hot.

Do not touch hot components.

Clean the drip tray and waste container **every day** to avoid unpleasant smells and mildew.

A prompt will appear in the display when the drip tray and/or the waste container is full and needs to be emptied. Empty the drip tray **and** the waste container. It is not necessary to take the lid off the drip tray in order to empty it.

Tip: If the drip tray is heavily soiled, clean it with a brush before placing it in the dishwasher.

- Open the appliance door.

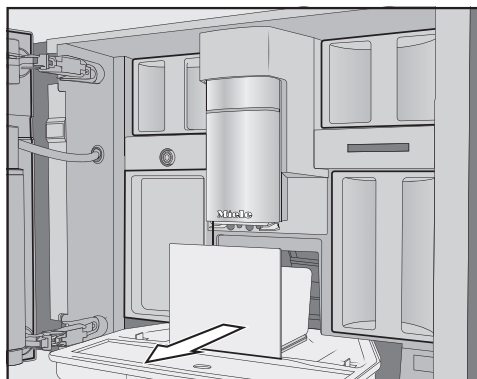

- Remove the drip tray and waste container from the machine.
- Empty the waste container after removing it from the drip tray.

The waste container may contain a small amount of water from rinsing as well as the leftover coffee grounds.

Taking the drip tray apart

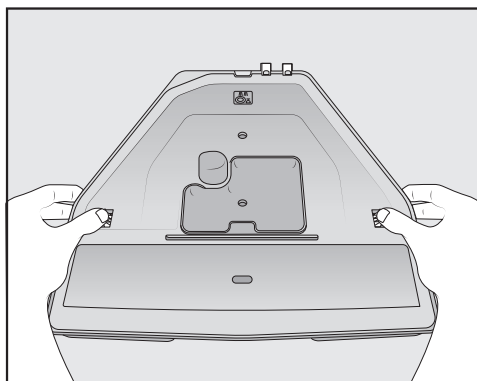

The orange clips are not removable.

- Take the lid off the drip tray as follows: press the orange clips outwards on both sides to release the lid. Remove the lid.

- Clean the drip tray, lid and waste container in the dishwasher or wash them by hand using warm water and a little washing-up liquid.
- Dry all parts thoroughly.
- Clean the inside of the coffee machine underneath where the drip tray goes.

Cleaning contacts

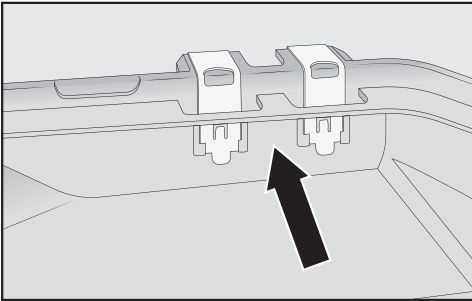

- Clean the contacts (metal discs) and the space between them carefully, e.g. using a brush. Dry all parts thoroughly.

The contacts will not be able to detect that the drip tray is full if they are damp or dirty. Check the contacts and the area around them once a week.

Reassembling the drip tray

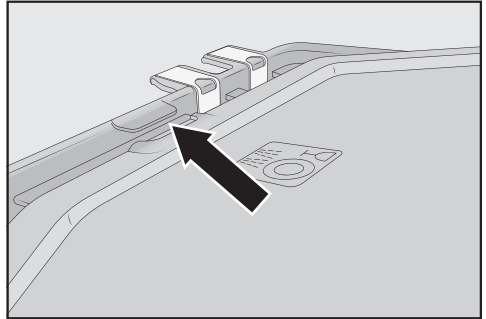

- Attach the drip tray lid as follows: slide the lid under the lug next to the contacts and apply pressure to the lid until the catches at the sides audibly click into place.

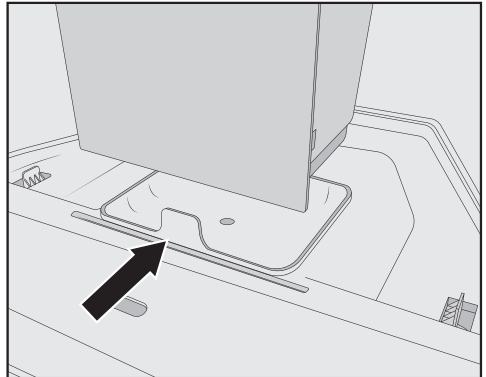

- Place the waste container on the lid.
- Push the drip tray and waste container back into the coffee machine. Close the appliance door.

Cleaning and care

Cleaning the drip tray cover

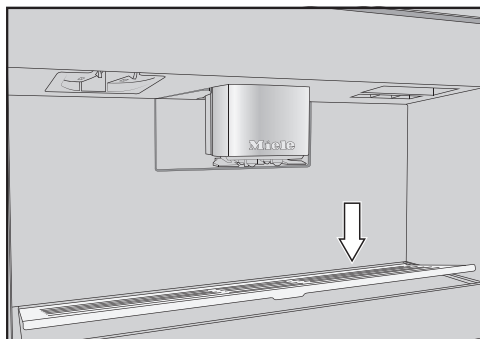

- Remove the drip tray cover as follows: apply pressure to the rear edge so that the cover tips forwards and you can remove it easily.
- The drip tray cover can be cleaned in the dishwasher, or by hand using warm water and a little washing-up liquid.
- Dry the drip tray cover.
- Refit the drip tray cover.

Water container

Clean the water container by hand every day with warm water and a little washing-up liquid. You can clean the water container in the dishwasher once a week.

- Open the machine door.
- Remove the water container.
- Clean and rinse the water container with clean water to remove any detergent residues. Dry the outside of the water container.



- Clean and dry the surface that the water container sits on.
- Push the water container all the way into the coffee machine until you feel a resistance. Close the machine door.

Cleaning the central spout

Clean the central spout's stainless steel cover by hand only, using warm water and a little washing-up liquid.

With the exception of the stainless steel cover, all parts of the central spout should be cleaned in the dishwasher at least **once a week**. This will remove coffee deposits and milk residues effectively.

- Open the appliance door.
- Pull the central spout's stainless steel cover forwards to remove it. Then clean it.

Cleaning and care

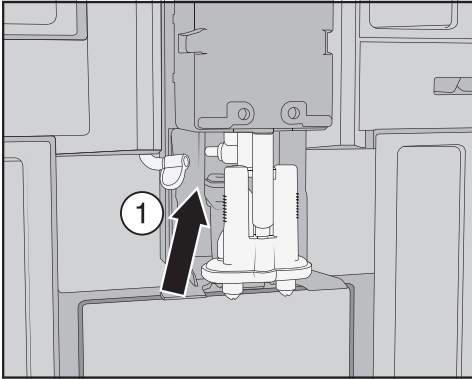

- Detach the milk pipework from the dispensing unit as follows: pull the tab ① to the left.

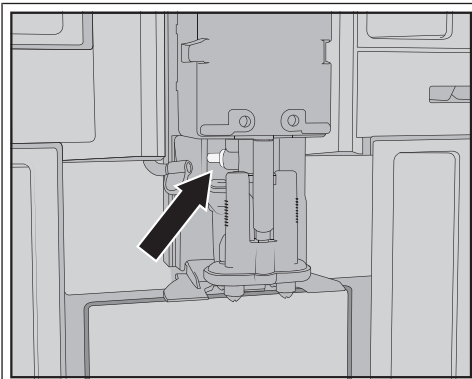

Do not remove the milk pipework connecting piece. If necessary, clean the connecting piece with the cleaning brush.

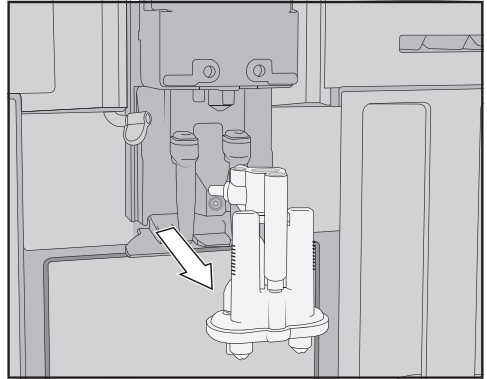

- Grip the dispensing unit by the sides and pull it down to remove it.

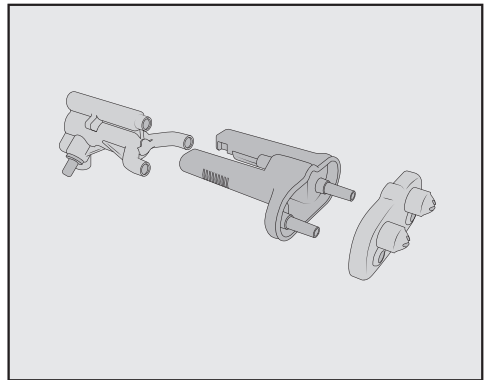

- Take the dispensing unit apart, separating it into 3 components: the Y-piece, the spouts and the holder.
- Clean all parts thoroughly.

Cleaning and care



- Clean the area around the central spout with a damp cloth.

Reassembling the central spout

The dispensing unit is easier to reassemble if the individual parts are dampened with water beforehand.

Make sure that all parts are tightly connected to one another.

- Fit the dispensing unit back together. Press down firmly so that the spouts become securely connected to the holder.

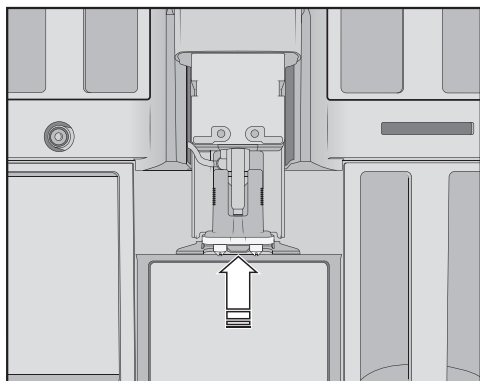

- Insert the dispensing unit into the coffee machine and connect the milk pipework.

- Refit the stainless steel cover.
- Close the appliance door.

Fit cover to central spout will appear in the display.

- Confirm the message with OK.

Cleaning the cup rim sensor

The cup rim sensor is located under the central spout.

Clean the cup rim sensor at least once a week and more often if heavily soiled.

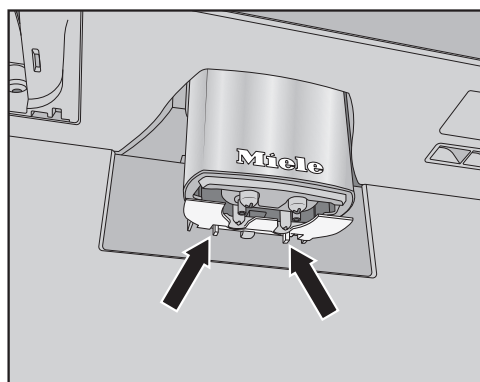

- Press the two retainers together (see arrows).

The cup rim sensor is released.

- The cup rim sensor can be cleaned in the dishwasher, or by hand using warm water and a little washing-up liquid.
- To refit the cup rim sensor, press it into the holder on the central spout from below.

Cleaning the milk flask with lid

The milk flask should be taken apart and cleaned every day after use.

Both the lid and the glass flask can be cleaned in the dishwasher, or by hand using warm water and a little washing-up liquid.

- Remove and empty the milk flask.

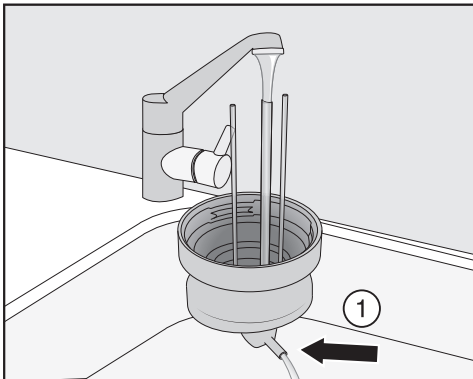

- Rinse the milk pipework in the lid under running water and then place the lid in the dishwasher.
- If no water runs out of the connecting piece ①, clean it with the cleaning brush.
- Clean the glass flask.
- Dry all parts and especially the threads on the lid and on the glass with a clean cloth. Reassemble the milk flask.

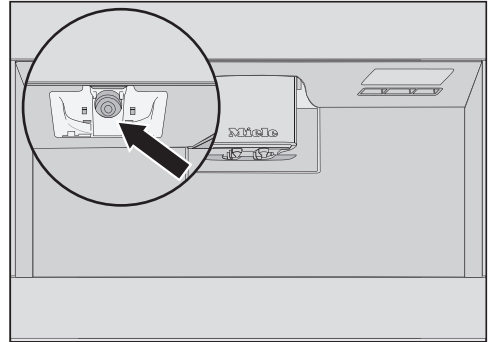

- Clean the milk flask holder on the coffee machine with a damp cloth.

Cleaning the milk valve (daily)

The milk valve seal can be damaged by objects with sharp edges or similar.

Do not use any sharp-edged objects (such as knives) to clean the milk valve.

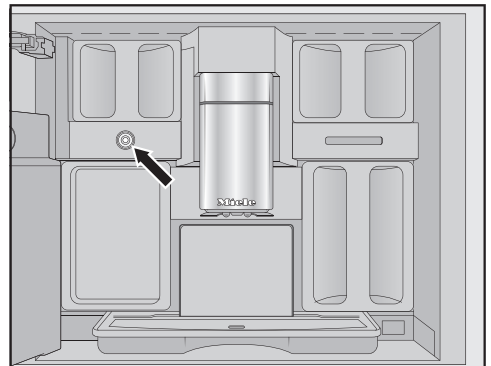

The milk valve is located under the bean container on the left-hand side.

If allowed to dry, milk residues can become encrusted on the stainless steel bolt. These crusty deposits are difficult to remove. Therefore, it is important to carry out regular cleaning after preparing milk.

Cleaning and care

- Open the appliance door.
- Clean the milk valve with a damp cloth/microfibre cloth.
- Close the appliance door.

Removing and cleaning the milk valve (once a month)

If the following issues occur during milk preparation, the milk valve may be blocked: only hot milk is dispensed instead of milk froth, the milk sprays out. Clean the milk valve more often if necessary.

The milk valve cover should only be cleaned **by hand**.

- Open the appliance door.
- Remove the bean container on the left and the maintenance container.
- Remove the central spout's stainless steel cover.



- Remove the milk valve cover: press on the recessed grip to unlock the cover.
On the top right-hand side of the cover, you will find a pin for swivelling the cover out.

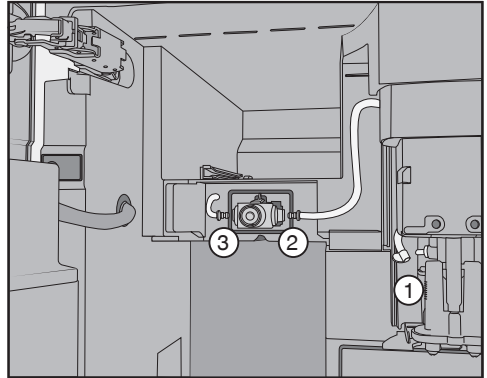

- Detach the milk pipework from the dispensing unit on the central spout ① and from the milk valve silicone seal (② and ③).
- Remove the milk pipework ① connecting the milk valve to the central spout.
- Disconnect the angular moulded hose from the round hose. Rinse the hoses thoroughly under running water.

Do **not** remove the connecting pieces from the hoses.

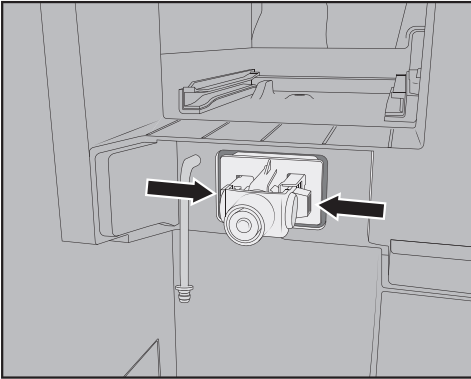

- Press the latches on the left and right-hand sides of the milk valve holder and pull the holder forwards to remove it.

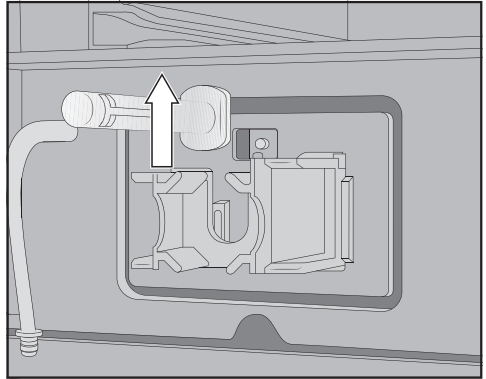

- Pull the stainless steel bolt upwards and out.
- Clean the individual components of the milk valve in the dishwasher.

Tip: If there are any dry milk residues on the front, soak the stainless steel bolt in warm water and a little washing-up liquid.

Fitting the milk valve

- Insert the stainless steel bolt from above.
- Insert the silicone seal into the milk valve holder.

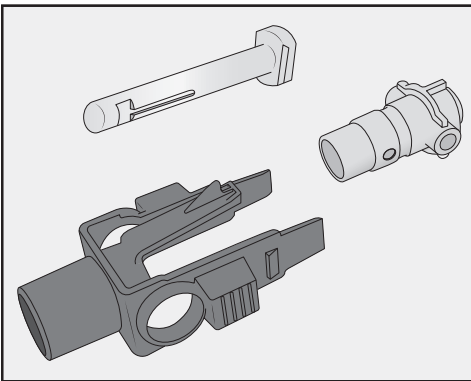

- Take the holder and silicone seal apart.

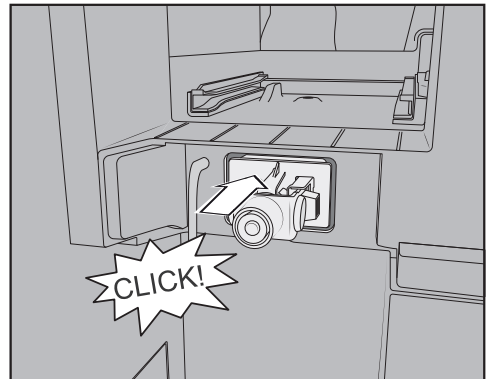

- Insert the holder and silicone seal until they audibly click into place.

Cleaning and care

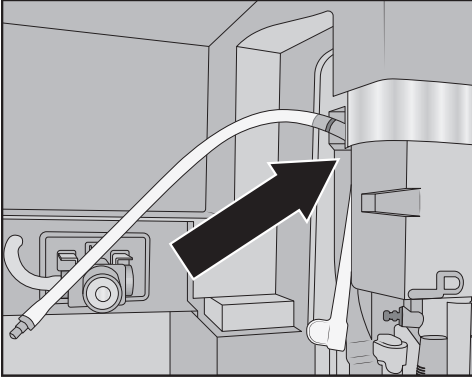

- Connect together the angular moulded hose and longer milk pipework. Start by attaching the moulded hose to the top of the central spout. The black connecting piece should be pointing to the rear.
- Then, connect the bottom end of the moulded hose to the dispensing unit.
- Insert the milk pipework into the milk valve on the left and right-hand sides. Push the connecting pieces into the silicone seal as far as they will go.
- Check that the milk pipework is snug against the housing and that the cover can be easily attached.

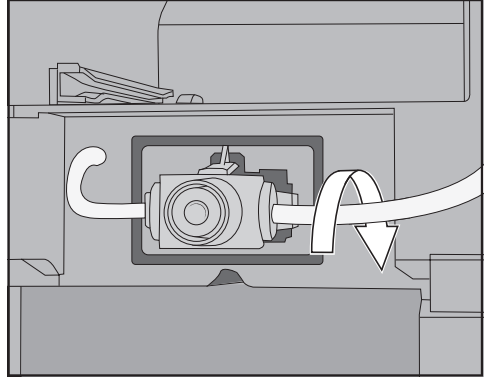

Tip: If necessary, turn the milk pipework towards the back at the connecting piece on the right-hand side.

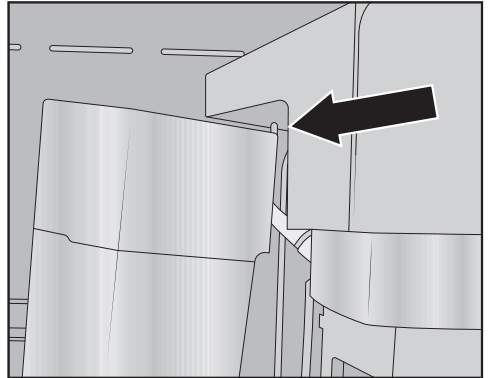

- Attach the milk valve cover as follows: insert the pin in the top right-hand corner and swivel the cover backwards until a proper fit is achieved.
- Push the left-hand bean container and maintenance container back into the coffee machine. Attach the central spout's stainless steel cover.
- Close the appliance door.

Cleaning the bean containers

 Risk of damage from incorrect use and cleaning.

Immersing the bean containers in liquids can result in malfunctions. If they are taken apart, bits may break off or the mechanism may no longer work properly once they are reassembled.

Do not disassemble the bean containers.

Do not immerse the bean containers in liquids, e.g. soapy water.

Coffee beans contain oils which can deposit themselves on the walls of the bean containers and hinder the flow of the beans. Therefore, clean the bean containers regularly with a soft cloth.

If required, you can clean the lids of the bean containers **by hand** with warm water and a little washing-up liquid. Dry the lids thoroughly before refitting them on the bean containers.

- Open the machine door.
- Pull the left and right-hand bean containers out of the coffee machine.
- Clean the bean container wells inside the machine.

Tip: Use a vacuum cleaner to remove any coffee residues from the interior.

- Remove the lids and empty the bean containers.

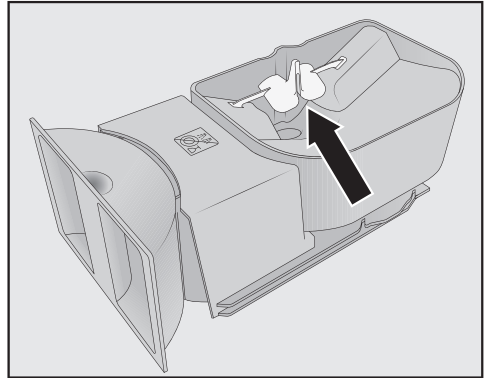

Do not remove the components for improving the flow of the beans (see arrow).

- Clean the bean containers and lids **by hand** using a slightly damp cloth. Dry all parts carefully before filling the bean containers with roasted coffee beans.
- Replace the lids and push the containers back into place in the coffee machine.
- Close the machine door.

Cleaning and care

Removing the brew unit and cleaning it by hand

The moving parts of the brew unit are lubricated. Cleaning agents will damage the brew unit.

Only clean the brew unit by hand with warm water. **Do not use any cleaning agents.**

Remove and clean the brew unit **once a week**. Also clean the area below the brew unit once a week.

- Open the appliance door.
- Remove the water container.

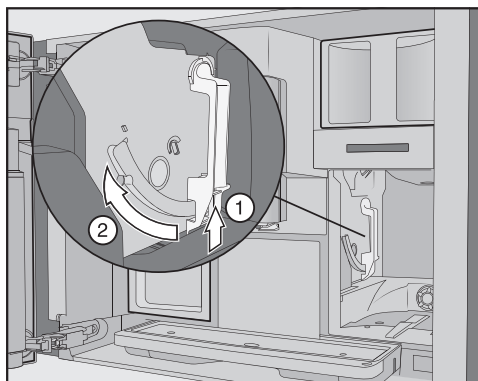

- Press the button under the handle of the brew unit ① and, whilst doing so, turn the handle forwards ②.

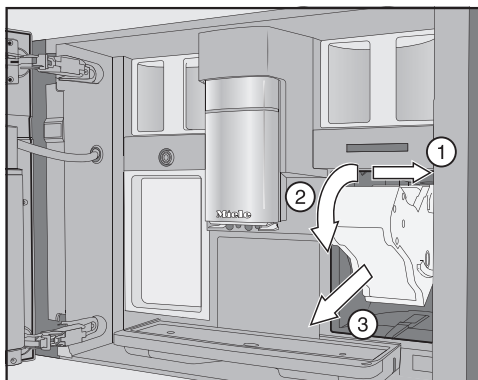

- First, pull the brew unit sideways ① and then slide it out forwards ③. Tilt the brew unit forwards ②.

If you cannot remove the brew unit or can only do so with difficulty, the brew unit is not in the correct position (see “Problem solving guide”).

When you have removed the brew unit, do **not** change the position of the handle on the brew unit. Otherwise, the brew unit cannot be reinserted.

- Clean the brew unit **by hand under warm running water** without using cleaning agent.

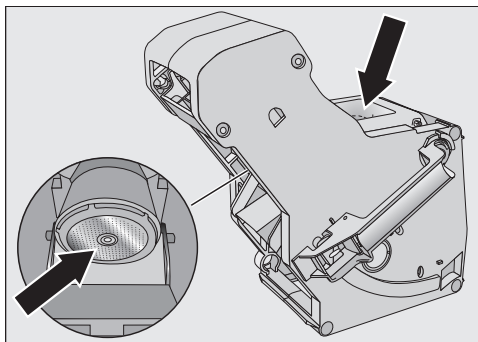

- Wipe any coffee grounds from the filters. One filter is located in the funnel. The other filter can be found to the left of the funnel.
- Dry the funnel to prevent ground coffee sticking to it the next time a coffee is made.

Cleaning the inside of the appliance

- Use your vacuum cleaner to remove dry coffee grounds.

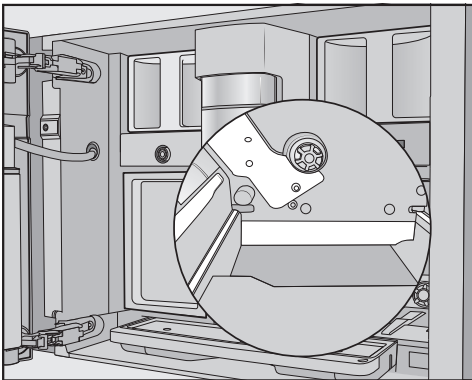

- Clean the niche of the brew unit with a damp, clean cloth. Clean the areas marked in white in the illustration, e.g. around the drive shaft, especially well.

Replacing the brew unit

- Proceed in the reverse order: push the brew unit back into the coffee machine. Tilt the brew unit forward a little when doing this.

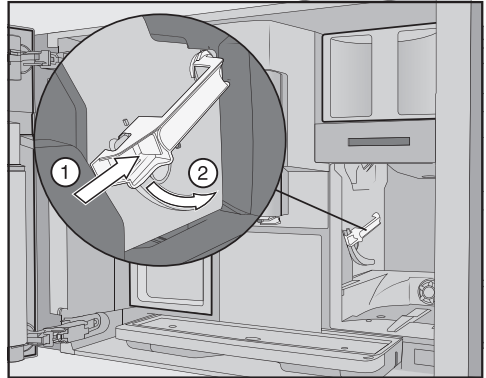

- Press the button under the handle of the brew unit ① and, whilst doing so, turn the handle backwards ②.

Tip: If you are unable to turn the brew unit handle, apply firm pressure to the sides of the brew unit.

- Push the water container into the coffee machine.

The process of removing and inserting the brew unit causes ground coffee to drop onto the drip tray.

- Remove the drip tray and clean the lid.
- Push the drip tray back into the coffee machine and close the machine door.

Cleaning the interior, inside of the machine door and drip tray

Clean the interior and front of the machine as part of the normal cleaning process. For instance, if you remove the water container, use this as an opportunity to clean the area under the water container at the same time.

Cleaning and care

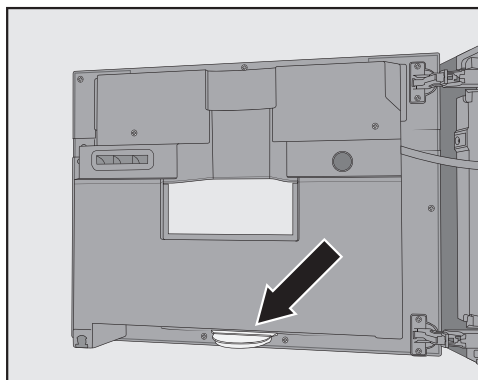

The drip tray is located at the bottom on the inside of the machine door.

Remove and empty the drip tray on a regular basis. The drip tray is dishwasher safe.

- Open the machine door.
- Remove and clean the drip tray.
- Remove the following parts from the interior:
 - Water container
 - Drip tray
 - Maintenance container
 - Brew unit
 - Bean containers

Tip: Use your vacuum cleaner to remove dry ground coffee residues.

- Clean the interior and the inside of the machine door by hand with a clean and slightly damp cloth/microfibre cloth. After cleaning, wipe the interior and machine door dry using a soft cloth.
- Put all the parts back in place, including the drip tray.

- Close the machine door.

Cleaning the front of the machine

If soiling is not removed promptly, it could cause the surface to alter or discolour.

Remove any soiling on the front of the machine straight away.

Make sure that water cannot get behind the display.

Clean the front of the machine after descaling. If possible, wipe up any spillages of descaling agent immediately.

Tip: Before cleaning the control panel, open the machine door to prevent accidental operation.

- Clean the front of the machine with a clean and slightly damp cloth/microfibre cloth. After cleaning, wipe the surfaces dry using a soft cloth.

Tip: You can also use a Miele microfibre cloth to clean the front.

Maintenance programmes

The coffee machine has maintenance programmes for:

- Rinsing the machine
- Rinsing the milk pipework
- Cleaning the milk pipework
- Degreasing the brew unit
- Descaling the machine

Run the relevant maintenance programme when the prompt to do so appears in the display. You can also start maintenance programmes at any time so that the coffee machine does not prompt mandatory cleaning at an inconvenient time.

Tip: To save you having to empty the drip tray too often, you can place the maintenance container under the central spout.

Opening the Maintenance menu

- Touch the  sensor.

You can now select a maintenance programme.

Rinse the appliance

If you have made a coffee drink, the coffee machine will rinse the coffee pipework automatically before switching off.

You can also start the Rinse the appliance function manually.

Rinse the milk pipework

If you have made a drink with milk, the coffee machine will rinse the milk pipework automatically after a few minutes. You can also start the Rinse the milk pipework function manually.

Cleaning the milk pipework

The milk pipework must be cleaned at least once a week.

The Clean the milk pipework maintenance programme lasts for approx. 15 minutes.

- Touch the  sensor control.
- Select Clean the milk pipework and touch **OK**.

The process will start and various messages will appear in the display.

- Follow the instructions in the display.

When Fill water container with lukewarm water and cleaning agent up to the cleaning mark  and replace it. Close the door appears in the display, proceed as follows.

Preparing the cleaning solution

For optimal cleaning results, we recommend Miele cleaning agent for milk pipework.

The cleaning agent for milk pipework has been specially developed for use with Miele coffee machines and prevents subsequent damage.

You can order the cleaning agent for milk pipework via the Miele webshop, the Miele Customer Service Department (see the end of this booklet for contact details) or from your Miele dealer.

Cleaning and care

- Add 2 sticks of the cleaning agent for milk pipework to the water container.

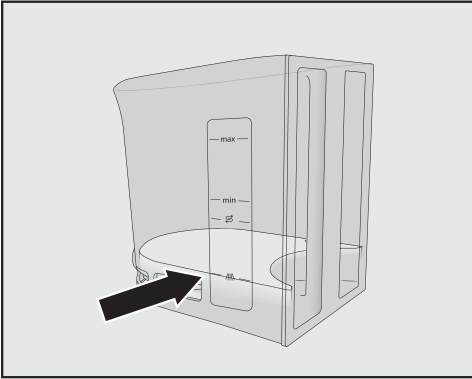

- Fill the water container to the // mark with lukewarm water and stir the solution.

Follow the instructions for the mixing ratio carefully. Fill the water container with the specified amount of water. Otherwise, cleaning will be incomplete.

- Replace the water container in the coffee machine and close the machine door.
- Follow the instructions in the display.
- If prompted to do so in the display, rinse the water container thoroughly with clean water. Make sure that **no** cleaning agent is left in the water container. Fill the water container with drinking water.

The cleaning process is complete when the drinks menu appears.

Degreasing the brew unit and cleaning the interior

Depending on the natural oil content of the coffee used, the brew unit can become blocked quite quickly. It must be degreased regularly in order to ensure aromatic coffee and trouble-free operation of the coffee machine.

We recommend using Miele cleaning tablets to clean the brew unit. These have been specially developed for degreasing the brew unit in Miele coffee machines and prevent subsequent damage.

The cleaning tablets are available to order via the Miele webshop, the Miele Customer Service Department (see the end of this booklet for contact details) or from your Miele dealer.

The maintenance programme for degreasing the brew unit lasts for approx. 10 minutes.

You need 1 cleaning tablet for the maintenance programme.

After 200 portions have been dispensed, a message prompting you to degrease the brew unit will appear in the display.

- Confirm the message with **OK**.

This message will keep being displayed until the brew unit has been degreased.

Degreasing the brew unit

- Touch the  sensor.
- Select **Degrease the brew unit** and touch **OK**.

The maintenance programme will then start.

- Follow the instructions in the display.

Remove the water container and the brew unit. Clean the interior of the machine. Rinse the brew unit by hand and refit it with a cleaning tablet in it. **will appear in the display.**

Cleaning the brew unit and interior

The moving parts of the brew unit are lubricated. Cleaning agents will damage the brew unit.

Only clean the brew unit by hand with warm water. **Do not use any cleaning agents.**

To ensure good tasting coffee and to prevent the formation of microbes in the machine, remove and clean the brew unit under running water once a week.

- Open the appliance door.
- Remove the water container.

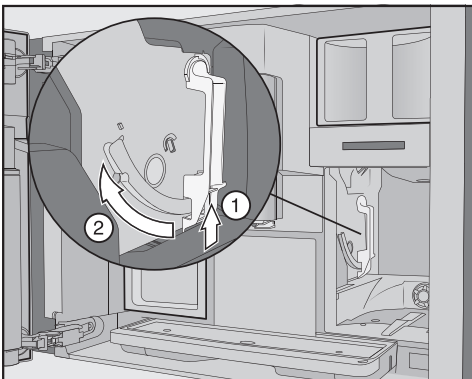

- Press the button under the handle of the brew unit ① and, whilst doing so, turn the handle forwards ②.

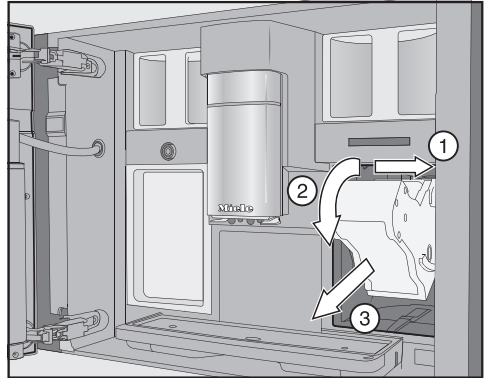

- First, pull the brew unit sideways ① and then slide it out forwards ②. Tilt the brew unit forwards ③.

If you cannot remove the brew unit or can only do so with difficulty, the brew unit is not in the correct position (see “Problem solving guide”).

When you have removed the brew unit, do **not** change the position of the handle on the brew unit. Otherwise, the brew unit cannot be reinserted.

- Clean the brew unit **by hand under warm running water** without using cleaning agent.

Cleaning and care

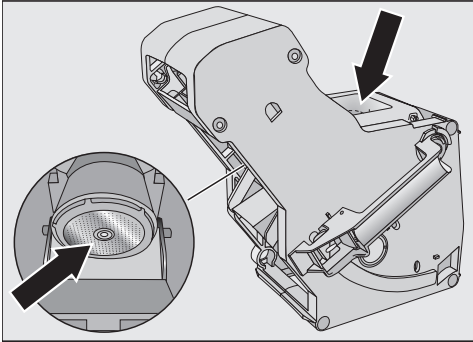

- Wipe any coffee grounds from the filters. One filter is located in the funnel and the other to the left of the funnel.

The process of removing the brew unit causes ground coffee to drop onto the drip tray.

- Remove the drip tray and clean the lid.
- Clean the interior of the coffee machine (see also “Cleaning and care – Removing the brew unit and cleaning it by hand”). Use your vacuum cleaner to remove dry ground coffee residues.

Dropping a cleaning tablet into the brew unit

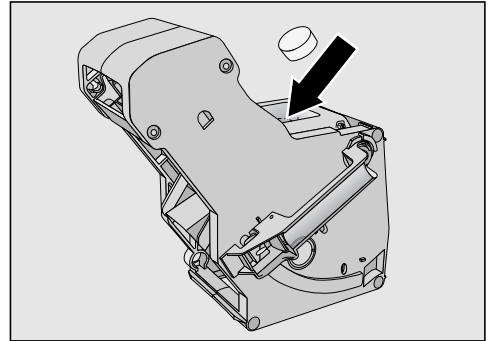

- Drop a cleaning tablet into the top of the brew unit (arrow).
- Push the brew unit containing the cleaning tablet back into the coffee machine.

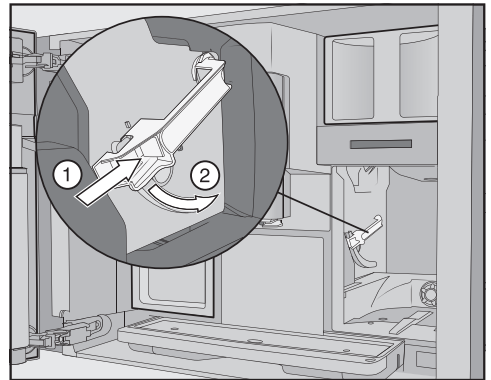

- Press the button under the handle of the brew unit ① and, whilst doing so, turn the handle backwards ②.
- Push the water container and drip tray (plus waste container) back into the coffee machine.
- Close the machine door.
- Follow the further instructions given in the display.

The cleaning process is complete when the drinks menu appears.

Descaling the machine

Risk of damage from spilt descaling solution.

Sensitive surfaces and/or natural floors can suffer damage.

Wipe up any spillages of descaling agent immediately.

Limescale builds up in the coffee machine through use. How often the appliance needs to be descaled will depend on the water hardness level in your area. Limescale must be removed regularly.

The appliance will guide you through the descaling process. Various messages will appear in the display, e.g. you will be prompted to empty the drip tray or fill the water container.

Descaling **must be carried out**. The process takes approx. 35 minutes.

The coffee machine will give you plenty of warning when it needs to be descaled. As of this point, the display will indicate how many more drinks can be made before descaling becomes absolutely essential. This number is indicated whenever a drink is made.

- Confirm the message with *OK*.

When the number of remaining portions reaches 0, the coffee machine will lock out.

You can switch the coffee machine off if you do not want to run the descaling programme at this point in time. You can not make any drinks until the machine has been descaled.

Descaling after prompt appears in the display

Descal the appliance will appear in the display.

- Confirm the message with *OK*.

The process will start.

- Follow the instructions in the display.

When Place 2 descaling tablets in the water container and fill it with lukewarm water up to the descaling symbol  and insert it. Close the door. **appears in the display**, proceed as follows.

Preparing the descaling solution

For optimum descaling results, we recommend using the Miele descaling tablets provided.

The descaling tablets have been specially developed for Miele coffee machines.

Other descalers, which contain other acids besides citric acid and/or other undesirable substances, such as chlorides for example, can cause damage to the product. Moreover, the descaling result required cannot be guaranteed if the descaling solution was not of the appropriate concentration.

Cleaning and care

Miele descaling tablets are available to order via the Miele webshop, from the Miele Customer Service Department (see the end of this booklet for contact details) or from your Miele dealer.

You will need **2** descaling tablets.

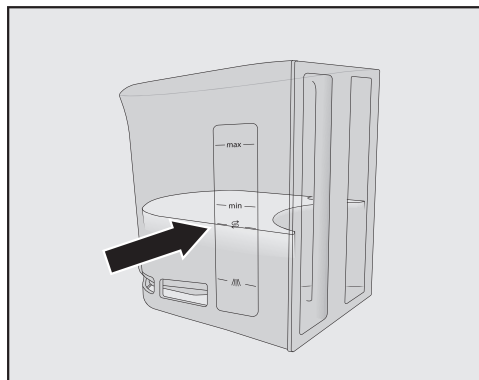

- Add **2** descaling tablets to the water container.
- Fill the water container to the S mark with lukewarm water.

Follow the instructions for the mixing ratio carefully. Fill the water container with the specified amount of water. Otherwise, descaling will be incomplete.

Carrying out descaling

- Push the water container back into the machine.
- Follow the further instructions given in the display.

When Rinse out and insert the water container. Close the door **appears in the display**:

- Remove the water container and rinse it thoroughly with clean water. Ensure that **no** descaling solution

residue remains in the water container. Fill the water container with tap water.

The descaling process is complete when the drinks menu appears.

Many malfunctions and faults that can occur in daily operation can be easily remedied. Time and money will be saved because a service call will not be needed.

The following guide may help you to find the reason for a malfunction or a fault, and to correct it.

Messages in the display

Error messages must be confirmed with *OK*, otherwise the message can reappear in the display even though the problem has been remedied.

Follow the instructions which appear in the display to remedy the problem.

If after this, the fault message appears in the display again, contact Miele Service.

Problem	Cause and remedy
F1, F2, F80, F82 F353, F354	There is an internal fault. ■ Switch the coffee machine off. Wait for approximately 1 hour before switching the machine back on again.
F74, F77 F225, F226 F235, F353, F354	There is an internal fault. ■ Switch the coffee machine off. Wait for approximately 2 minutes before switching the machine back on again.

Problem solving guide

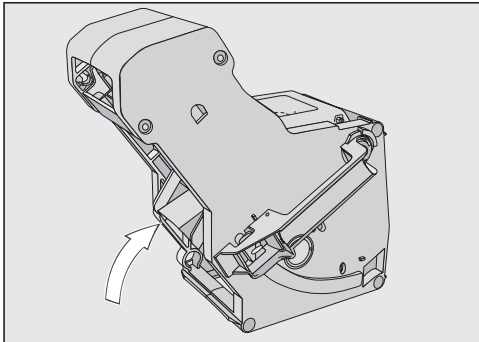
Problem	Cause and remedy
<p>F73 or Check the brew unit</p>	<p>The brew unit cannot be positioned correctly or is soiled. It is not possible to press the ground coffee.</p> <ul style="list-style-type: none"> ■ Check whether you can remove the brew unit. ■ If you can remove the brew unit, rinse it under running water.  <ul style="list-style-type: none"> ■ Push the coffee ejector of the brew unit into the correct position (see illustration). ■ Place the water container in the coffee machine and close the machine door. Do not insert the brew unit. Switch the coffee machine on. <p>This will initialise the brew unit motor and put it back into the start position.</p> <ul style="list-style-type: none"> ■ When Insert the brew unit appears in the display, put the brew unit back in the coffee machine. Close the machine door. ■ If you cannot remove the brew unit, switch the coffee machine off. Wait for approximately 2 minutes before switching the machine back on again.
<p>A maintenance programme is prematurely aborted and the following appears in the display: Push the water container in until it engages.</p>	<p>The water container has not been filled and inserted correctly.</p> <ul style="list-style-type: none"> ■ Check that you have selected the correct mark. <p>The symbols marked on the water container indicate the amount of water required for the</p> <p>Descale the appliance: ☉ and Clean the milk pipework: ☉ maintenance programmes.</p> <ul style="list-style-type: none"> ■ Fill the water container up to the relevant mark and restart the process.

Problem solving guide

Problem	Cause and remedy
<p>Check water intake and empty the water container</p>	<p>The mains water supply is not working.</p> <ul style="list-style-type: none"> ■ Check whether the water inlet hose is kinked or the stopcock is not turned on completely. ■ Remove and empty the water container. ■ Insert the empty water container into the coffee machine. <p>The following message is displayed: Please wait. Water container is being filled. The water container fills up.</p> <p>To turn off the mains water connection, fill and insert the water container. You can then select Settings : Mains water Off.</p>
<p>F233</p>	<p>The cup rim sensor is not inserted or is incorrectly inserted.</p> <p>If the central spout is moving upwards and the cup rim sensor is bumped, e.g. with a cup, the cup rim sensor loses its reference position.</p> <ul style="list-style-type: none"> ■ Confirm the message with <i>OK</i>. ■ Refit the cup rim sensor. <p>Cup rim detection remains inactive and the central spout stays in the top position until the coffee machine is next switched on. Cup rim detection is reinitialised during the next switch-on operation.</p>
<p>F 307 or Remove the milk valve and clean it</p>	<p>The milk valve is faulty.</p> <ul style="list-style-type: none"> ■ Remove and clean the milk valve (see “Cleaning and care – Removing and cleaning the milk valve”).

Problem solving guide

Unusual performance of the coffee machine

Problem	Cause and remedy
The display remains dark when the coffee machine is turned on using the On/Off button ①.	The On/Off button ① was not held for long enough. ■ Touch and hold the On/Off button ① for at least 3 seconds.
	The plug is not inserted in the socket correctly. ■ Insert the plug into the socket.
	The fuse has tripped because the coffee machine, voltage or another appliance is defective. ■ Switch off at the wall socket and remove the plug. ■ Contact a qualified electrician or the Miele Customer Service Department.
The lighting remains off after the coffee machine has been switched on.	The lighting has been switched off. ■ Switch the lighting on (see “Settings - Lighting”).
	The lighting is faulty. ■ Call Service.
The coffee machine does not respond to operation via the display.	There is a fault. ■ Touch and hold the On/Off button ① until the display switches off and the machine restarts.
The coffee machine turns off suddenly.	The factory set switch-off time (20 minutes) or the switch-off time you have programmed has been reached. ■ If required, you can select a new switch-off time (see “Settings – Timer”).
	The plug is not inserted in the socket correctly. ■ Insert the plug into the socket.
The sensors do not respond to touch. The coffee machine can no longer be operated.	There is an internal fault. ■ Disconnect the coffee machine from the power supply.
A fan can be heard even though no drinks are being prepared or the coffee machine is switched off.	This is not a fault. Once a drink has been dispensed or the machine has been switched off, the internal fan will continue to run until the interior is sufficiently dehumidified.

Problem solving guide

Problem	Cause and remedy
<p>The brew unit cannot be removed.</p>	<p>The brew unit is not positioned correctly.</p> <ul style="list-style-type: none"> ■ If necessary, move the handle on the brew unit back to the start position. Close the machine door. ■ Switch the coffee machine off. ■ Wait approx. 1 minute before switching the coffee machine back on. <p>This will initialise the brew unit motor and put it back into the start position.</p> <ul style="list-style-type: none"> ■ If necessary, repeat these steps.
<p>Coffee dispensing is repeatedly interrupted and the message <small>Fill the bean container</small> appears in the display.</p>	<p>This is not a fault.</p> <p>The brew unit has not detected the ground coffee. Certain types of coffee produce a small amount of coffee when they are ground. In such cases, the grinder is usually set to fine and the minimum quantity of coffee is set.</p> <ul style="list-style-type: none"> ■ Confirm the message with <i>OK</i>. <p>If the display appears with all types of coffee:</p> <ul style="list-style-type: none"> ■ Set the grinder to a coarser setting (see “Grinder setting”). ■ Select a larger quantity of coffee. <p>Don’t forget to check any drinks changed in “Profiles”.</p> <hr/> <p>If the message only appears when dispensing certain drinks:</p> <ul style="list-style-type: none"> ■ Check the quantity of coffee set for this drink (see “Quantity of coffee”). Select a larger quantity of coffee. ■ You may also need to set a coarser grinder setting.
<p>Drink dispensing is prematurely aborted even though there is a container under the central spout.</p>	<p>This is not a fault.</p> <p>If the container has a very wide opening that prevents the cup rim sensor from making contact with the edge of the container (e.g. in the case of a very large cup), the drink will be cancelled. Use a different container or position the existing one so that the sensor can detect the rim.</p>

Problem solving guide

Problem	Cause and remedy
The coffee machine does not switch itself on even though the timer setting has been activated. Switch on at timer setting	<p>The system lock has been activated.</p> <ul style="list-style-type: none">■ Deactivate the system lock. <p>The current day of the week has not been selected.</p> <ul style="list-style-type: none">■ Check the timer settings and change these if necessary. <p>The coffee machine was not used after being switched on automatically three times in succession (holiday mode).</p> <ul style="list-style-type: none">■ Switch the machine on and dispense a drink.
Steam is dispensed instead of water while preparing hot water or making tea.	<p>It is likely that the wrong altitude has been set.</p> <ul style="list-style-type: none">■ Change the altitude settings (Settings ▶ Altitude).■ If necessary, you can also change the temperature settings for the drinks (Parameters).
The display is hard to see or not able to be read.	<p>The display brightness has been set too low.</p> <ul style="list-style-type: none">■ Change this setting (see “Settings”).
The display lights up but the coffee machine does not heat up and no drinks are made.	<p>The demo mode for demonstrating the coffee machine in the showroom has been activated.</p> <ul style="list-style-type: none">■ Deactivate demo mode (see “Settings”).

Unsatisfactory results

Problem	Cause and remedy
<p>The coffee is not hot enough.</p>	<p>The cup has not been pre-heated. The smaller the cup and the thicker its sides, the more important it is to pre-heat it.</p> <ul style="list-style-type: none"> ■ Pre-heat the cup, for example, with hot water.
	<p>The brewing temperature has been set too low.</p> <ul style="list-style-type: none"> ■ Set a higher brewing temperature.
	<p>The filters in the brew unit are blocked.</p> <ul style="list-style-type: none"> ■ Remove the brew unit and clean by hand ■ Degrease the brew unit.
<p>The coffee grinder makes a louder noise than usual.</p>	<p>The coffee bean container has become empty during the grinding process.</p> <ul style="list-style-type: none"> ■ Fill the coffee bean container with fresh beans.
	<p>There may be foreign objects such as plastic or stones in amongst the coffee beans.</p> <ul style="list-style-type: none"> ■ Switch the coffee machine off immediately. Call Service.
<p>The coffee flows too quickly into the cup.</p>	<p>The coffee is too coarsely ground.</p> <ul style="list-style-type: none"> ■ Set the grinder to a finer setting (see “Grinder setting”).
<p>The coffee is dispensed too slowly into the cup.</p>	<p>The brew unit is blocked.</p> <ul style="list-style-type: none"> ■ Degrease the brew unit (see “Cleaning and care – Degreasing the brew unit and cleaning the interior”).
<p>There is no crema on the coffee or espresso.</p>	<p>The coffee beans are no longer fresh. If roasted coffee beans are stored open for too long, the carbon dioxide gradually escapes from the coffee beans. The crema is no longer formed during dispensing.</p> <p>Of course, you can still use the coffee beans.</p>

Problem solving guide

Problem	Cause and remedy
<p>The coffee tastes weak. The coffee grounds in the waste container are sludgy and grainy.</p>	<p>Less coffee is being brewed because insufficient coffee beans are getting into the grinder. Have you used a dark roast?</p> <p>This type of coffee bean is often more oily. These oils can cling to the inside of the bean containers and hinder the flow of beans.</p> <p>Are you using a type of coffee with very large beans or different sized beans?</p> <p>The beans are possibly getting wedged or jammed and forming “bean bridges”.</p> <ul style="list-style-type: none"> ■ Clean the bean containers more often if you are using darker, more oily coffee beans. ■ If you are using a type of coffee with very large beans or different sized beans, pull the bean containers out slightly and give them a shake. ■ If necessary, try using a different type of coffee.
<p>Coffee is not being dispensed from both spouts evenly. Milk may be sputtering when being heated up.</p>	<p>Coffee deposits in the central spout are obstructing dispensing.</p> <ul style="list-style-type: none"> ■ Take the central spout apart and wash all the components – with the exception of the stainless steel cover – in the dishwasher. This cleaning operation should be performed once a week.
<p>The consistency of the milk froth is unsatisfactory.</p>	<p>The milk temperature is too high. Good milk froth can only be achieved with cold milk (below 10 °C).</p> <ul style="list-style-type: none"> ■ Check the temperature of the milk in the milk flask. <p>The milk pipework is blocked and/or the milk valve is soiled.</p> <ul style="list-style-type: none"> ■ Remove and clean the milk valve.

Contact in the event of a fault

In the event of any faults which you cannot remedy yourself, please contact your Miele dealer or the Miele Customer Service Department.

You can book a Miele Customer Service Department call-out online at www.miele.com/service.

Contact information for the Miele Customer Service Department can be found at the end of this document.

Please quote the model identifier and serial number of your appliance (Fabr./SN/Nr.) when contacting the Miele Customer Service Department. This information can be found on the data plate.

Please note that telephone calls may be monitored and recorded for training purposes and that a call-out charge will be applied to service visits where the problem could have been resolved as described in this booklet.

Warranty

For information on the appliance warranty specific to your country please contact Miele. See back cover for address.

In the UK, your appliance warranty is valid for 2 years from the date of purchase. However, you must activate your cover by calling 0330 160 6640 or registering online at www.miele.co.uk.

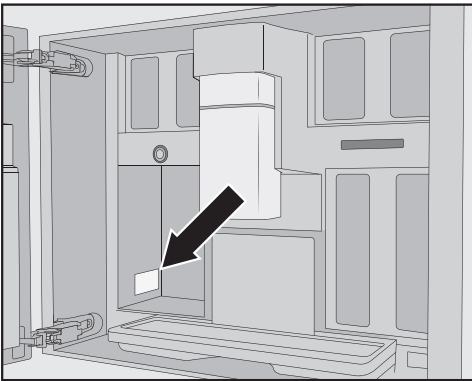

Accessories

These products and other useful accessories can be ordered via the Miele webshop, from Miele (see back cover for contact details) or from your Miele dealer.

- **Microfibre cloth**
for removing finger marks and light soiling
- **Cleaning agent for milk pipework**
for cleaning the milk system
- **Cleaning tablets**
for degreasing the brew unit
- **Descaling tablets**
for descaling the water pipework
- **CJ Jug 1.0 I**
Insulated flask for coffee or tea (pot function)
- **Miele Black Edition One for all**
Whole coffee beans – perfect for making espresso, café crema and speciality coffees with milk
- **Miele Black Edition Espresso**
Whole coffee beans – perfect for making espresso
- **Miele Black Edition Café Crema**
Whole coffee beans – perfect for making coffee
- **Miele Black Edition Decaf**
Whole coffee beans – perfect for making decaffeinated speciality coffees

Items supplied will vary depending on appliance and country. To find out which accessories and cleaning and care products are available in your country, please go to the website or contact the Miele Customer Service Department or your Miele supplier.

Mains water connection

 Risk of injury and appliance damage if appliance is not connected properly.

Failing to connect the appliance properly can result in personal injury and/or material damage.

The appliance may only be connected to the mains water connection by suitably qualified specialists.

 Risk to health and risk of damage due to contaminated water.

The quality of the incoming water must conform to the requirements for drinking water in the country where the coffee machine is being used.

Connect the coffee machine to the drinking water supply.

Connection to the water supply must comply with the applicable regulations in the country where the appliance is being installed. All appliances and systems used to supply water to the coffee machine must also comply with the applicable regulations in the respective country.

Connect the coffee machine directly to a fresh water pipe.

Avoid connecting the coffee machine to a water inlet in which the water might stagnate. Otherwise, the flavour of the drinks could be impaired.

The coffee machine meets the requirements of IEC 61770 and EN 61770.

The coffee machine may only be connected to a cold water supply.

The water connection pressure needs to be between 100 and 1000 kPa (1 and 10 bar).

A stopcock must be provided between the stainless steel hose and the household water inlet to ensure that the water supply can be cut off if necessary. Make sure the stopcock remains easily accessible once the coffee machine has been installed.

Fitting the stainless steel hose to the coffee machine

Only use the stainless steel hose supplied. The stainless steel hose must not be shortened, extended or replaced by a different hose.

A faulty stainless steel hose must only be replaced by a genuine original Miele replacement hose. The food-grade stainless steel hose is available to order via the Miele webshop or directly from Miele (see back cover for contact details).

The stainless steel hose supplied is 1.5 m long.

- Remove the cover cap from the mains water connection at the back of the coffee machine.
- Take the **angled** end of the stainless steel hose and check whether there is a washer. If there is no washer, fit one.
- Screw the coupling nut on the stainless steel hose onto the stopcock.

Installation

- Ensure that the threaded union is properly connected and does not leak.

You can now continue installing the coffee machine.

Connecting the water supply

 Disconnect the coffee machine from the mains power supply before connecting it to the water line. Close the water supply before connecting the coffee machine to the water line.

Make sure that the stopcock remains accessible after the appliance has been installed.

A stopcock with 3/4" thread must be incorporated when connecting the coffee machine to the water supply.

- Check that a sealing ring is present. Fit one if necessary.

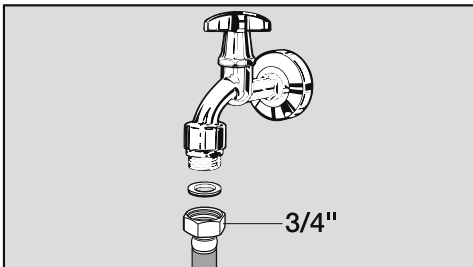

- Connect the stainless steel hose to the stopcock.
- Ensure that it is screwed into position correctly.
- Turn on the water supply stopcock slowly and check for leaks at the mains water connection. Correct the position of the seal and screw thread if appropriate.

Electrical connection

Before connecting the coffee machine, make sure that the connection data on the data plate (voltage and frequency) matches that of the electricity supply. This data must correspond in order to avoid the risk of damage to the coffee machine. If in any doubt, consult a qualified electrician.

The necessary connection data is given on the data plate inside your appliance.

The fuse rating must be at least 10 A.

If possible, the socket should remain easily accessible. If the socket is no longer accessible after installation, an additional means of disconnection must be provided for all poles. Suitable means of disconnection include switches with an all-pole contact gap of at least 3 mm. These include circuit breakers, fuses and contactors (EN 60335).

Do not connect the coffee machine to a **stand-alone inverter**. Stand-alone inverters are used for autonomous power supply, e.g. a solar power system. Power surges could trigger the auto switch off function. This could damage the electronic module.

The coffee machine must not be used with “**energy saving plugs**”. These reduce the amount of energy supplied to the appliance, causing it to overheat.

Installation

Building-in dimensions

Installation in a tall unit

A minimum installation height of 850 mm must be observed.

All dimensions are given in mm.

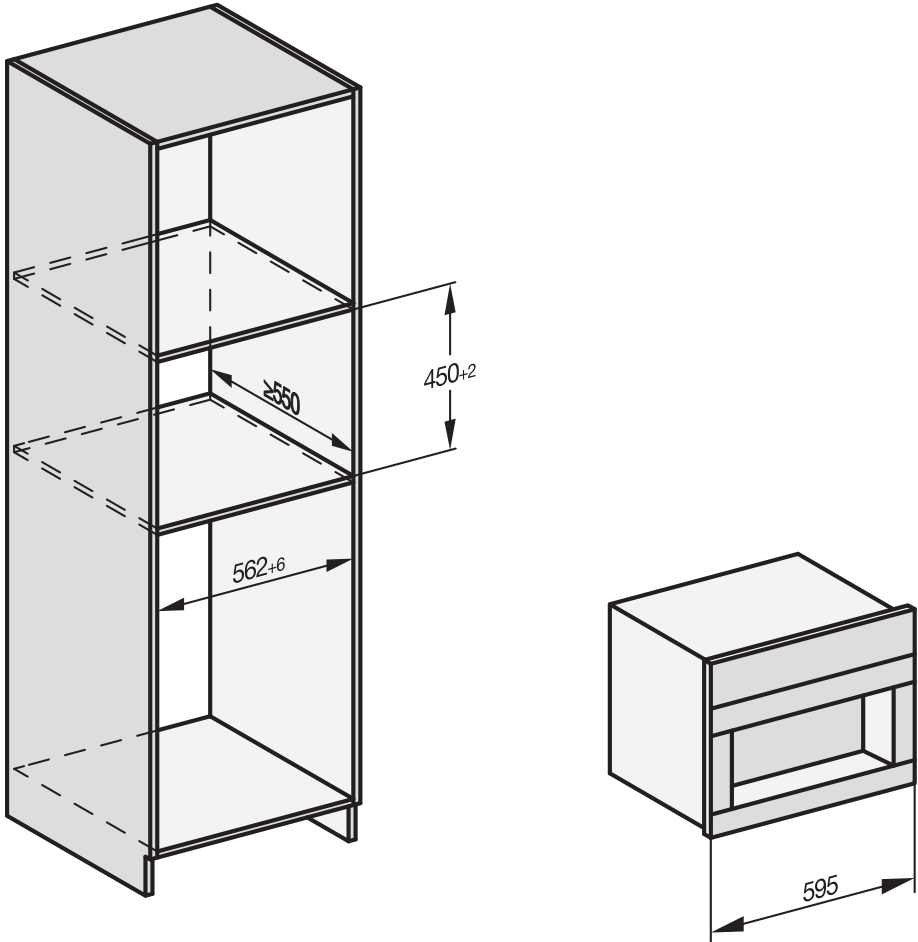

The machine can be combined with other Miele built-in appliances. In this case, there must be a full-width, closed shelf between them. If the machine is to be combined with a suitable built-in crockery/food-warming drawer, no shelf is required in between.

Installation and connections

All dimensions are given in mm.

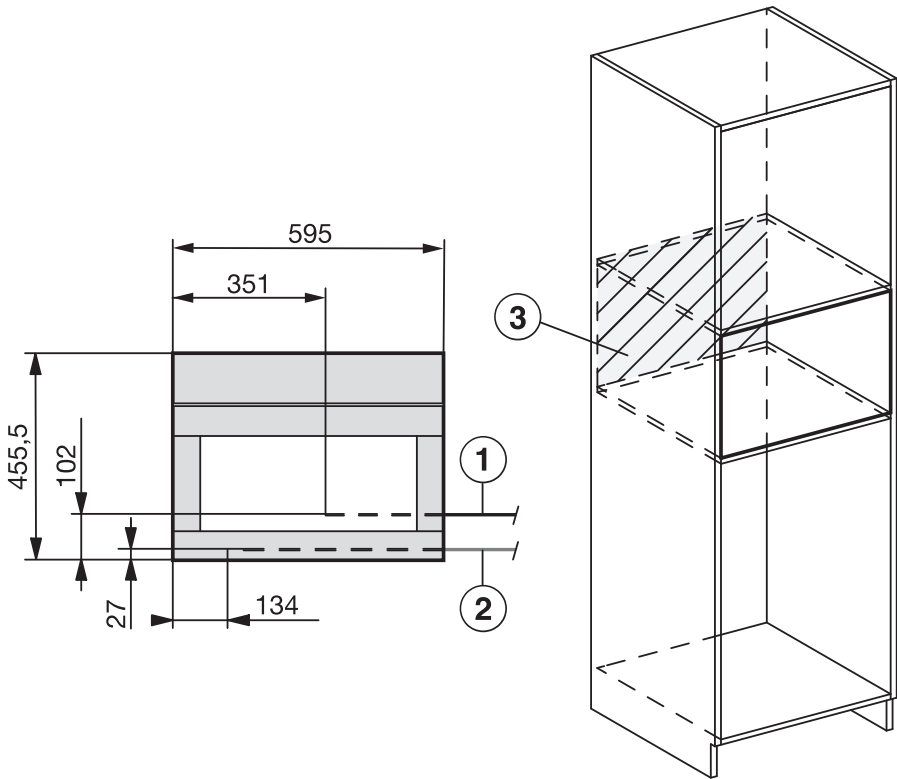

- ① Mains connection cable
- ② Mains water connection
- ③ No electrical or mains water connection in this area

Installation

Building in the coffee machine

 Danger of injury due to incorrect operation.

A machine that has not been built in is not safe and can cause injuries.

Do not operate the coffee machine unless it has been built in.

 Danger of damage due to incorrect operation.

If the ambient temperature range is not observed, the coffee machine may not function properly.

The coffee machine may only be operated within an ambient temperature range of +16 °C to +38 °C.

A minimum installation height of 850 mm must be observed.

A door opening angle of 120° must be ensured so that you can remove the left-hand bean container.

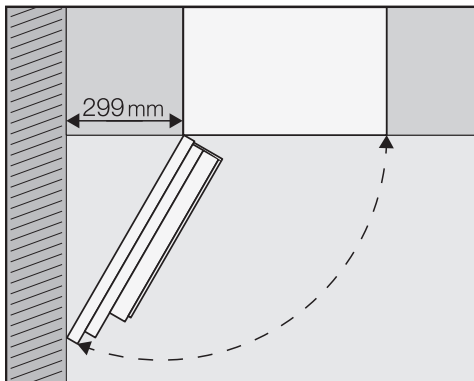

Check that there is a gap of at least 299 mm between the wall (or similar) and the coffee machine so that you can

open the door wide enough to remove the left-hand bean container (minimum door opening angle of 120°).

To install the machine, you will need a TX 20 screwdriver.

Tip: It is useful to have somewhere at the height of the niche to place the machine on. This will make it easier to connect the machine to the electricity and water supplies.

Connecting the water and electricity supplies

Observe the information under “Mains water connection” and “Electrical connection”.

- Connect the coffee machine to the water and electricity supplies.

Pushing in and aligning the coffee machine

When pushing the machine into the niche, make sure that the electrical and mains water connections do not get trapped or damaged.

- Push the coffee machine all the way into the niche until you feel a resistance.
- Check the height of the coffee machine to make sure that it is sitting centrally in the niche and that it is level. Align the machine.

Never align the coffee machine by adjusting the door hinges. This will prevent the milk flask from attaching correctly and interfere with the milk preparation process.

Now screw the coffee machine to the furniture unit.

- Open the machine door.

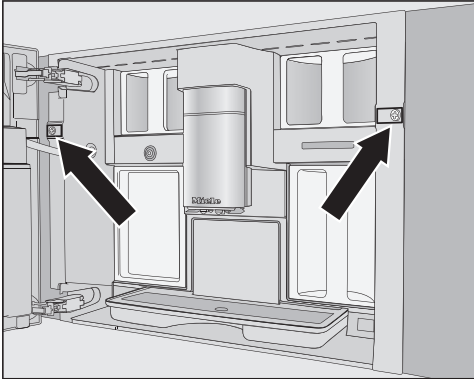

Two TX20 (25 mm) screws are included with the machine.

- Secure the coffee machine to the side walls of the furniture unit using the screws supplied. Tighten both screws by hand.

Tip: To make it easier to attach the screw on the left, you can remove the door opening limiters and increase the door opening angle to approx. 170° (see “Door opening limiters”). Make sure that there is sufficient space available and that the machine door is not going to hit an adjacent wall.

- Carry out a functional check on the coffee machine.

Door opening limiters

The coffee machine door hinges are equipped with door opening limiters that restrict the opening angle of the machine door to approx. 120° . This will prevent the machine door from hitting an adjacent wall and being damaged when opened.

The door opening limiters can be removed, allowing you to increase the opening angle to approx. 170° . This makes it easier to remove the bean containers, for example.

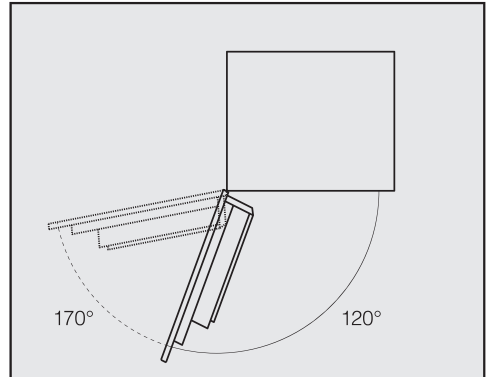

Removing the door opening limiters

Make sure that sufficient space is available for the larger door opening angle and that the machine door is not going to hit an adjacent wall.

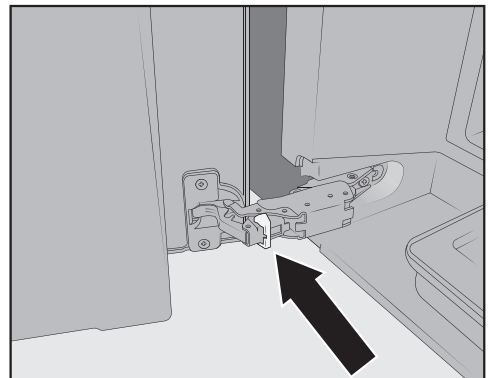

- Remove the door opening limiters from the hinges, e.g. by prising them out with a screwdriver.

The machine door opening angle has now been increased to approx. 170° .

Technical data

Electricity consumption in standby: < 0.6 W

Electricity consumption in networked standby: < 0.9 W

Frequency band of the WiFi module 2.4000 GHz – 2.4835 GHz

Maximum transmitting power of the WiFi module < 100 mW

EU Conformity declaration

Miele hereby declares that this coffee machine complies with Directive 2014/53/EU.

The complete text of the EU declaration of conformity is available from one of the following internet addresses:

- Products, Download from www.miele.ie
- For service, information, operating instructions etc: go to www.miele.ie/domestic/customer-information-385.htm and enter the name of the product or the serial number

UK Conformity declaration

Miele hereby declares that this coffee machine complies with UK Radio Equipment Regulations 2017, as amended.

The complete text of the UK declaration of conformity is available from one of the following internet addresses:

- Products, Download from www.miele.co.uk
- For service, information, operating instructions etc: go to www.miele.co.uk and enter the name of the product or the serial number

United Kingdom

Miele Co. Ltd., Fairacres, Marcham Road, Abingdon, Oxon, OX14 1TW
Tel: 0330 160 6600, Internet: www.miele.co.uk/service, E-mail: info@miele.co.uk

Australia

Miele Australia Pty. Ltd.
ACN 005 635 398
ABN 96 005 635 398
1 Gilbert Park Drive
Knoxfield, VIC 3180
Tel: 1300 464 353
Internet: www.miele.com.au

China Mainland

Miele Electrical Appliances Co., Ltd.
1-3 Floor, No. 82 Shi Men Yi Road
Jing' an District
200040 Shanghai, PRC
Tel: +86 21 6157 3500
Fax: +86 21 6157 3511
E-mail: info@miele.cn
Internet: www.miele.cn

Hong Kong, China

Miele (Hong Kong) Ltd.
41/F - 4101, Manhattan Place
23 Wang Tai Road
Kowloon Bay, Hong Kong
Tel: (852) 2610 1025
Fax: (852) 3579 1404
Email:
customerservices@miele.com.hk
Website: www.miele.hk

India

Miele India Pvt. Ltd.
1st Floor, Copia Corporate Suites,
Commercial Plot 9,
Mathura Road, Jasola,
New Delhi - 110025
E-mail: customercare@miele.in
Website: www.miele.in

Ireland

Miele Ireland Ltd.
2024 Bianconi Avenue
Citywest Business Campus
Dublin 24
Tel: (01) 461 07 10
Fax: (01) 461 07 97
E-Mail: info@miele.ie
Internet: www.miele.ie

Malaysia

Miele Sdn Bhd
Suite 12-2, Level 12
Menara Sapura Kencana
Petroleum
Solaris Dutamas No. 1
Jalan Dutamas 1
50480 Kuala Lumpur, Malaysia
Phone: +603-6209-0288
Fax: +603-6205-3768

New Zealand

Miele New Zealand Limited
IRD 98 463 631
8 College Hill
Freemans Bay, Auckland 1011
New Zealand
Tel: 0800 464 353
Internet: www.miele.co.nz

Singapore

Miele Pte. Ltd.
29 Media Circle
#11-04 ALICE@Mediapolis
Singapore 138565
sTel: +65 6735 1191
Fax: +65 6735 1161
E-Mail: info@miele.com.sg
Internet: www.miele.sg

South Africa

Miele (Pty) Ltd.
63 Peter Place
Bryanston 2194
P.O. Box 69434
Bryanston 2021
Tel: (011) 875 9000
Fax: (011) 875 9035
E-mail: info@miele.co.za
Internet: www.miele.co.za

Thailand

Miele Appliances Ltd.
BHIRAJ TOWER at EmQuartier
43rd Floor Unit 4301-4303
689 Sukhumvit Road
North Klongton Sub-District
Vadhana District
Bangkok 10110, Thailand

United Arab Emirates

Miele Appliances Ltd.
Showroom 1
Eiffel 1 Building
Sheikh Zayed Road, Umm Al Sheif
P.O. Box 114782 - Dubai
Tel. +971 4 3044 999
Fax. +971 4 3418 852
800-MIELE (64353)
E-Mail: info@miele.ae
Website: www.miele.ae

Manufacturer: Miele & Cie. KG, Carl-Miele-Straße 29, 33332 Gütersloh, Germany

CVA 7445

en-GB

M.-Nr. 11 860 131 / 00